

ELECTROPNEUMATIC PRESSURE REGULATORS



aerospace
climate control
electromechanical
filtration
fluid & gas handling
hydraulics
pneumatics
process control
sealing & shielding



Basic	1/4" 1/2"
Comfort	1/4" 1/2"
Comfort	1/2" HP 1" 2"
Comfort ATEX	1/2" 1" 2"

ELECTROPNEUMATIC PRESSURE REGULATORS

Lucifer® EPP4 Programmable Pressure Regulator

EPP4 is an electro pneumatic pressure regulator with integrated electronic system.

A pulsed width modulated solenoid valve controls the output pressure proportionally to an analog input signal.

Very high accuracy is guaranteed thanks to a high precision closed loop signal provided by a built in pressure sensor.



Market

- Robotics
- Paper industry
- Machine tools
- Mobile
- Buildings
- Textile
- Instrumentation
- Semi conductor



Description of Applications

- Welding
- Speed and brake control
- Sanding
- Cutting
- Humidification
- Tension regulation
- Painting
- Presses
- Polishing
- Adaptative suspension control



Value Propositions for the Lucifer® EPP4 Range of Proportional Pressure Regulators

- All parameters fully adjustable through the PC software Calys
- Easy to use software
- Long life expectancy
- Compact and light
- Limited inventory
- Low power
- Flexible remote display positioning
- Proven expertise of Parker, a pioneer in pressure regulation technology



calys Software for EPP Comfort

Calys is a unique software in house developed to configurate all the parameters of the EPP4 Comfort range.

Calys is an option of the EPP4. To use CALYS, you need to order cable reference 496449 wich permits the communication between the EPP4 and a PC.

Calys offers many capabilities:

- It enables distributors to reduce inventory by keeping a generic EPP4 in stock and adjust it to the needs of each customer application. They can switch for example from 0-10 V to 4-20 mA, or from 0-7 bar pressure range to 0-5 bar.
- Engineers designing a pneumatic system are able to monitor precisely all the important values (electrical or pneumatical) directly on their laptop.
- After sales technicians are able to receive via email all the parameters measured by the EPP4 installed on a machine wherever its location allowing remote ma intenance operation.
- PID regulation parameters can be adjusted with Calys to match required regulator response (like slow or reactive).



To download free Calys software click on www.parker.com/FCDE/Support

ELECTROPNEUMATIC PRESSURE REGULATORS



TABLE OF CONTENT

Introduction EPPpage 412

EPP4 Basic Rangepage 414

EPP4 Comfort Rangepage 418

EPP4 Comfort HP Rangepage 422

EPP4 Comfort Range ATEXpage 428

Accessoriespage 434



INTRODUCTION

Description Operation

The EPP4 Series is a family of electrically remote-controlled pneumatic pressure regulators with closed loop integrated electronic control.

It allows regulating the outlet pressure proportionally to an electrical control signal.

The EPP4 regulator comprises a traditional servo-operated pneumatic pressure regulator, where the pilot chamber is fed by one or the other of two pulse width modulated 2-way solenoid valves.

The pressure sensor measures the outlet pressure of the regulator and provides a feedback signal to the controller.

Any difference between the control signal and the feedback signal is converted to a digital signal to energise the coil of one or the other 2-way valves to correct the position of the regulator.

The control signal can be a voltage (0-10 V) or a current (4-20 mA). The inlet of the "Filling Valve" is connected directly to the main inlet P of the

regulator; when energised this valve will fill the servo-chamber for increasing the pressure at the outlet A of the regulator.

When the other "exhaust valve" is energised (reduction of pressure at the outlet A of the regulator), the pressure of the servo-chamber will be exhausted through a discharge orifice located between the cover and the body and directly fed to the atmosphere without silencer.

The exhaust of the main regulated pressure will be made through the quick exhaust R.

The use of a conventional silencer is recommended. Both solenoid valves assure the Filling or Emptying of the servo-chamber in order to increase or decrease the pressure at the outlet of the regulator.

In rest position of the valves all ports are blocked.

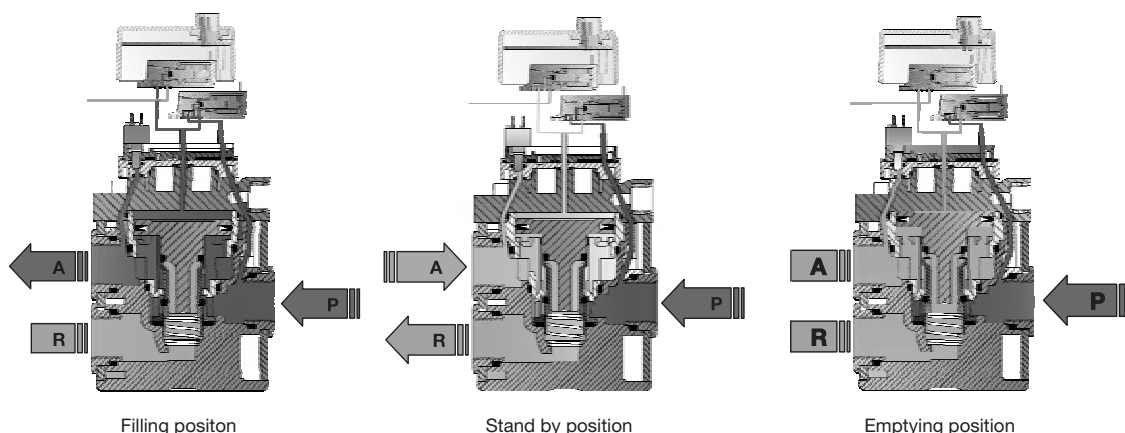

Block Diagram

The controller receives both the control signal (set pressure) and the feedback signal from the sensor (outlet pressure).

Any difference between the two amplifier inputs results in a corresponding output which drives the appropriate 2-way pulse width modulated solenoid valve so that the pilot piston moves to correct the pressure.

The same feedback signal from the sensor is used for the output feedback in voltage and current.

The digital signal (alarm) is activated when the conditions (out of pressure or time tolerance) are met.

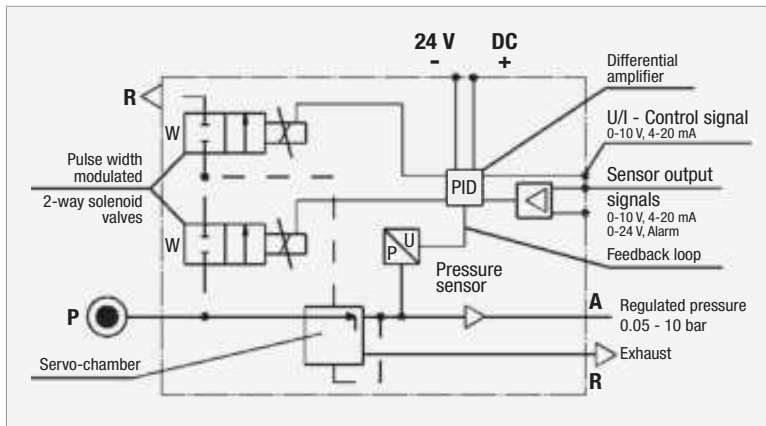

EPP4 possible executions : Basic and Comfort

EPP4 Basic and Comfort ranges share the same reliable mechanical parts. Proportional regulation is also identical for the two different executions, giving the same characteristics for hysteresis or precision for instance.

Comfort range regulators have a second M12 connector, that can be used to connect a remote display showing the current regulated pressure, or a PC to easily set the regulation's parameters. These are the key feature options for a comfortable use.

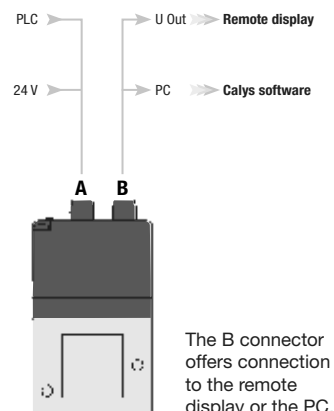

LUCIFER® EPP4 BASIC 1/4" & 1/2"

Basic	1/4" 1/2"
Comfort	1/4" 1/2"
Comfort	1/2" HP 1" 2"
Comfort ATEX	1/2" 1" 2"

TECHNICAL DATA

	Basic 1/4"	Basic 1/2"
Fluids:	Lubricated or non lubricated air and neutral gases Recommended filtration: 50 µm	
Temperature range:	Ambient: 0°C to +50°C Fluid: 0°C to +50°C	
Inlet pressure range: The inlet pressure must always be at least 1 bar above the regulated pressure.	1 to 12 bar	1 to 12 bar
Outlet pressure range:	0.05 to 10 bar	
Hysteresis:	± 50 mbar (factory set up)	
Air consumption at constant control signal:	0	
Supply voltage:	24 V DC ± 15% (Max. ripple 1 V)	
Power consumption:	Max. 2.8 W with 24 V DC and constant changes of the control signal < 1.5 W without change of control signal	
Control signal:	Analog 0 - 10 V Analog 4 - 20 mA	
Max. flow: Indicative response time: With a volume of 330 cm ³ at the outlet of the regulator	70 m ³ /h	150 m ³ /h
Filling 2 to 4 bar:	50 msec	60 msec
Filling 2 to 8 bar:	100 msec	120 msec
Emptying 4 to 2 bar:	70 msec	90 msec
Emptying 8 to 2 bar:	130 msec	190 msec
Safety position:	In case of control signal failure or if it is less than 50mV, the regulated pressure drops automatically to 0 bar (atmospheric pressure). In case of voltage supply failure, the regulated pressure will be kept constant.	
Electrical connection:	M12 - 4 pin; 4 x 0.34 mm ²	
Life expectancy:	> 50 Million changes of control signal steps	
Mounting position:	Indifferent (recommended position: upright; electronic part on top)	
Resistance to vibrations:	30 g in all directions	
Degree of protection:	IP 65	
Assembly:	Silicone free	
Electromagnetic compatibility: In accordance with:	EN 61000-6-1: 2001 EN 61000-6-2: 2001 EN 61000-6-3: 2001 EN 61000-6-4: 2001	
Installation and setting instructions:	See our "Notice 408038, 408014" and appendix supplied with the product.	

Note: Parker reserves the right to change specifications without notification.

LUCIFER® EPP4 BASIC 1/4" & 1/2"

FLOW CURVES

Flow Curve Basic 1/4"

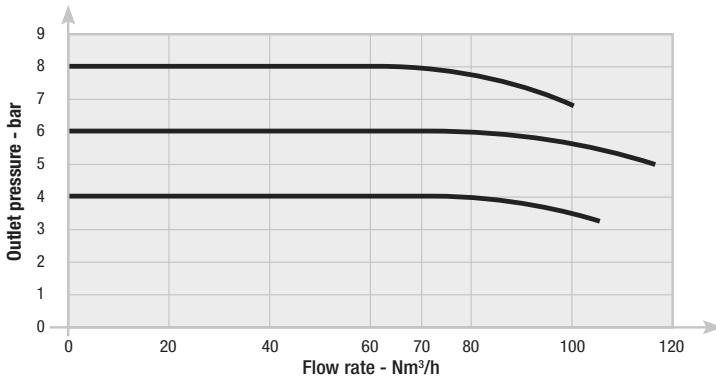

Flow Curve Basic 1/2"

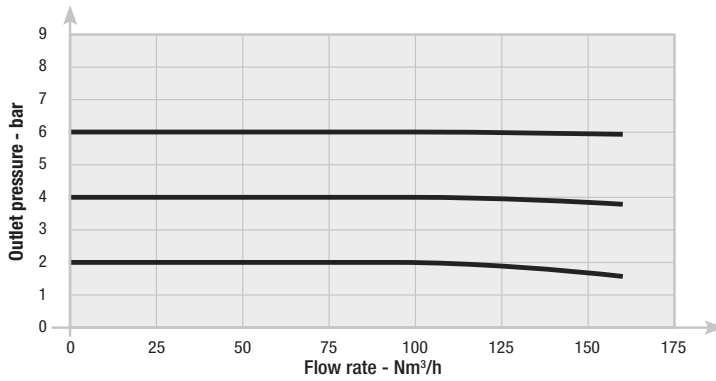

LUCIFER® EPP4 BASIC 1/4" & 1/2"

REFERENCES

Codes	Pipe	Pressure Range (bar)		Control Signal (see options)	Drawing Number
P4BG2001A001	G 1/4"	0	4 bar	4 - 20 mA	1
P4BG2001A002	G 1/4"	0	10 bar	0 - 10 V	1
P4BG2001A003	G 1/4"	0	10 bar	4 - 20 mA	1
P4BG2001A004	G 1/4"	0	6 bar	0 - 10 V	1
P4BG2001A005	G 1/4"	0	6 bar	4 - 20 mA	1
P4BG2001A006	G 1/4"	0	5 bar	0 - 10 V	1
P4BG2001A007	G 1/4"	0	5 bar	4 - 20 mA	1
P4BG2001A008	G 1/4"	0	7 bar	0 - 10 V	1
P4BG2001A009	G 1/4"	0	7 bar	4 - 20 mA	1
P4BG2003A002 *	G 1/4"	0	10 bar	0 - 10 V	1
P4BG2003A003 *	G 1/4"	0	10 bar	4 - 20 mA	1
P4BG4001A002	G 1/2"	0	10 bar	0 - 10 V	2
P4BG4001A003	G 1/2"	0	10 bar	4 - 20 mA	2
P4BG4001A004	G 1/2"	0	6 bar	0 - 10 V	2
P4BG4001A005	G 1/2"	0	6 bar	4 - 20 mA	2
P4BG4001A006	G 1/2"	0	5 bar	0 - 10 V	2
P4BG4001A007	G 1/2"	0	5 bar	4 - 20 mA	2
P4BG4001A008	G 1/2"	0	7 bar	0 - 10 V	2
P4BG4001A009	G 1/2"	0	7 bar	4 - 20 mA	2
P4BG4004A010 ***	G 1/2"	0	4 bar	0 - 10 V	2
P4BG4051A002 **	G 1/2"	0	10 bar	4 - 20 mA	2
P4BN2001A002	NPT 1/4"	0	10 bar	0 - 10 V	2
P4BN2001A003	NPT 1/4"	0	10 bar	4 - 20 mA	2
P4BN4001A002	NPT 1/2"	0	10 bar	0 - 10 V	2
P4BN4001A003	NPT 1/2"	0	10 bar	4 - 20 mA	2

* Integrated pilot exhaust

** O2

*** External pressure supply



LUCIFER® EPP4 BASIC 1/4" & 1/2"

DIMENSIONS DRAWINGS EPP4 BASIC 1/4"

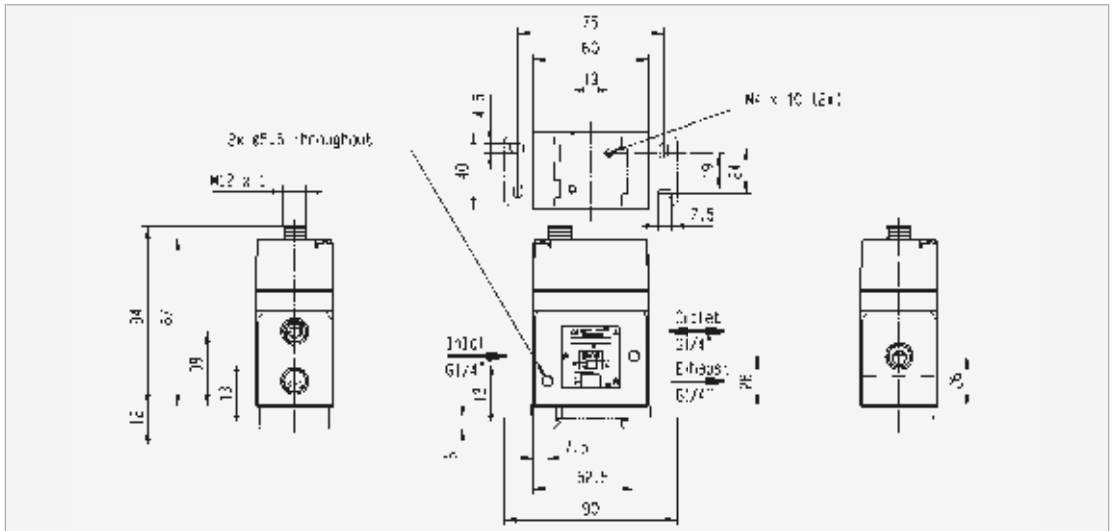

Drawing 1

DIMENSIONS DRAWINGS EPP4 BASIC 1/2"

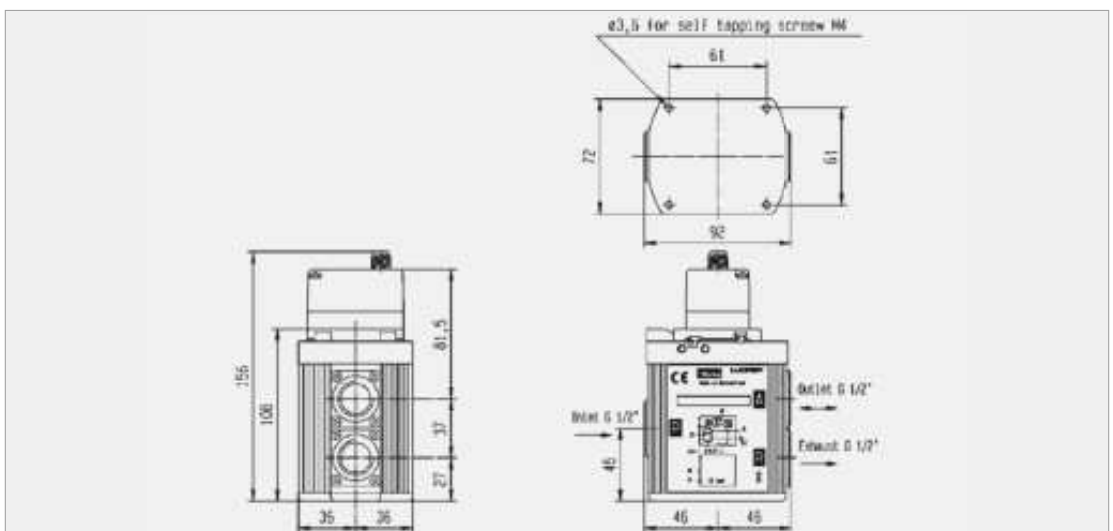

Drawing 2

LUCIFER® EPP4 COMFORT 1/4" & 1/2"

TECHNICAL DATA

Basic	1/4" 1/2"
Comfort	1/4" 1/2"
Comfort	1/2" HP 1" 2"
Comfort ATEX	1/2" 1" 2"

	Comfort 1/4"	Comfort 1/2"
Fluids:	Lubricated or non lubricated air and neutral gases - Recommended fil tration: 50 µm	
Temperature range:	Ambient: 0°C to +50 °C Fluid: 0°C to +50 °C	
Inlet pressure range: The inlet pressure must always be at least 1 bar above the regulated pressure.	1 to 12 bar	1 to 12 bar
Outlet pressure range:	0.05 bis 10 bar	
Hysteresis:	± 50 mbar (factory set up)	
Air consumption at constant control signal:	0	
Supply voltage:	24 V DC ± 15 % (Max. ripple 1 V)	
Power consumption:	Max. 2.8 W with 24 V DC and constant changes of the control signal < 1.5 W without change of control signal	
Control signal:	Analog 0 - 10 V Analog 4 - 20 mA	
Outlet sensor signal:	Analog 0 - 10 V Standard for 0 - 10 bar; Adjustable Analog 4 - 20 mA Standard for 0 - 10 bar; Adjustable	Digital 0/24 V for alarm features: Adjustable pressure error (+/-) Adjustable delay ON Adjustable delay OFF Adjustable logic (+/-)
Max. flow:	70 m³/h	150 m³/h
Indicative response time:	With a volume of 330 cm³ at the outlet of the regulator	
Filling 2 to 4 bar :	50 msec	60 msec
Filling 2 to 8 bar:	100 msec	120 msec
Emptying 4 to 2 bar:	70 msec	90 msec
Emptying 8 to 2 bar:	130 msec	190 msec
Safety position:	In case of control signal failure or if it is less than 50 mV, the regulated pressure drops automatically to 0 bar (atmospheric pressure). In case of voltage supply failure, the regulated pressure will be kept constant.	
Electrical connection:	M12 - 8 pin; male connector power supply/control signal M12 - 5 pin; male connector communication	
Life expectancy:	> 50 Million changes of control signal steps	
Mounting position:	Indifferent (recommended position: upright; electronic part on top)	
Resistance to vibrations:	30 g in all directions	
Degree of protection:	IP 65	
Assembly:	Silicone free	
Electromagnetic compatibility: In accordance with:	EN 61000-6-1: 2001 EN 61000-6-2: 2001 EN 61000-6-3: 2001 + A11 2004 edition (01/07/07) EN 61000-6-4: 2001	
Installation and setting instructions:	See our "Notice 408128, 408134" and appendix supplied with the product.	

Note: Parker reserves the right to change specifications without notification.

LUCIFER® EPP4 COMFORT 1/4" & 1/2"

Flow Curves

Flow Curve 1/4"

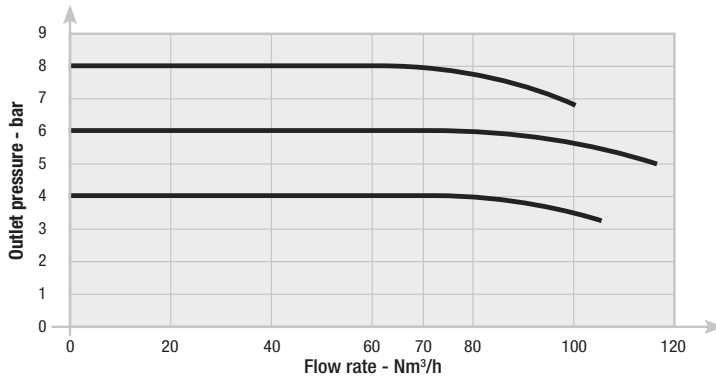

Flow Curve 1/2"

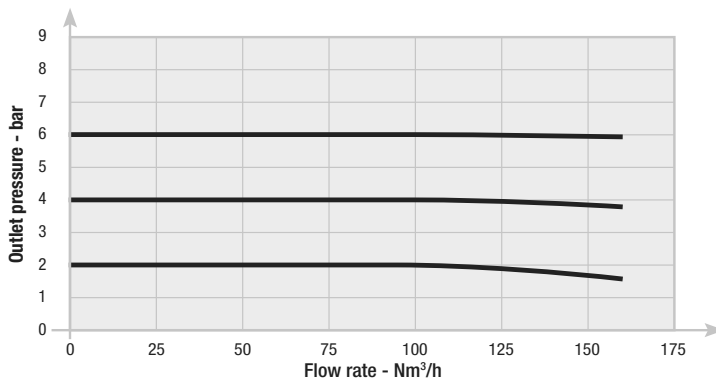

LUCIFER® EPP4 COMFORT 1/4" & 1/2"

REFERENCES

Codes	Pipe	Pressure Range (bar)		Control Signal (see options)	Display	Drawing Number
P4CG2001C001	G 1/4	0	10	0-10 V	-	3
P4CG2001C002	G 1/4	0	10	4-20 mA	-	3
P4CG2001C005	G 1/4	0	7	0-10 V	-	3
P4CG2001C006	G 1/4	0	7	4-20 mA	-	3
P4CG2002C001	G 1/4	0	10	0-10 V	included	3
P4CG2002C002	G 1/4	0	10	4-20 mA	included	3
P4CG2003C001 *	G 1/4	0	10	0-10 V	-	3
P4CG2003C002 *	G 1/4	0	10	4-20 mA	-	3
P4CG2002C007	G 1/4	0	7	0-10 V	-	3
P4CG2002C008	G 1/4	0	7	4-20 mA	-	3
P4CN2001C001	1/4 NPT	0	10	0-10 V	-	3
P4CN2001C002	1/4 NPT	0	10	4-20 mA	-	3
P4CN2002C001	1/4 NPT	0	10	0-10 V	included	3
P4CN2002C002	1/4 NPT	0	10	4-20 mA	included	3
P4CG4001C001	G 1/2	0	10	0-10 V	-	4
P4CG4001C002	G 1/2	0	10	4-20 mA	-	4
P4CG4001C005	G 1/2	0	7	0-10 V	-	4
P4CG4001C006	G 1/2	0	7	4-20 mA	-	4
P4CG4002C001	G 1/2	0	10	0-10 V	included	4
P4CG4002C002	G 1/2	0	10	4-20 mA	included	4
P4CG4002C005	G 1/2	0	7	0-10 V	-	4
P4CG4002C006	G 1/2	0	7	4-20 mA	-	4
P4CG4051C001 **	G 1/2	0	10	0-10 V	-	4
P4CG4051C002 **	G 1/2	0	10	4-20 mA	-	4
P4CN4001C001	1/2 NPT	0	10	0-10 V	-	4
P4CN4001C002	1/2 NPT	0	10	4-20 mA	-	4
P4CN4002C001	1/2 NPT	0	10	0-10 V	included	4
P4CN4002C002	1/2 NPT	0	10	4-20 mA	included	4

* Integrated pilot exhaust

** O2



LUCIFER® EPP4 COMFORT 1/4" & 1/2"

DIMENSIONS DRAWINGS EPP4 COMFORT RANGE 1/4"

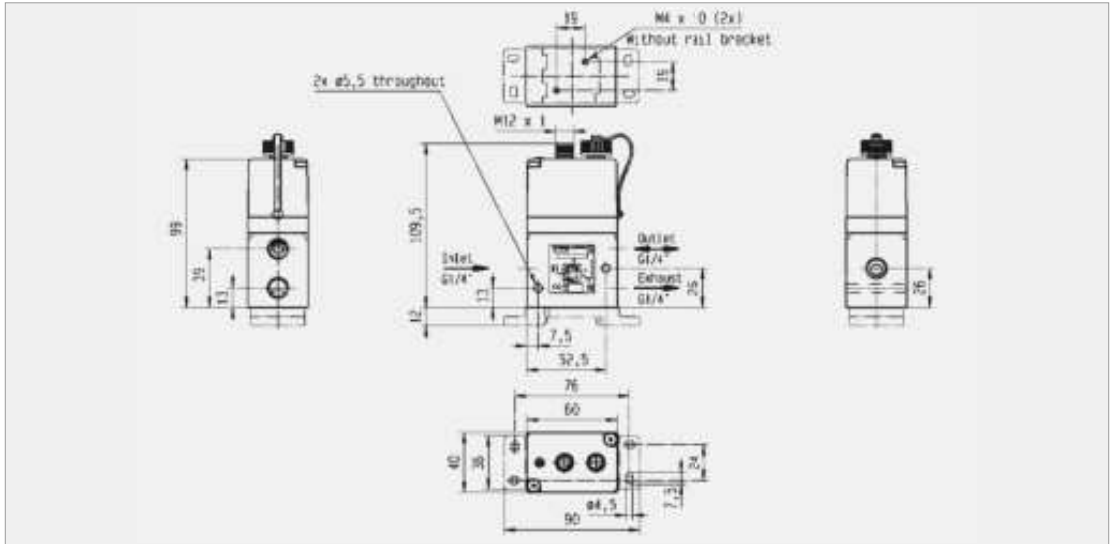

Drawing 3

DIMENSIONS DRAWINGS EPP4 COMFORT RANGE 1/2"

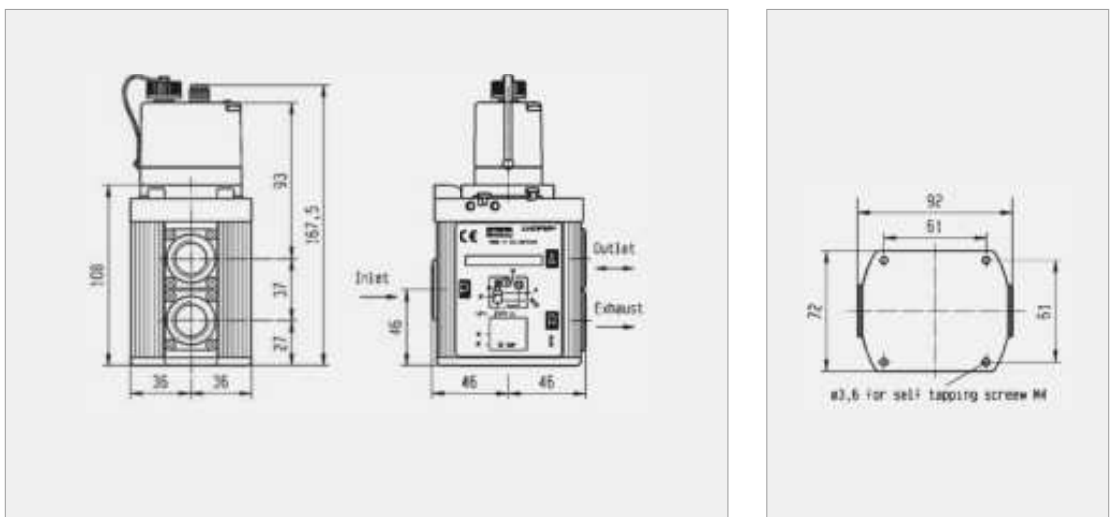

Drawing 4

LUCIFER® EPP4 COMFORT 1/2"HP, 1" & 2"

Basic	1/4" 1/2"
Comfort	1/4" 1/2"
Comfort	1/2" HP 1" 2"
Comfort ATEX	1/2" 1" 2"

TECHNICAL DATA

	Comfort 1/2" HP	Comfort 1"	Comfort 2"
Fluids:	Lubricated or non lubricated air and neutral gases - Recommended fi ltration: 50 µm		
Temperature range:	Ambient: 0°C to +50°C Fluid: 0°C to +50°C		
Inlet pressure range: The inlet pressure must always be at least 1 bar above the regulated pressure.	1 to 21 bar	1 to 21 bar	1 to 12 bar
Outlet pressure range:	0.05 to 20 bar	0.05 to 20 bar	0.05 to 10 bar
Hysteresis:	≤ 100 mbar if P inlet ≤ 10 bar ≤ 200 mbar if P inlet > 10 bar		
Air consumption at constant control signal:	0		
Supply voltage:	24V DC ± 15%		
Power consumption:	Max. 6 W with 24 V DC and constant changes of the control signal < 2 W without change of control signal		
Control signal:	Analog 0 - 10 V Analog 4 - 20 mA		
Outlet sensor signal:	Analog 0 - 10 V Standard for 0 - 10 bar; Adjustable	Digital 0/24 V for alarm features: Adjustable pressure error (+/-) Adjustable delay ON Adjustable delay OFF Adjustable logic (+/-)	
	Analog 4 - 20 mA Standard for 0 - 10 bar; Adjustable		
Max. flow:	150 m³/h	1 000 m³/h	2 700 m³/h
Indicative response time:	With a volume of 330 cm³ at the outlet of the regulator		
Filling 2 to 8 bar:	120 msec	250 msec	250 msec
Emptying 8 to 2 bar:	190 msec	400 msec	400 msec
Safety position:	In case of control signal failure or if it is less than 50 mV, the regulated pressure drops automatically to 0 bar atmospheric pressure (for pressure ranges from 0-10 bar, 100 mV for pressure range over 10 bar). In case of voltage supply failure, the regulated pressure will be kept constant.		
Electrical connection:	M12 - 8 pin; male connector power supply/control signal M12 - 5 pin; male connector communication		
Life expectancy:	> 20 Million changes of control signal steps		
Mounting position:	Indifferent (recommended position: upright; electronic part on top)		
Resistance to vibrations:	30 g in all directions		
Degree of protection:	IP 65		
Assembly:	Silicone free		
Electromagnetic compatibility: In accordance with:	EN 61000-6-1: 2001 EN 61000-6-2: 2001 EN 61000-6-3: 2001 + A11 2004 edition (01/07/07) EN 61000-6-4: 2001		
Installation and setting instructions:	See our "408 193" and appendix supplied with the product.		

Note: Parker reserves the right to change specifications without notification.

LUCIFER® EPP4 COMFORT 1/2"HP, 1" & 2"

FLOW CURVES



Flow Curve 1/2"HP

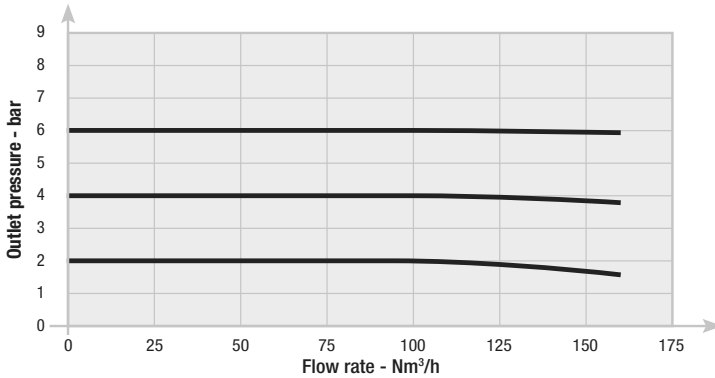

Flow Curve 1"

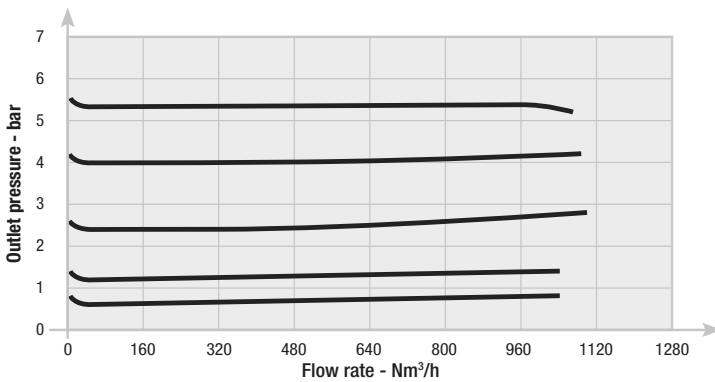

Flow Curve 2"

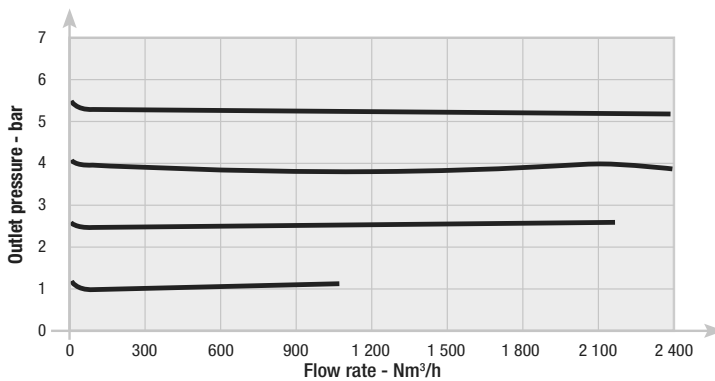

LUCIFER® EPP4 COMFORT 1/2"HP

REFERENCES

Codes	Pipe	Max inlet pressure (bar)	Pressure range (bar)		Control signal (see options)	Dimensional Drawing
P4CG4101D001	G1/2	15	0	12	0-10 V	5
P4CG4201D005	G1/2	21	0	16	0-10 V	6
P4CG4201D003	G1/2	21	0	20	0-10 V	6
P4CG4201D004	G1/2	21	0	20	4-20 mA	6

Other specific settings or specialties are available, please contact us.



LUCIFER® EPP4 COMFORT 1/2"HP

DIMENSIONS DRAWINGS

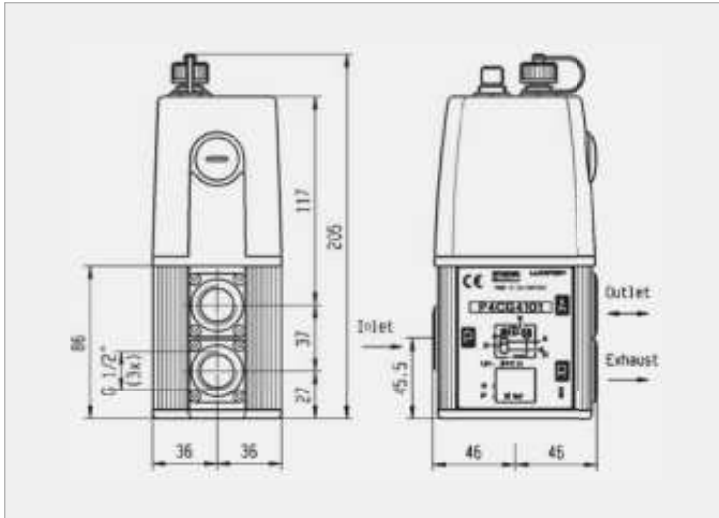
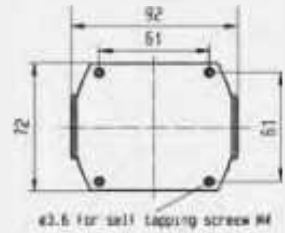

Drawing 5

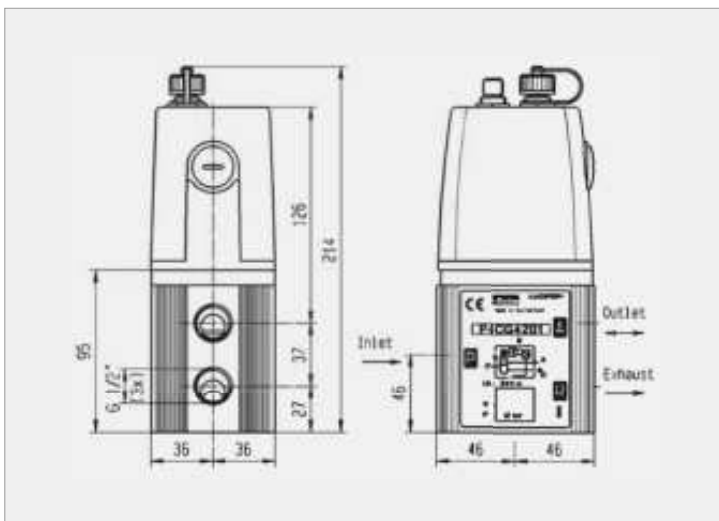
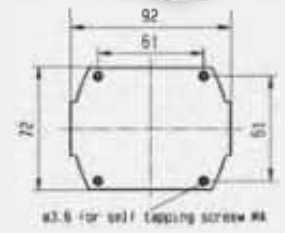

Drawing 6

LUCIFER® EPP4 COMFORT 1" & 2"

REFERENCES

Codes	Pipe	Max inlet pressure (bar)	Pressure range (bar)		Control signal (see options)	Dimensional Drawing
P4CG6101C009	G1	12	0	3.5	4-20 mA	7
P4CG6101C011	G1	12	0	5.0	0-10 V	7
P4CG6101C010	G1	12	0	6.0	4-20 mA	7
P4CG6101C001	G1	12	0	10	0-10 V	7
P4CG6101C002	G1	12	0	10	4-20 mA	7
P4CG6201D001	G1	21	0	12	0-10 V	7
P4CG6201D003	G1	21	0	20	0-10 V	7
P4CG9101C012	G2	12	0	4.0	4-20 mA	8
P4CG9101C010	G2	12	0	6.0	4-20 mA	8
P4CG9101C001	G2	12	0	10	0-10 V	8
P4CG9101C002	G2	12	0	10	4-20 mA	8

Other specific settings or specialties are available, please contact us.

LUCIFER® EPP4 COMFORT 1" & 2"

DIMENSIONS DRAWINGS EPP4 COMFORT RANGE 1"

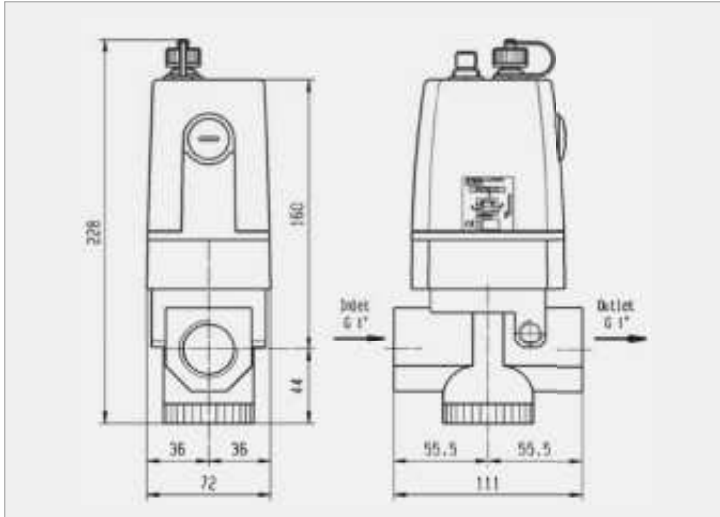

Drawing 7

DIMENSIONS DRAWINGS EPP4 COMFORT RANGE 2"

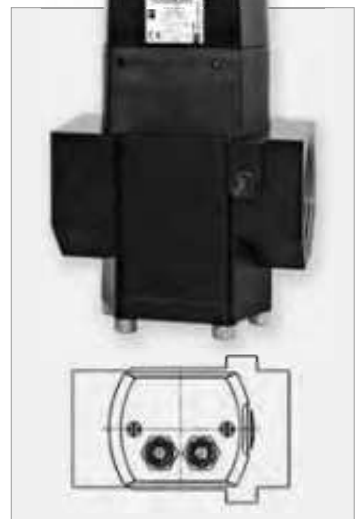
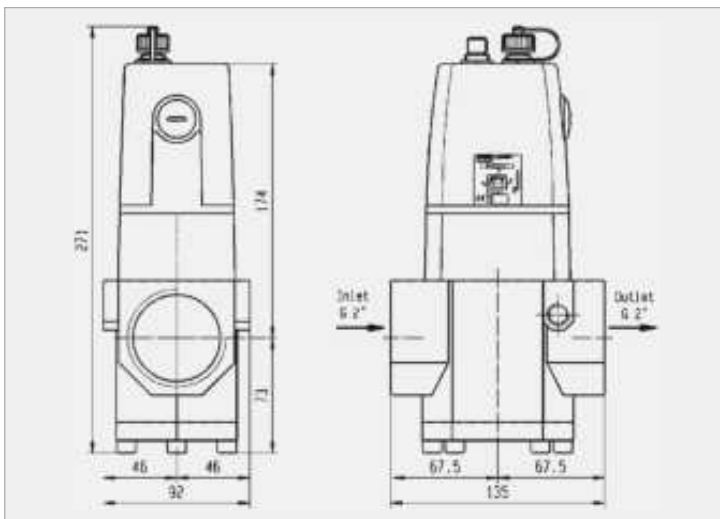

Drawing 8

LUCIFER® EPP4 COMFORT 1/2", 1" & 2" ATEX



Basic	1/4" 1/2"
Comfort	1/4" 1/2"
Comfort	1/2" HP 1" 2"
Comfort ATEX	1/2" 1" 2"

TECHNICAL DATA

	Comfort 1/2" ATEX	Comfort 1" ATEX	Comfort 2" ATEX
Fluids:	Lubricated or non lubricated air and neutral gases - Recommended filtration: 50 µm		
Temperature range:	Ambient: 0°C to +50°C Fluid: 0°C to +50°C		
Inlet pressure range: The inlet pressure must always be at least 1 bar above the regulated pressure.	Inlet pressure range: 1 to 12 bar		
Outlet pressure range:	Outlet pressure range: 0.05 to 10 bar		
Hysteresis:	≤ 100 mbar		
Air consumption at constant control signal:	0		
ATEX certification:	Ex II 3 G/D Ex nA IIC T4 Gc Ex tc IIIB T130°C Dc		
Supply voltage:	24V DC ± 15 %		
Power consumption:	Max. 6 W with 24 V DC and constant changes of the control signal < 2 W without change of control signal		
Control signal:	Analog 0 - 10 V Analog 4 - 20 mA		
Outlet sensor signal:	Analog 0 - 10 V Standard for 0 - 10 bar; Adjustable	Digital 0/24 V for alarm features: Adjustable pressure error (+/-) Adjustable delay ON Adjustable delay OFF Adjustable logic (+/-)	
	Analog 4 - 20 mA Standard for 0 - 10 bar; Adjustable		
Max. flow:	150 m³/h	1 000 m³/h	2 700 m³/h
Indicative response time:	With a volume of 330 cm³ at the outlet of the regulator		
Filling 2 to 8 bar:	120 msec	250 msec	250 msec
Emptying 8 to 2 bar:	190 msec	400 msec	400 msec
Safety position:	In case of control signal failure or if it is less than 50 mV, the regulated pressure drops automatically to 0 bar atmospheric pressure (for pressure ranges from 0-10 bar, 100 mV for pressure range over 10 bar). In case of voltage supply failure, the regulated pressure will be kept constant.		
Electrical connection:	M12 - 8 pin; male connector power supply/control signal M12 - 5 pin; male connector communication		
Life expectancy:	> 20 Million changes of control signal steps		
Mounting position:	Indifferent (recommended position: upright; electronic part on top)		
Resistance to vibrations:	30 g in all directions		
Degree of protection:	IP 54		
Assembly:	Silicone free		
Electromagnetic compatibility: In accordance with:	EN 61000-6-1: 2001 EN 61000-6-2: 2001 EN 61000-6-3: 2001 + A11 2004 edition (01/07/07) EN 61000-6-4: 2001		
Installation and setting instructions:	See our "408 283" and appendix supplied with the product.		

Note: Parker reserves the right to change specifications without notification.

LUCIFER® EPP4 COMFORT 1/2", 1" & 2" ATEX



FLOW CURVES

Flow Curve 1/2"

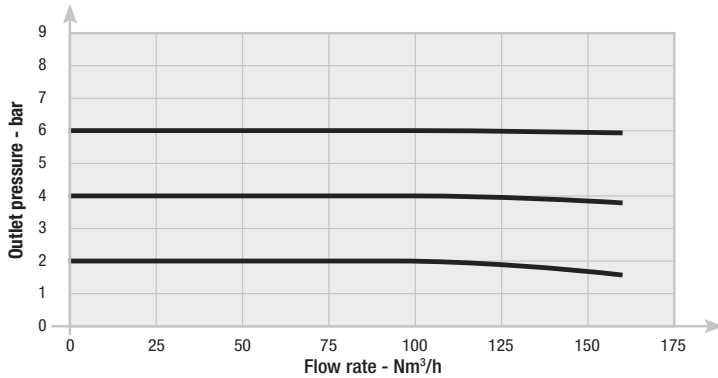

Flow Curve 1"

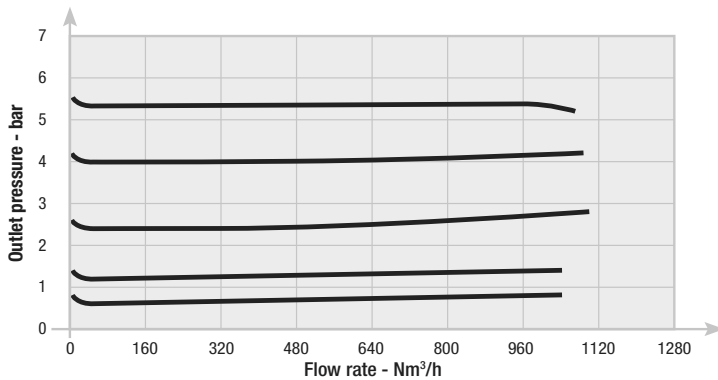

Flow Curve 2"

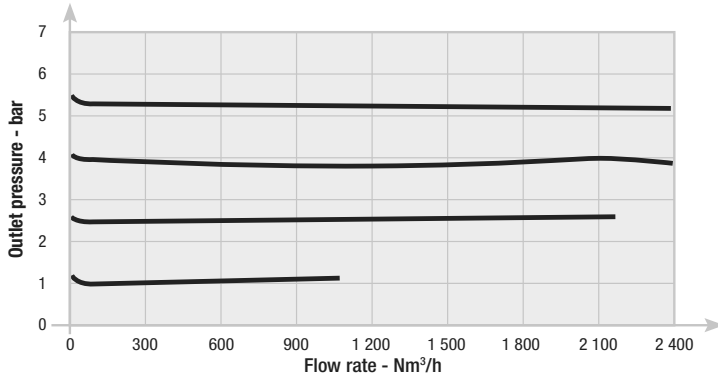

LUCIFER® EPP4 COMFORT 1/2" ATEX



REFERENCES

Codes	Pipe	Max inlet pressure (bar)	Pressure range (bar)		Control signal (see options)	Dimensional Drawing
P4CG4461C001	G1/2	12	0	10	0-10 V	9
P4CG4461C002	G1/2	12	0	10	4-20 mA	9
P4CG4465C001 **	G1/2	12	0	10	0-10 V	9
P4CG4465C002 **	G1/2	12	0	10	4-20 mA	9

** O2

Other specific settings or specialties are available, please contact us.



LUCIFER® EPP4 COMFORT 1/2" ATEX



DIMENSIONS DRAWINGS

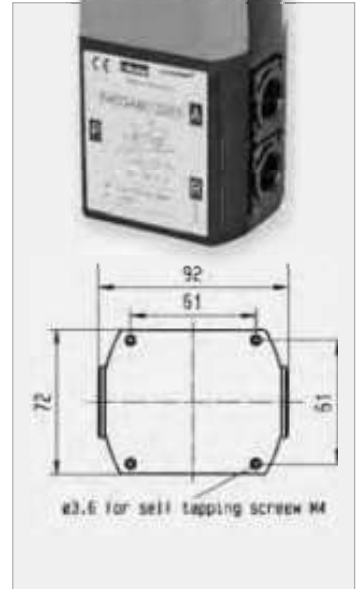
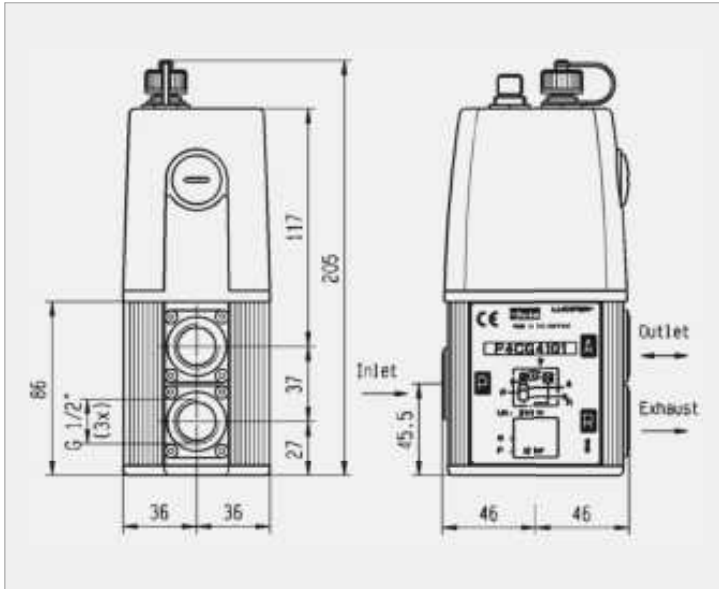

Drawing 9

LUCIFER® EPP4 COMFORT 1" & 2" ATEX



REFERENCES

Codes	Pipe	Max inlet pressure (bar)	Pressure range (bar)		Control signal (see options)	Dimensional Drawing
P4CG6161C001	G1	12	0	10	0-10 V	11
P4CG6161C002	G1	12	0	10	4-20 mA	11
P4CG9161C001	G2	12	0	10	0-10 V	12
P4CG9161C002	G2	12	0	10	4-20 mA	12

Other specific settings or specialties are available, please contact us.

LUCIFER® EPP4 COMFORT 1" & 2" ATEX



DIMENSIONS DRAWINGS EPP4 COMFORT RANGE 1"

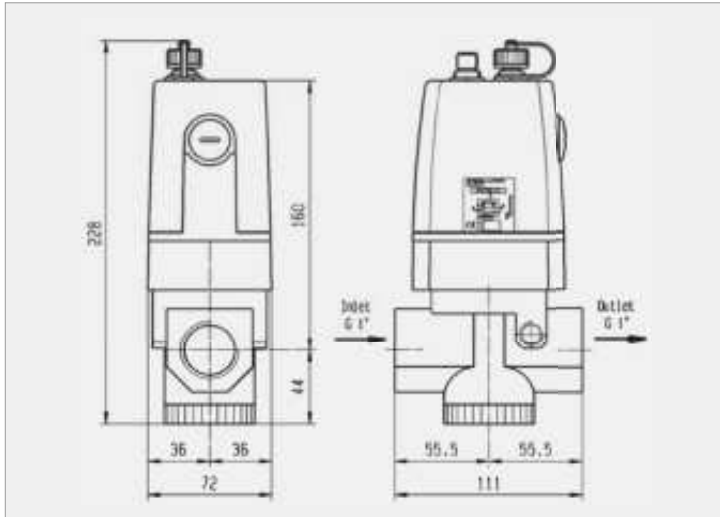

Drawing 11

DIMENSIONS DRAWINGS EPP4 COMFORT RANGE 2"

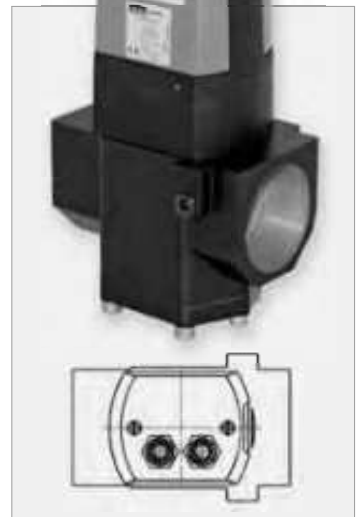
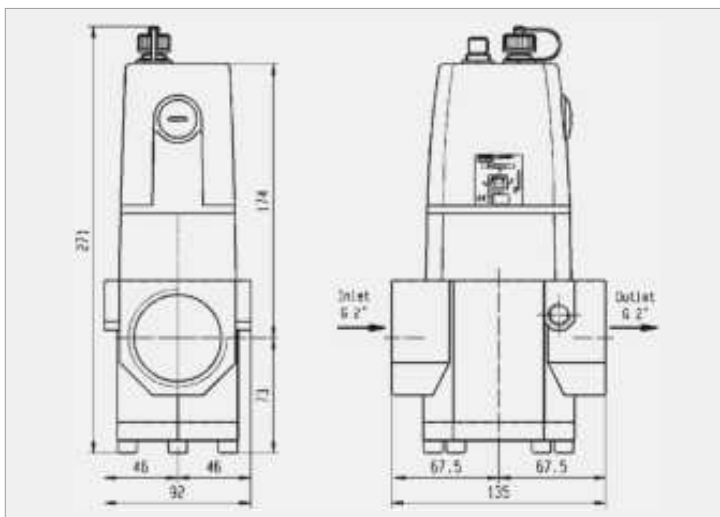

Drawing 12

LUCIFER® EPP4 ACCESSORIES

MOUNTING BRACKETS FOR EPP4 1/4" BASIC / COMFORT



This mounting bracket is delivered as a standard with all EPP4 1/4".

LUCIFER® EPP4 ACCESSORIES

MOUNTING BRACKETS FOR EPP4 1/2" BASIC / COMFORT

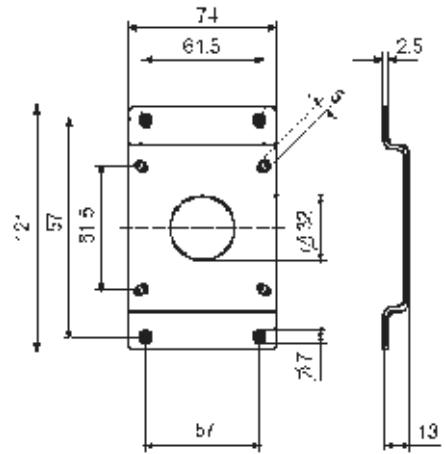
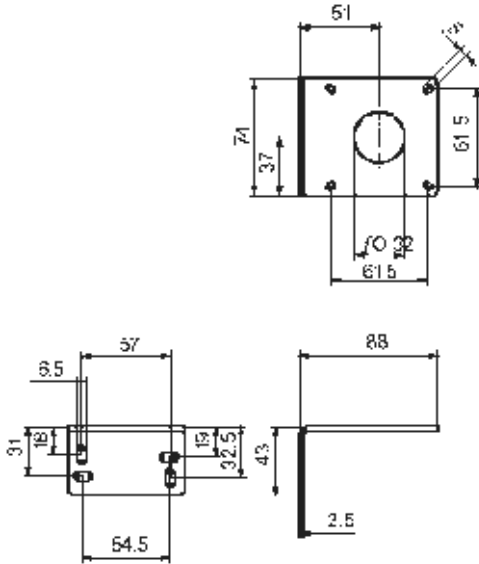

Order reference 491367



Order reference 491366

LUCIFER® EPP4 ACCESSORIES

POWER SUPPLY/CONTROL SIGNAL CABLE FOR BASIC AND COMFORT VERSIONS.

Cable for Basic EPP4

- 2 m cable with moulded straight M12-4 pole

Order Ref. P8L-MC04A2A-M12

Cable for Comfort EPP4

- 2 m cable with moulded straight M12-8 pole

Order Reference 496796



LUCIFER® EPP4 COMFORT ACCESSORIES

calys SOFTWARE

Calys is a unique software in house developed to configurate all the parameters of the EPP4 Comfort range. Calys is an option of the EPP4. A specific cable is needed for the communication between the EPP4 and a PC.



Calys offers many capabilities:

- Live monitoring (control signal, regulated pressure, supply voltage,...)
- Recording of the main parameters (control signal, regulated pressure, supply voltage,...) in an Excel file
- Free calibration for the inputs and outputs
- Adjustable alarm (positive-negative, pressure limits, delays)
- Configuration files easy to duplicate
- Complete and interactive help file
- Data in 4 different pressure units
- Menus in 4 languages (English, German, French and Italian)

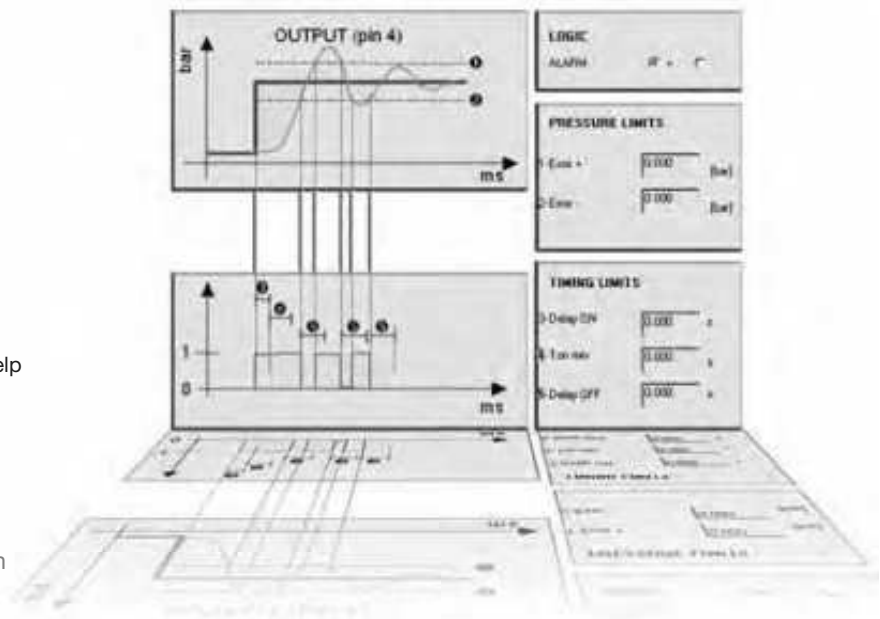

**Specific communication cable PC-EPP4
with RS232 and USB connection**

Order Reference 496449

This option is for safe area only.

To download free Calys software click on
www.parker.com/FCDE/Support

LUCIFER® EPP4 COMFORT ACCESSORIES

REMOTE DISPLAY

This option includes the Remote Display and 1.5 meter connecting cable. Connected to the pressure regulator, it offers flexible monitoring. This option only works with EPP4 0-10 bar.

Compact and highly readable remote LED display:

- Bar and PSI scales
- Security lock
- 1.5 m cable
- Mounting brackets

Order the Remote Display under reference 496490

This option is for safe area only.



PANEL MOUNTING KIT

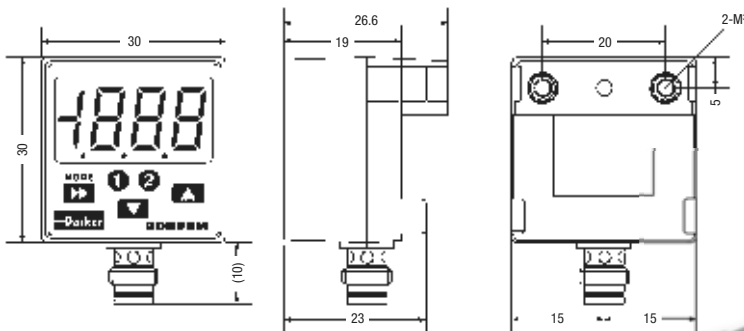

Order the Panel Mounting Kit under reference 496601