

# Needle Valve Actuators

## Pneumatic, Piston Type

For: MVE, P, 10V, SW, SM, SC, V, VM, QS,  
Needle Valves to 150,000 psi (10340 bar)



### Principle of Operation:

The need to control process and vent valves from a remote location makes air operated valves a vital component to many process applications.

All Parker Autoclave Engineer's needle valves are available with piston type pneumatic actuators. Six sizes of air actuators (light, mini-light, medium, heavy duty or extra heavy, single and double stage) are offered to meet the service requirements of Parker Autoclave Engineer's Low, Medium and High Pressure needle valves. Both air-to-open (normally closed) and air-to-close (normally open) designs are included in the product line. Dual acting Air-to-Open & Close actuators are also available.

For most Parker Autoclave Engineers valve series there is a choice of two or more actuator designs. This provides the most efficient and economical pneumatic valve operation for any combination of process requirements and available air pressure.

Actuators are available for outdoor service. These operators provide corrosion resistant components and prevent the ingress of outside elements. Weatherproof or Explosionproof (CUL/ATEX) Limit Switch position indication is available upon request.

### Features and Benefits:

- Fail Close (Air-to-Open) or Fail Open (Air-to-Close) with Spring Return
- Dual Acting (Air-to-Open & Close) actuators are available in all sizes except Mini-Light and Light. Note: Not Fail-Safe
- Piston actuator sizing incorporates maximum allowable air pressure of 100 psi
- Yoke design for separation of process and air pressure/allows for limit switch position indication
- Visual Valve Position Indicator as standard - Limit Switch options available
- Anodized Aluminum Housing (for corrosion and wear resistance)
- -20°F to 200°F (-29° to 93°C) ambient temperature range. (for operation below 30°F (-1°C) dry air must be used and heat tracing is recommended.)



ENGINEERING YOUR SUCCESS.

# General Information

## Pneumatic Piston Actuators

### Pneumatic Actuator:

Six sizes of air operators (light, mini-light, medium, heavy duty or extra heavy, single and double stage) are offered for remote on-off operation or automatic operation of Parker Autoclave Engineer's low, medium or high pressure valves. The actuators are available in air-to-open (normally closed) and air-to-close (normally open) designs.

### Remote On-Off:

Parker Autoclave Engineer's air-operated valves, ATO (Air-to-Open), ATC (Air-to-Close), or AOC (Dual Acting Air-to-Open & Close) pneumatic actuators can be controlled by a 3-way manual low pressure valve or by a 3-way low pressure solenoid valve (user supplied) mounted in the actuator supply air line. Parker Autoclave Engineer's air-operated, high pressure valves permit process control from a remotely located panel without the necessity of piping high pressure lines to the control panel. Safety is greatly increased and process "hysteresis" is reduced. Prudent selection of ATO or ATC valves, together with the air controlling devices, permit the system design to "fail safe" in either the closed or open condition in the event of loss of air pressure, or electrical failure, or malfunction. Where explosion proof conditions are a requirement, pneumatic actuated valves can be considered.

Duty Rating	Operator	Type	Ordering Suffix	Dimensions: inches (mm)	
				A	B
Light	Piston	Air -to-Open	OLP	5.50 (140)	2.81 (727)
		Air -to-Close	CLP	3.94 (100)	2.81 (72)
Mini Light	Piston	Air -to-Open	OHLP	3.84 (98)	3.06 (78)
		Air -to-Close	CHLP	2.61 (66)	3.06 (78)
Medium	Piston	Air -to-Open	O1S	8.25 (210)	5.69 (145)
		Air -to-Close	C1S	5.50 (140)	5.69 (145)
Heavy	Piston	Air -to-Open	O2S	11.88 (302)	5.69 (145)
		Air -to-Close	C2S	8.50 (216)	5.69 (145)
Extra Heavy Single Stage	Piston	Air -to-Open	HO1S	15.16 (385)	9.44 (240)
		Air -to-Close	HO1S	8.75 (218)	9.44 (240)
Extra Heavy Double Stage	Piston	Air -to-Open	HO2S	18.50 (470)	9.44 (240)
		Air -to-Close	HC2S	11.94 (303)	9.44 (240)

### Outdoor Service Actuators

Medium	Piston	Air -to-Open	O1SOD	8.25 (210)	5.69 (145)
		Air -to-Close	C1SOD	5.50 (140)	5.69 (145)
Heavy	Piston	Air -to-Open	O2SOD	11.88 (302)	5.69 (145)
		Air -to-Close	C2SOD	8.50 (216)	5.69 (145)
Extra Heavy Single Stage	Piston	Air -to-Open	HO1SOD	15.16 (385)	9.44 (240)
		Air -to-Close	HC1SOD	8.75 (218)	9.44 (240)
Extra Heavy Double Stage	Piston	Air -to-Open	HO2SOD	18.50 (470)	9.44 (240)
		Air -to-Close	HC2SOD	11.94 (303)	9.44 (240)

Dual Acting: For Dual Acting (Air-to-Open & Close) option, replace "O" or "C" suffix code character with a "D" (Not available in Mini-Light or Light actuator sizes) Dimensions are the same as the Air-to-Close type actuators.

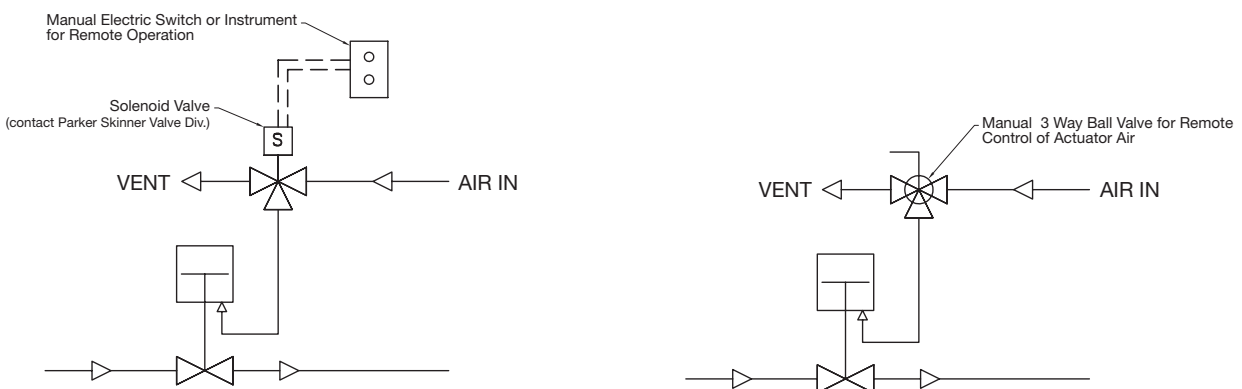

# Piston Type Valve Actuators

Piston type air-operated valves offer a unique, reliable design providing for a long and dependable life. These actuators are quick acting, typically less than one (1) second activation time (Dependent on air flow rate to piston and process pressure required at valve inlet) and long lasting (tested to over 100,000 cycles).

Parker Autoclave Engineer's piston type actuators feature:

- Air-to-Open (Inlet Pressure may be required) or Air-to-Close with spring return or Dual Acting (no spring) Options
- Anodized Aluminum Piston and Housing (100 psi max)
- Yoke design for separation of process and air drive sections for safety †
- Ease of stem replacement
- Stem position indicator is standard †
- High actuator cycle life with lifetime lubrication
- 1/8" NPT air inlet connection except Extra Heavy duty has 3/8" NPT
- Single or Dual (Open & Close) Limit Switch options are available in Weatherproof, Explosionproof (Class 1, Division 1, Groups C & D, Temp. Group T6) versions. Consult Factory

**Note:** Air supply to Air-to-Close Actuator must be regulated to the pressure shown in subsequent charts based on application pressure. Air pressure over required pressure may damage valve seat.

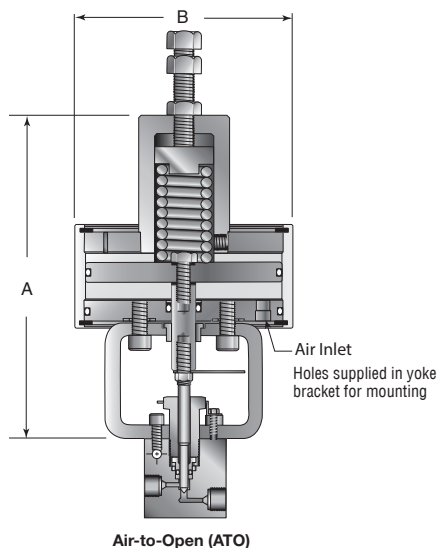

**Air-to-Open (ATO)**

NOTE: Air inlet for air to open operator is located in the back, opposite the front of valve. For other locations, consult factory.

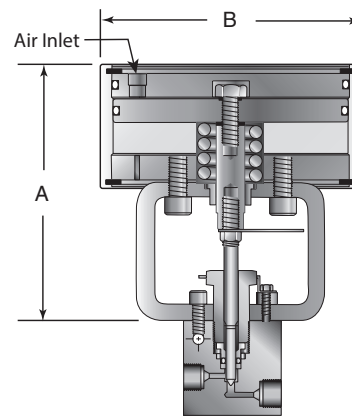

**Air-to-Close (ATC)**

† The standard Mini-Light operator does not utilize the yoke design. A yoke design is available upon request.

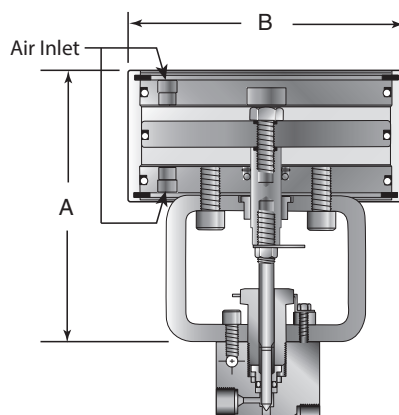

**Dual Acting, Air-to-Open and Close**  
(Not available in Light or Mini-Light versions)

**Note:**  
See "Yoke Mounting Dimensions" on page 17 should these mounting points be preferred instead of valve body mounting holes.

# Technical Detail

## Air Operated Materials:

Cylinder, piston, cover plates, spring housing: Anodized aluminum (for corrosion and wear resistance).  
Yoke: Painted Steel

## Technical Data:

### Air Operator

- Maximum allowable working pressure: 100 psi (6.89 bar)
- Allowable piston temperature range: -20°F to 200°F (-29°C to 93°C), operating below 30°F (-1.1°C) with dry air only (heat trace may be needed for lower temperatures).
- Area of piston:
  - Light duty - 4.9 sq. in (31.6 sq. cm)
  - Mini-Light duty - 5.4 sq. in (34.8 sq. cm)
  - Medium duty - 19.6 sq. in (126.5 sq. cm)
  - Heavy duty - 39.2 sq. in (252.9 sq. cm)
  - Extra Heavy duty single stage - 56 sq. in (361.3 sq. cm)
  - Extra Heavy duty double stage - 112 sq. in (722.6 sq. cm)
- Approximate air usage/cycle @ 100 psi (6.89 bar) - For Dual Acting, double air usage shown below:
  - Light duty - .003 SCF (.00008 SCM)
  - Mini-Light duty - .007 SCF (.0002 SCM)
  - Medium duty - .04 SCF (.0011 SCM)
  - Heavy duty - .08 SCF (.0022 SCM)
  - Extra Heavy duty single stage - .33 SCF (.0095 SCM)
  - Extra Heavy duty double stage - .67 SCF (.019 SCM)
- Tested to 100,000 cycles at 100 psi (6.89 bar) with no leakage or signs of wear or fatigue.

## To select Air-to-Close Needle Valve Actuator:

### Example:

Need to know: Valve Model/Connection Size - **20SM9071 Needle Valve**  
Indoor or Outdoor Service - **Outdoor Service**  
Maximum Operating Pressure: **Fluid - 12,000 psi**  
Maximum Available Air Pressure - **60 psi**  
Select Actuator Type : Air-to-Close type (Normally Open)

**Example:** Using chart on page 6 (Air-to-Close Actuators), select **20SM9 Section**

Across top of chart, select **12 Ksi System Pressure** (12,000 psi max system pressure)

Go down that column to **20SM9 Section** to first row filled with number (air pressure)

First row with number is **55** – as your available **air pressure is 60 psi**, you do not have to go any further (if this number was more than 60, continue to next row)

This row (**Heavy Duty Actuator**) confirms that this actuator needs 55 psi to close the 20SM9 valve at 12,000 psi and you have 60 psi available. Suffix code for this actuator can be found in this chart or on page 4 - find “Heavy Duty - Air-to-Close” - Suffix code is “**-C2SOD**”, remembering the Service location was “Outdoor” - add this suffix to the 20SM9 body style of your choice. **Example: 20SM9071-C2SOD**

**CAUTION:** While testing has shown O-rings to provide satisfactory service life, both cyclic and shelf life may vary widely with differing service conditions, properties of reactants, pressure and temperature cycling and age of the O-ring, **FREQUENT INSPECTIONS SHOULD BE MADE** to detect any deterioration, and O-rings replaced as required. \*Maximum pressure rating is based on the lowest rating of any component. Actual working pressure may be determined by tubing pressure rating, if lower.

# Air Operator Sizing Data

Air To Close

## Series MVE Valves

Valve Series	Operator Duty		System Pressure KSI (bar)								Maximum Pressure psi (bar)*	Stem Travel in (mm)	Flow Coefficient***	
			1 to 6 (410)	8 (550)	10 (690)	12 (830)	14 (970)	15 (1035)						
MVE1	Mini-Light Duty -OHP	Air Pressure psi (bar)	75 (5)	75 (5)	80 (6)	90 (6)	95 (7)	100 (7)				15,000 (1035)	.094 (2)	0.05
MVE2														.094 (2)

## Series 10V and SW Valves

Valve Series	Operator Duty		System Pressure KSI (bar)								Maximum Pressure psi (bar)*	Stem Travel in (mm)	Flow Coefficient***	
			1 to 4 (275)	6 (410)	8 (550)	10 (690)	12 (830)	14 (970)	15 (1035)					
10V2	Light Duty -CLP	Air Pressure psi (bar)	30 (2)	40 (3)	55 (4)	65 (4)	85 (6)	95 (7)	100 (7)			15,000 (1035)	.16 (4)	.12
	Medium Duty -C1S		25 (2)	25 (2)	25 (2)	25 (2)	25 (2)	25 (2)	30 (2)					
SW4	Medium Duty -C1S		40 (3)	40 (3)	40 (3)	50 (3)	55 (4)	60 (4)	65 (4)			15,000 (1035)	.25 (6)	.65
SW6	Medium Duty -C1S		50 (3)	50 (3)	55 (4)	70 (5)	75 (5)	85 (6)	90 (6)			15,000 (1035)	.25 (6)	.95
	Heavy Duty -C2S		20 (1)	25 (2)	30 (2)	35 (2)	40 (3)	45 (3)	50 (3)			15,000 (1035)		
SW8	Medium Duty -C1S		65 (4)	70 (5)	100 (7)							8,000 (552)	.38 (10)	1.90
	Heavy Duty -C2S		35 (2)	35 (2)	50 (3)	60 (4)						10,000 (690)		

## Series 15SM Valves (replaces 10SM Valves)

Valve Series	Operator Duty		System Pressure KSI (bar)								Maximum Pressure psi (bar)*	Stem Travel in (mm)	Flow Coefficient**	
			4 (275)	6 (410)	8 (550)	10 (690)	12 (830)	14 (970)	16 (1100)	18 (1240)				20 (1380)
15SM9 15QS9	Medium Duty -C1S	Air Pressure psi (bar)	65 (4)	75 (5)	100 (7)							8,600 (593)	.38 (10)	1.75
	Heavy Duty -C2S		35 (2)	40 (3)	50 (3)	55 (4)	60 (4)	70 (5)	75 (5.2)			15,000 (1035)		
	Extra Heavy Duty Single Stage -HC1S		30 (2)	30 (2)	35 (2)	45 (3)	50 (3.5)	55 (3.8)	60 (4.2)			15,000 (1035)		
	Extra Heavy Duty Two Stage -HC2S		15 (1)	15 (1)	20 (1)	20 (1)	25 (1.7)	30 (2)	35 (2.4)			15,000 (1035)		
15SM12 15QS12	Heavy Duty -C2S	Air Pressure psi (bar)	45 (3)	60 (4)	80 (6)	100 (7)						10,000 (690)	.44 (11)	2.80
	Extra Heavy Duty Single Stage -HC1S		35 (2)	50 (3)	60 (4)	70 (5)	80 (5.5)	95 (6.5)	100 (6.9)			15,000 (1035)		
	Extra Heavy Duty Two Stage -HC2S		20 (1)	25 (2)	30 (2)	35 (2)	40 (2.8)	45 (3.1)	50 (3.5)			15,000 (1035)		

\* Maximum pressure rating is based on the lowest rating of any components. Actual working pressure may be determined by tubing pressure rating, if lower.

\*\* C<sub>v</sub> data is for 2-way straight valves. For angle pattern add approximately 50% to the C<sub>v</sub> value.

# Air Operator Sizing Data

Air To Close

## Series 15SM Valves (con't)

Valve Series	Operator Duty	System Pressure KSI (bar)										Maximum Pressure psi (bar)*	Stem Travel in (mm)	Flow Coefficient**
		1 to 3 (210)	4 (280)	6 (410)	8 (550)	10 (690)	12 (830)	14 (970)	16 (1100)	18 (1240)	20 (1380)			
15SM16 15QS16	Extra Heavy Duty Single Stage -HC1S	Air Pressure psi (bar)	45 (3)	50 (3)	70 (5)	95 (7)						8,500 (586)	.56 (14)	5.20
	Extra Heavy Duty Two Stage -HC2S		25 (2)	25 (2)	35 (2)	45 (3)	55 (4)	65 (4.5)				12,500 (860)		
15SM24	Extra Heavy Duty Two Stage -HC2S		35 (2)	40 (3)	55 (4)	75 (5)	90 (6)					10,000 (690)	.75 (19)	14

## Series 20SM Valves

Valve Series	Operator Duty	System Pressure KSI (bar)										Maximum Pressure psi (bar)*	Stem Travel in (mm)	Flow Coefficient**
		4 (280)	6 (410)	8 (550)	10 (690)	12 (830)	14 (970)	16 (1100)	18 (1240)	20 (1380)				
20SM4 15P4† 15QS4	Medium Duty -C1S	Air Pressure psi (bar)	40 (3)	40 (3)	40 (3)	50 (3)	60 (4)	70 (5)	80 (6)	85 (6)	90 (7)	20,000 (1380)	.25 (6)	.31
	Heavy Duty -C2S		20 (1)	20 (1)	20 (1)	25 (2)	30 (2)	35 (2)	40 (3)	45 (3)	50 (3)			
20SM6 15P6† 15QS6	Medium Duty -C1S		45 (3)	45 (3)	45 (3)	55 (4)	65 (4)	75 (5)	85 (6)	95 (7)	100 (7)	19,000 (1310)	.25 (6)	.75
	Heavy Duty -C2S	25 (2)	25 (2)	25 (2)	30 (2)	35 (2)	40 (3)	45 (3)	50 (3)	55 (4)	20,000 (1380)			
20SM9 15P8†	Medium Duty -C1S	60 (4)	65 (4)	80 (6)	100 (7)						10,700 (738)	.38 (10)	1.30	
	Heavy Duty -C2S	30 (2)	30 (2)	40 (3)	50 (3)	55 (4)	60 (4)	70 (5)	80 (6)	85 (6)	20,000 (1380)			
	Extra Heavy Duty Single Stage -HC1S	25 (2)	25 (2)	30 (2)	35 (2)	45 (3)	50 (3)	55 (4)	60 (4)	65 (4)	20,000 (1380)			
20SM12 10P12†	Medium Duty -C1S	80 (5)	100 (7)								6,100 (421)	.44 (11)	2.50	
	Heavy Duty -C2S	40 (3)	50 (3)	60 (4)	75 (5)	90 (6)	100 (7)				13,600 (938)			
	Extra Heavy Duty Single Stage -HC1S	30 (2)	40 (3)	50 (3)	60 (4)	65 (4)	75 (5)	85 (6)	95 (7)	100 (7)	19,000 (1310)			
	Extra Heavy Duty Two Stage -HC2S	15 (1)	20 (1)	25 (2)	30 (2)	35 (2)	40 (3)	45 (3)	50 (3)	50 (3)	20,000 (1380)			

\* Maximum pressure rating is based on the lowest rating of any components. Actual working pressure may be determined by tubing pressure rating, if lower.

\*\* Cv data is for 2-way straight valves. For angle pattern add approximately 50% to the Cv value. † Maximum rating based on the valve rating.

# Air Operator Sizing Data

Air To Close

## Series 20SM Valves

Valve Series	Operator Duty	System Pressure KSI (bar)									Maximum Pressure psi (bar)*	Stem Travel in (mm)	Flow Coefficient**			
		4 (280)	6 (410)	8 (550)	10 (690)	12 (830)	14 (970)	16 (1100)	18 (1240)	20 (1380)						
20SM16 10P16†	Heavy Duty -C2S	Air Pressure psi (bar)	50 (3)	70 (5)	100 (7)									8,800 (607)	.56 (14)	3.40
	Extra Heavy Duty, Single Stage -HC1S		40 (3)	55 (4)	70 (5)	85 (6)	100 (7)							12,500 (860)		
	Extra Heavy Duty, Two Stage -HC2S		20 (1)	25 (2)	35 (2)	40 (3)	50 (3)	55 (4)	60 (4)	70 (5)	75 (5)					

\* Maximum pressure rating is based on the lowest rating of any components. Actual working pressure may be determined by tubing pressure rating, if lower.

\*\* C<sub>v</sub> data is for 2-way straight valves. For angle pattern add approximately 50% to the C<sub>v</sub> value. † Maximum rating based on the valve rating.

## Series 30SC, 43SC Valves

Valve Series	Operator Duty	System Pressure KSI (bar)													Maximum Pressure psi (bar)*	Stem Travel in (mm)	Flow Coefficient**
		1 to 10 (690)	15 (1035)	16 (1100)	18 (1240)	20 (1380)	22 (1520)	24 (1650)	26 (1790)	28 (1930)	30 (2060)	35 (2410)	40 (2760)				
30SC16	Extra Heavy Duty, Two Stage -HC2S	Air Pressure psi (bar)	30 (2)	40 (3)	45 (3)	50 (3)	55 (4)	60 (4)	65 (5)	70 (5)	75 (5)	80 (6)			30,000 (2070)	.50 (13)	2.61
43SC16 (see note)	Extra Heavy Duty, Two Stage -HC2S		30 (2)	40 (3)	45 (3)	50 (3)	55 (4)	55 (4)	60 (4)	65 (4)	70 (5)	75 (5)	85 (6)	95 (7)	*** 40,000 (2760)	.52 (13)	2.61

Note: \*\*\* Maximum pressure with actuator 40,000 psi use actuators -HC2S.4 (valve orifice .406" diameter)

## Series 30VM Valves

Valve Series	Operator Duty	System Pressure KSI (bar)										Maximum Pressure psi (bar)*	Stem Travel in (mm)	Flow Coefficient**	
		12 (830)	14 (970)	16 (1100)	18 (1240)	20 (1380)	22 (1520)	24 (1650)	26 (1790)	28 (1930)	30 (2070)				
30VM4	Medium Duty -C1S	Air Pressure psi (bar)	25 (2)	25 (2)	30 (2)	35 (2)	35 (2)	40 (3)	45 (3)	50 (3)	50 (3)	55 (4)	30,000 (270)	.19 (5)	.12
	Heavy Duty -C2S		15 (1)	15 (1)	15 (1)	20 (1)	20 (1)	20 (1)	25 (2)	25 (2)	25 (2)	30 (2)			
30VM6 and 30VM9	Medium Duty -C1S		30 (2)	25 (2)	40 (3)	45 (3)	50 (3)	55 (4)	60 (4)	65 (4)	70 (5)	75 (5)	30,000 (270)	.19 (5)	.23 (30VM6)
	Heavy Duty -C2S		15 (1)	20 (1)	20 (1)	25 (2)	25 (2)	30 (2)	30 (2)	35 (2)	35 (2)	40 (3)			.33 (30VM9)

# Air Operator Sizing Data

Air To Close

## Series 40VM Valves

Valve Series	Operator Duty	System Pressure KSI (bar)										Maximum Pressure psi (bar)*	Stem Travel in (mm)	Flow Coefficient**	
		1-10 (7-69)	15 (103)	20 (138)	25 (172)	30 (207)	35 (241)	40 (276)							
40VM9	Medium Duty -C1S	Air Pressure psi (bar)	40 (3)	50 (4)	60 (4)	70 (5)	80 (6)	90 (6)	90 (7)				40,000 (2760)	.25 (6)	.28
	Heavy Duty -C2S		20 (1)	25 (2)	30 (2)	35 (2)	40 (3)	45 (3)	45 (3)						

## Series 60VM Valves

Valve Series	Operator Duty	System Pressure KSI (bar)										Maximum Pressure psi (bar)*	Stem Travel in (mm)	Flow Coefficient**	
		1 to 20 (138)	25 (173)	30 (207)	35 (241)	40 (276)	45 (310)	50 (345)	55 (380)	60 (414)					
60VM4 and 60VM6	Medium Duty -C1S	Air Pressure psi (bar)	30 (2)	30 (2)	35 (2)	45 (3)	50 (4)	55 (4)	60 (4)	70 (5)	75 (5)		60,000 (4136)	.25 (6.35)	.08 (60VM4)
	Heavy Duty -C2S		15 (1)	15 (1)	20 (1)	25 (2)	25 (2)	30 (2)	30 (2)	35 (2)	40 (3)				.09 (60VM6)
60VM9	Medium Duty -C1S		35 (2)	40 (3)	50 (4)	55 (4)	65 (4)	70 (5)	75 (5)	85 (6)	90 (6)		60,000 (4136)	.25 (6.35)	0.14
	Heavy Duty -C2S		20 (1)	20 (1)	25 (1)	30 (2)	35 (2)	35 (2)	40 (3)	45 (3)	45 (3)				

## Series 100VM AND 150V Valves

Valve Series	Operator Duty	System Pressure KSI (bar)										Maximum Pressure psi (bar)*	Stem Travel in (mm)	Flow Coefficient**	
		1 to 40 (2760)	50 (3450)	60 (4140)	70 (4830)	80 (5520)	90 (6210)	100 (6890)	150 (10350)						
100VM4 100VM5 100VM6	Medium Duty -C1S	Air Pressure psi (bar)	50 (3)	55 (4)	65 (4)	75 (5)	85 (6)	95 (7)	100 (689)				100,000 (6900)	.12 (3)	.09
	Heavy Duty -C2S		30 (2)	30 (2)	35 (2)	40 (3)	40 (3)	45 (3)	50 (3)						
100VM9	Extra Heavy Duty (Two Stage) -HC2S		-	-	45 (3)	50 (3)	60 (4)	65 (4)	70 (5)				100,000 (6900)	.44 (11)	.65
150V5	Heavy Duty -C2S		35 (2)	40 (3)	45 (3)	45 (3)	50 (3)	55 (4)	60 (4)	100 (7)			150,000 (10350)	.12 (3)	.06

\* Maximum pressure rating is based on the lowest rating of any components. Actual working pressure may be determined by tubing pressure rating, if lower.

\*\* C<sub>v</sub> data is for 2-way straight valves. For angle pattern add approximately 50% to the C<sub>v</sub> value. † Maximum rating based on the valve rating.

CAUTION: While testing has shown O-rings to provide satisfactory service life, both cyclic and shelf life may vary widely with differing service conditions, properties of reactants, pressure and temperature cycling and age of the O-ring, FREQUENT INSPECTIONS SHOULD BE MADE to detect any deterioration, and O-rings replaced as required.



# Air Operator Sizing Data

Air To Open (Inlet Pressure Assist may be required on some options)

## Series MVE Valves

Valve Series	Operator Duty		System Pressure KSI (bar)								Maximum Pressure psi (bar)*	Flow Coefficient**	
			1-6 (7-41)	8 (55)	10 (69)	12 (83)	14 (97)	15 (103)					
MVE1	Mini-Light Duty -OHLF	Air Pressure psi (bar)	100 (7)	100 (47)	100 (47)	100 (47)	100 (47)	100 (7)				15,000 (1035)	.05
		Spring Pre-Compression in (mm)	.13 (3)	.13 (3)	.13 (3)	.16 (4)	.19 (5)	.20 (5)					
MVE2		Stem travel in (mm)	.16 (4)	.16 (4)	.16 (4)	.13 (3)	.10 (2)	.09 (2)					.11

## Series 10V Valves

Valve Series	Operator Duty		System Pressure KSI (bar)								Maximum Pressure psi (bar)*	Flow Coefficient**	
			1 to 6 (410)	8 (550)	10 (690)	12 (830)	14 (970)	15 (1035)					
10V2	Light Duty -OLP	Air Pressure psi (bar)	60 (4)	60 (4)								8,200 (565)	.12 to .09***
		Spring Pre-Compression in (mm)	.31 (8)	.38 (10)									
		Stem travel in (mm)	.12 (3)	.06 (2)									
	Medium Duty -O1S	Air Pressure psi (bar)	40 (3)	40 (3)	40 (3)	40 (3)	40 (3)	45 (3)				15,000 (1035)	.12
		Spring Pre-Compression in (mm)	.12 (3)	.12 (3)	.12 (3)	.12 (3)	.12 (3)	.16 (4)					
		Stem travel in (mm)	.12 (3)	.12 (3)	.12 (3)	.12 (3)	.12 (3)	.12 (3)					

\* Maximum pressure rating is based on the lowest rating of any components. Actual working pressure may be determined by tubing pressure rating, if lower.

\*\* C<sub>v</sub> data is for 2-way straight valves. For angle pattern add approximately 50% to the C<sub>v</sub> value.

\*\*\* C<sub>v</sub> varies because of spring compression limitations. The flow coefficient range is given for the maximum stem travel (lowest system pressure) to minimum travel (highest system pressure).

## To select Air-to-Open Needle Valve Actuator:

### Example:

Need to know: Valve Model/Connection Size - **20SM9071 Needle Valve**  
 Indoor or Outdoor Service - **Indoor Service**  
 Maximum Operating Pressure: **Fluid - 12,000 psi**  
 Maximum Available Air Pressure - **60 psi**  
 Select Actuator Type : Air-to-Open (Normally Closed)

**Example:** Using chart on page 12 (Air-to-Open Actuators), select **20SM9 Section**

Across top of chart, select **12 Ksi System Pressure** (12,000 psi max system pressure)

Go down that column to **20SM9 Section** to first row filled with number (Actuator air pressure needed)

First row with number is **75 (corresponding to Heavy Duty Actuator)**, – as your available air pressure is **60 psi**, you must go down to next actuator section where it shows that the Extra HD Single Stage actuator only needs 60 psi to actuate.

This row (- **Extra HD Single Stage Actuator**) confirms that this actuator needs 60 psi to open the 20SM9 valve at 12,000 psi and as you have 60 psi available. Suffix code for this actuator can be found in this chart or on page 2 - find “Extra Heavy Duty Single Stage - Air-to-Open” - Suffix code is “-**HO1S**”, remembering the Service location was “Indoor” (which is standard) - add this suffix to the 20SM9 body style of your choice. **Example: 20SM9071-HO1S**

**CAUTION:** While testing has shown O-rings to provide satisfactory service life, both cyclic and shelf life may vary widely with differing service conditions, properties of reactants, pressure and temperature cycling and age of the O-ring, **FREQUENT INSPECTIONS SHOULD BE MADE** to detect any deterioration, and O-rings replaced as required. \*Maximum pressure rating is based on the lowest rating of any component. Actual working pressure may be determined by tubing pressure rating, if lower.

# Air Operator Sizing Data

Air To Open (Inlet Pressure Assist may be required on some options)

## Series SW Valves

Valve Series	Operator Duty		System Pressure KSI (bar)								Maximum Pressure psi (bar)*	Flow Coefficient**	
			1 to 6 (410)	8 (550)	10 (690)	12 (830)	14 (970)	15 (1030)					
SW4	Medium Duty -O1S	Air Pressure psi (bar)	65 (4)	65 (4)	75 (5)	85 (6)	95 (7)	95 (7)				15,000 (1035)	.65*
		Spring Pre-Compression in (mm)	.19 (5)	.19 (5)	.25 (6)	.31 (8)	.36 (9)	.38 (9)					
		Stem travel in (mm)	.25 (6)	.25 (6)	.25 (6)	.25 (6)	.25 (6)	.25 (6)					
SW6	Medium Duty -O1S	Air Pressure psi (bar)	75 (5)	75 (5)	95 (7)	95 (7)	95 (7)					13,500 (931) (Spring is fully compressed)	.62 to .95 ***
		Spring Pre-Compression in (mm)	.25 (6)	.25 (6)	.28 (7)	.44 (11)	.52 (13)						
		Stem travel in (mm)	.25 (6)	.25 (6)	.25 (6)	.19 (5)	.10 (3)						
	Heav Duty -O2S	Air Pressure psi (bar)	50 (3)	55 (4)	60 (4)	65 (4)	70 (5)	75 (5)				15,000 (1035)	.95
		Spring Pre-Compression in (mm)	.14 (4)	.19 (5)	.24 (6)	.28 (7)	.34 (9)	.36 (9)					
		Stem travel in (mm)	.25 (6)	.25 (6)	.25 (6)	.25 (6)	.25 (6)	.25 (6)					
SW8	Medium Duty -O1S	Air Pressure psi (bar)	95 (7)	95 (7)								7,200 (469) (Spring is fully compressed)	1.75
		Spring Pre-Compression in (mm)	.38 (10)	.56 (14)									
		Stem travel in (mm)	.25 (6)	.05 (2)									
	Heavy Duty -O2S	Air Pressure psi (bar)	65 (4)	75 (5)	75 (5)							10,000 (690)	1.14
		Spring Pre-Compression in (mm)	.28 (7)	.38 (10)	.44 (1)								
		Stem travel in (mm)	.25 (6)	.25 (6)	.19 (5)								

\* Maximum pressure rating is based on the lowest rating of any components. Actual working pressure may be determined by tubing pressure rating, if lower.

\*\* C<sub>v</sub> data is for 2-way straight valves. For angle pattern add approximately 50% to the C<sub>v</sub> value.

\*\*\* C<sub>v</sub> varies because of spring compression limitations. The flow coefficient range is given for the maximum stem travel (lowest system pressure) to minimum travel (highest system pressure).

CAUTION: While testing has shown O-rings to provide satisfactory service life, both cyclic and shelf life may vary widely with differing service conditions, properties of reactants, pressure and temperature cycling and age of the O-ring, FREQUENT INSPECTIONS SHOULD BE MADE to detect any deterioration, and O-rings replaced as required. All dimensions for reference only and subject to change. For prompt service, Parker Autoclave Engineers stocks select products. Consult your local representative.

# Air Operator Sizing Data

Air To Open (Inlet Pressure Assist may be required on some options)

## Series 15SM Valves (replaces 10SM Valves)

Valve Series	Operator Duty		System Pressure KSI (bar)							Maximum Pressure psi (bar)*	Flow Coefficient**
			1 to 4 (280)	6 (410)	8 (550)	10 (690)	12 (830)	14 (970)	16 (1100)		
15SM9 15QS9	Heavy Duty -O2S	Air Pressure psi (bar)	60 (4)	65 (4)	75 (5)	80 (5.5)	80 (5.5)			12,000 (830)	1.74 to .72***
		Spring Pre-Compression in (mm)	.22 (6)	.28 (7)	.35 (9)	.44 (11)	.53 (13)				
		Stem travel in (mm)	.25 (6)	.25 (6)	.25 (6)	.19 (5)	.10 (3)				
	Extra Heavy Duty Single Stage -HO1S	Air Pressure psi (bar)	45 (4)	50 (3.5)	55 (4)	65 (4.5)	70 (5)	75 (5)	80 (5.5)	15,000 (1035)	1.75
		Spring Pre-Compression in (mm)	.31 (8)	.35 (9)	.47 (12)	.59 (15)	.70 (18)	80 (25)	88 (22.5)		
		Stem travel in (mm)	.38 (10)	.38 (10)	.38 (10)	.38 (10)	.38 (10)	.38 (10)	.38 (10)		
	Extra Heavy Duty Two Stage -HO2S	Air Pressure psi (bar)	35 (2.5)	35 (2.5)	40 (3)	40 (3)	45 (3)	50 (3.5)	55 (4)	15,000 (1035)	1.75
		Spring Pre-Compression in (mm)	.16 (4)	.19 (5)	.23 (6)	.28 (7)	.35 (9)	.41 (10)	.44 (11)		
		Stem travel in (mm)	.38 (10)	.38 (10)	.38 (10)	.38 (10)	.38 (10)	.38 (10)	.38 (10)		
15SM12 15QS12	Extra Heavy Duty Single Stage -HO1S	Air Pressure psi (bar)	55 (4)	65 (5)	80 (6)	95 (7)	100 (7)			12,000 (830)	2.80
		Spring Pre-Compression in (mm)	.44 (11)	.63 (16)	.84 (21)	1.06 (27)	1.25 (32)				
		Stem travel in (mm)	.44 (11)	.44 (11)	.44 (11)	.44 (11)	.32 (8)				
	Extra Heavy Duty Two Stage -HO2S	Air Pressure psi (bar)	40 (3)	50 (4)	55 (4)	60 (4)	70 (5)	75 (5)	75 (5)	15,000 (1035)	2.80
		Spring Pre-Compression in (mm)	.22 (6)	.31 (8)	.44 (11)	.63 (16)	.63 (16)	.74 (19)	.80 (20)		
		Stem travel in (mm)	.44 (11)	.44 (11)	.44 (11)	.44 (11)	.44 (11)	.44 (11)	.40 (10)		
15SM16 15QS16	Extra Heavy Duty Single Stage -HO1S	Air Pressure psi (bar)	75 (5)	100 (7)						6,500 (448) (Spring is fully compressed)	5.20
		Spring Pre-Compression in (mm)	.69 (18)	1.13 (29)							
		Stem travel in (mm)	.50 (13)	.50 (13)							
	Extra Heavy Duty Two Stage -HO2S	Air Pressure psi (bar)	55 (4)	65 (4)	75 (5)	85 (6)				10,000 (689) (Spring is fully compressed)	5.20
		Spring Pre-Compression in (mm)	.34 (9)	.53 (13)	.69 (18)	.88 (22)					
		Stem travel in (mm)	.50 (13)	.50 (13)	.50 (13)	.50 (13)					
15SM24	Extra Heavy Duty Two Stage -HO2S	Air Pressure psi (bar)	65 (2)	85 (6)	90 (6)	100 (7)				9,000 (621)	14
		Spring Pre-Compression in (mm)	.60 (15)	.89 (22.5)	1.19 (30)	1.34 (34)					
		Stem travel in (mm)	.44 (11)	.44 (11)	.25 (6)	.25 (6)					

\* Maximum pressure rating is based on the lowest rating of any components. Actual working pressure may be determined by tubing pressure rating, if lower.

\*\* C<sub>v</sub> data is for 2-way straight valves. For angle pattern add approximately 50% to the C<sub>v</sub> value.

\*\*\* C<sub>v</sub> varies because of spring compression limitations. The flow coefficient range is given for the maximum stem travel (lowest system pressure) to minimum travel (highest system pressure).

CAUTION: While testing has shown O-rings to provide satisfactory service life, both cyclic and shelf life may vary widely with differing service conditions, properties of reactants, pressure and temperature cycling and age of the O-ring, FREQUENT INSPECTIONS SHOULD BE MADE to detect any deterioration, and O-rings replaced as required. All dimensions for reference only and subject to change. For prompt service, Parker Autoclave Engineers stocks select products. Consult your local representative.

# Air Operator Sizing Data

Air To Open (Inlet Pressure Assist may be required on some options)

## Series 20SM Valves

Valve Series	Operator Duty		System Pressure KSI (bar)								Maximum Pressure psi (bar)*	Flow Coefficient**	
			1-4 (280)	6 (410)	8 (550)	10 (690)	12 (830)	14 (970)	16 (1100)	18 (1240)			20 (1380)
20SM4 15P4† 15QS4	Medium Duty -O1S	Air Pressure psi (bar)	65 (4)	65 (4)	65 (4)	75 (5)	85 (6)	95 (7)	95 (7)	95 (7)	95 (7)	20,000 (1380)	.31 to .22***
		Spring Pre-Compression in (mm)	.19 (5)	.19 (5)	.19 (5)	.25 (6)	.31 (8)	.38 (10)	.44 (11)	.50 (13)	.56 (14)		
		Stem travel in (mm)	.25 (6)	.25 (6)	.25 (6)	.25 (6)	.25 (6)	.25 (6)	.19 (5)	.12 (3)	.06 (2)		
	Heavy Duty -O2S	Air Pressure psi (bar)	35 (3)	35 (3)	35 (3)	40 (3)	45 (3)	50 (3)	50 (3)	50 (3)	50 (3)		
20SM6 15P6† 15QS6	Medium Duty -O1S	Air Pressure psi (bar)	65 (4)	65 (4)	75 (5)	85 (6)	95 (7)	95 (7)	95 (7)	95 (7)		18,250 (1258) (Spring is fully compressed)	.75 to .57***
		Spring Pre-Compression in (mm)	.19 (5)	.19 (5)	.25 (6)	.31 (8)	.38 (10)	.44 (11)	.50 (13)	.56 (14)			
		Stem travel in (mm)	.25 (6)	.25 (6)	.25 (6)	.25 (6)	.25 (6)	.19 (5)	.12 (3)	.06 (2)			
	Heavy Duty -O2S	Air Pressure psi (bar)	35 (2)	35 (2)	40 (3)	45 (3)	50 (3)	50 (3)	50 (3)	50 (3)			
20SM9 15P8†	Medium Duty -O1S	Air Pressure psi (bar)	85 (6)	90 (6)	95 (7)	95 (7)						9,800 (676) (Spring is fully compressed)	1.29 to .53***
		Spring Pre-Compression in (mm)	.31 (8)	.34 (9)	.47 (12)	.56 (14)							
		Stem travel in (mm)	.25 (6)	.25 (6)	.15 (4)	.06 (2)							
	Heavy Duty -O2S	Air Pressure psi (bar)	50 (6)	55 (4)	65 (4)	70 (5)	75 (5)	75 (5)	75 (5)			15,700 (1082) (Spring is fully compressed)	1.29 to .53***
		Spring Pre-Compression in (mm)	.19 (5)	.22 (6)	.28 (7)	.34 (9)	.44 (11)	.50 (13)	.56 (14)				
		Stem travel in (mm)	.25 (6)	.25 (6)	.25 (6)	.25 (6)	.19 (5)	.12 (3)	.06 (2)				
	Extra Heavy Duty Single Stage -HO1S	Air Pressure psi (bar)	40 (3)	40 (3)	50 (3)	55 (4)	60 (4)	65 (4)	70 (5)	75 (5)	85 (6)	20,000 (1379)	1.30
		Spring Pre-Compression in (mm)	.25 (6)	.28 (7)	.38 (10)	.47 (12)	.56 (14)	.66 (17)	.75 (19)	.84 (21)	.94 (24)		
		Stem travel in (mm)	.38 (10)	.38 (10)	.38 (10)	.38 (10)	.38 (10)	.38 (10)	.38 (10)	.38 (10)	.38 (10)		
	Extra Heavy Duty Two Stage -HO2S	Air Pressure psi (bar)	30 (2)	35 (2)	35 (2)	40 (3)	40 (3)	45 (3)	50 (3)	50 (3)	55 (4)	20,000 (1379)	1.30
Spring Pre-Compression in (mm)		.13 (3)	.16 (4)	.19 (5)	.25 (6)	.28 (7)	.34 (9)	.38 (10)	.44 (11)	.47 (12)			
Stem travel in (mm)		.38 (10)	.38 (10)	.38 (10)	.38 (10)	.38 (10)	.38 (10)	.38 (10)	.38 (10)	.38 (10)			

\* Maximum pressure rating is based on the lowest rating of any components. Actual working pressure may be determined by tubing pressure rating, if lower.

\*\* C<sub>v</sub> data is for 2-way straight valves. For angle pattern add approximately 50% to the C<sub>v</sub> value.

\*\*\* C<sub>v</sub> varies because of spring compression limitations. The flow coefficient range is given for the maximum stem travel (lowest system pressure) to minimum travel (highest system pressure).

CAUTION: While testing has shown O-rings to provide satisfactory service life, both cyclic and shelf life may vary widely with differing service conditions, properties of reactants, pressure and temperature cycling and age of the O-ring. FREQUENT INSPECTIONS SHOULD BE MADE to detect any deterioration, and O-rings replaced as required. All dimensions for reference only and subject to change. For prompt service, Parker Autoclave Engineers stocks select products. Consult your local representative.

# Air Operator Sizing Data

Air To Open (Inlet Pressure Assist may be required on some options)

## Series 20SM Valves

Valve Series	Operator Duty		System Pressure KSI (bar)									Maximum Pressure psi (bar)*	Flow Coefficient**
			1-4 (280)	6 (410)	8 (550)	10 (690)	12 (830)	14 (970)	16 (1100)	18 (1240)	20 (1380)		
20SM12 10P12†	Heavy Duty -O2S	Air Pressure psi (bar)	65 (4)	75 (5)								6,000 (414) (Spring is fully compressed)	.80 to .78***
		Spring Pre-Compression in (mm)	.28 (7)	.38 (10)									
		Stem travel in (mm)	.25 (6)	.25 (6)									
	Extra Heavy Duty Single Stage -HO1S	Air Pressure psi (bar)	50 (3)	60 (4)	70 (5)	80 (6)	90 (6)	100 (7)	100 (7)			15,000 (1034) (Spring is fully compressed)	2.50
		Spring Pre-Compression in (mm)	.38 (10)	.50 (13)	.66 (17)	.81 (21)	.97 (25)	1.13 (29)	1.22 (31)				
		Stem travel in (mm)	.44 (11)	.44 (11)	.44 (11)	.44 (11)	.44 (11)	.44 (11)	.44 (11)	.06 (2)			
	Extra Heavy Duty Two Stage -HO2S	Air Pressure psi (bar)	40 (3)	45 (3)	50 (3)	55 (4)	60 (4)	65 (5)	70 (5)	75 (5)	80 (6)	20,000 (1379)	2.50
		Spring Pre-Compression in (mm)	.19 (5)	.25 (6)	.31 (8)	.41 (10)	.50 (13)	.56 (14)	.66 (17)	.72 (18)	.81 (21)		
		Stem travel in (mm)	.44 (11)	.44 (11)	.44 (11)	.44 (11)	.44 (11)	.44 (11)	.44 (11)	.44 (11)	.44 (11)		
20SM16 10P16	Extra Heavy Duty Single Stage -HO1S	Air Pressure psi (bar)	65 (4)	80 (6)	95 (7)	100 (7)						11,000 (760) (Spring is fully compressed)	2.50
		Spring Pre-Compression in (mm)	.50 (13)	.75 (19)	.97 (25)	1.22 (31)							
		Stem travel in (mm)	.50 (13)	.50 (13)	.50 (13)	.50 (13)							
	Extra Heavy Duty Two Stage -HO2S	Air Pressure psi (bar)	50 (3)	55 (4)	65 (4)	70 (5)	80 (6)	85 (6)	90 (6)	100 (7)	100 (7)	20,000 (1379)	2.50
		Spring Pre-Compression in (mm)	.25 (6)	.38 (10)	.50 (13)	.63 (16)	.75 (19)	.84 (21)	.97 (25)	1.09 (28)	1.22 (31)		
		Stem travel in (mm)	.50 (13)	.50 (13)	.50 (13)	.50 (13)	.50 (13)	.50 (13)	.50 (13)	.50 (13)	.50 (13)		

\* Maximum pressure rating is based on the lowest rating of any components. Actual working pressure may be determined by tubing pressure rating, if lower.

\*\* C<sub>v</sub> data is for 2-way straight valves. For angle pattern add approximately 50% to the C<sub>v</sub> value.

\*\*\* C<sub>v</sub> varies because of spring compression limitations. The flow coefficient range is given for the maximum stem travel (lowest system pressure) to minimum travel (highest system pressure).

CAUTION: While testing has shown O-rings to provide satisfactory service life, both cyclic and shelf life may vary widely with differing service conditions, properties of reactants, pressure and temperature cycling and age of the O-ring, FREQUENT INSPECTIONS SHOULD BE MADE to detect any deterioration, and O-rings replaced as required. All dimensions for reference only and subject to change. For prompt service, Parker Autoclave Engineers stocks select products. Consult your local representative.

# Air Operator Sizing Data

Air To Open (Inlet Pressure Assist may be required on some options)

## Series 30SC/43SC Valves

Valve Series	Operator Duty		System Pressure KSI (bar)											Maximum Pressure psi (bar)*	Flow to 15
			1 to 15 (1035)	16 (1100)	18 (1240)	20 (1380)	22 (1520)	24 (1650)	26 (1790)	28 (1930)	30 (2060)	35 (2410)	40 (2760)		
30SC16	Extra Heavy Duty Two Stage -HO2S	Air Pressure psi (bar)	70 (5)	75 (5)	75 (5)	80 (6)	85 (6)	95 (7)	100 (7)	100 (7)	100 (7)			30,000 (2068)	2.61
		Spring Pre-Compression in (mm)	.56 (14)	.62 (16)	.68 (17)	.75 (19)	.88 (22)	.94 (24)	1.00 (25)	1.06 (27)	1.38 (35)				
		Stem travel in (mm)	.50 (13)	.50 (13)	.50 (13)	.50 (13)	.50 (13)	.50 (13)	.50 (13)	.50 (13)	.50 (13)	.50 (13)			
43SC16 (see note)	Extra Heavy Duty Two Stage -HO2S	Air Pressure psi (bar)	35 (2)	35 (2)	40 (3)	45 (3)	50 (3)	55 (4)	60 (4)	60 (47)	65 (4)	80 (6)	100 (7)	40,000* (2758)	2.61
		Spring Pre-Compression in (mm)	.55 (14)	.55 (14)	.63 (16)	.71 (18)	.79 (20)	.86 (22)	.94 (24)	.94 (24)	1.02 (26)	1.26 (32)	1.38 (35)		
		Stem travel in (mm)	.31 (8)	.31 (8)	.31 (8)	.31 (8)	.31 (8)	.31 (8)	.31 (8)	.31 (8)	.31 (8)	.31 (8)	.31 (8)		

Note: \* Maximum pressure with actuator 40,000 psi use actuators -HO2S.4 (valve orifice .406" diameter)

## Series 30VM Valves

Valve Series	Operator Duty		System Pressure KSI (bar)											Maximum Pressure psi (bar)*	Flow Coefficient**	
			1 to 10 (690)	12 (830)	14 (970)	16 (1100)	18 (1240)	20 (1380)	22 (1520)	24 (1650)	26 (1790)	28 (1930)	30 (2060)			
30VM4	Medium Duty -O1S	Air Pressure psi (bar)	45 (3)	45 (3)	55 (4)	55 (4)	55 (4)	55 (4)	65 (5)	65 (5)	65 (5)	65 (5)	75 (5)	30,000 (2068)	.12	
		Spring Pre-Compression in (mm)	.12 (3)	.12 (3)	.19 (5)	.19 (5)	.19 (5)	.19 (5)	.19 (5)	.25 (6)	.25 (6)	.25 (6)	.25 (6)			.31 (8)
		Stem travel in (mm)	.19 (5)	.19 (5)	.19 (5)	.19 (5)	.19 (5)	.19 (5)	.19 (5)	.19 (5)	.19 (5)	.19 (5)	.19 (5)			.19 (5)
30VM6 and 30VM9	Medium Duty -O1S	Air Pressure psi (bar)	45 (3)	55 (4)	55 (4)	65 (5)	65 (5)	75 (5)	75 (5)	75 (5)	85 (6)	85 (6)	95 (7)	30,000 (2068)	.33 (30VM6)	
		Spring Pre-Compression in (mm)	.12 (3)	.19 (5)	.19 (5)	.25 (6)	.25 (6)	.31 (8)	.31 (8)	.31 (8)	.38 (10)	.38 (10)	.44 (11)			
		Stem travel in (mm)	.19 (5)	.19 (5)	.19 (5)	.19 (5)	.19 (5)	.19 (5)	.19 (5)	.19 (5)	.19 (5)	.19 (5)	.19 (5)			
	Heavy Duty -O2S	Air Pressure psi (bar)	25 (2)	30 (2)	30 (2)	35 (2)	35 (2)	40 (3)	40 (3)	40 (3)	45 (3)	45 (3)	50 (3)		.33 (30VM9)	

# Air Operator Sizing Data

Air To Open (Inlet Pressure Assist may be required on some options)

## Series 40VM Valves

Valve Series	Operator Duty		System Pressure KSI (bar)										Maximum Pressure psi (bar)*	Flow Coefficient**	
			1 to 10 (690)	15 (1030)	20 (1380)	25 (1720)	30 (2070)	35 (2410)	40 (2760)						
40VM9	Medium Duty -O1S	Air Pressure psi (bar)	60 (4)	70 (5)	75 (5)	85 (6)	95 (7)	100 (7)	100 (7)					40,000 (2758)	.28
		Spring Pre-Compression in (mm)	.12 (3)	.18 (5)	.25 (6)	.31 (8)	.38 (10)	.43 (11)	.5 (13)						
	Stem travel in (mm)	.25 (6)	.25 (6)	.25 (6)	.25 (6)	.25 (6)	.25 (6)	.25 (6)							
	Heavy Duty -O2S	Air Pressure psi (bar)	30 (2)	35 (2)	40 (3)	45 (3)	50 (3)	50 (3)	55 (4)						

## Series 60VM Valves

Valve Series	Operator Duty		System Pressure KSI (bar)										Maximum Pressure psi (bar)*	Flow Coefficient**	
			1 to 15 (1030)	20 (1380)	25 (1720)	30 (2070)	35 (2410)	40 (2760)	45 (3100)	50 (3450)	55 (3790)	60 (4140)			
60VM4 and 60VM6	Medium Duty -O1S	Air Pressure psi (bar)	55 (4)	65 (5)	65 (5)	65 (5)	75 (5)	75 (5)	85 (6)	85 (6)	85 (6)	95 (7)		60,000 (2758)	.08 (60VM4)
		Spring Pre-Compression in (mm)	.12 (3)	.19 (5)	.19 (5)	.19 (5)	.25 (6)	.25 (6)	.31 (8)	.31 (8)	.31 (8)	.38 (10)			
	Stem travel in (mm)	.25 (6)	.25 (6)	.25 (6)	.25 (6)	.25 (6)	.25 (6)	.25 (6)	.25 (6)	.25 (6)	.25 (6)	.25 (6)			
	Heavy Duty -O2S	Air Pressure psi (bar)	30 (2)	35 (2)	35 (2)	35 (2)	40 (3)	40 (3)	45 (4)	45 (4)	45 (4)	50 (3)			.09 (60VM6)
60VM9	Medium Duty -O1S	Air Pressure psi (bar)	55 (4)	65 (5)	65 (5)	75 (6)	75 (5)	85 (6)	95 (7)	95 (7)	95 (7)	95 (7)		60,000 (2758)	.14
		Spring Pre-Compression in (mm)	.12 (3)	.19 (5)	.19 (5)	.25 (6)	.25 (6)	.31 (8)	.38 (10)	.38 (10)	.44 (11)	.50 (13)			
	Stem travel in (mm)	.25 (6)	.25 (6)	.25 (6)	.25 (6)	.25 (6)	.25 (6)	.25 (6)	.25 (6)	.19 (5)	.12 (3)				
	Heavy Duty -O2S	Air Pressure psi (bar)	30 (2)	35 (2)	35 (2)	40 (3)	40 (3)	45 (4)	50 (3)	50 (3)	50 (3)	50 (3)			

\* Maximum pressure rating is based on the lowest rating of any components. Actual working pressure may be determined by tubing pressure rating, if lower.

\*\* C<sub>v</sub> data is for 2-way straight valves. For angle pattern add approximately 50% to the C<sub>v</sub> value.

\*\*\* C<sub>v</sub> varies because of spring compression limitations. The flow coefficient range is given for the maximum stem travel (lowest system pressure) to minimum travel (highest system pressure).

CAUTION: While testing has shown O-rings to provide satisfactory service life, both cyclic and shelf life may vary widely with differing service conditions, properties of reactants, pressure and temperature cycling and age of the O-ring. FREQUENT INSPECTIONS SHOULD BE MADE to detect any deterioration, and O-rings replaced as required. All dimensions for reference only and subject to change. For prompt service, Parker Autoclave Engineers stocks select products. Consult your local representative.

# Air Operator Sizing Data

Air To Open (Inlet Pressure Assist may be required on some options)

## Series 100VM and 150V Valves

Valve Series	Operator Duty		System Pressure KSI (bar)										Maximum Pressure psi (bar)*	Flow Coefficient**	
			1 to 20 (1380)	40 (2760)	60 (4140)	80 (5520)	90 (6210)	100 (6900)	125 (8620)	150 (10350)					
100VM4 100VM5 100VM6	Heavy Duty -O2S	Air Pressure psi (bar)	35 (2)	40 (3)	50 (3)	60 (4)	70 (5)	70 (5)						100,000 (6900)	.09 to .07***
		Spring Pre-Compression in (mm)	.12 (3)	.19 (5)	.25 (6)	.31 (8)	.38 (10)	.38 (10)							
		Stem travel in (mm)	.12 (3)	.12 (3)	.12 (3)	.12 (3)	.12 (3)	.12 (3)							
100VM9	Extra Heavy Duty 2 Stage -HO2S	Air Pressure psi (bar)			70 (5)	85 (6)	90 (6)	100 (7)						100,000 (6900)	.65
		Spring Pre-Compression in (mm)			.68 (17)	.90 (23)	1.0 (25)	1.12 (28)							
		Stem travel in (mm)			.44 (11)	.44 (11)	.44 (11)	.44 (11)							
150V5	Heavy Duty -O2S	Air Pressure psi (bar)	30 (2)	40 (3)	45 (3)	55 (4)	60 (4)	60 (4)	70 (5)	75 (5)				150,000 (10350)	.06
		Spring Pre-Compression in (mm)	.12 (3)	.19 (5)	.25 (6)	.31 (8)	.38 (10)	.38 (10)	.44 (11)	.56 (14)					
		Stem travel in (mm)	.12 (3)	.12 (3)	.12 (3)	.12 (3)	.12 (3)	.12 (3)	.12 (3)	.06 (2)					

\* Maximum pressure rating is based on the lowest rating of any components. Actual working pressure may be determined by tubing pressure rating, if lower.

\*\* C<sub>v</sub> data is for 2-way straight valves. For angle pattern add approximately 50% to the C<sub>v</sub> value.

\*\*\* C<sub>v</sub> varies because of spring compression limitations. The flow coefficient range is given for the maximum stem travel (lowest system pressure) to minimum travel (highest system pressure).

CAUTION: While testing has shown O-rings to provide satisfactory service life, both cyclic and shelf life may vary widely with differing service conditions, properties of reactants, pressure and temperature cycling and age of the O-ring, FREQUENT INSPECTIONS SHOULD BE MADE to detect any deterioration, and O-rings replaced as required. All dimensions for reference only and subject to change. For prompt service, Parker Autoclave Engineers stocks select products. Consult your local representative.



# Actuator: Yoke Mounting Dimensions

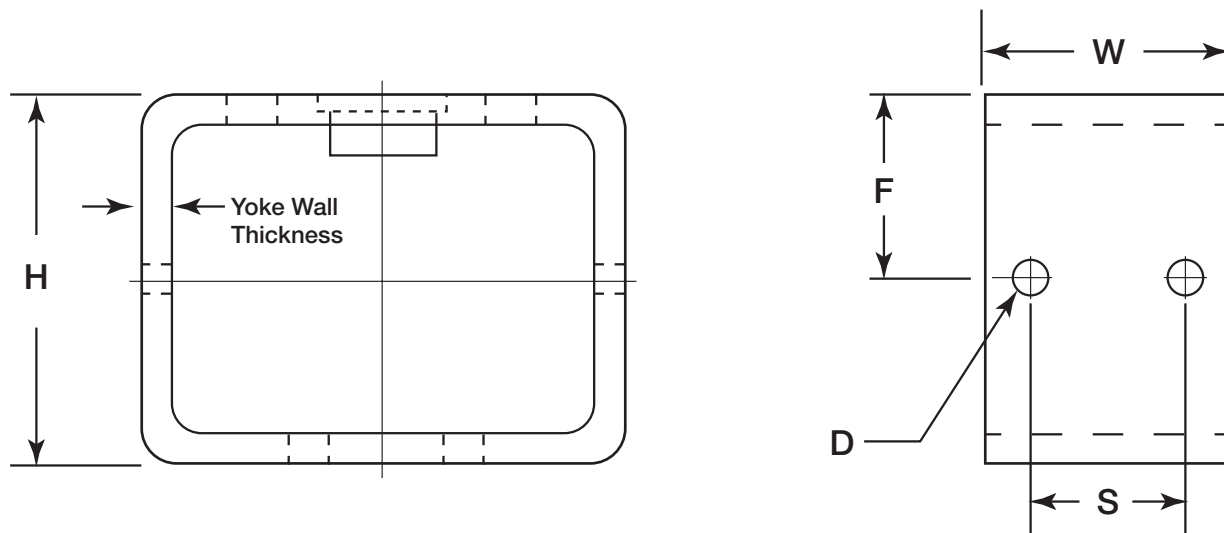

Actuator Group	System Pressure KSI (bar)					
	D (Diameter)	H	W	F	S	Yoke Wall Thickness
<b>O1S, C1S, O2S, C2S</b>						
10V2	.281 (7.1)	3.0 (76)	1.63 (41)	1.50 (38)	1.125 (29)	3/8"
SW4/6, 20SM4/6	.281 (7.1)	3.0 (76)	2.0 (51)	1.50 (38)	1.125 (29)	3/8"
15/20SM9, SW8	.281 (7.1)	3.0 (76)	2.0 (51)	1.50 (38)	1.125 (29)	3/8"
15/20SM12	.281 (7.1)	4.0 (102)	2.13 (54)	1.50 (38)	1.125 (29)	3/8"
20SM16	.281 (7.1)	4.0 (102)	2.13 (54)	1.50 (38)	1.125 (29)	3/8"
30/40/60VM	.281 (7.1)	3.0 (76)	2.0 (51)	1.50 (38)	1.125 (29)	3/8"
100VM4/6	.281 (7.1)	3.0 (76)	2.0 (51)	1.50 (38)	1.125 (29)	3/8"
<b>HO1S, HC1S, HO2S, HC2S</b>						
20SM9/12/16	.516 (13.1)	3.94 (100)	3.0 (76)	1.97 (50)	1.50 (38)	1/2"
15SM16/24	.516 (13.1)	3.94 (100)	3.0 (76)	1.97 (50)	1.50 (38)	1/2"
30/43SC	.516 (13.1)	3.94 (100)	3.0 (76)	1.97 (50)	1.50 (38)	1/2"
100VM9	.516 (13.1)	3.94 (100)	3.0 (76)	1.97 (50)	1.50 (38)	1/2"
<b>OLP/CLP</b>						
10V2	.219 (5.6)	2.5 (64)	1.0 (25)	1.25 (32)	.562 (14)	3/16"



# Parker's Motion & Control Technologies

At Parker, we're guided by a relentless drive to help our customers become more productive and achieve higher levels of profitability by engineering the best systems for their requirements. It means looking at customer applications from many angles to find new ways to create value. Whatever the motion and control technology need, Parker has the experience, breadth of product and global reach to consistently deliver. No company knows more about motion and control technology than Parker. For further information call 1-800-C-Parker.

MARKET	KEY MARKETS	KEY PRODUCTS		
 <b>AEROSPACE</b>	Aircraft Engines Commercial Commerical Transports Military Aircraft Regional Transports	Business and General Aviation Land-Based Weapons Systems Missiles and Launch Vehicles Unmanned Aerial Vehicles	Flight Control Systems & Components Fluid Conveyance Systems Fluid Metering Delivery & Atomization Devices Fuel Systems & Components	Hydraulic Systems & Components Inert Nitrogen Generating Systems Pneumatic Systems & Components Wheels & Brakes
 <b>CLIMATE CONTROL</b>	Agriculture Food, Beverage and Dairy Precision Cooling Transportation	Air Conditioning Life Sciences & Medical Processing	Co2 Controls Electronic Controllers Filter Driers Hand Shut-Off Valves Hose & Fittings	Pressure Regulating Valves Refrigerant Distributors Safety Relief Valves Solenoid Valves Thermostatic Expansion Valves
 <b>ELECTRO-MECHANICAL</b>	Aerospace Life Science & Medical Packaging Machinery Plastics Machinery & Converting Semiconductor & Electronics Factory Automation	Machine Tools Paper Machinery Primary Metals Textile Wire & Cable	AC/DC Drives & Systems Electric Actuators, Gantry Robots & Slides Electrohydrostatic Actuation Systems Electromechanical Actuation Systems Human Machine Interface	Linear Motors Stepper Motors, Servo Motors Drives & Controls Structural Extrusions
 <b>FILTRATION</b>	Food & Beverage Life Sciences Mobile Equipment Power Generation Transportation	Industrial Machinery Marine Oil & Gas Process	Analytical Gas Generators Compressed Air & Gas Filters Condition Monitoring Engine Air, Fuel & Oil Filtration & Systems	Hydraulic, Lubrication & Coolant Filters Process, Chemical, Water Microfiltration Filters Nitrogen, Hydrogen & Zero Air Generators
 <b>FLUID and GAS HANDLING</b>	Aerospace Agriculture Bulk Chemical Handling Construction Machinery Food & Beverage Fuel & Gas Delivery	Industrial Machinery Mobile Oil & Gas Transportation Welding	Brass Fittings & Valves Diagnostic Equipment Fluid Conveyance Systems Industrial Hose	PTFE & PFA Hose, Tubing & Plastic Fittings Rubber & Thermoplastic Hose & Couplings Tube Fittings & Adapters Quick Disconnects
 <b>HYDRAULICS</b>	Aerospace Aerial lift Agriculture Construction Machinery Forestry	Industrial Machinery Mining Oil & Gas Power Generation & Energy Truck Hydraulics	Diagnostic Equipment Hydraulic Cylinders & Accumulators Hydraulic Motors & Pumps Hydraulic Systems Hydraulic Valves & Controls	Power Take-Offs Rubber & Thermoplastic Hose & Couplings Tube Fittings & Adapters Quick Disconnects
 <b>PNEUMATICS</b>	Aerospace Conveyor & Material Handling Factory Automation Life Science & Medical	Machine Tools Packaging Machinery Transportation & Automotive	Air Preparation Brass Fittings & Valves Manifolds Pneumatic Accessories Pneumatic Actuators & Grippers Pneumatic Valves & Controls	Quick Disconnects Rotary Actuators Rubber & Thermoplastic Hose & Couplings Structural Extrusions Thermoplastic Tubing & Fittings Vacuum Generators, Cups & Sensors
 <b>PROCESS CONTROL</b>	Chemical & Refining Food, Beverage & Dairy Medical & Dental	Microelectronics Oil & Gas Power Generation	Analytical Sample Conditioning Products & Systems Fluoropolymer Chemical Delivery Fittings, Valves & Pumps High Purity Gas Delivery Fittings, & Valves & Regulators	Instrumentation Fittings, Valves Regulators Medium Pressure Fittings & Valves Process Control Manifolds
 <b>SEALING and SHIELDING</b>	Aerospace Chemical Processing Consumer Energy, Oil & Gas Fluid Power General Industrial	Information Technology Life Sciences Military Semiconductor Transportation	Dynamic Seals Elastomeric O-Rings Emi Shielding Extruded & Precision-Cut, Fabricated Elastomeric Seals	Homogeneous & Inserted Elastomeric Shapes High Temperature Metal Seals Metal & Plastic Retained Composite Seals Thermal Management

# Parker Worldwide

## North America

**USA** – Corporate, Cleveland, OH  
Tel: +1 256 896 3000

**USA** – IPD, Huntsville, AL  
Tel: +1 256 881 2040  
ipdcct@parker.com

**USA** – IPD, (Autoclave), Erie, PA  
Tel: +1 814 860 5700  
ipdaect@parker.com

**CA** – Canada, Grimsby, Ontario  
Tel: +1 905-945-2274  
ipd\_canada@parker.com

## South America

**AR** – Argentina, Buenos Aires  
Tel: +54 3327 44 4129  
falecom@parker.com

**BR** – Brazil, Diadema, SP  
Tel: +55 11 4360 6700  
falecom@parker.com

**CL** – Chile, Santiago  
Tel: +56 (0) 2 2303 9640  
falecom@parker.com

**MX** – Mexico, Toluca  
Tel: +52 722 275 4200  
contacto@parker.com

## Asia Pacific

**AU** – Australia, Dandenong  
Tel: +61 (0)2 9842 5150  
customer.service.au@parker.com

**CN** – China, Shanghai  
Tel: +86 21 2899 5000  
INGtechnical.china@parker.com

**HK** – Hong Kong  
Tel: +852 2428 8008

**IN** – India, Mumbai  
Tel: +91 22 6513 7081-85

**ID** – Indonesia, Tangerang  
Tel: +62 2977 7900  
parker.id@parker.com

**JP** – Japan, Tokyo  
Tel: +(81) 3 6365 4020  
infophj@parker.com

**KR** – South Korea, Seoul  
Tel: +82 2 559 0400  
parkerkr@parker.com

**MY** – Malaysia, Selangor  
Tel: +603 784 90 800  
parkermy@parker.com

**SG** – Singapore,  
Tel: +65 6887 6300  
parkerkg@parker.com

**TH** – Thailand, Bangkok  
Tel: +66 2 186 7000  
phthailand@parker.com

**TW** – Taiwan, Taipei  
Tel: +886 2 2298 8987  
enquiry.taiwan@parker.com

**VN** – Vietnam, Hanoi  
Tel: +848 382 508 56  
parker\_viet@parker.com

## Europe, Middle East, Africa

**AE** – UAE, Dubai  
Tel: +971 4 812 7100  
parker.me@parker.com

**AT** – Austria, Wiener Neustadt  
Tel: +43 (0)2622 23501-0  
parker.austria@parker.com

**AT** – Eastern Europe, Wiener Neustadt  
Tel: +43 (0)2622 23501 900  
parker.easteurope@parker.com

**AZ** – Azerbaijan, Baku  
Tel: +994 50 2233 458  
parker.azerbaijan@parker.com

**BE/LU** – Belgium, Nivelles  
Tel: +32 (0)67 280 900  
parker.belgium@parker.com

**BG** – Bulgaria, Sofia  
Tel: +359 2 980 1344  
parker.bulgaria@parker.com

**BY** – Belarus, Minsk  
Tel: +48 (0)22 573 24 00  
parker.belarus@parker.com

**CH** – Switzerland, Etoy  
Tel: +41 (0) 21 821 87 00  
parker.switzerland@parker.com

**CZ** – Czech Republic, Klecany  
Tel: +420 284 083 111  
parker.czechrepublic@parker.com

**DE** – Germany, Kaarst  
Tel: +49 (0)2131 4016 0  
parker.germany@parker.com

**DK** – Denmark, Ballerup  
Tel: +45 43 56 04 00  
parker.denmark@parker.com

**ES** – Spain, Madrid  
Tel: +34 902 33 00 01  
parker.spain@parker.com

**FI** – Finland, Vantaa  
Tel: +358 (0)20 753 2500  
parker.finland@parker.com

**FR** – France, Contamine s/Arve  
Tel: +33 (0)4 50 25 80 25  
parker.france@parker.com

**GR** – Greece, Athens  
Tel: +30 210 933 6450  
parker.greece@parker.com

**HU** – Hungary, Budapest  
Tel: +36 223 885 470  
parker.hungary@parker.com

**IE** – Ireland, Dublin  
Tel: +353 (0)1 466 6370  
parker.ireland@parker.com

**IT** – Italy, Corsico (MI)  
Tel: +39 02 45 19 21  
parker.italy@parker.com

**KZ** – Kazakhstan, Almaty  
Tel: +7 7273 561 000  
parker.easteurope@parker.com

**NL** – The Netherlands, Oldenzaal  
Tel: +31 (0)541 585 000  
parker.nl@parker.com

**NO** – Norway, Stavanger  
Tel: +47 66 75 34 00  
parker.norway@parker.com

**PL** – Poland, Warsaw  
Tel: +48 (0)22 573 24 00  
parker.poland@parker.com

**PT** – Portugal, Leca da Palmeira  
Tel: +351 22 999 7360  
parker.portugal@parker.com

**RO** – Romania, Bucharest  
Tel: +40 21 252 1382  
parker.romania@parker.com

**RU** – Russia, Moscow  
Tel: +7 495 645-2156  
parker.russia@parker.com

**SE** – Sweden, Spånga  
Tel: +46 (0)8 59 79 50 00  
parker.sweden@parker.com

**SK** – Slovakia, Banská Bystrica  
Tel: +421 484 162 252  
parker.slovakia@parker.com

**SL** – Slovenia, Novo Mesto  
Tel: +386 7 337 6650  
parker.slovenia@parker.com

**TR** – Turkey, Istanbul  
Tel: +90 216 4997081  
parker.turkey@parker.com

**UA** – Ukraine, Kiev  
Tel: +48 (0)22 573 24 00  
parker.ukraine@parker.com

**UK** – United Kingdom, Warwick  
Tel: +44 (0)1926 317 878  
parker.uk@parker.com

**ZA** – South Africa, Kempton Park  
Tel: +27 (0)11 961 0700  
parker.southafrica@parker.com

### ! CAUTION !

Do not mix or interchange component parts or tubing with those of other manufacturers. Doing so is unsafe and will void warranty.

Parker Autoclave Engineers Valves, Fittings, and Tools are not designed to interface with common commercial instrument tubing and are designed to only connect with tubing manufactured to Parker Autoclave Engineers AES specifications. Failure to do so is unsafe and will void warranty.

### WARNING

**FAILURE, IMPROPER SELECTION OR IMPROPER USE OF THE PRODUCTS AND/OR SYSTEMS DESCRIBED HEREIN OR RELATED ITEMS CAN CAUSE DEATH, PERSONAL INJURY AND PROPERTY DAMAGE.**

This document and other information from Parker Hannifin Corporation, its subsidiaries and authorized distributors provide product and/or system options for further investigation by users having technical expertise. It is important that you analyze all aspects of your application and review the information concerning the product or system in the current product catalog. Due to the variety of operating conditions and applications for these products or systems, the user, through its own analysis and testing, is solely responsible for making the final selection of the products and systems and assuring that all performance, safety and warning requirements of the application are met. The products described herein, including without limitation, product features, specifications, designs, availability and pricing, are subject to change by Parker Hannifin Corporation and its subsidiaries at any time without notice.

### Offer of Sale

The items described in this document are available for sale by Parker Hannifin Corporation, its subsidiaries or its authorized distributors. Any sale contract entered by Parker will be governed by the provisions stated in Parker's standard terms and conditions of sale (copy available upon request).



**Instrumentation Products Division**  
Autoclave Engineers Operation  
8325 Hessinger Drive  
Erie, PA 16509-4679  
Tel: 814 860 5700  
Fax: 814 860 5811  
[www.autoclave.com](http://www.autoclave.com)  
[www.parker.com/ipd](http://www.parker.com/ipd)

**Instrumentation Products Division**  
Division Headquarters  
1005 A Cleaner Way  
Huntsville, AL 35805 USA  
Tel: 256 881 2040  
Fax: 256 881 5072

**Parker Hannifin Manufacturing Ltd.**  
Instrumentation Products Division,  
Europe  
Riverside Road  
Pottington Business Park  
Barnstaple, UK, EX31 1NP, UK  
Tel: 44 1271 313131  
Fax: 44 1271 373636