



# AIR TREATMENT

## CHAPTER 3













General informations

Air treatment of the pneumatic plants

page 3.1.1



Modular units

page 3.2.1

Series		Type	Page
Filters		A..F	3.2.20
Mist separators		A..FD	3.2.30
Regulators		A..R	3.2.50
Precision regulators		A..RP	3.2.60
Lubricators		A..L	3.2.80
Lubricators with large capacity cup		A..LG	3.2.90
Filter-regulators		A..FRR	3.2.110
Filter-regulators+lubricators		A..FRRL	3.2.140
Soft-start solenoid operated valves		AVP..E	3.2.200
Soft-start air operated valves		AVP..P	3.2.210
Exhaust manual operated valves		VMS	3.2.250

F-R-L units 1-1/2" and 2"

page 3.6.1

Series		Type	Page
Filters		A..F	3.6.20
Regulators		A..R	3.6.50
Lubricators		A..L	3.6.80



Microregulators

Series		Type	Page
Microregulators		AC700	3.10.1

Pressure-gauges, vacuum-gauges and pressure switches page 3.30.1

Series		Type	Page
Analogic pressure-gauges		M, MR, MF, MP	3.30.20
Digital pressure-gauges		AKP60P	3.30.40
Digital vacuum-gauges		AKP60V	3.30.40
Digital pressure switches		AKP43	3.30.60

End-of-line components page 3.40.1

Series		Type	Page
Automatic condense drains		A..FLSA	3.40.10
Silenced exhaust filters		A..FLFS	3.40.30

Mounting accessories

Series		Type	Page
Spacers for modular components		D, DT, DSL, SL, DST, ST	3.90.1
Mounting brackets for modular units and microregulators		SR, SRP, SFL	3.90.1
Mounting brackets and adapters for digital pressure-gauges, vacuum-gauges and pressure switches		ABT, AKP, APAC, APAD	3.90.1



### Compressed air treatment

The air destined for use in pneumatic devices must be suitably prepared.  
It is taken from the surrounding environment for introduction into the compressor and is rich in impurities and water vapour.  
The compressor itself inevitably releases lubricating oil into the air, which is very dangerous for the seals of the pneumatic components.  
Following passage through the compressor, the compressed air is always stored in a large tank that has a dual function: to even out oscillations in pressure and to cool the compressed air.  
Indeed, the high temperatures reached at the end of the compression process aid the evaporation of the water in the air against the condensing effect of the high pressures.  
For these reasons, the tank located downstream of the compressor must be of a suitable size: in particular, in the case in which the compressor is volumetric and a high quantity of air is taken up.  
It is very important that the compressed air has time to cool, allowing the water vapour contained in it to condense on the bottom of the tank, as it is considerably more convenient to eliminate as much of the water vapour as possible during this stage.  
Even with these precautions, the percentage of humidity present in the compressed air remains important. Indeed, during distribution along the pipes, further condensation occurs, due to the further cooling of the air and despite the falls in pressure that aid the dissolution of the water. For this reason the distribution pipes must be slightly inclined (~2%) and feature umbrella-handle pipes at regular intervals that lead to small condensation collection tanks.  
Particular attention must be paid to the lubricating oil, especially in the case of centrifugal compressors: it must be eliminated by means of appropriate oil extraction filters at the exit of the compressor.  
The humidity of the air causes rust and corrosion in the metal pipes, deposits in the pneumatic devices and the formation of sleeves of ice at the discharge points in particular atmospheric conditions and for high-frequency use.

### Safety in pneumatic systems

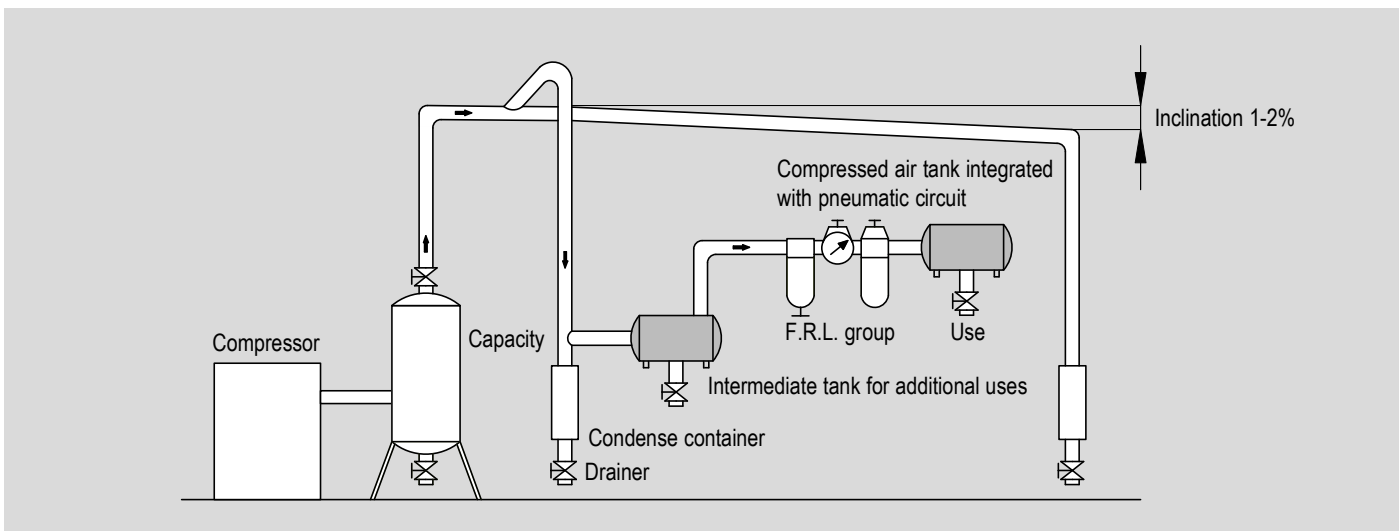

The operating safety and lifespan of the pneumatic devices depend to a considerable degree upon the proper preparation of the compressed air that feeds them, which is obtained by means of a series of devices that are located upstream of the part of the apparatus described so far, but before the actual pneumatic system.

### Devices for compressed air treatment

Compressed air treatment equipment basically consists of: filters, pressure regulators, lubricators;  
Also part of them, by extension, are: pressure-gauges, soft-start valves, insertion and sectioning valves, air reservoirs.

Filters

The impurities contained in the air: waste materials, powder, rust and humidity that condenses, can cause serious damage to the pneumatic components, compromising their functioning and duration, as they facilitate the wear of the flowing surfaces and the seals.

The filter have the important function of purifying the compressed air of solid particles and, as a collateral effect associated with their operating characteristics, also of a percentage of the liquid ones.

The filters are constituted by: a body with threaded ports, a transparent cup screwed onto it and a filtering cartridge.

The compressed air to be filtered is conveyed in a tangential direction from the supply mouth to the cup, where it assumes a cyclonic movement which enables the separation of the larger solid particles and a good part of the liquid particles; both collect on the bottom of the cup, from where they are discharged on a regular basis.

The finer solid particles, on the other hand, are captured by the filtering cartridge, which is made from sintered material (bronze, ceramic material& ). Depending on its characteristics, the filtering cartridge captures solid particles of an average diameter of 40, 20 or 5 micron.

It is not possible in any case to restrain the liquid particles that do not collect on the bottom of the cup as they are drawn and pass the barrier.

Consequently the effect of separation of the condensation, which is introduced by the filter, is a secondary one; it is necessary to take care to discharge the condensation that is produced otherwise a dynamic equilibrium is produced in which as much condensation is removed as is produced.

The filters are normally equipped with a separator, beneath the cartridge, whose task is to keep the slimy liquid deposited still; levels above the separator must be discharged.

It is always advisable to choose a larger size filter in order to have the benefits of a large cup, considerable cooling of the air and good separation of the impurities.

It is not in any case possible to hold back sufficient liquid particles to achieve the effective extraction of oil from the air: it is just a matter of time before the oil, which is not filtered upstream, reaches the pneumatic components. A considerable percentage of humidity will also always be present in the air downstream of the filter. In order to eliminate the oil of the air compressor, it is necessary to adopt special oil extraction filters.

The choice of the cartridge depends on the degree of cleanliness necessary for the air to be used in the system.

The more complex the system, with small and fast-moving components, the greater must be the degree of filtration of the cartridge.

The ideal filter is a component that does not introduce falls in pressure. Actually, a fall of pressure always exists around a filter and depends largely on the degree of filtration.

It is advisable to limit the fall of pressure to 0.2 ÷ 0.3 bar, as the production costs of compressed air are very high and, if it is wished to maintain the supply pressure of the components constant, each fall in pressure translates into greater pressure to be generated by the compressor.

The filtering cartridge gets dirty very easily: if cleaning is neglected the flow of air across the filter can be greatly reduced; furthermore, in order to minimize falls in pressure, it is wise to clean it frequently, removing the grease from it and drying it.

Choosing size of filters

It is necessary to adapt the filters to the flow required by the system, or section of the system, which they feed.

The characteristic "fall in pressure - flow" curves of the filter are used for this purpose. They associate the variation in the falls in pressure around the filter with the variation of the flow and indicate the range of use (useful flow interval) of the component in an immediately comprehensible manner.

The range of use increases with the increase in the dimensions of the filter (of its ports).

It is advisable to choose a filter of such dimensions that, at the requested flow, the fall in pressure is maintained within the limits indicated above. In this case the filter also works well for the separation of the condensation.

An under-sized filter causes excessive falls in pressure, whilst the filtering effect is poor.

Normally a filter capable of providing the required flow, without high filtering capacities, but suitable for the supply of compressed air to the valves and pneumatic cylinders, is installed at the beginning of a system. Filters that provide better quality air are installed downstream of the derived devices - with a lower flow - that require it.

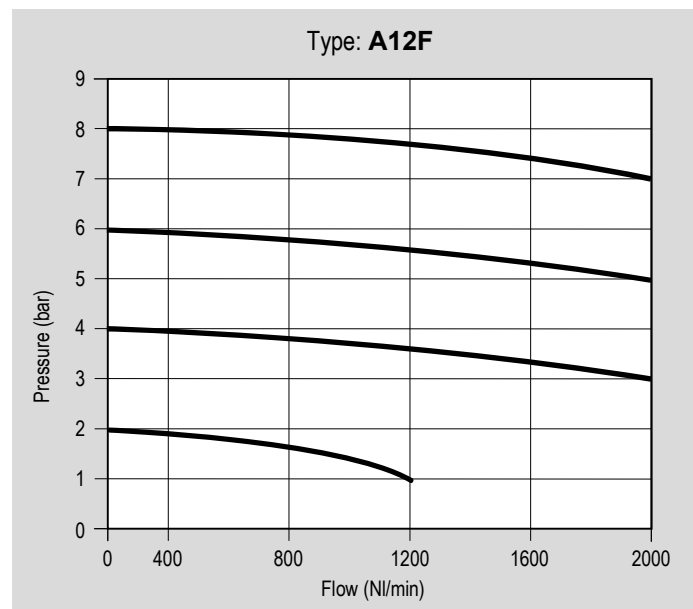

Pressure regulators

Pressure adjustment is always necessary upstream of a pneumatic device: it prevents falls of pressure in the network from distorting the conditions of use.

The performance of valves and pneumatic cylinders are highly dependant on the value of the supply pressure. Some components require precise and constant pressures in order to work properly.

A pressure regulator is always installed upstream of the system, and its task is to maintain the operating pressure at the output opening constant with the variation of the flow and the constant pressure in the tank.

Rapid and considerable variations in flow, corresponding to consumption peaks, tend to cause falls in pressure that can be controlled by the use of suitably sized reserve tanks.

The reduced operating pressure is less than the output pressure of the compressor; both must be appropriately controlled. Indeed, whilst it is true that lower material costs and, at an equivalent power, lower flows of used air would be incurred by making the pneumatic components function at high pressure, it is equally true that the production costs of compressed air are very high and increase considerably with the increase in the value of the pressure at which the air is supplied.

If the thermodynamic efficiency of the compressor - which is notoriously bad and decreases with the increase in the final pressure - is multiplied by the bad conversion efficiency of mechanical energy into pressure energy, a very low final efficiency figure is obtained that justifies the high production costs of compressed air.

In addition, it is necessary to consider the fact that it is, in practice, impossible to eliminate the losses of compressed air, which increase proportionately with the pressure.

On average, a system can lose up 20% of its compressed air through bad connections in correspondence with fittings and plugs.

In the presence of two cost causes, one increasing and the other decreasing in relation to the pressure, it is possible to identify a pressure value that corresponds to the minimum cost.

The optimum operating pressure has long been established as 6 bar. The pressure in the tank must be that much higher in order to guarantee its cooling and energy flywheel functions.

Pressure regulators are basically constituted by:

- a body, divided into a bell (with hand-wheel for adjustments and spring) and an actual valve body (with obturator disc) equipped with threaded openings.
- a diaphragm between the two parts.

The air that arrives from the supply port is blocked (or allowed to pass) by an obturator disc which is opened and closed by means of a small rod controlled by the diaphragm in equilibrium between the two forces: one, above, (caused by a charged spring or a pressure) that is preset; the other, below, caused by the reduced pressure in the pipe downstream of the regulator.

Each variation in flow causes a temporary variation of the reduced pressure and thus an imbalance in these two forces that causes the movement of the diaphragm with the consequent opening or closure of the disc.

A reduction in flow causes the following temporary effects: an increase in the reduced pressure with the closure of the disc; an increase in the pressure fall, due to the reduction of the passage space and a decrease in the reduced pressure, with oscillations around the point of equilibrium, until it returns the previous value, which is the only one capable of balancing the preset force.

An increase in flow causes: a decrease in the reduced pressure; the opening of the disc; a decrease in the pressure fall, due to the increased passage space and an increase in the reduced pressure until it returns to the previous value.

In both cases the pressure regulator restores the conditions of equilibrium with a new position of the obturator disc, which is suited to the changed flow demand.

In the case of constant supply pressure and highly variable flows, the pressure regulators are self-adjusting; i.e. they maintain the reduced pressure basically constant.

The greater the dimensions of the diaphragm, the greater the sensitivity of the reducer and its ability to maintain the reduced pressure constant.

Choosing size of pressure regulators

The characteristic "fall in reduced pressure - flow" curves are used for this purpose as they provide the range of use of the component in an immediately comprehensible manner.

It is always advisable to choose a regulator capable of supplying the flow of air required by the system, upstream of which it is installed, with as low a possible fall in reduced pressure: max. 0.5 bar.

The range of use of the regulator is associated with the dimensions of the ports used (standardized) and thus to the dimensions of the regulator. In order to achieve sensitivity, speed of response and small falls, it is necessary to choose large bodies with large diaphragms.

Two basic types of regulators can be identified:

- precision regulators, with large diaphragms
- commercial regulators, where the aesthetic aspect is important.

In order to achieve the most precise and easiest setting of the pressure, various ranges of reduced pressure are supplied for each type of regulator, by equipping them with pre-charging springs with different elastic constants.

Another significant construction characteristic for the choice of a regulator is the presence of a device that enables excess pressure in relation to the preset reduced value to be discharged into the atmosphere; in the absence of flow, this is achieved by simply varying the charge of the spring.

This process, known as relieving, consists in equipping the diaphragm with a hole with a seal upon which the controlled rod rests. As the disc reaches the end of its stroke against the closure opening, each further increase in pressure raises the diaphragm above the rod, releasing the air from a hole in the bell until equilibrium is restored.

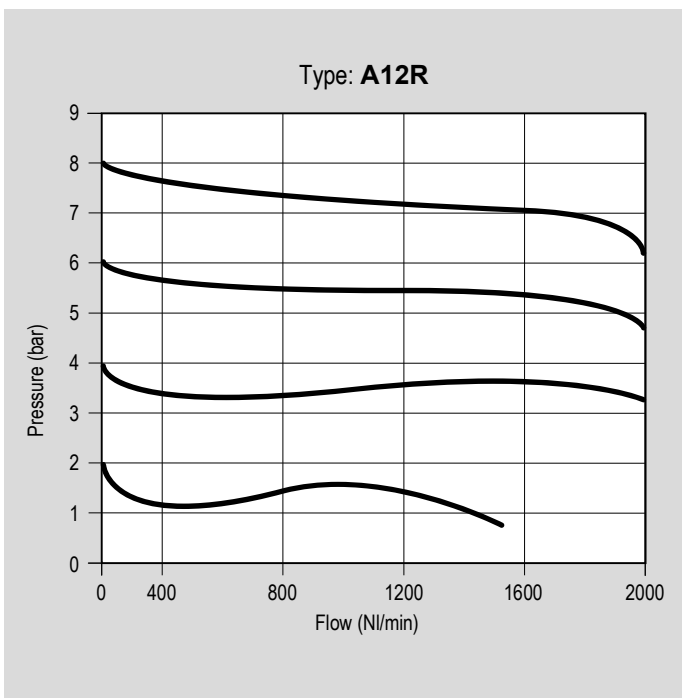

### Lubricators

The pneumatic devices are equipped with mechanical organs with relative movement and consequently require lubrication, which is also important in order to limit wear of the seals.

Valves and pneumatic cylinders are currently supplied with assembly lubrication, which is capable of ensuring them a long life in normal working conditions.

Lubrication is necessary in the case of pneumatic tools and particular working conditions (e.g. components that operate at high speeds or in the presence of high temperatures, which are conditions that cause the assembly lubrication to evaporate and be removed by the air).

Lubrication is performed by lubricating the air that flows through the components with mineral oil that does not contain additives that could corrode the seals.

The task of the lubricators is to dose the air with a certain quantity of nebulized oil.

The air itself transports the oil along stretches of piping, the length of which increases as the size of the drops of the micro-mist decrease.

The lubricators are made up of:

- a body with threaded ports, containing a Venturi connected by means of a small tube
- a cup, to be screwed onto the body, into which the lubricating oil is poured.

The air, entering from the supply opening, crosses the Venturi constriction, where it creates a reduction in pressure that draws the oil from the cup through the small tube, nebulizing it and sending into the pipes.

An adjustment screw makes it possible to regulate the quantity of oil introduced.

There is a minimum operating flow, characteristic of each range of lubricators, beneath which a sufficient fall in pressure is not achieved in the constriction and consequently the oil is not drawn.

### Choosing size of lubricators

The characteristic "fall in pressure - flow" curves are used for this purpose as they permit the rapid identification of the range of use.

It is advisable to choose the lubricator in such a way as to limit the falls of pressure.

The flows provided are, as always, associated with the dimensions and thus to the ports of the lubricator.



# MODULAR

units



Find out our  
key products



**Solution for most applications**



**Easy and intuitive choice**



**Excellent value for money**



**Wide availability**



**Fast delivery**



## Main features and certifications

Aluminium modular air treatment units.  
Supplied as standard in compliance to Reach and RoHS directives, and SIL certified.



### Filters series A..F, 1/4" ÷ 1"

from page 3.2.20



Aluminium modular filters, available in sizes 1/4", 3/8", 1/2" and 1". Equipped with 25µm filtering element and semi-automatic condensate drain. The polycarbonate cup is with metal protection.  
Mounting brackets to be ordered separately.  
Spare parts available for filter cartridge, cup and cup seals.



### Mist separators series A..FD, 3/8" ÷ 1"

from page 3.2.30



Aluminium modular mist separators, available in sizes 3/8", 1/2" and 1". Equipped with 0.3µm filtering element and semi-automatic condensate drain. The polycarbonate cup is with metal protection.  
Mounting brackets to be ordered separately.  
Spare parts available for filter cartridge, cup and cup seals.



### Regulators series A..R, 1/4" ÷ 1"

from page 3.2.50



Aluminium modular regulators, available in sizes 1/4", 3/8", 1/2" and 1". Equipped with relieving valve and practical plastic regulation knob with position lock.  
Pressure-gauges and mounting brackets to be ordered separately.  
Spare parts available for regulator diaphragm.



### Precision regulators series A..RP, 1/8" ÷ 1/2"

from page 3.2.60



Aluminium modular precision regulators, available in sizes 1/8", 1/4" and 1/2". Equipped with relieving valve (also with threaded exhaust for size 1/2" only) and practical plastic regulation knob. Three different pressure regulation ranges available. Pressure-gauges and mounting brackets to be ordered separately.

Note:

Size 1/8" can be mounted in combination with modular component size 1/4" only.

Size 1/4" can be mounted in combination with modular component size 3/8" only.

Size 1/2" can be mounted in combination with modular component size 1/2" only.



### Lubricators series A..L, 1/4" ÷ 1"

from page 3.2.80



Aluminium modular lubricators, available in sizes 1/4", 3/8", 1/2" and 1". Equipped with oil regulation cup, and polycarbonate cup with metal protection.  
The lubricant can be added without stopping the air supply.  
Mounting brackets to be ordered separately.  
Spare parts available for oil regulation cup, cup and cup seals.



Lubricators with large capacity cup series A..LG, 1/4" from page 3.2.90



Aluminium modular lubricators with large capacity cup, available in size 1/4" only. Equipped with oil regulation cup and wide visibility polycarbonate cup. The lubricant can be added without stopping the air supply. Mounting brackets to be ordered separately.



Filter-regulators series A..FRR, 1/4" ÷ 1" from page 3.2.110



Aluminium modular filter-regulators, available in sizes 1/4", 3/8", 1/2" and 1". Equipped with 25µm filtering element, semi-automatic condensate drain, relieving valve and plastic handy regulation knob with position lock. The polycarbonate cup is with metal protection. Pressure-gauges and mounting brackets to be ordered separately. Spare parts available for regulator diaphragm, filter cartridge, cup and cup seals.



Filter-regulators + lubricators series A..FRRL, 1/4" ÷ 1" from page 3.2.140



Aluminium modular filter-regulators with lubricator, available in sizes 1/4", 3/8", 1/2" and 1". Equipped with 25µm filtering element, semi-automatic condensate drain, relieving valve, oil regulation cup and plastic handy regulation knob with position lock. The polycarbonate cups are with metal protection. The lubricant can be added without stopping the air supply. Supplied assembled with "T" type bracket. Pressure-gauges and further mounting brackets to be ordered separately. Spare parts available for regulator diaphragm, oil regulation cup, filter cartridge, cup and cup seals.

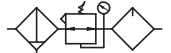

Soft-start solenoid operated valves series AVP..E, 1/4" ÷ 1/2" from page 3.2.200



Aluminium modular soft-start solenoid operated valves, available in sizes 1/4", 3/8" and 1/2", allow the gradual pressurization of pneumatic systems at startup. Ideal as emergency sectioning valves, with rapid downstream line exhaust. These valves ensure low consumption, are equipped with manual override and exhaust function. Coils, connectors, pressure-gauges and mounting brackets to be ordered separately.

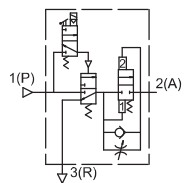

Soft-start air operated valves series AVP..P, 1/4" ÷ 1/2" from page 3.2.210



Aluminium modular soft-start air operated valves, available in sizes 1/4", 3/8" and 1/2", allow the gradual pressurization of pneumatic systems at startup. Ideal as emergency sectioning valves, with rapid downstream line exhaust. These valves ensure low consumption and are equipped with exhaust function. Pressure-gauges and mounting brackets to be ordered separately.

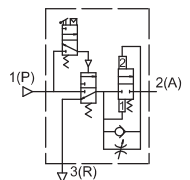

Exhaust manual operated valves series VMS, 1/4" ÷ 1" from page 3.2.250



Aluminium modular exhaust manual operated 3 way valves, available in sizes 1/4", 3/8", 1/2" and 1", allow manual exhaust of residual air from the system. Padlock applicable to the operating knob to prevent unauthorized use. Mounting brackets to be ordered separately.



## Options

Description	Symbol	Suffix
Filter cartridge 5 µm		<b>5</b>
Automatic condense drain for filter (only for sizes 3/8" - 1/2" - 1")		<b>SA</b>
Metal cup		<b>TM</b>
Regulation range 0,5 ÷ 4 bar		<b>04</b>
NPT thread		<b>NPT</b>

The options, when this is possible, can be combined with each other. For options matching see table on the next page; For code key see from page 3.2.6

Options matching

Type	Size	Model	Standard options matching				
			5	SA	TM	04	NPT
A..F	1/4"	Standard	●	-	●	-	●
		Metal cup (TM)	●	-		-	●
	3/8"-1/2"-1"	Standard	●	●	●	-	●
		Automatic condense drain (SA)	●		●	-	●
		Metal cup (TM)	●	●		-	●
A..FD	3/8"-1/2"-1"	Standard	-	●	●	-	●
		Automatic condense drain (SA)	-		●	-	●
		Metal cup (TM)	-	●		-	●
A..R	1/4"	Standard	-	-	-	●	●
		Regulation range 0,5 ÷ 4 bar (04)	-	-	-		●
	3/8"-1/2"-1"	Standard	-	-	-	●	●
		Regulation range 0,5 ÷ 4 bar (04)	-	-	-		●
A..RP	1/8"-1/4"-1/2"	Standard	-	-	-	-	●
A..L	1/4"	Standard	-	-	●	-	●
		Metal cup (TM)	-	-		-	●
	3/8"-1/2"-1"	Standard	-	-	●	-	●
		Metal cup (TM)	-	-		-	●
A..LG	1/4"	Standard	-	-	-	-	●
A..FRR	1/4"	Standard	●	-	●	●	●
		Metal cup (TM)	●	-		●	●
		Regulation range 0,5 ÷ 4 bar (04)	●	-	●		●
	3/8"-1/2"-1"	Standard	●	●	●	●	●
		Automatic condense drain (SA)	●		●	●	●
		Metal cup (TM)	●	●		●	●
		Regulation range 0,5 ÷ 4 bar (04)	●	●	●		●
A..FRRL	1/4"	Standard	●	-	●	●	●
		Metal cup (TM)	●	-		●	●
		Regulation range 0,5 ÷ 4 bar (04)	●	-	●		●
	3/8"-1/2"-1"	Standard	●	●	●	●	●
		Automatic condense drain (SA)	●		●	●	●
		Metal cup (TM)	●	●		●	●
		Regulation range 0,5 ÷ 4 bar (04)	●	●	●		●
AVP..E	1/4"-3/8"-1/2"	Standard	-	-	-	-	●
AVP..P	1/4"-3/8"-1/2"	Standard	-	-	-	-	●
VMS	1/4"-3/8"-1/2"-1"	Standard	-	-	-	-	●

Key  
 ● allowed matching; - not allowed matching

Modular units (F-R-L) code key

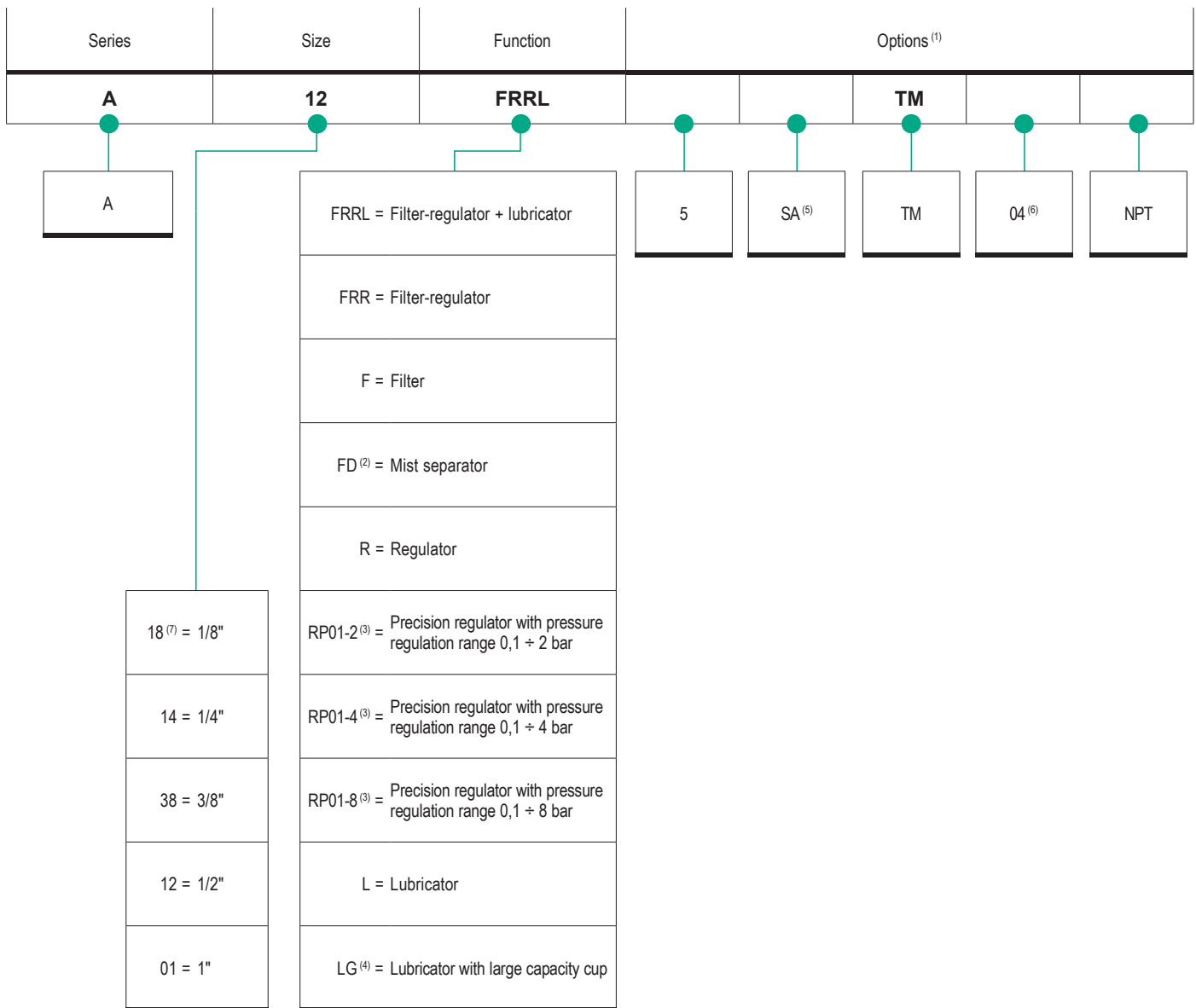

3 - AIR TREATMENT

How to order

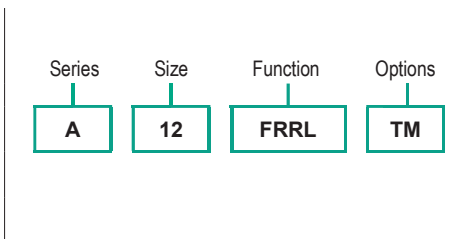

Notes

For standard materials see table at page 3.2.8

Options in the same grid are alternative to each others.

(1) For further information on options and their matching see from page 3.2.4

(2) Mist separator type FD available in sizes 3/8", 1/2" and 1" only.

(3) Precision regulator type RP available in sizes 1/8", 1/4" and 1/2" only.

(4) Lubricator with large capacity cup type LG available in size 1/4" only.

(5) Automatic condens drain (SA) option, available in sizes 3/8", 1/2" and 1" only.

(6) Available for regulators types R, FRR and FRRL only.

For examples of possible combinations between modular components, see from page 3.2.10

Combining modular components require spacers (with seals) and/or brackets, to be ordered separately, see page 3.2.300

For accessories, to be ordered separately, see from page 3.2.12

For spare parts, to be ordered separately, see from page 3.2.400

Modular soft-start valves code key

Series	Size	Actuation	Options <sup>(1)</sup>
<b>AVP</b>	<b>12</b>	<b>E</b>	<b>NPT</b>
AVP	14 = 1/4" 38 = 3/8" 12 = 1/2"	E = Electric P = Pneumatic	NPT

How to order



Notes

For standard materials see table at page 3.2.9  
Options in the same grid are alternative to each others.  
(1) For further information on options and their matching see from page 3.2.4  
For examples of possible combinations between modular components, see from page 3.2.10  
Combining modular components require spacers (with seals) and/or brackets, to be ordered separately, see page 3.2.300  
For accessories (including coils and connectors for solenoid operated valves), to be ordered separately, see from page 3.2.12

Modular exhaust manual operated valves code key

Series	Size	Options <sup>(1)</sup>
<b>VMS</b>	<b>12</b>	<b>NPT</b>
VMS	14 = 1/4" 38 = 3/8" 12 = 1/2" 01 = 1"	NPT

How to order

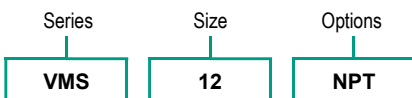

Notes

For standard materials see table at page 3.2.9  
Options in the same grid are alternative to each others.  
(1) For further information on options and their matching see from page 3.2.4  
For examples of possible combinations between modular components, see from page 3.2.10  
Combining modular components require spacers (with seals) and/or brackets, to be ordered separately, see page 3.2.300  
For accessories, to be ordered separately, see from page 3.2.12

Standard materials for modular filters, regulators and lubricators

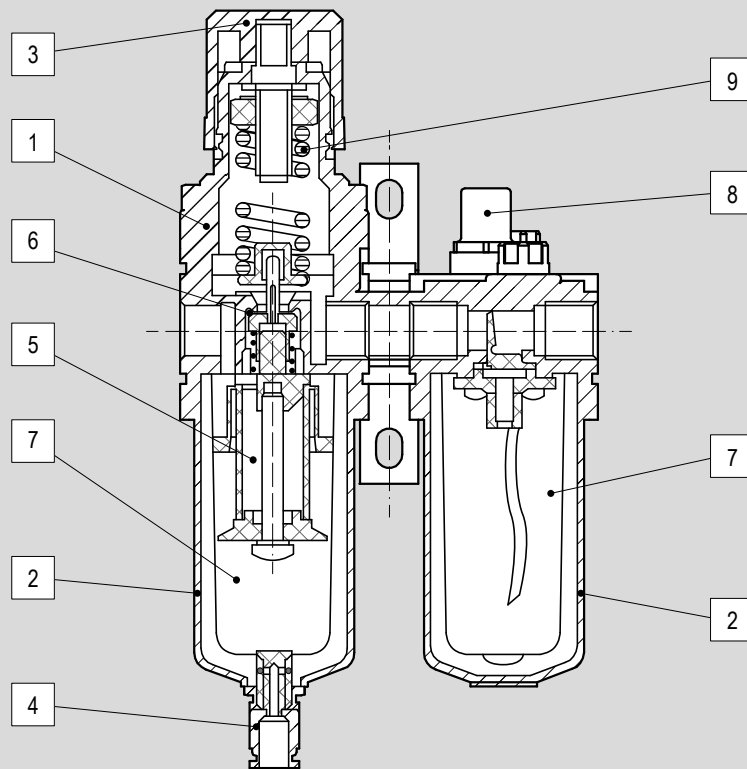

3 - AIR TREATMENT

Position	Description	Material
1	Body	Die-cast aluminium
2	Cup protection	Die-cast aluminium
3	Regulation group	Plastic
4	Condense drain	Nickel-plated brass
5	Filtering element	Sintered bronze
6	Diaphragm	NBR
7	Cups	Polycarbonate
8	Sight-glass	Polycarbonate
9	Springs	Spring steel



Standard materials for modular soft-start valves

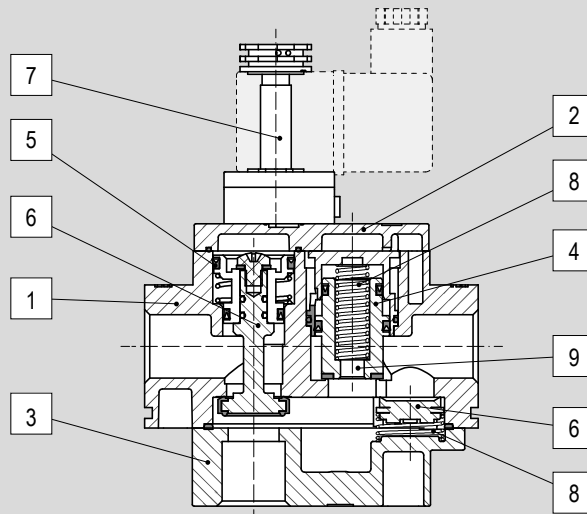

Position	Description	Material
1	Body	Painted aluminium
2	Cover	Painted aluminium
3	End cover	Painted aluminium
4	Piston guide	POM / NBR
5	Seals	NBR
6	Internal components	Brass / NBR
7	Plunger	Brass
8	Springs	Stainless Steel
9	Piston	Brass / NBR

Standard materials for modular exhaust manual operated valves

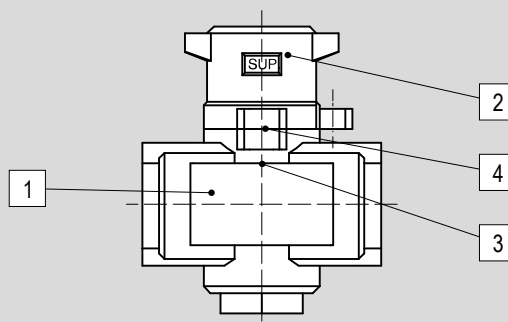

Position	Description	Material
1	Body	Painted aluminium
2	Knob	Painted aluminium
3	Seals	NBR
4	Bush	Stainless Steel

Most commonly used optional combinations

Type: **F+R+L**

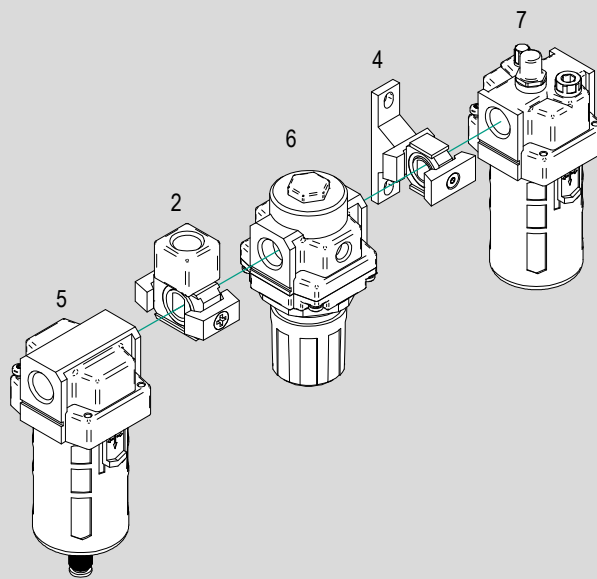

Type: **FRRL+AVP..E**

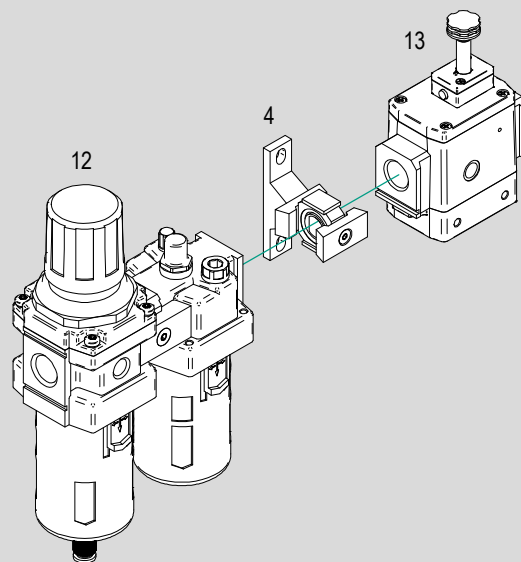

Type: **FRRL+VMS**

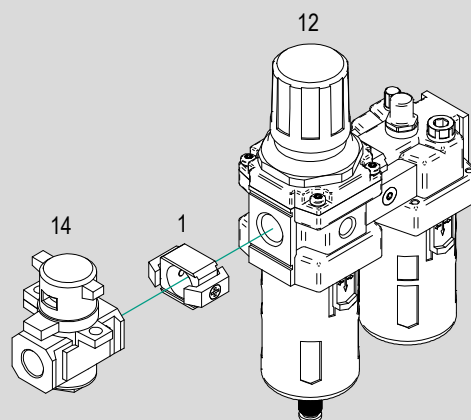

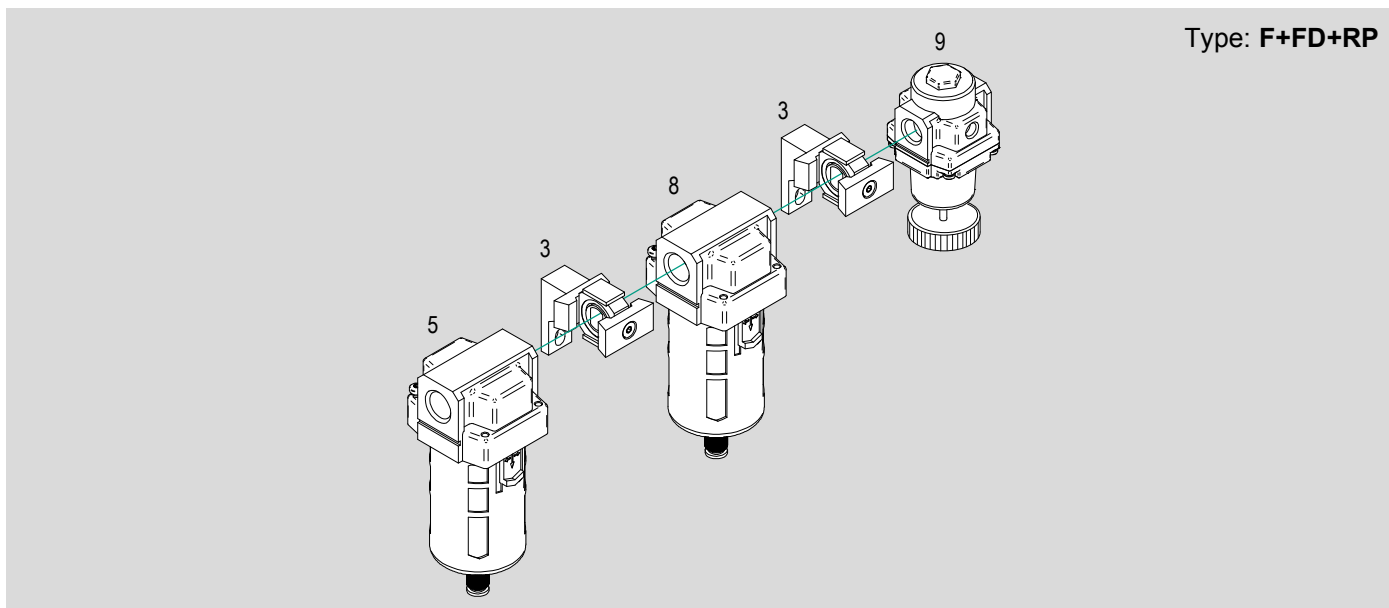

Type: **F+FD+RP**

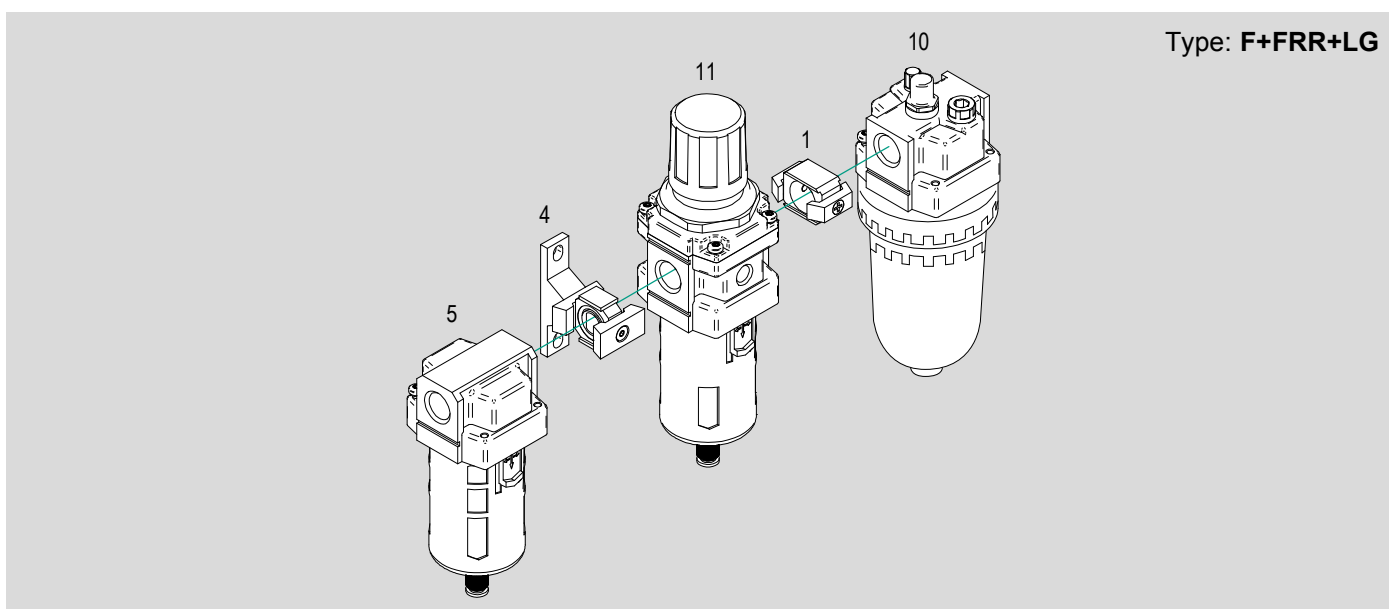

Type: **F+FRR+LG**

N.	Size	Item	Description	Data sheet page
1	1/4" ÷ 1"	D	Spacer	3.92.1
2	1/4" ÷ 1"	DT	Spacer with "T" type porting block	3.92.1
3	1/4" ÷ 1"	DSL	Spacer with "L" type bracket	3.92.2
4	1/4" ÷ 1"	DST	Spacer with "T" type bracket	3.92.3
5	1/4" ÷ 1"	F	Filter	3.2.20
6	1/4" ÷ 1"	R	Regulator	3.2.50
7	1/4" ÷ 1"	L	Lubricator	3.2.80
8	3/8" ÷ 1"	FD	Mist separator	3.2.30
9	1/8" ÷ 1/2"	RP	Precision regulator	3.2.60
10	1/4"	LG	Lubricator with large capacity cup	3.2.90
11	1/4" ÷ 1"	FRR	Filter-regulator	3.2.110
12	1/4" ÷ 1"	FRRL	Filter-regulator+lubricator	3.2.140
13	1/4" ÷ 1/2"	AVP..E	Soft-start solenoid operated valve	3.2.200
14	1/4" ÷ 1"	VMS	Exhaust manual operated valve	3.2.250

Accessories

3 - AIR TREATMENT

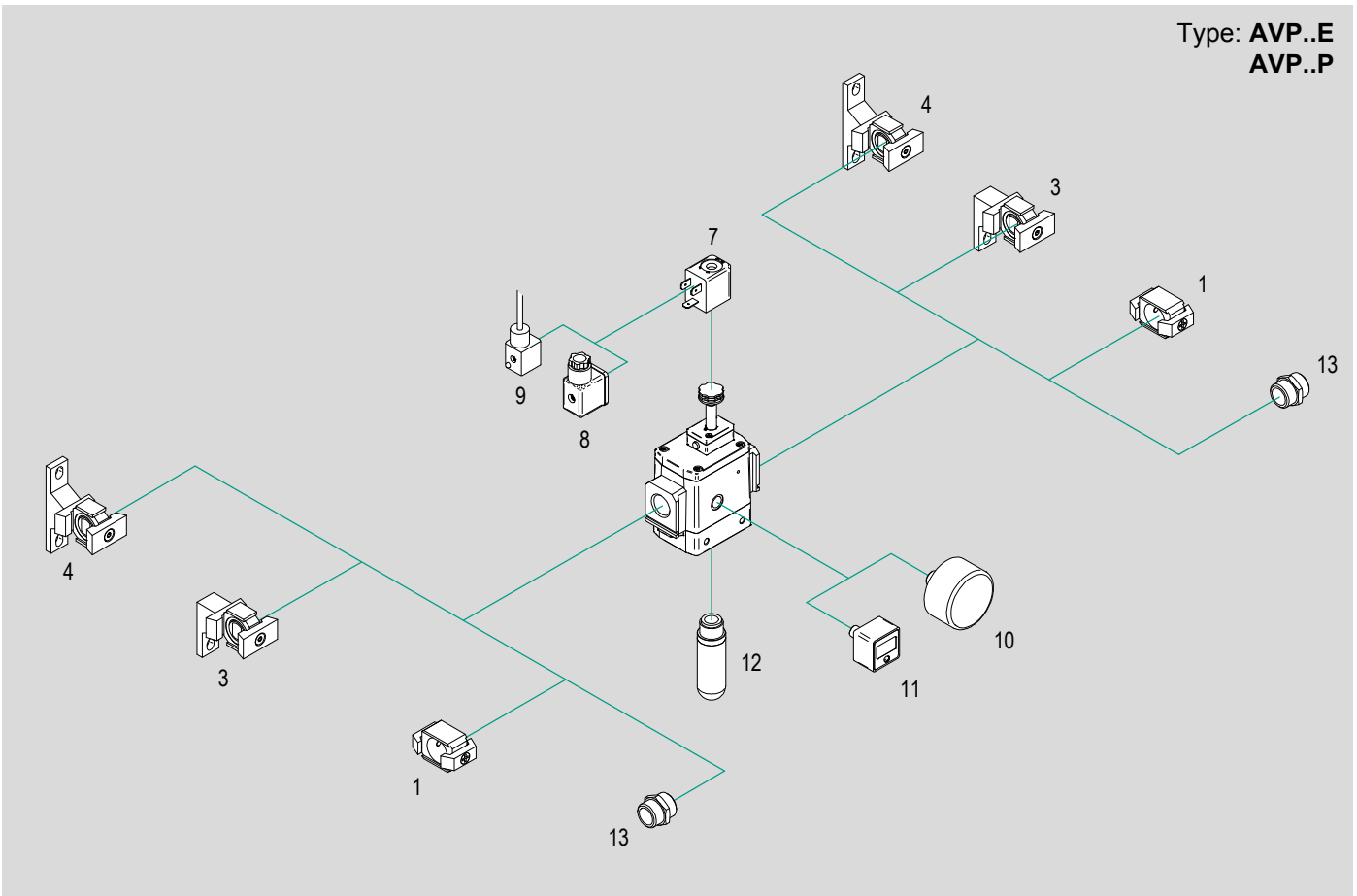
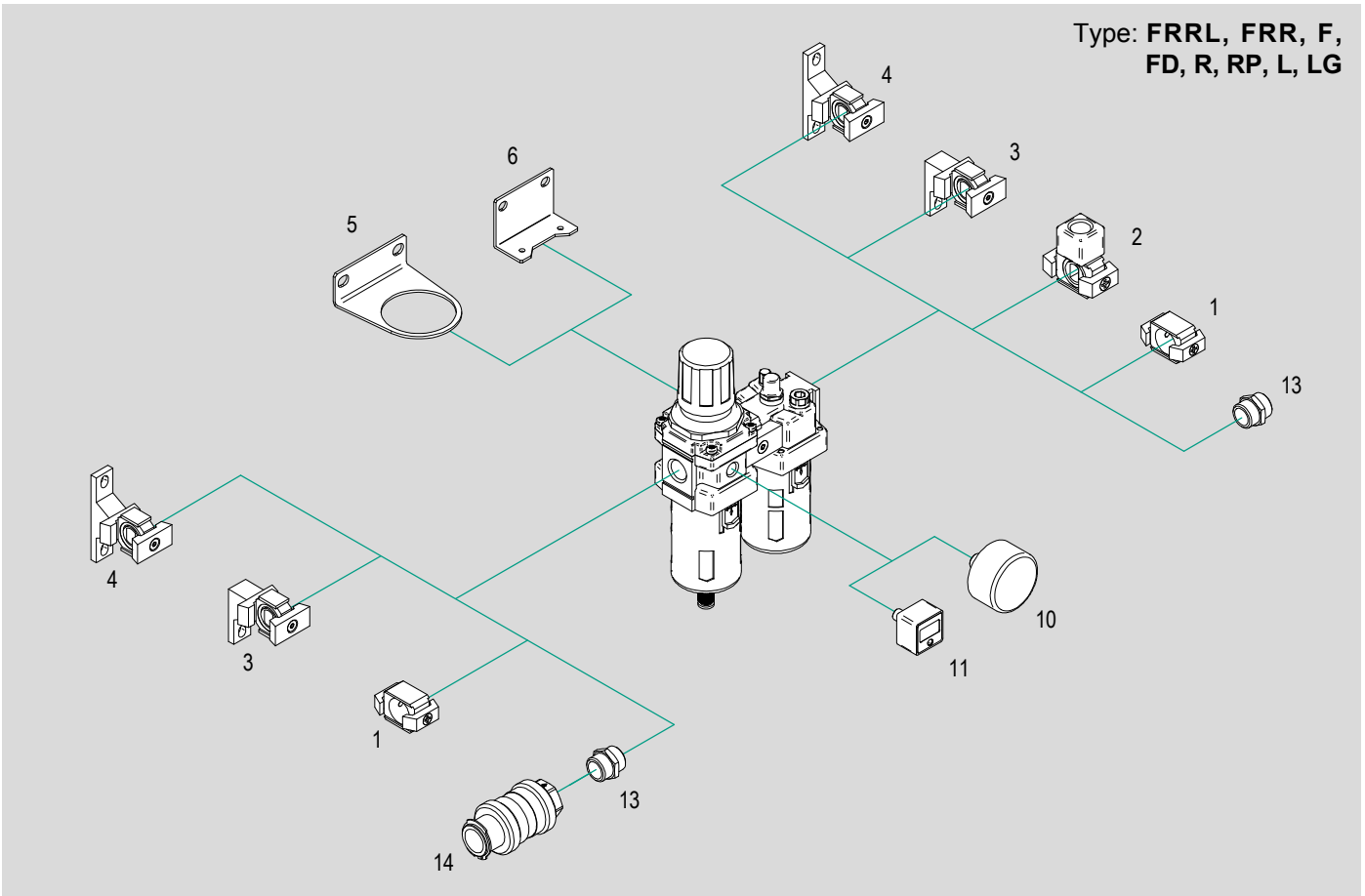

Type: VMS

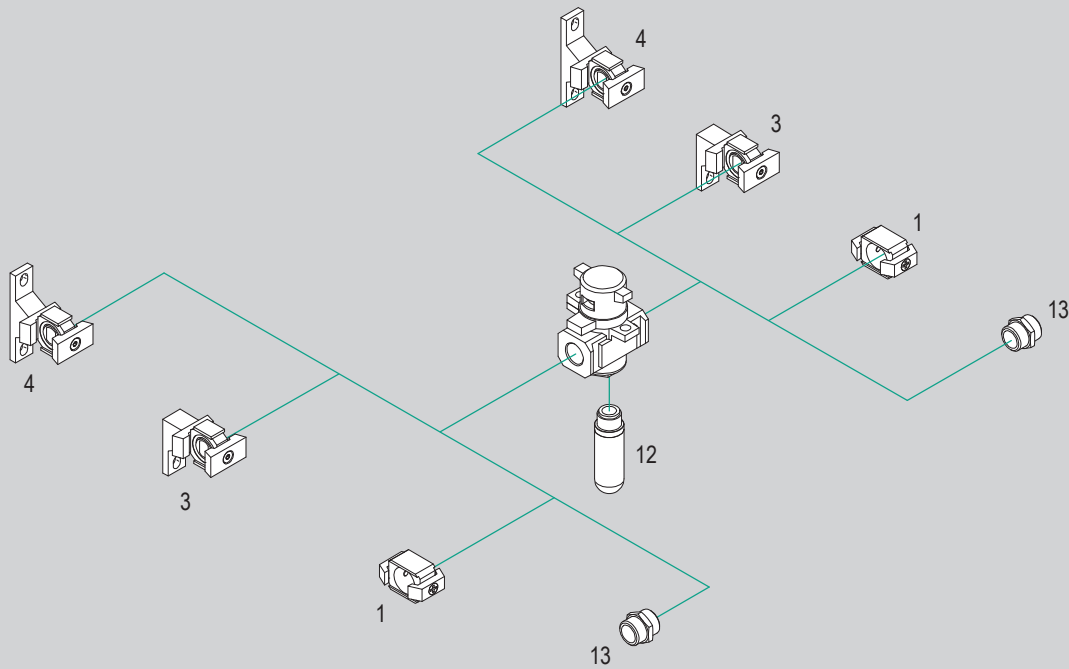

N.	Size	Item	Description	Matching											Code key page	Data sheet page	
				FRRL	FRR	F	FD	R	RP	L	LG	AVP..E	AVP..P	VMS			
1	1/4" ÷ 1"	D..	Spacer	●	●	●	●	●	●	●	●	●	●	●	●	3.2.300	3.92.1
2	1/4" ÷ 1"	DT..	Spacers with "T" type porting block	● <sup>1</sup>	-	●	●	●	●	● <sup>1</sup>	● <sup>1</sup>	-	-	-	3.92.1		
3	1/4" ÷ 1"	DSL..	Spacer with "L" type bracket	●	●	●	●	●	●	●	●	●	●	●	3.92.2		
4	1/4" ÷ 1"	DST..	Spacer with "T" type bracket	● <sup>2</sup>	●	●	●	●	●	●	●	●	●	●	3.92.3		
5	1/4" ÷ 1"	SR..	Mounting brackets	●	●	-	-	●	-	-	-	-	-	-	3.94.1		
6	1/4" ÷ 1"	SL..		-	-	-	-	-	-	●	-	-	-	-	3.94.2		
	1/8" ÷ 1/2"	SRP..		-	-	-	-	-	●	-	-	-	-	-			
7	1/4" ÷ 1/2"	ASA12..	Coils	-	-	-	-	-	-	-	-	●	-	-	2.315.1		
8	1/4" ÷ 1/2"	A12209N..	Connectors	-	-	-	-	-	-	-	-	●	-	-	2.318.1		
9	1/4" ÷ 1/2"	A12209NK..	Cabled connectors	-	-	-	-	-	-	-	-	●	-	-			
10	1/4" ÷ 1"	M..	Analogic pressure-gauges	●	●	-	-	●	●	-	-	●	●	-	3.30.20		
11	1/4" ÷ 1"	AKP60P..	Digital pressure-gauges	●	●	-	-	●	●	-	-	●	●	-	3.30.40		
12	1/4" ÷ 1"	AS..	Plastic silencers	-	-	-	-	-	● <sup>3</sup>	-	-	●	●	●	4.151.20		
13	1/4" ÷ 1"	A..	BSP nipple male/ male	●	●	●	●	●	●	●	●	●	●	●	4.35.1		
14	1/4" ÷ 1/2"	V26..	Slide valves	●	●	●	●	●	●	●	●	-	-	-	3.2.90	2.251.1	

Key  
 ● matching accessory; - not matching accessory

1) On the lubricator can only be mounted to the "out" port  
 2) supplied as standard  
 3) for size 1/2" only

3 - AIR TREATMENT



# Modular units

## Filters, 1/4" ÷ 1"



### Main features

Code	Item	Size	Function	Symbol
090102	A14F	1/4"	Filter	
090107	A38F	3/8"		
090112	A12F	1/2"		
090117	A01F	1"		



### Technical data

Type	A14F	A38F	A12F	A01F
Size	1/4"	3/8"	1/2"	1"
Fluid	Compressed air			
Maximum inlet pressure	10 bar			
Temperature range	0°C ÷ +60°C			
Flow (at 6 bar)	750 NI/min.	1500 NI/min.	4000 NI/min.	7000 NI/min.
Filtering element	25 µm (standard)		5 µm (5)	
Cup capacity	15 cm <sup>3</sup>	20 cm <sup>3</sup>	45 cm <sup>3</sup>	130 cm <sup>3</sup>
Condense drain	Semi-automatic		Semi-automatic (standard) Automatic (SA)	
Weight	180 g	260 g	520 g	1040 g

### Notes

Spacers and mounting brackets to be ordered separately, see page 3.2.300  
 For spare parts see from page 3.2.400

Standard dimensions

Type: **A14F**

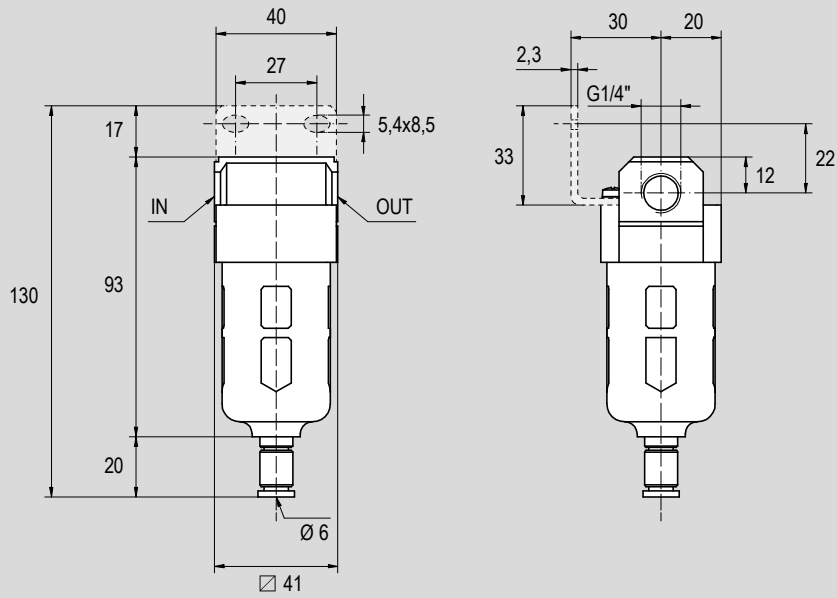

3 - AIR TREATMENT

Size	Function	Symbol	Code	Item
1/4"	Filter		090102	A14F



Standard dimensions

Type: **A38F**

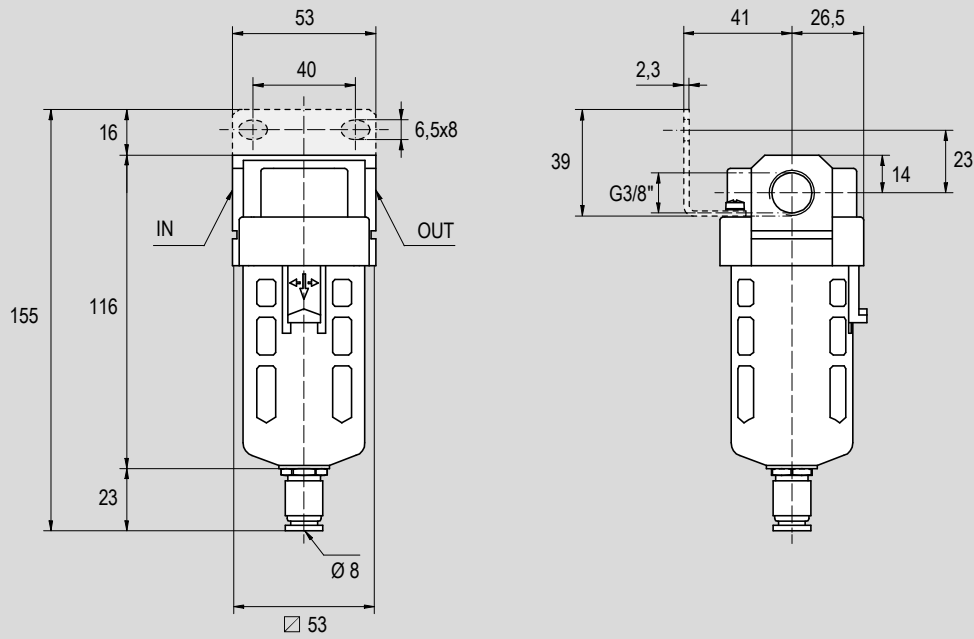

Size	Function	Symbol	Code	Item
3/8"	Filter		090107	A38F

Standard dimensions

Type: **A12F**

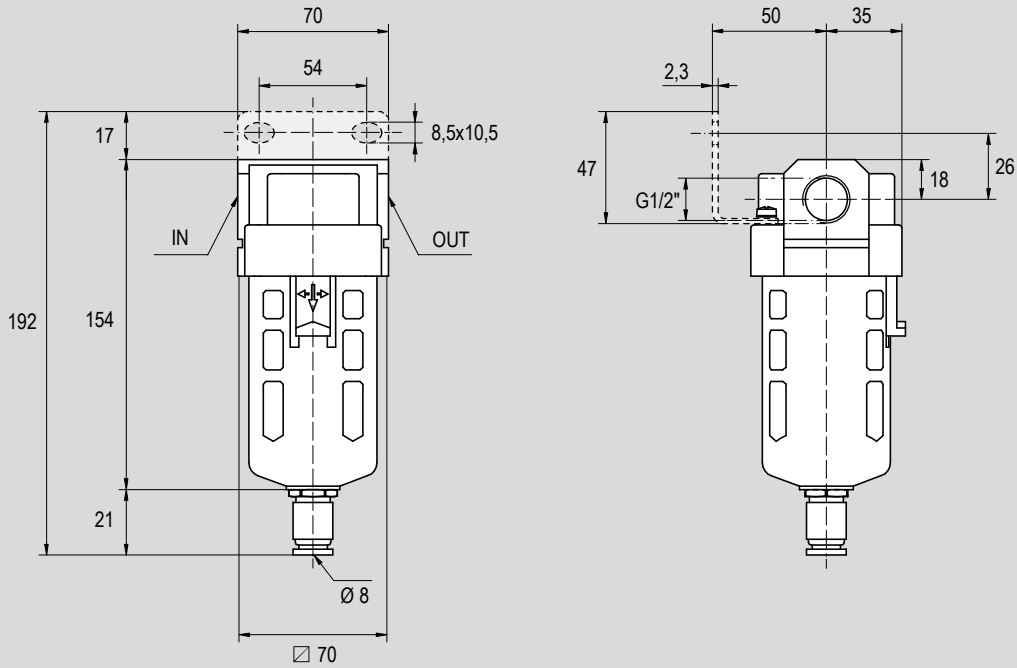

3 - AIR TREATMENT

Size	Function	Symbol	Code	Item
1/2"	Filter		090112	A12F

Standard dimensions

Type: **A01F**

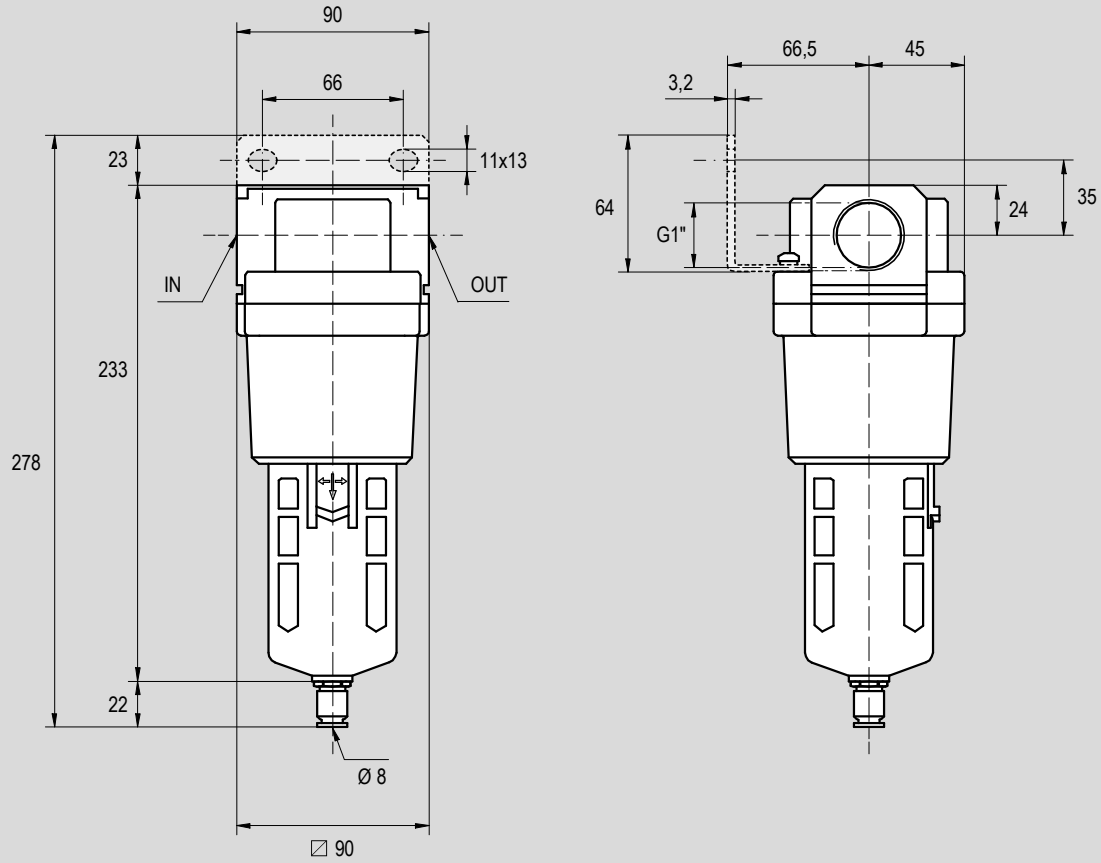

Size	Function	Symbol	Code	Item
1"	Filter		090117	A01F

## Modular units

Mist separators, 3/8" ÷ 1"



### Main features

Code	Item	Size	Function	Symbol
090268	A38FD	3/8"	Mist separator	
090269	A12FD	1/2"		
090270	A01FD	1"		



### Technical data

Type	A38FD	A12FD	A01FD
Size	3/8"	1/2"	1"
Fluid	Compressed air		
Maximum inlet pressure	10 bar		
Temperature range	0°C ÷ +60°C		
Flow (at 6 bar)	800 NI/min.	2000 NI/min.	2500 NI/min.
Filtering element	0.3 µm		
Cup capacity	20 cm <sup>3</sup>	45 cm <sup>3</sup>	130 cm <sup>3</sup>
Condense drain	Semi-automatic (standard)		Automatic (SA)
Weight	290 g	520 g	1050 g

### Notes

Spacers and mounting brackets to be ordered separately, see page 3.2.300

For spare parts see from page 3.2.400

Standard dimensions

Type: **A38FD**

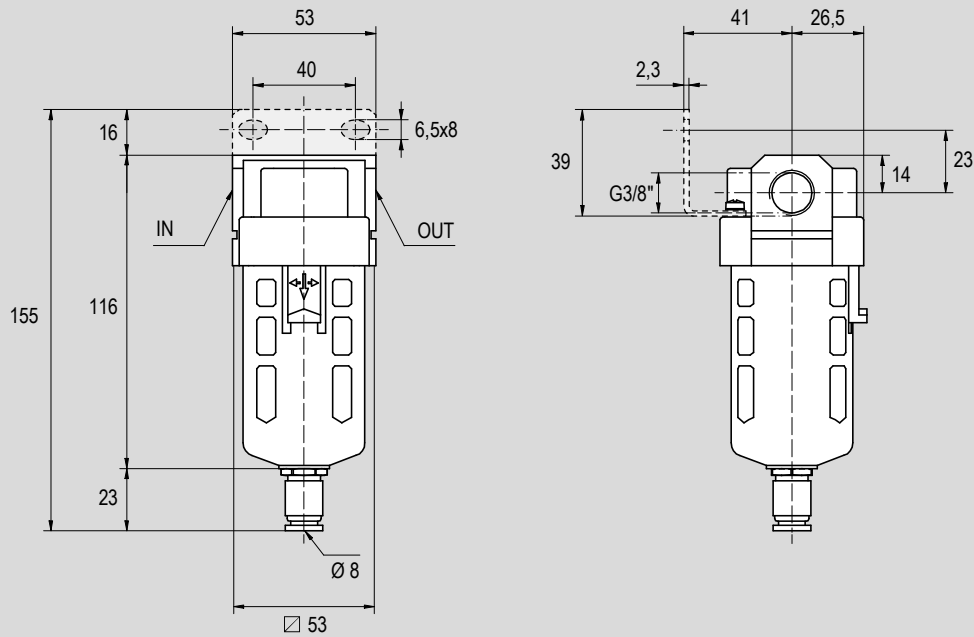

Size	Function	Symbol	Code	Item
3/8"	Mist separator		090268	A38FD

Standard dimensions

Type: A12FD

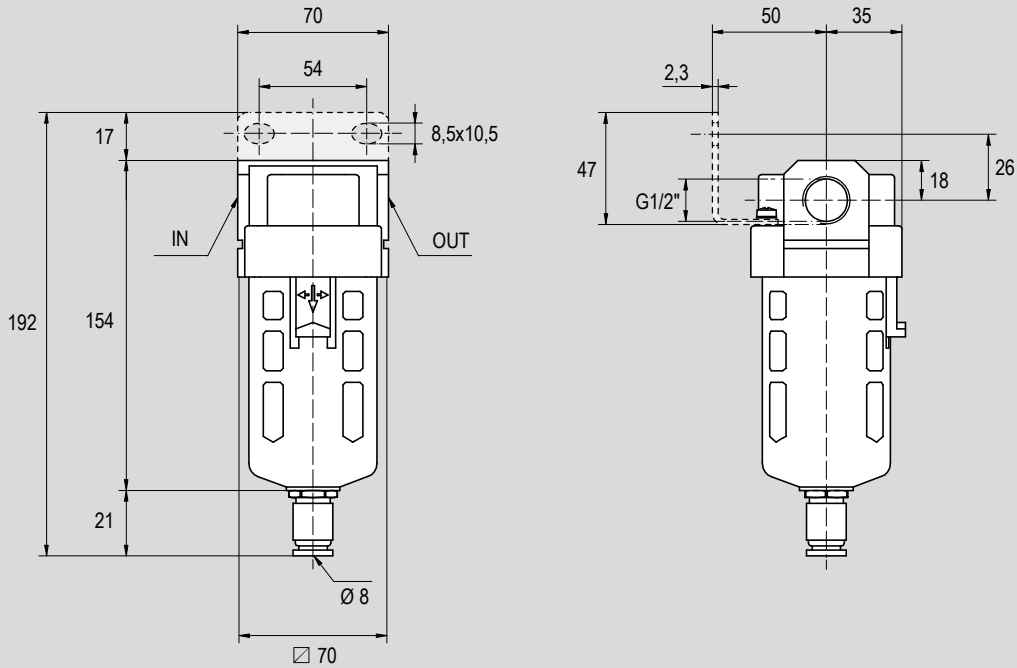

3 - AIR TREATMENT

Size	Function	Symbol	Code	Item
1/2"	Mist separator		090269	A12FD

Standard dimensions

Type: A01FD

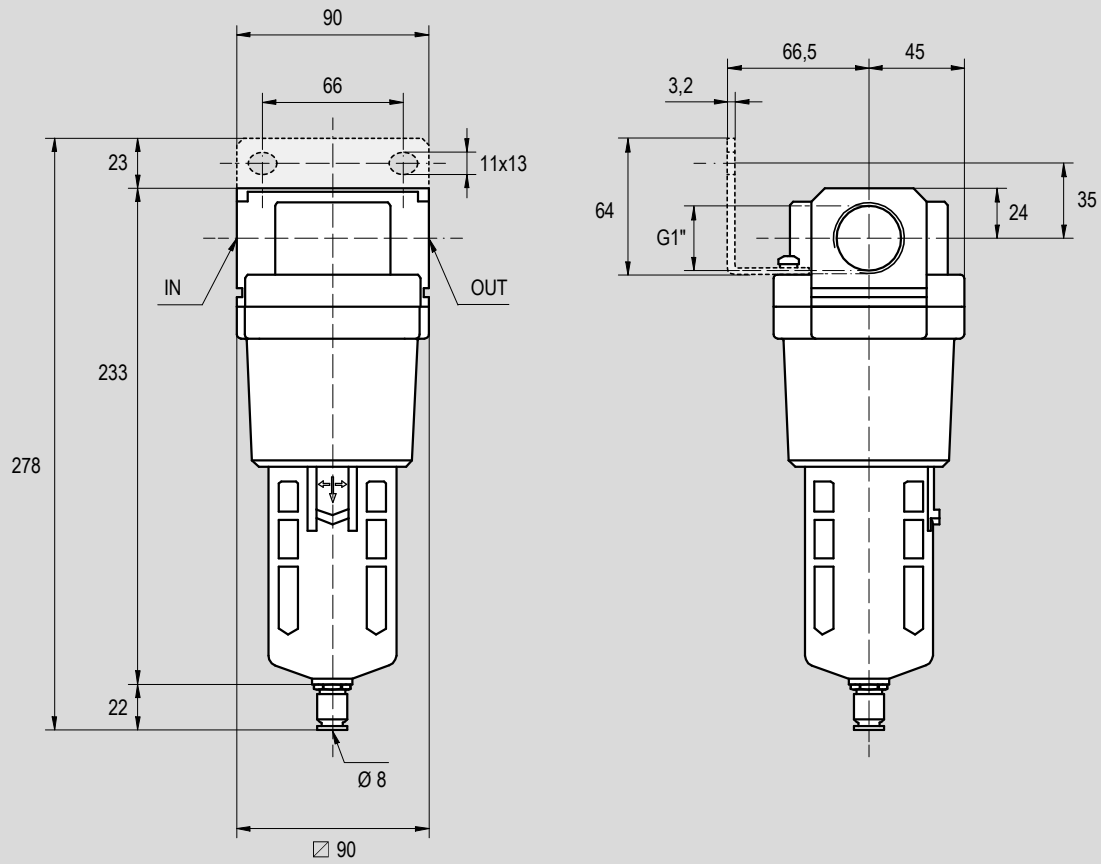





Size	Function	Symbol	Code	Item
1"	Mist separator		090270	A01FD

# Modular units

## Regulators, 1/4" ÷ 1"



### Main features

Code	Item	Size	Function	Symbol
090103	 A14R	1/4"	Regulator	
090108	 A38R	3/8"		
090113	 A12R	1/2"		
090118	A01R	1"		



### Technical data

Type	A14R	A38R	A12R	A01R
Size	1/4"	3/8"	1/2"	1"
Fluid	Compressed air			
Maximum inlet pressure	10 bar			
Pressure regulation range	0,5 ÷ 8,5 (standard)		0,5 ÷ 4 (04)	
Temperature range	0°C ÷ +60°C			
Flow (at 6 bar)	550 NI/min.	2500 NI/min.	6000 NI/min.	8000 NI/min.
Pressure regulator	Piston			
Overpressure relief	Relieving			
Gauges port	1/8"		1/4"	
Weight	270 g	410 g	840 g	1190 g

### Notes

Spacers and mounting brackets to be ordered separately, see page 3.2.300  
 Pressure-gauges to be ordered separately, see from page 3.30.1



Standard dimensions

Type: **A14R**

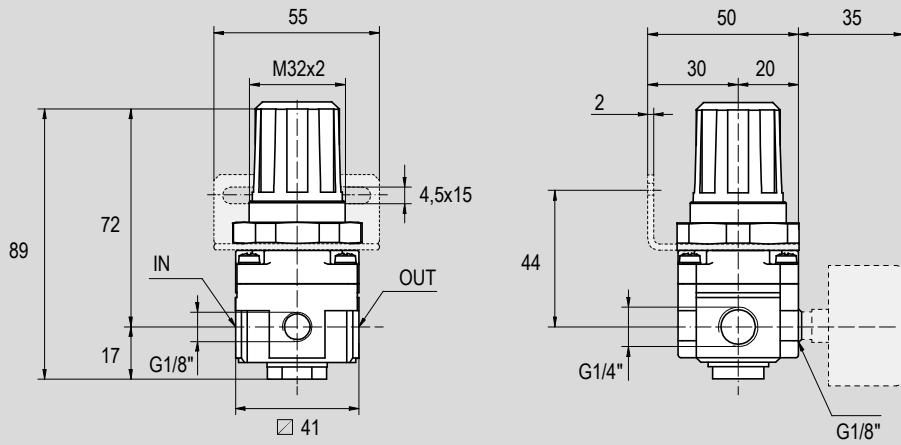

Size	Function	Symbol	Code	Item
1/4"	Regulator		090103	A14R

Standard dimensions

Type: **A38R**

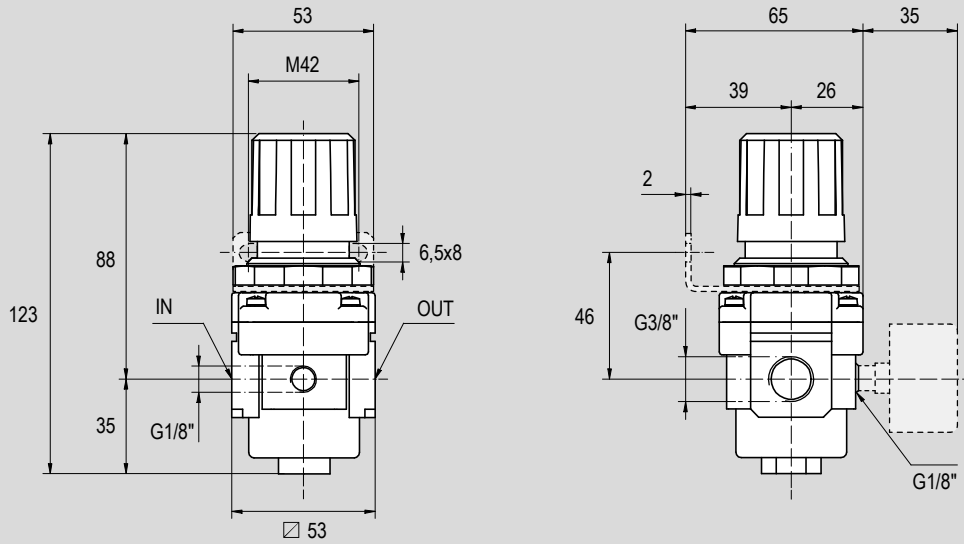

3 - AIR TREATMENT

Size	Function	Symbol	Code	Item
3/8"	Regulator		090108	A38R

Standard dimensions

Type: **A12R**

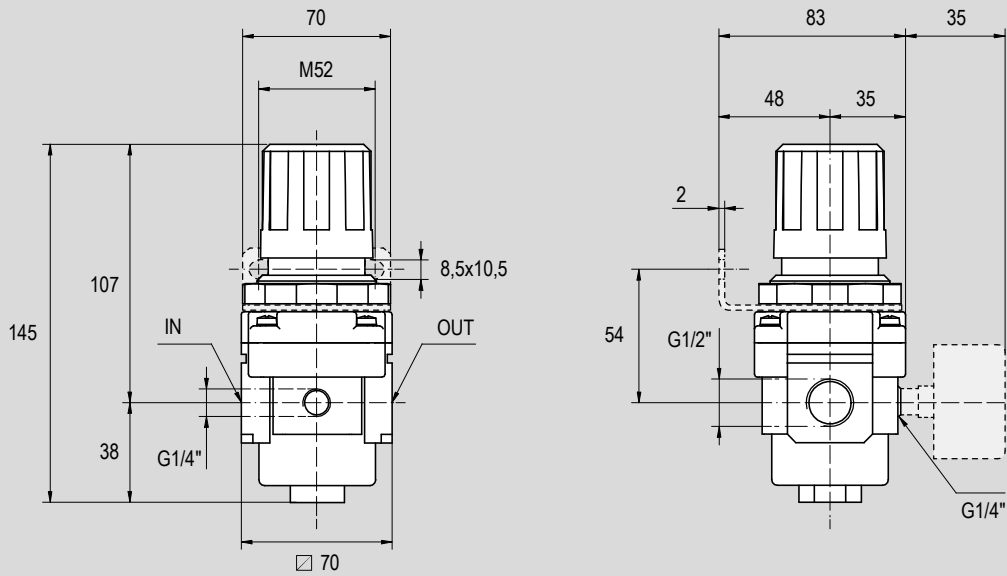

Size	Function	Symbol	Code	Item
1/2"	Regulator		090113	A12R

Standard dimensions

Type: **A01R**

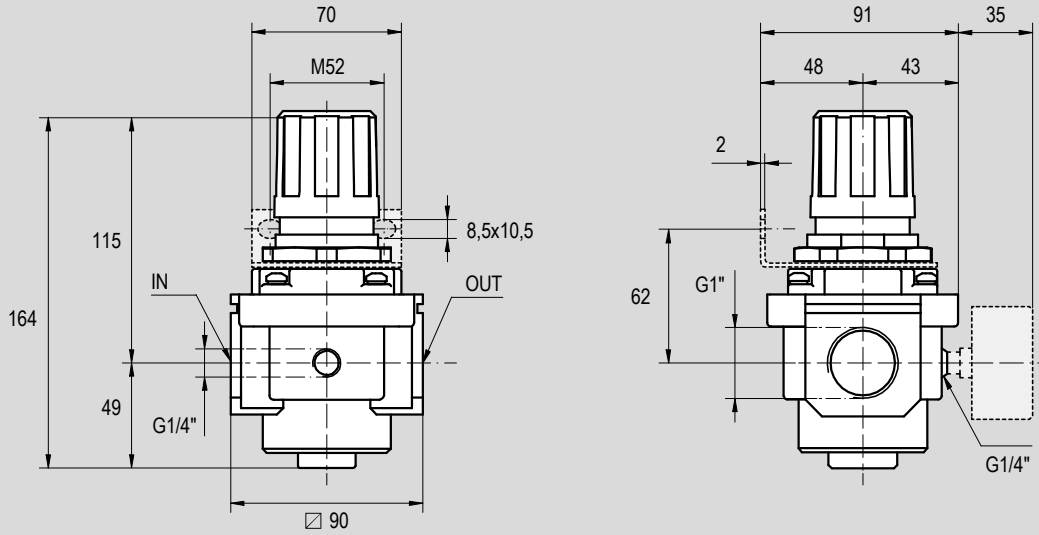

3 - AIR TREATMENT

Size	Function	Symbol	Code	Item
1"	Regulator		090118	A01R

# Modular units

Precision regulators, 1/8" ÷ 1/2"



## Main features

Code	Item	Size	Function	Symbol
090271	A18RP01-2	1/8"	Precision regulator	
090272	A18RP01-4			
090273	A18RP01-8			
090274	A14RP01-2	1/4"		
090275	A14RP01-4			
090276	A14RP01-8			
090277	A12RP01-2	1/2"		
090278	A12RP01-4			
090279	A12RP01-8			



## Technical data

Type	A18RP01-2	A18RP01-4	A18RP01-8	A14RP01-2	A14RP01-4	A14RP01-8	A12RP01-2	A12RP01-4	A12RP01-8
Size	1/8"			1/4"			1/2"		
Fluid	Compressed air								
Maximum inlet pressure	10 bar								
Pressure regulation range	0,1 ÷ 2 bar	0,1 ÷ 4 bar	0,1 ÷ 8 bar	0,1 ÷ 2 bar	0,1 ÷ 4 bar	0,1 ÷ 8 bar	0,1 ÷ 2 bar	0,1 ÷ 4 bar	0,1 ÷ 8 bar
Temperature range	0°C ÷ +60°C								
Pressure regulator	Piston								
Overpressure relief	Relieving						Relieving + threaded exhaust (1/2")		
Gauges port	1/8"								
Weight	150			330			680		

## Matching note

Size 1/8" can be mounted in combination with modular component size 1/4" only.  
 Size 1/4" can be mounted in combination with modular component size 3/8" only.  
 Size 1/2" can be mounted in combination with modular component size 1/2" only.

## Notes

Spacers and mounting brackets to be ordered separately, see page 3.2.300  
 Pressure-gauges to be ordered separately, see from page 3.30.1

Standard dimensions

Type: A18RP

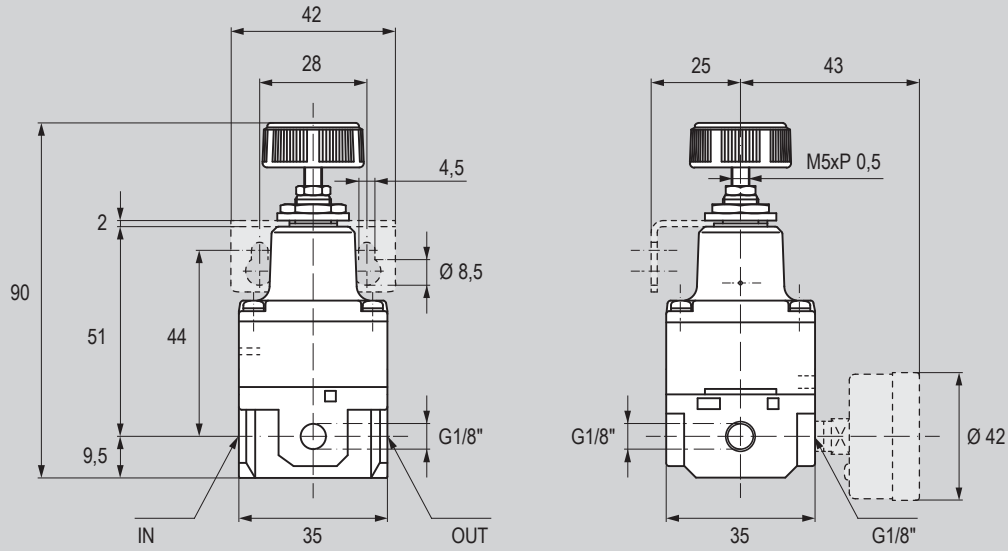

3 - AIR TREATMENT

Size	Function	Pressure regulation range	Symbol	Code	Item
1/8"	Precision regulator	0,1 ÷ 2 bar		090271	A18RP01-2
		0,1 ÷ 4 bar		090272	A18RP01-4
		0,1 ÷ 8 bar		090273	A18RP01-8

Standard dimensions

Type: A14RP

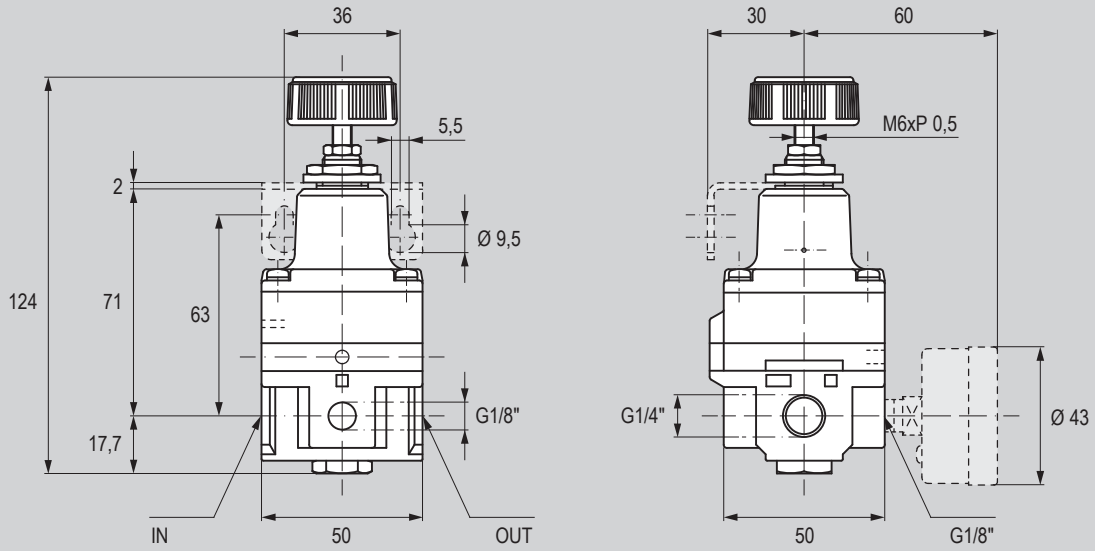

Size	Function	Pressure regulation range	Symbol	Code	Item
1/4"	Precision regulator	0,1 ÷ 2 bar		090274	A14RP01-2
		0,1 ÷ 4 bar		090275	A14RP01-4
		0,1 ÷ 8 bar		090276	A14RP01-8

Standard dimensions

Type: A12RP

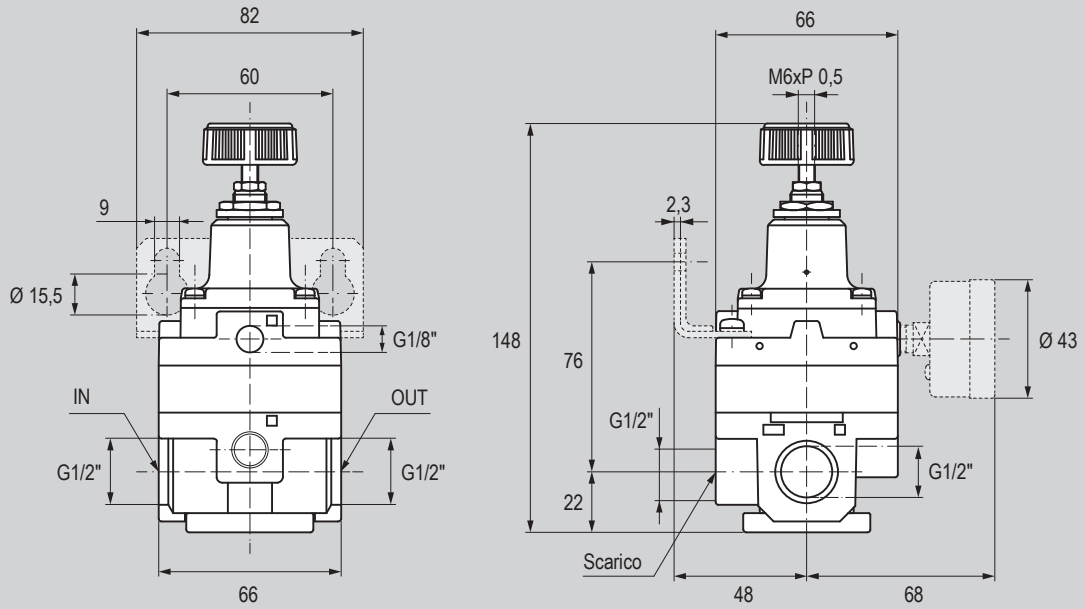

3 - AIR TREATMENT

Size	Function	Pressure regulation range	Symbol	Code	Item
1/2"	Precision regulator	0,1 ÷ 2 bar		090277	A12RP01-2
		0,1 ÷ 4 bar		090278	A12RP01-4
		0,1 ÷ 8 bar		090279	A12RP01-8



Main features

Code	Item	Size	Function	Symbol
090104	A14L	1/4"	Lubricator	
090109	A38L	3/8"		
090114	A12L	1/2"		
090119	A01L	1"		



Technical data

Type	A14L	A38L	A12L	A01L
Size	1/4"	3/8"	1/2"	1"
Fluid	Compressed air			
Maximum inlet pressure	10 bar			
Temperature range	0°C ÷ +60°C			
Flow (at 6 bar)	800 NI/min.	1700 NI/min.	5000 NI/min.	7000 NI/min.
Cup capacity	25 cm <sup>3</sup>	50 cm <sup>3</sup>	130 cm <sup>3</sup>	
Suggested lubricant	With viscosity ISO VG 32 compliant to ISO 3448 standards			
Weight	220 g	300 g	560 g	1080 g

Notes

Spacers and mounting brackets to be ordered separately, see page 3.2.300  
For spare parts see from page 3.2.400

Standard dimensions

Type: **A14L**

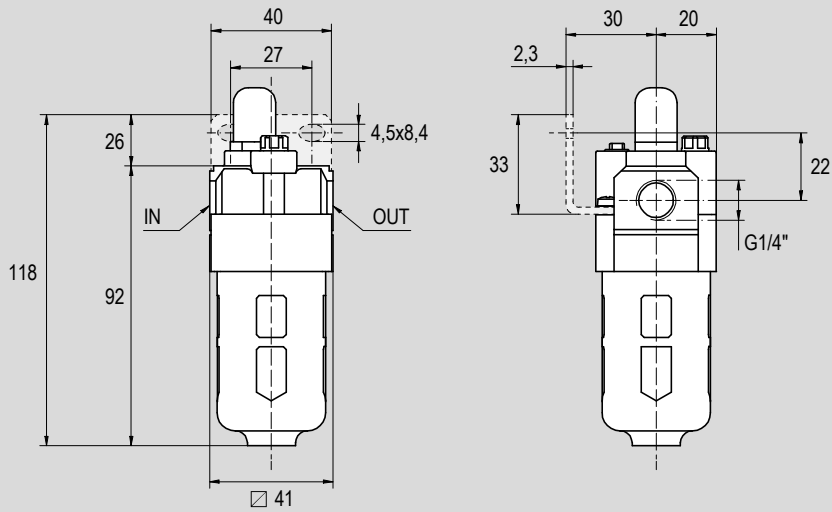

3 - AIR TREATMENT

Size	Function	Symbol	Code	Item
1/4"	Lubricator		090104	A14L

Standard dimensions

Type: **A38L**

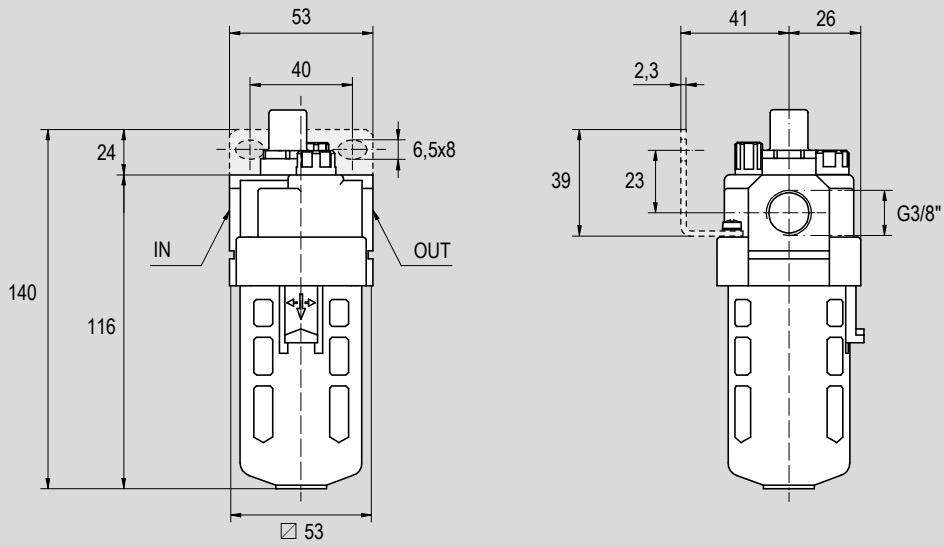

Size	Function	Symbol	Code	Item
3/8"	Lubricator		090109	A38L

Standard dimensions

Type: **A12L**

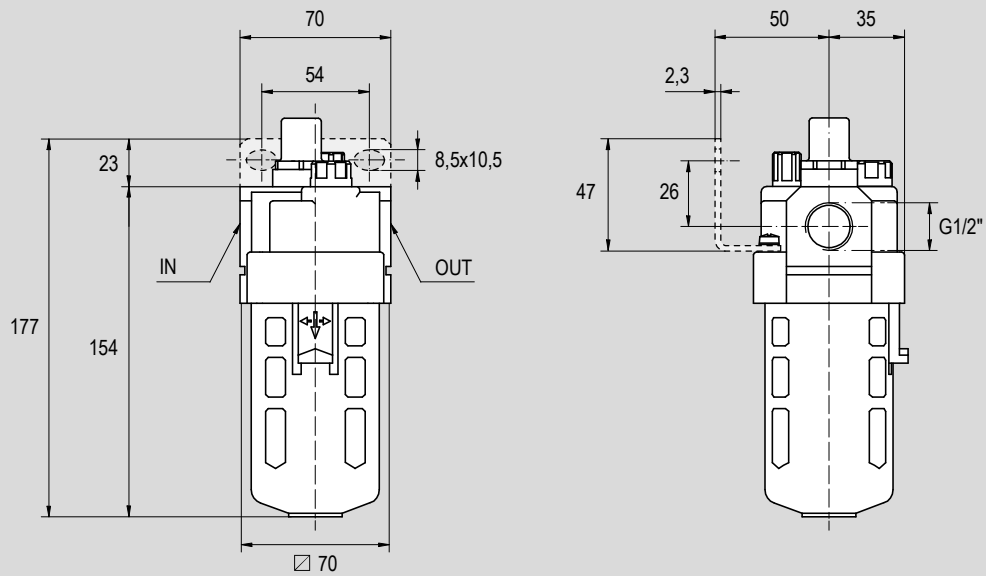

3 - AIR TREATMENT

Size	Function	Symbol	Code	Item
1/2"	Lubricator		090114	A12L

Standard dimensions

Type: **A01L**

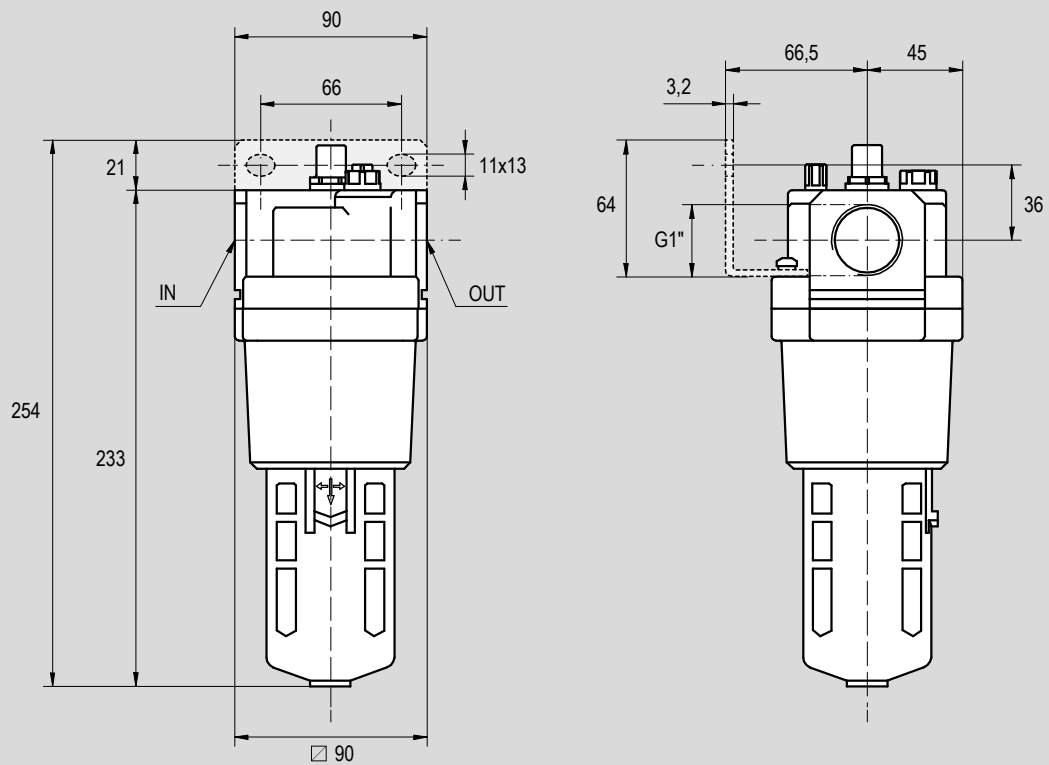

Size	Function	Symbol	Code	Item
1"	Lubricator		090119	A01L

3 - AIR TREATMENT

## Modular units

Lubricators with large capacity cup, 1/4"



### Main features

Code	Item	Size	Function	Symbol
090280	A14LG	1/4"	Lubricators with large capacity cup	



### Technical data

Type	A14LG
Size	1/4"
Fluid	Compressed air
Maximum inlet pressure	10 bar
Temperature range	0°C ÷ +60°C
Flow (at 6 bar)	800 NI/min.
Cup capacity	85 cm <sup>3</sup>
Suggested lubricant	With viscosity ISO VG 32 compliant to ISO 3448 standards

### Notes

Spacers and mounting brackets to be ordered separately, see page 3.2.300

Standard dimensions

Type: A14LG

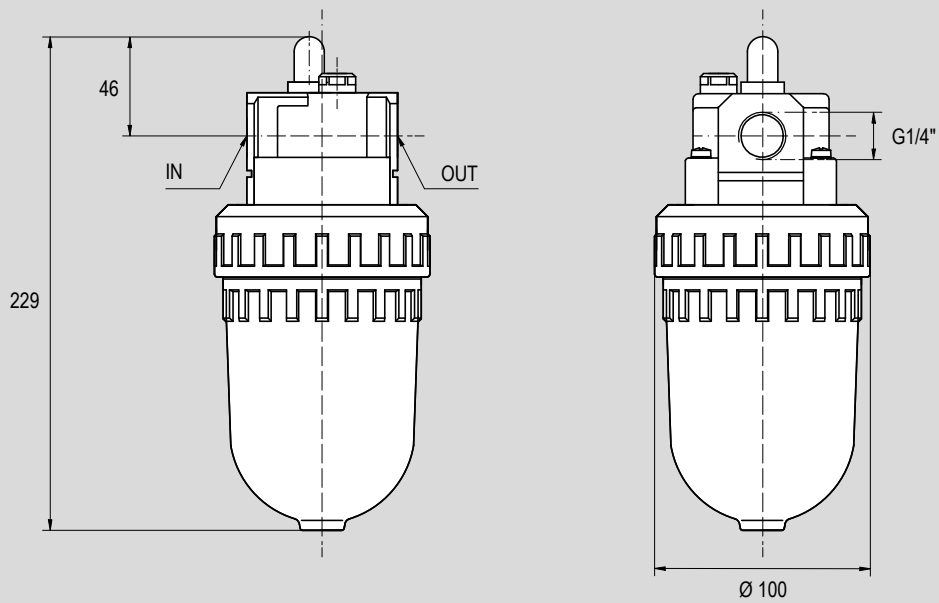

Size	Function	Symbol	Code	Item
1/4"	Lubricator with large capacity cup		090280	A14LG

# Modular units

Filter-regulators, 1/4" ÷ 1"



## Main features

Code	Item	Size	Function	Symbol
090101	A14FRR	1/4"	Filter-regulator	
090106	A38FRR	3/8"		
090111	A12FRR	1/2"		
090116	A01FRR	1"		



## Technical data

Type	A14FRR	A38FRR	A12FRR	A01FRR
Size	1/4"	3/8"	1/2"	1"
Fluid	Compressed air			
Maximum inlet pressure	10 bar			
Pressure regulation range	0,5 ÷ 8,5 (standard)		0,5 ÷ 4 (04)	
Temperature range	0°C ÷ +60°C			
Flow (at 6 bar)	750 NI/min.	2000 NI/min.	4000 NI/min.	5500 NI/min.
Filtering element	25 µm (standard)		5 µm (5)	
Cup capacity	15 cm <sup>3</sup>	20 cm <sup>3</sup>	45 cm <sup>3</sup>	130 cm <sup>3</sup>
Condense drain	Semi-automatic	Semi-automatic (standard)	Automatic (SA)	
Pressure regulator	Piston			
Overpressure relief	Relieving M5			
Gauges port	1/8"		1/4"	
Weight	300 g	530 g	1150 g	1780 g

## Notes

Spacers and mounting brackets to be ordered separately, see page 3.2.300  
 Pressure-gauges to be ordered separately, see from page 3.30.1  
 For spare parts see from page 3.2.400



Standard dimensions

Type: A14FRR

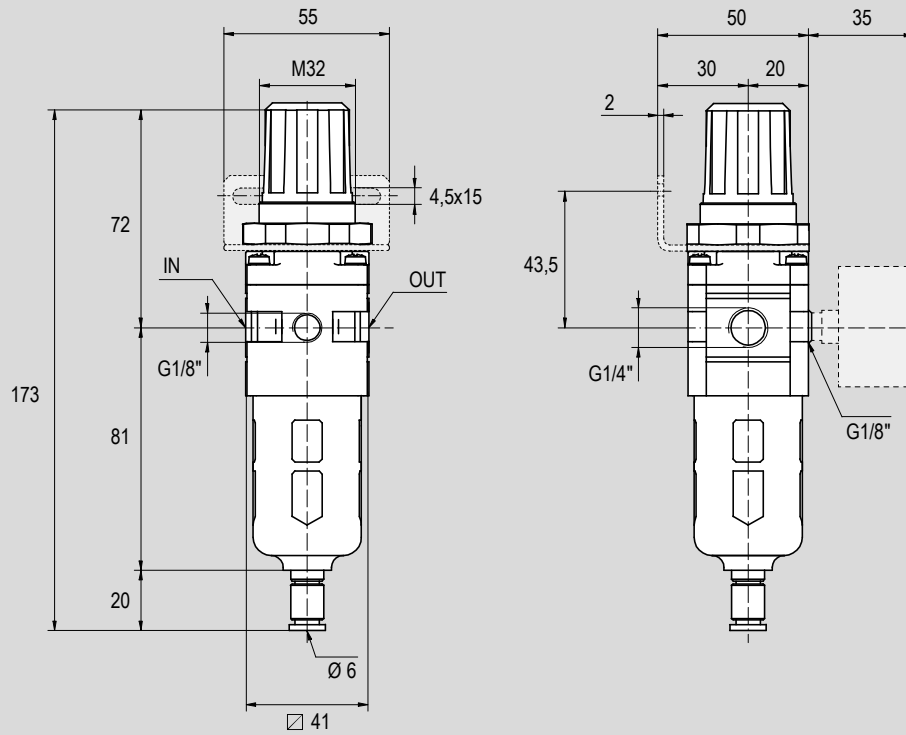

Size	Function	Symbol	Code	Item
1/4"	Filter-regulator		090101	A14FRR

Standard dimensions

Type: **A38FRR**

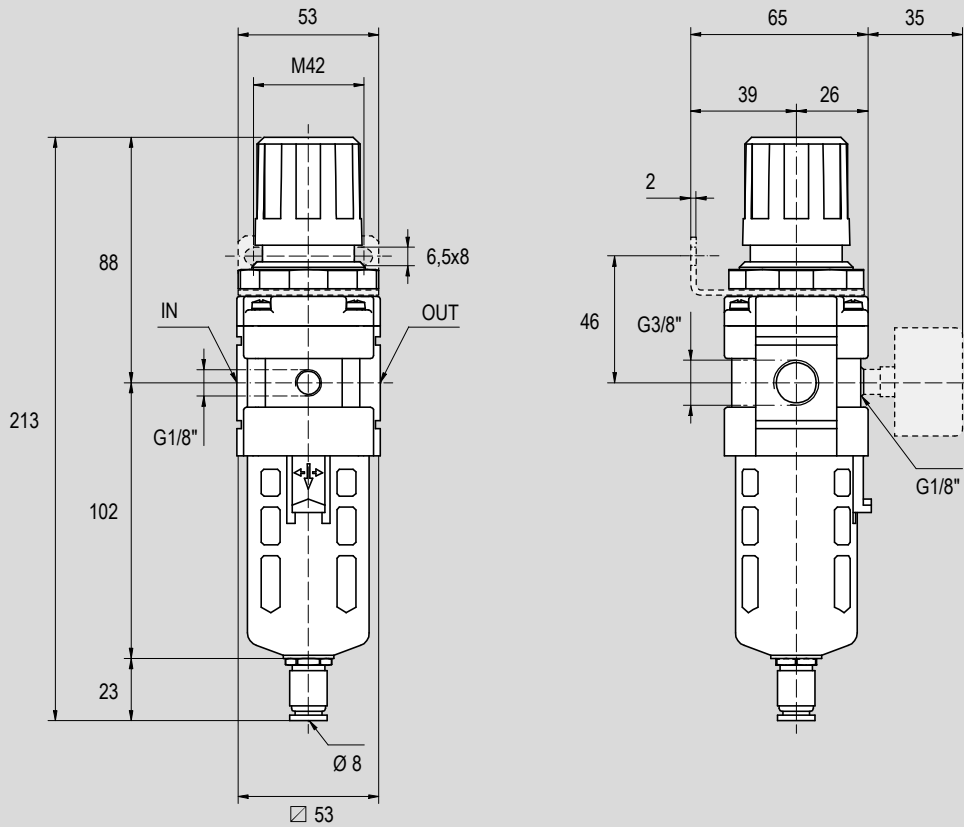

3 - AIR TREATMENT

Size	Function	Symbol	Code	Item
3/8"	Filter-regulator		090106	A38FRR

Standard dimensions

Type: A12FRR

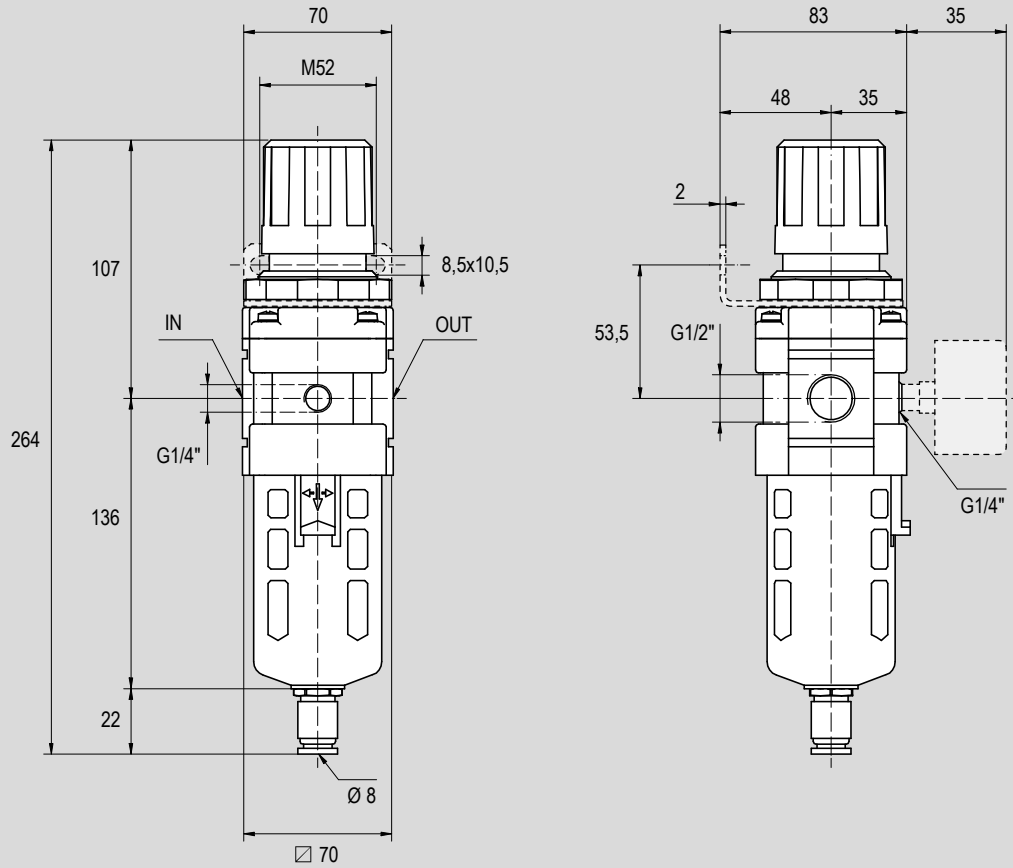

Size	Function	Symbol	Code	Item
1/2"	Filter-regulator		090111	A12FRR

Standard dimensions

Type: **A01FRR**

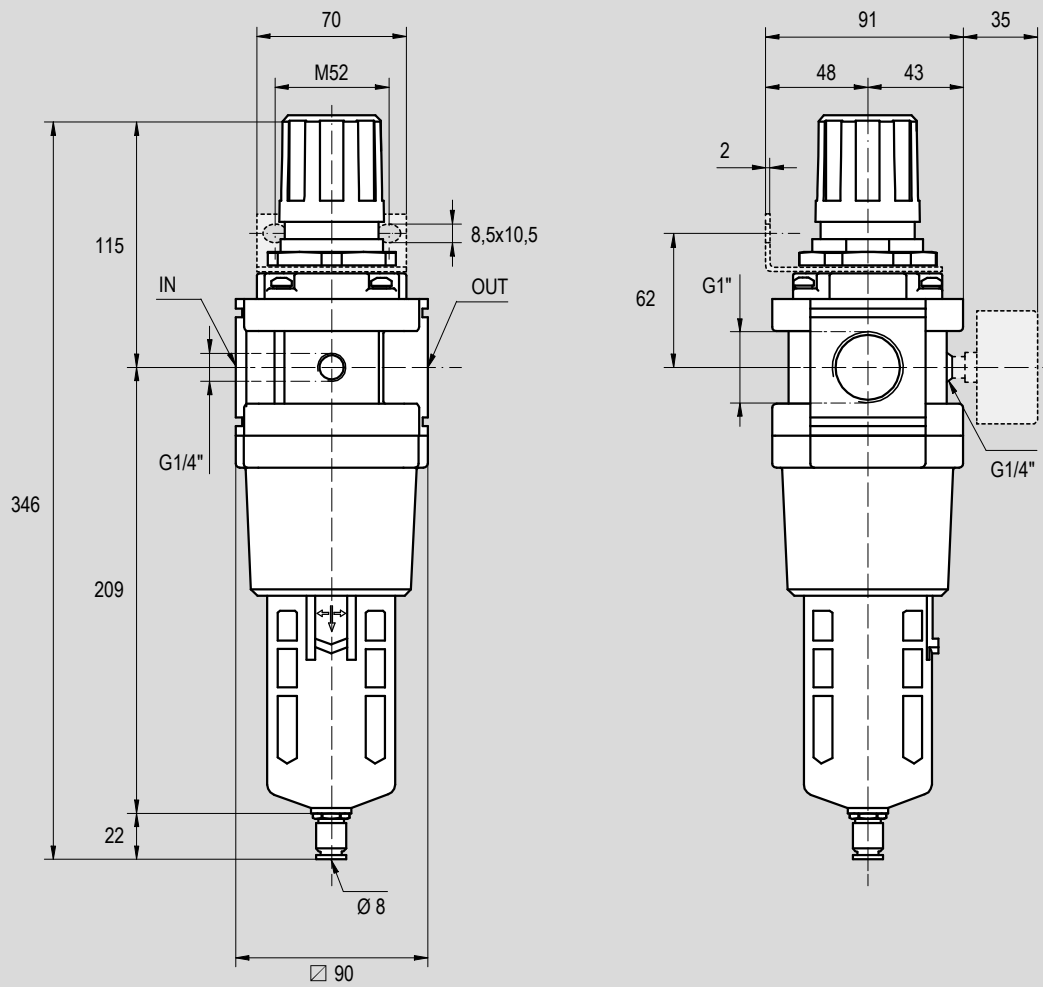

3 - AIR TREATMENT

Size	Function	Symbol	Code	Item
1"	Filter-regulator		090116	A01FRR

# Modular units

Filter-regulators + lubricators, 1/4" ÷ 1"



## Main features

Code	Item	Size	Function	Symbol
090100	A14FRRL	1/4"	Filter-regulator + lubricator	
090105	A38FRRL	3/8"		
090110	A12FRRL	1/2"		
090115	A01FRRL	1"		



## Technical data

Type	A14FRRL	A38FRRL	A12FRRL	A01FRRL
Size	1/4"	3/8"	1/2"	1"
Fluid	Compressed air			
Maximum inlet pressure	0 ÷ 10 bar			
Pressure regulation range	0,5 ÷ 8,5 (standard)		0,5 ÷ 4 (04)	
Temperature range	0°C ÷ +60°C			
Flow (at 6 bar)	500 NI/min.	1700 NI/min.	3000 NI/min.	4000 NI/min.
Filtering element	25 µm (standard)		5 µm (5)	
Cup capacity	filter	15 cm <sup>3</sup>	20 cm <sup>3</sup>	45 cm <sup>3</sup>
	lubricator	25 cm <sup>3</sup>	50 cm <sup>3</sup>	130 cm <sup>3</sup>
Condense drain	Semi-automatic	Semi-automatic	Automatic (SA)	
Pressure regulator	Piston			
Overpressure relief	Relieving M5			
Gauges port	1/8"		1/4"	
Suggested lubricant	With viscosity ISO VG 32 compliant to ISO 3448 standards			
Weight	500 g	950 g	1980 g	3280 g

## Notes

Spacer with "T" type bracket supplied as standard. Other spacers and mounting brackets can be ordered separately, see page 3.2.300  
 Pressure-gauges to be ordered separately, see from page 3.30.1  
 For spare parts see from page 3.2.400

Standard dimensions

Type: A14FRRL

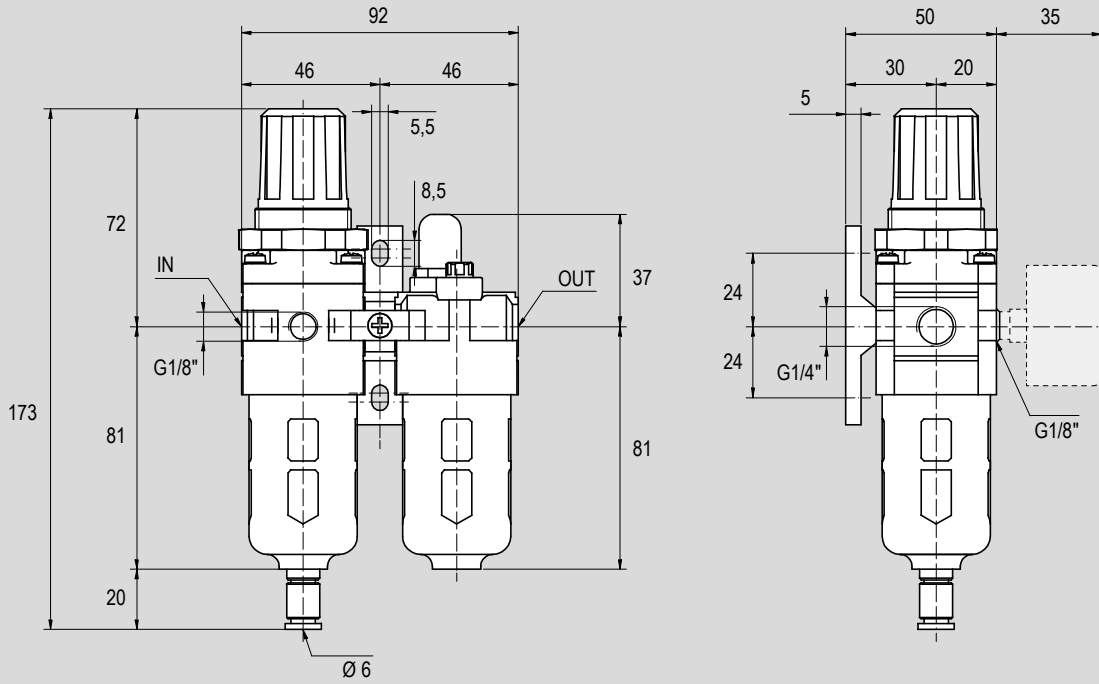

3 - AIR TREATMENT

Size	Function	Symbol	Code	Item
1/4"	Filter-regulator + lubricator		090100	A14FRRL

Standard dimensions

Type: **A38FRRL**

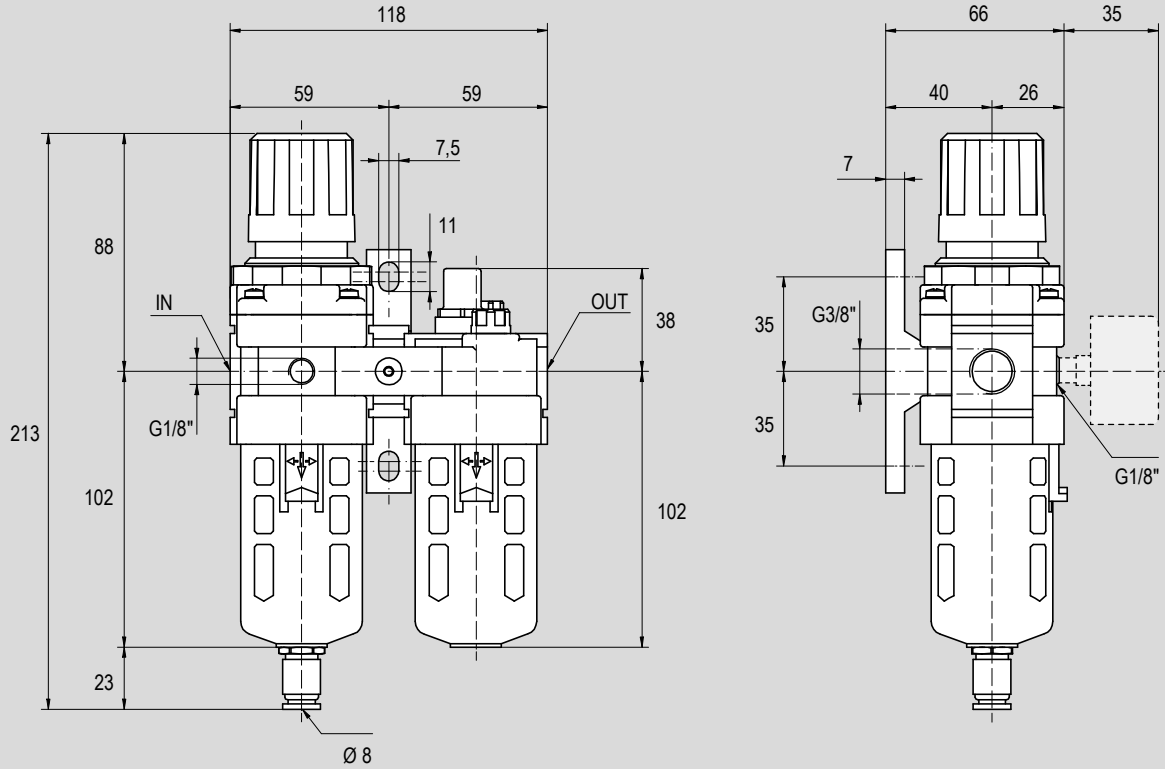

Size	Function	Symbol	Code	Item
3/8"	Filter-regulator + lubricator		090105	A38FRRL

Standard dimensions

Type: A12FRRL

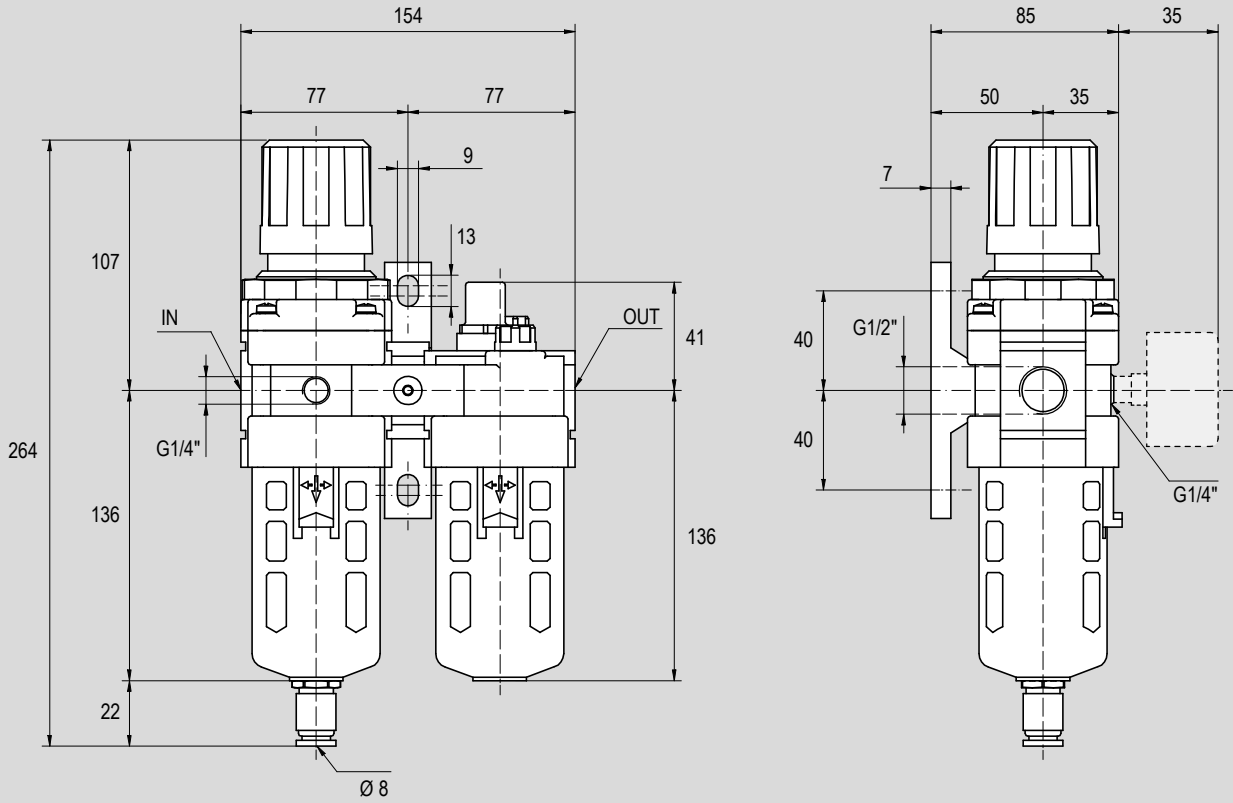

3 - AIR TREATMENT

Size	Function	Symbol	Code	Item
1/2"	Filter-regulator + lubricator		090110	A12FRRL



Standard dimensions

Type: A01FRRL

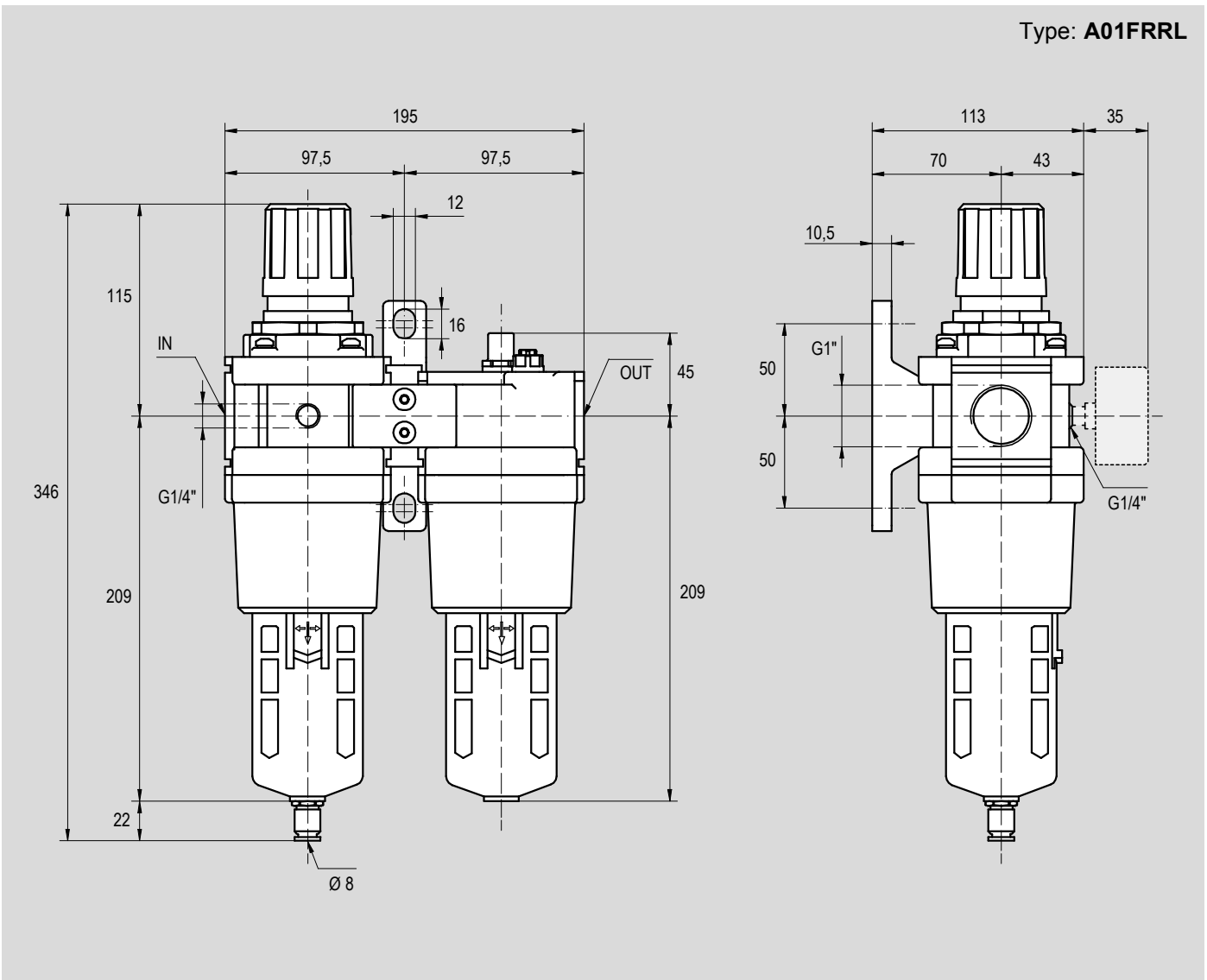

Size	Function	Symbol	Code	Item
1"	Filter-regulator + lubricator		090115	A01FRRL

3 - AIR TREATMENT

# Modular units

Soft-start solenoid operated valves, 1/4" ÷ 1/2"



## Main features

Code	Item	Size	Function	Symbol
090231	AVP14E	1/4"	Soft-start solenoid operated valves	
090232	AVP38E	3/8"		
090233	AVP12E	1/2"		



## Technical data

Type	AVP14E	AVP38E	AVP12E
Size	1/4"	3/8"	1/2"
Fluid	Compressed air		
Maximum inlet pressure	15 bar		
Minimum piloting pressure	0,2 bar		
Pressure range	0,3 ÷ 10 bar		
Temperature range	0°C ÷ +60°C		
Section	1 (P) → 2 (A)	20 mm <sup>2</sup>	61 mm <sup>2</sup>
	2 (A) → 3 (R)	24 mm <sup>2</sup>	76 mm <sup>2</sup>
Gauges port	1/8"		
Plunger	9 mm		
Manual override	Spring return		

## Notes

Spacers and mounting brackets to be ordered separately, see page 3.2.300  
 Pressure-gauges to be ordered separately, see from page 3.30.1  
 Coils and connectors to be ordered separately, see page 2.315.1

### Operating conditions

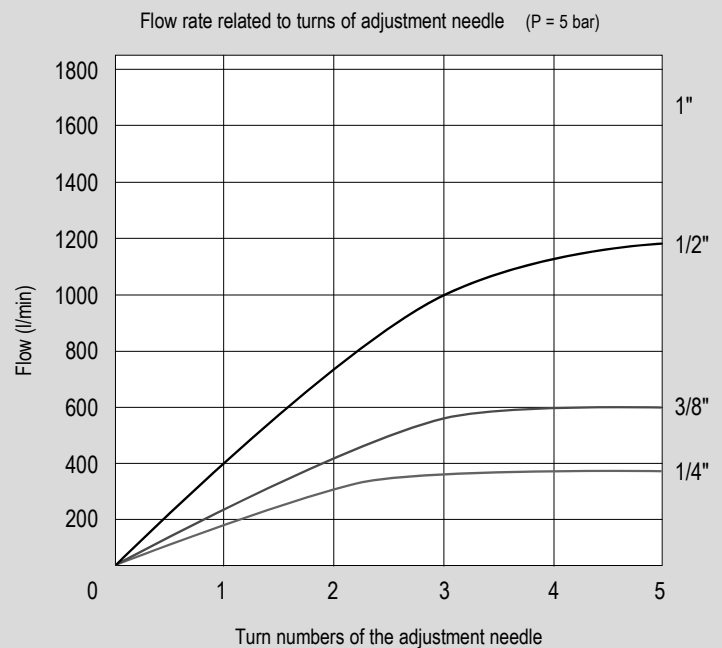
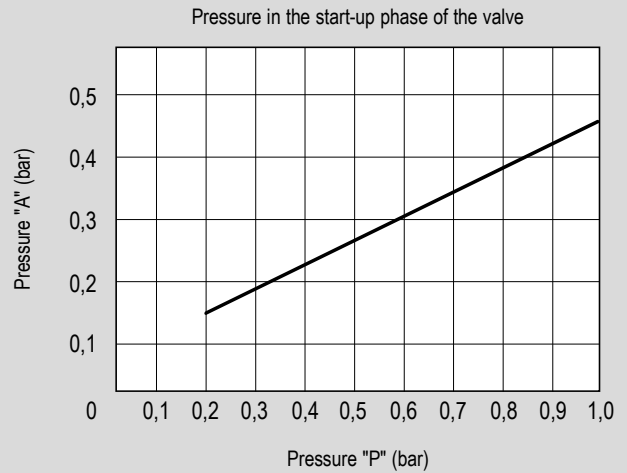
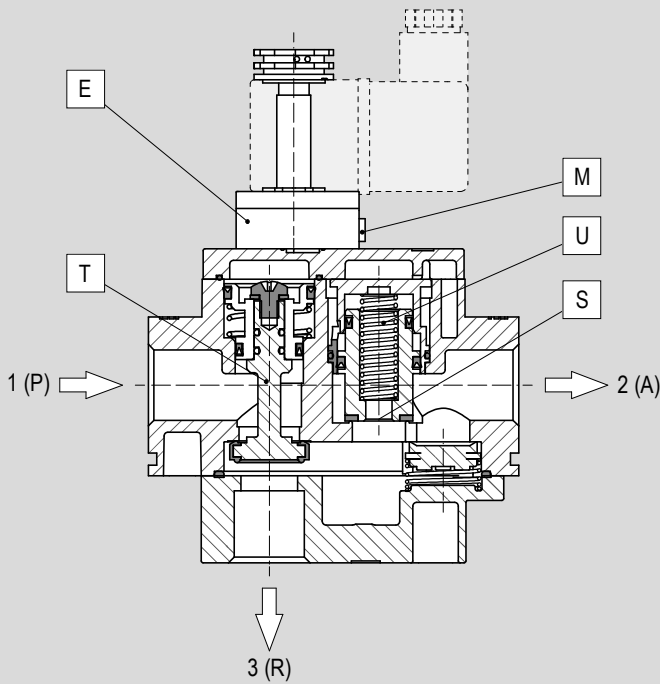

#### Start-up phase

By actuating the electro-pilot E, or pushing the manual override M, air will push the poppet T down opening this way the main power valve and at the same time, closing the exhaust (R). Air from inlet (P) will go through the regulation needle S and then to the outlet (A). Opening speed can be adjustable by the side screw.

#### Switching and working phase

In the moment the pressure difference between (A) and (P) is  $(A) \geq \frac{1}{2} (P)$ , the poppet U fully open and outlet pressure (A) rapidly increase until equalize inlet pressure in (P). Soft-start valve will not represent any obstacle for the air-flow going through it.

#### Closing and exhausting phase

By deactivating electro-pilot E, or releasing the manual override M, the poppet T will reposition stopping the air from inlet (P) and contemporary exhaust the downstream air in the circuit from the exhaust (R).

# Modular units

Soft-start solenoid operated valves, 1/4" ÷ 1/2"



## Standard dimensions

Type: AVP..E

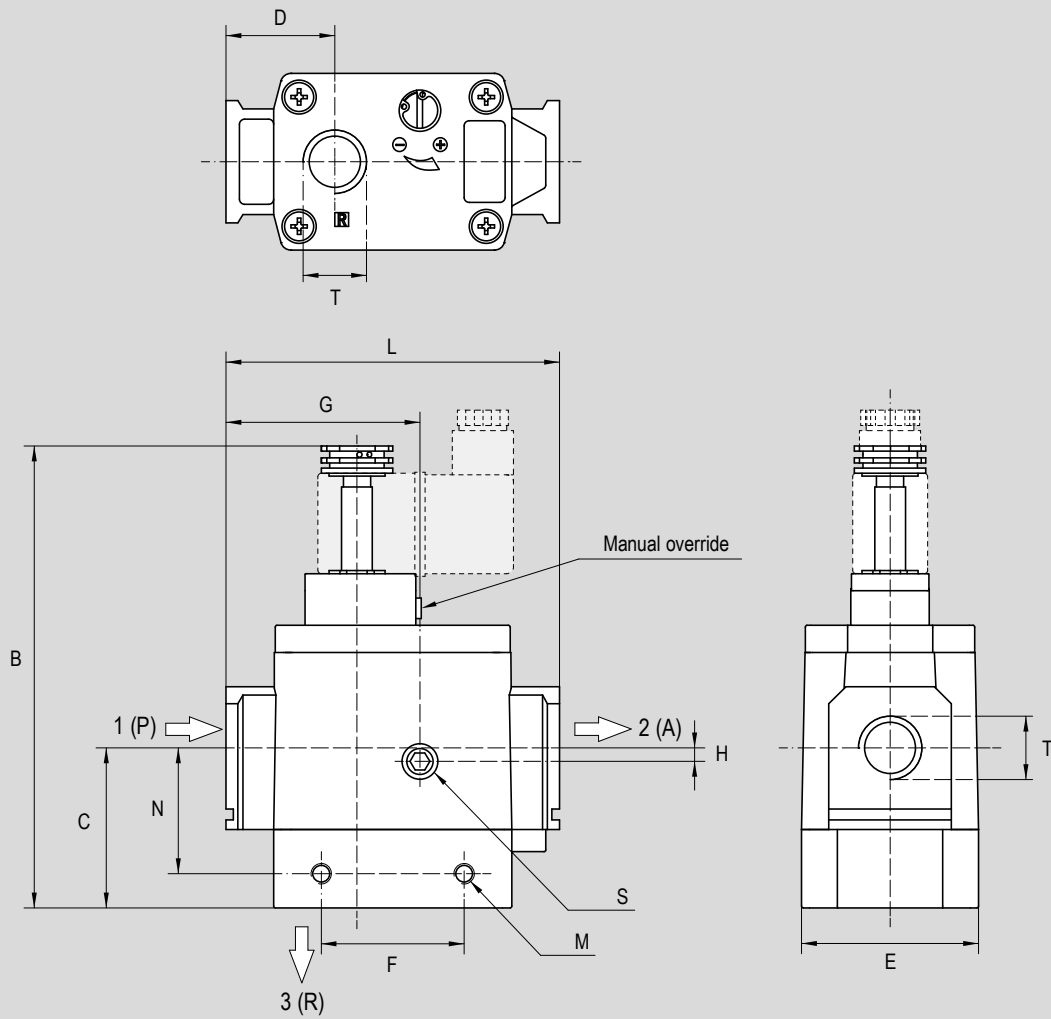

3 - AIR TREATMENT

Item	Code	Size	B	C	D	E	F	G	H	L	M	N	S	T
AVP14E	090231	1/4"	114	31	22	40	29	38	0	66	M4	23,5	G1/8"	G1/4"
AVP38E	090232	3/8"	131	36	24	48	28	43	2	76	M5	27,5	G1/8"	G3/8"
AVP12E	090233	1/2"	146	47	32	52	42	57	3	98	M6	42	G1/8"	G1/2"

# Modular units

Soft-start air operated valves, 1/4" ÷ 1/2"



## Main features

Code	Item	Size	Function	Symbol
090247	AVP14P	1/4"	Soft-start air operated valves	
090248	AVP38P	3/8"		
090249	AVP12P	1/2"		



## Technical data

Type	AVP14P	AVP38P	AVP12P
Size	1/4"	3/8"	1/2"
Fluid	Compressed air		
Maximum inlet pressure	15 bar		
Minimum piloting pressure	0,2 bar		
Pressure range	0,3 ÷ 10 bar		
Temperature range	0°C ÷ +60°C		
Section	1 (P) → 2 (A)	20 mm <sup>2</sup>	37 mm <sup>2</sup>
	2 (A) → 3 (R)	24 mm <sup>2</sup>	49 mm <sup>2</sup>
Gauges port	1/8"		

## Notes

Spacers and mounting brackets to be ordered separately, see page 3.2.300

Operating conditions

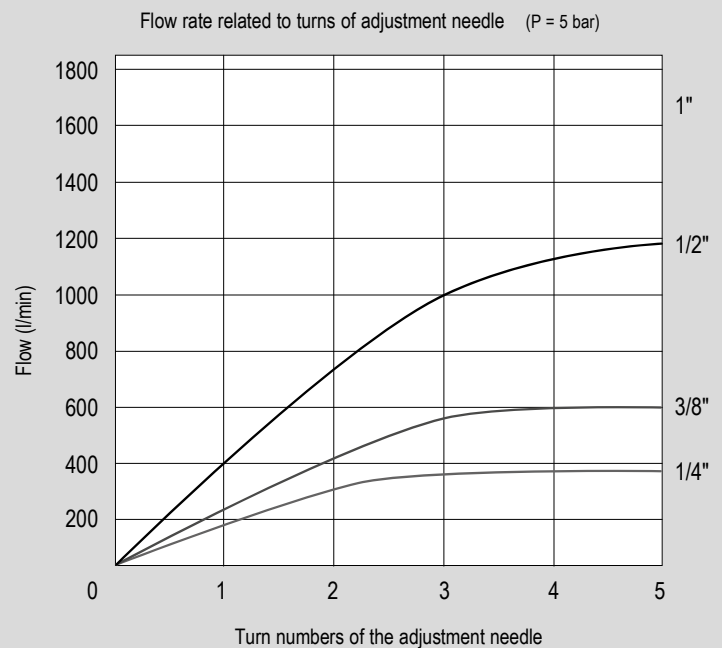
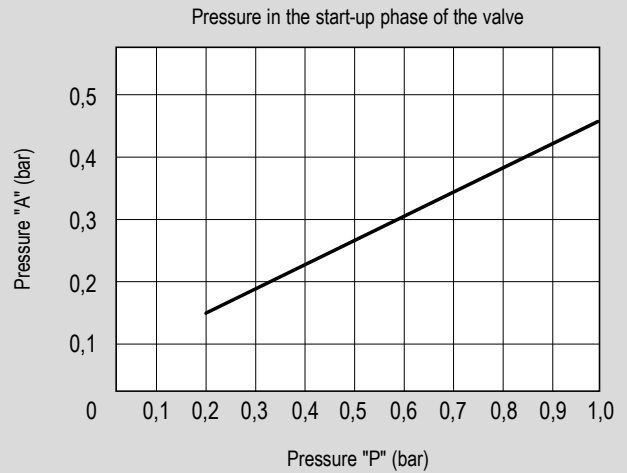
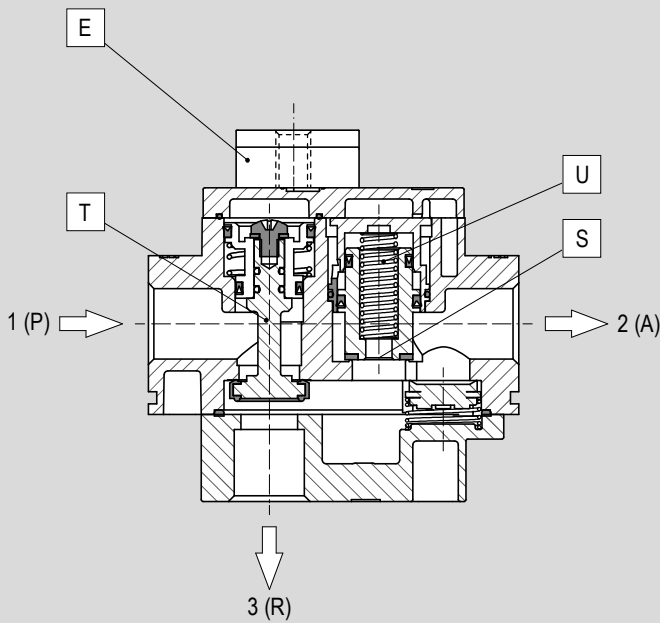

**Start-up phase**

By actuating the pneumatic-pilot E air will push the poppet T down opening this way the main power valve and at the same time, closing the exhaust (R). Air from inlet (P) will go through the regulation needle S and then to the outlet (A). Opening speed can be adjustable by the side screw.

**Switching and working phase**

In the moment the pressure difference between (A) and (P) is  $(A) \geq \frac{1}{2} (P)$ , the poppet U fully open and outlet pressure (A) rapidly increase until equalize inlet pressure in (P). Soft-start valve will not represent any obstacle for the air-flow going through it.

**Closing and exhausting phase**

By deactivating pneumatic-pilot E the poppet T will reposition stopping the air from inlet (P) and contemporary exhaust the downstream air in the circuit from the exhaust (R).

# Modular units

Soft-start air operated valves, 1/4" ÷ 1/2"



## Standard dimensions

Type: AVP..P

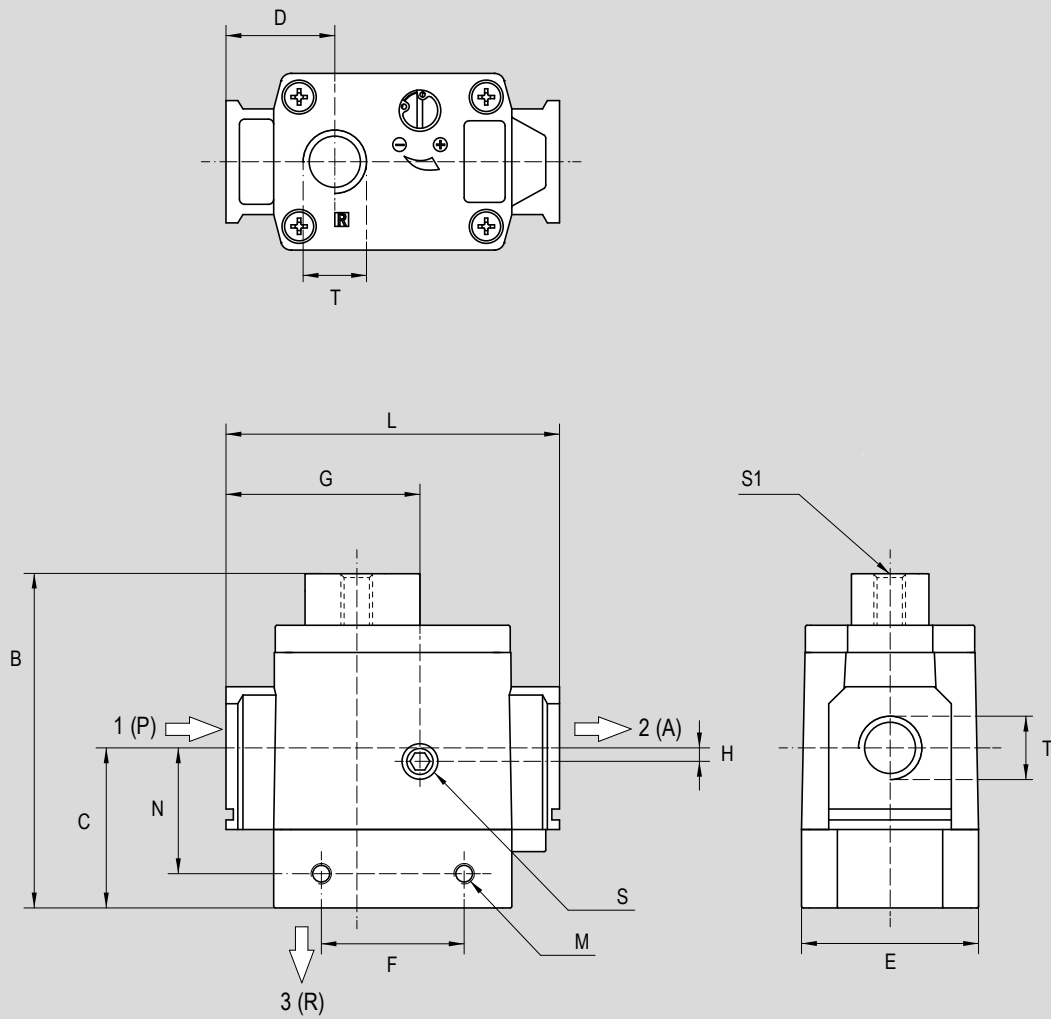





Item	Code	Size	B	C	D	E	F	G	H	L	M	N	S	S <sub>1</sub>	T
AVP14P	090247	1/4"	75	31	22	40	29	38	0	66	M4	23,5	G1/8"	G1/8"	G1/4"
AVP38P	090248	3/8"	82	36	24	48	28	43	2	76	M5	27,5	G1/8"	G1/8"	G3/8"
AVP12P	090249	1/2"	97	47	32	52	42	57	3	98	M6	42	G1/8"	G1/8"	G1/2"

## Modular units

Exhaust manual operated valves, 1/4" ÷ 1"



### Main features

Code	Item	Size	Function	Symbol
090152	 VMS14	1/4"	Exhaust manual operated valve	
090153	 VMS38	3/8"		
090154	 VMS12	1/2"		
090265	VMS01	1"		



### Technical data

Type	VMS14	VMS38	VMS12	VMS01
Size	1/4"	3/8"	1/2"	1"
Fluid	Compressed air			
Pressure range	0 ÷ 10 bar			
Temperature range	-5°C ÷ +60°C			
Connections	1/4"	3/8"	1/2"	1"
Exhaust	1/8"	1/4"	3/8"	1/2"
Safety	Lockable			

### Notes

Spacers and mounting brackets to be ordered separately, see page 3.2.300



# Modular units

Exhaust manual operated valves, 1/4" ÷ 1"



## Standard dimensions

Type: **VMS**

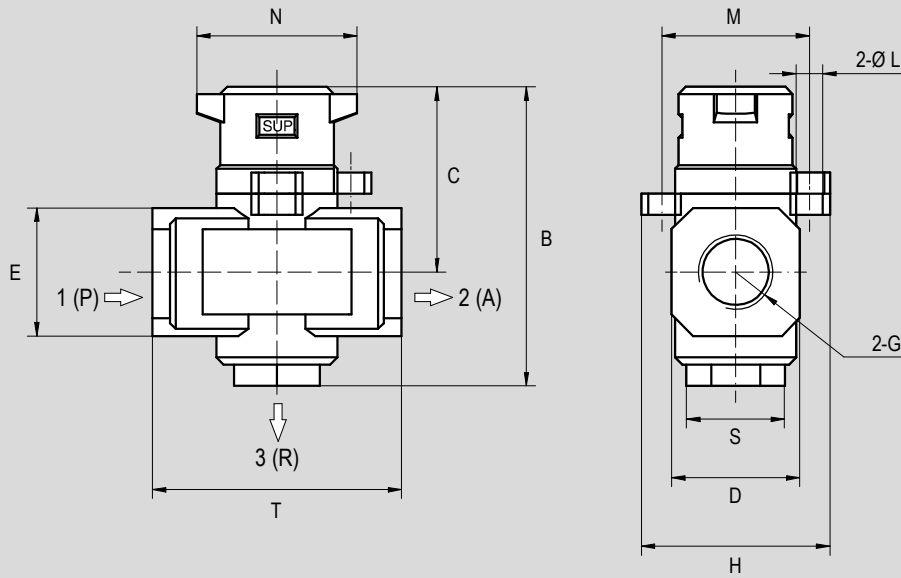

Item	Code	Size	G	S	T	B	C	D	E	H	ØL	M	N
VSM14	090152	1/4"	G1/4"	G1/8"	40	59	39	28	22	41	6	32	40
VSM38	090153	3/8"	G3/8"	G1/4"	53	78	49	30	28	53	7,5	41,5	45
VSM12	090154	1/2"	G1/2"	G3/8"	70	84	52	36	36	53	7,5	41,5	45
VSM01	090265	1"	G1"	G1/2"	90	136	72	54	48	90	8,5	77	68

Spacer, D..

	Size	Code	Item	Matching
	1/4"	090148	D14	A..FRRL A..FRR
	3/8"	090149	D38	A..F.. A..R..
	1/2"	090150	D12	A..L.. AVP..
	1"	090151	D01	VMS..

Spacer with "T" type porting block, DT..

	Size	Code	Item	Matching
	1/4"	090129	DT14	A..FRRL*
	3/8"	090130	DT38	A..F.. A..R..
	1/2"	090131	DT12	A..L.. AVP..
	1"	090132	DT01	VMS..

\*To be applied exclusively on the "out" port

Spacer with "L" type bracket, DSL..

	Size	Code	Item	Matching
	1/4"	090133	DSL14	A..FRRL A..FRR
	3/8"	090134	DSL38	A..F.. A..R..
	1/2"	090135	DSL12	A..L.. AVP..
	1"	090136	DSL01	VMS..

Spacer with "T" type bracket, DST..

	Size	Code	Item	Matching
	1/4"	090137	DST14	A..FRRL*
	3/8"	090138	DST38	A..FRR A..F.. A..R..
	1/2"	090139	DST12	A..L.. AVP..
	1"	090140	DST01	VMS..

\*Supplied as standard

Mounting bracket for regulator and filter-regulator, SR..

	Size	Code	Item	Matching
	1/4"	090141	SR14	A..FRRL A..FRR A..R
	3/8"	090142	SR38	
	1/2"	090143	SR1201	
	1"			

Mounting bracket for filter and lubricator, SFL..

	Size	Code	Item	Matching
	1/4"	090144	SFL14	A..F A..L
	3/8"	090145	SFL38	
	1/2"	090146	SFL12	
	1"	090147	SFL01	

Mounting bracket for precision regulator, SRP..

	Size	Code	Item	Matching
	1/8"	090315	SRP18	A..RP
	1/4"	090316	SRP14	
	1/2"	090317	SRP12	

Slide valves V26..

	Size	Code	Item	Matching
	1/4"	030703	V260014	A..FRRL A..FRR
	3/8"	030704	V260038	A..F.. A..R..
	1/2"	030705	V260012	A..L..

Coils ASA12..

	Voltage	Code	Item	Matching
	12V DC	032100	ASA1201200	AVP..E
	12V AC	032101	ASA1201250	
	24V DC	032102	ASA1202400	
	24V AC	032103	ASA1202450	
	48V AC	032104	ASA1204850	
	110V AC	032105	ASA1211050	
	230V AC	032106	ASA1223050	

Connectors A122..\*

	Code	Item	Type
	032118	A12209N	Black standard
	033521	A12209NK	Black standard cabled
	032204	A12209T1	LED+VDR transparent 24VAC-DC
	032205	A12209T2	LED+VDR transparent 115VAC-DC
	032206	A12209T3	LED+VDR transparent 230VAC-DC
	033522	A12209N1K	LED+VDR black cabled 24VAC-DC
	033523	A12209N2K	LED+VDR black cabled 115VAC-DC
	033524	A12209N3K	LED+VDR black cabled 230VAC-DC

\* For coils type ASA12

Main features

Type	Description
TP..F	Polycarbonate cup with metal protection, for filter. Compatible with types FRRL, FRR, F and FD.

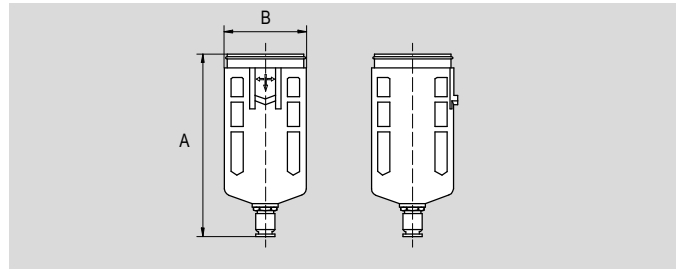

Dimensions

Size	Code	Item	A	B
1/4"	090155	TP14F	92	36
3/8"	090156	TP38F	114	44
1/2"	090157	TP12/01/112/200F	140	60
1"				

Main features

Type	Description
TM..F	Metal cup for filter. Compatible with types FRRL, FRR, F and FD.

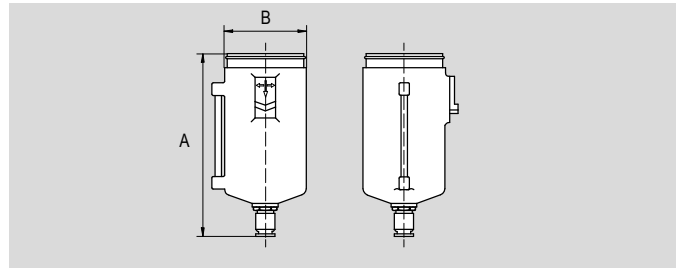

Dimensions

Size	Code	Item	A	B
1/4"	090121	TM14F	92	36
3/8"	090122	TM38F	114	44
1/2"	090123	TM12/01/112/200F	140	60
1"				

Main features

Type	Description
TP..L	Polycarbonate cup with metal protection, for lubricator. Compatible with types FRRL and L.

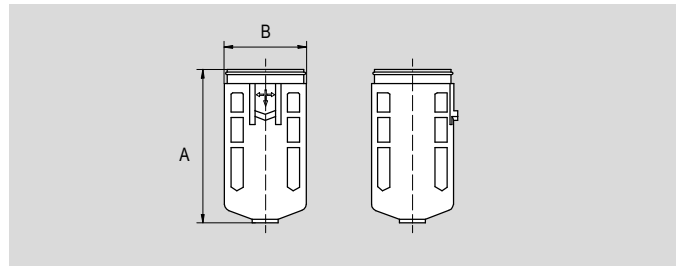

Dimensions

Size	Code	Item	A	B
1/4"	090159	TP14L	72	36
3/8"	090160	TP38L	90	44
1/2"	090161	TP12/01/112/200L	118	60
1"				

## Main features

Type	Description
TM..L	Metal cup for lubricator. Compatible with types FRRL and L.

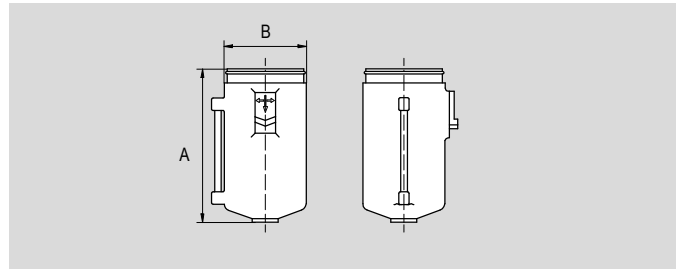

## Dimensions

Size	Code	Item	A	B
1/4"	090125	TM14L	72	36
3/8"	090126	TM38L	90	44
1/2"	090127	TM12/01/112/200L	118	60
1"				

## Sintered bronze standard filter cartridge 25 µm, CA../25

	Size	Code	Item	Matching
	1/4"	090171	CA14/25	FRRL FRR F
	3/8"	090172	CA38/25	
	1/2"	090173	CA12/25	
	1"	090174	CA01/25	

## Plastic filter cartridge 5 µm, CA../5

	Size	Code	Item	Matching
	1/4"	090175	CA14/5	FRRL FRR F
	3/8"	090176	CA38/5	
	1/2"	090177	CA12/5	
	1"	090178	CA01/5	

## Plastic filter cartridge 0,3 µm, CA../03

	Size	Code	Item	Matching
	3/8"	090281	CA38/03	FD
	1/2"	090282	CA12/03	
	1"	090283	CA01/03	

## Diaphragm for regulators, DF

	Size	Code	Item	Matching
	1/4"	090179	DF14	FRRL FRR R
	3/8"	090180	DF38	
	1/2"	090181	DF12	
	1"	090182	DF01	

## Cup seals kit, ORT..

	Size	Code	Item	Matching
	1/4"	090187	ORT14	FRRL FRR F FD L
	3/8"	090188	ORT38	
	1/2"	090189	ORT12/01/112/200	
	1"			

## Oil regulation kit, OL..

	Size	Code	Item	Matching
	1/4"	090183	OL14	FRRL L
	3/8"	090184	OL38/12/01	
	1/2"			
	1"			

# F-R-L UNITS

1-1/2" and 2"



Find out our  
key products



**Solution for most applications**



**Easy and intuitive choice**



**Excellent value for money**



**Wide availability**



**Fast delivery**



## Main features and certifications

Aluminium air treatment units: filters (F), regulators (R) and lubricators (L) available in sizes 1-1/2" and 2". The regulators are equipped with relieving valve. Polycarbonate cups with metal protection.  
 Supplied as standard in compliance to Reach and RoHS directives, and SIL certified.  
 Pressure-gauges to be ordered separately.



## Filters series A..F, 1-1/2" and 2"

from page 3.6.20



Aluminium filters available in sizes 1-1/2" and 2". Equipped with 25µm filtering element and semi-automatic condense drain. The polycarbonate cup is with metal protection.  
 Spare parts available for filter, cup and cup seals.



## Regulators series A..R, 1-1/2" and 2"

from page 3.6.50



Aluminium regulators available in sizes 1-1/2" and 2". Equipped with relieving valve and practical plastic regulation knob.  
 Pressure-gauges to be ordered separately.



## Lubricators series A..L, 1-1/2" and 2"

from page 3.6.80



Aluminium lubricators available in sizes 1-1/2" and 2". Equipped with oil regulation cup, and polycarbonate cup with metal protection. The lubricant can be added without stopping the air supply.  
 Spare parts available for oil regulation cup, cup and cup seals.



Options		
Description	Symbol	Suffix
Filter cartridge 5 µm		<b>5</b>
Automatic condense drain		<b>SA</b>
Metal cup		<b>TM</b>
NPT thread		<b>NPT</b>

The options, when this is possible, can be combined with each other. For options matching see the table below; For code key see from page 3.6.4

Options matching						
Type	Size	Model	Standard options matching			
			<b>5</b>	<b>SA</b>	<b>TM</b>	<b>NPT</b>
A..F	1 1/2" - 2"	Standard	●	●	●	●
		Filter cartridge 5 µm (5)		●	●	●
		Automatic condense drain (SA)	●		●	●
		Metal cup (TM)	●	●		●
A..R	1 1/2" - 2"	Standard	-	-	-	●
A..L	1 1/2" - 2"	Standard	-	-	●	●
		Metal cup (TM)	-	-		●

Key  
 ● allowed matching; - not allowed matching

Code key

Series	Size	Function	Options <sup>(1)</sup>			
<b>A</b>	<b>112</b>	<b>F</b>	●	●	<b>TM</b>	●
A	112 = 1 1/2"  200 = 2"	F = Filter  R = Regulator  L = Lubricator	5	SA	TM	NPT

How to order

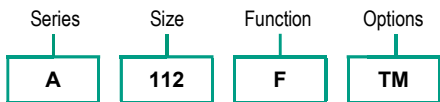

Notes

For standard materials see table at page 3.6.5  
 Options in the same grid are alternative to each others.  
 (1) For further information on options and their matching see page 3.6.3



Standard materials for filters, regulators and lubricators

Type: A..F

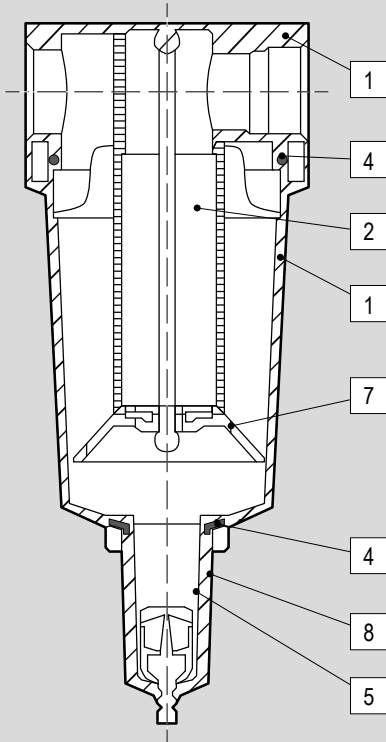

Type: A..R

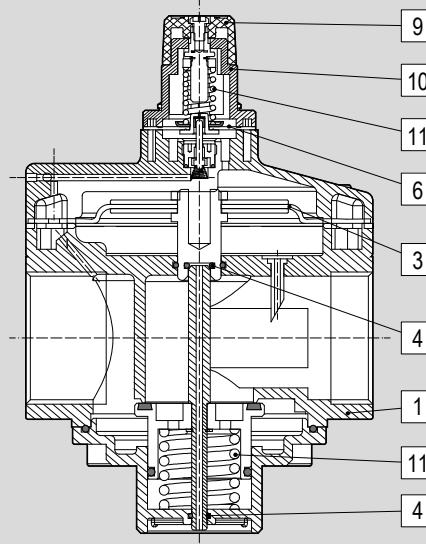

Type: A..L

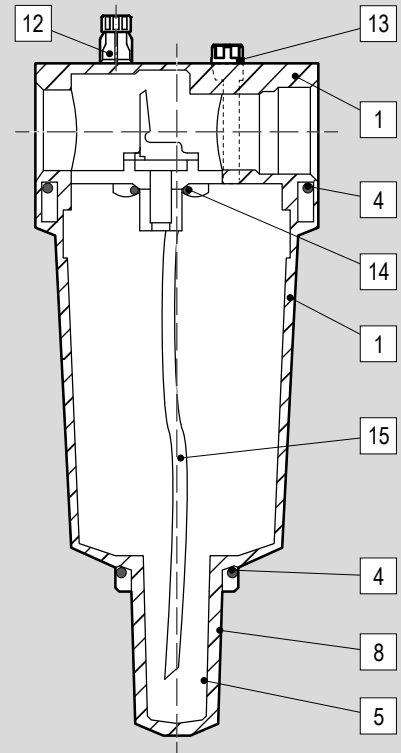

Position	Description	Material		
		A..F	A..R	A..L
1	Body	Die-cast aluminium		
2	Filtering element	Sintered bronze	-	
3	Main valve diaphragm	-	NBR	-
4	Seal	NBR		
5	Cup	Polycarbonate	-	Polycarbonate
6	Diaphragm	-	NBR	-
7	Diaphragm holder	Carbon steel		
8	Cup protection	Painted aluminium	-	Painted aluminium
9	Knob	-	Reinforced nylon	-
10	Cover	-	Die-cast aluminium	-
11	Spring	-	Spring steel	-
12	Sight-glass	-	-	Polycarbonate
13	Needle valve assembly	-	-	Steel / Polymer
14	Nut seal	-	-	NBR
15	Syphon pipe	-	-	Polymer

Accessories

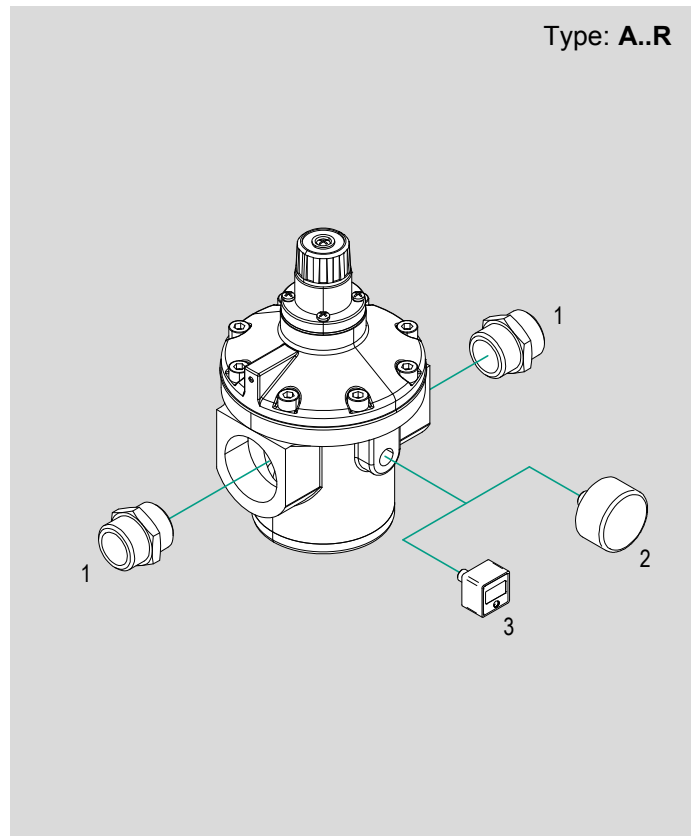
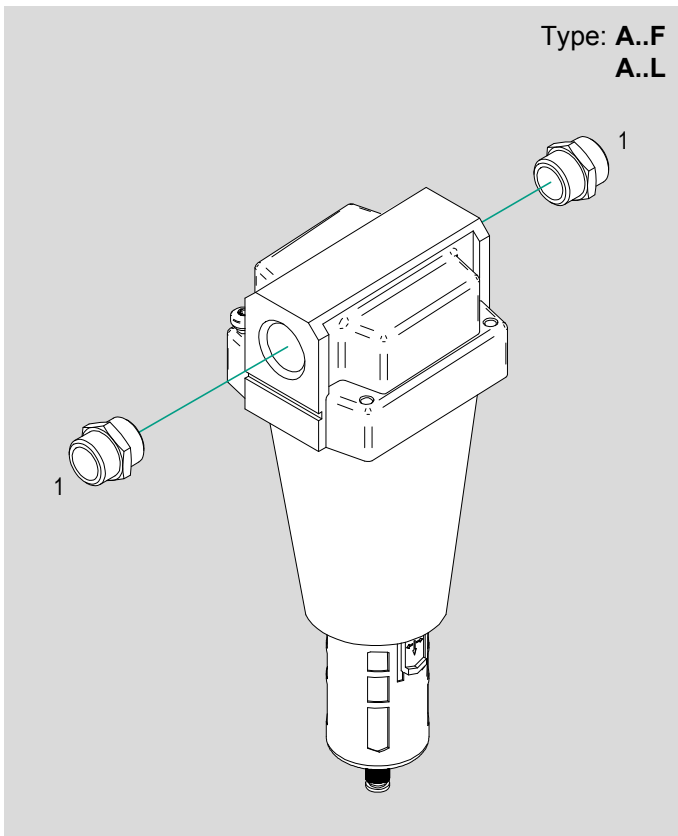

N.	Size	Item	Description	Matching			Code key and data sheet page
				A..F	A..R	A..L	
1	1 1/2" ÷ 2"	A..	BSP nipple male/male	●	●	●	4.35.1
2	1 1/2" ÷ 2"	M..	Analogic pressure-gauges	-	●	-	3.30.20
3	1 1/2" ÷ 2"	AKP60P..	Digital pressure-gauges	-	●	-	3.30.40

Key

● matching accessory; - not matching accessory

# F-R-L units, 1-1/2" and 2" Filters



## Main features

Code	Item	Size	Function	Symbol
090284	A112F	1 1/2"	Filter	
090287	A200F	2"		



## Technical data

Type	A112F	A200F
Size	1 1/2"	2"
Fluid	Compressed air	
Maximum inlet pressure	10 bar	
Temperature range	+5°C ÷ +60°C	
Flow (at 6 bar)	11500 NI/min.	18500 NI/min.
Filtering element	25 µm (standard)	5 µm (5)
Cup capacity	1800 cm <sup>3</sup>	
Condense drain	Semi-automatic (standard)	Automatic (SA)
Weight	3080 g	5160 g

## Notes

For nipples and connection elements with other components, see from page 4.35.1  
 For spare parts see from page 3.6.200

Standard dimensions

Type: A..F

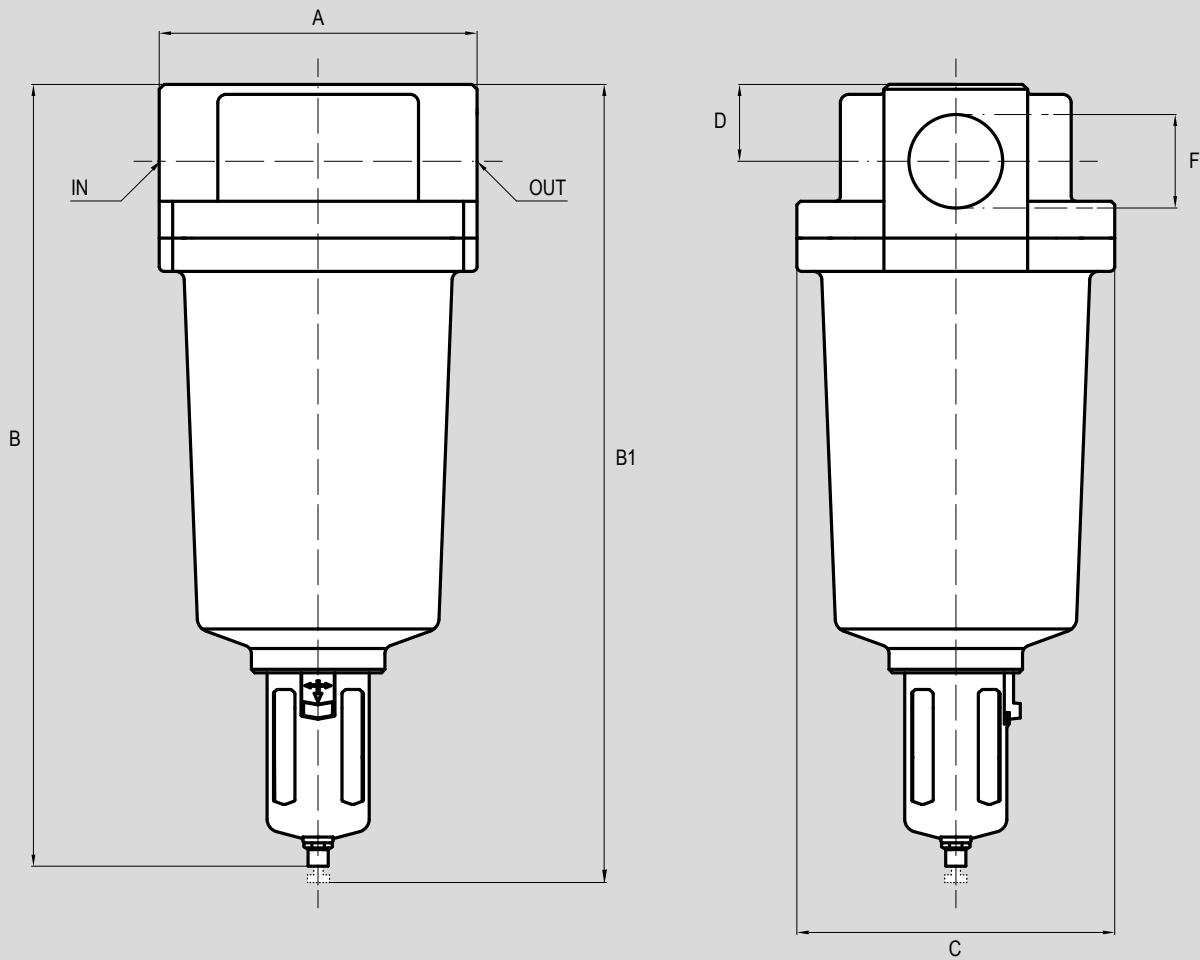

3 - AIR TREATMENT

Item	Code	Size	Function	Symbol	A	B	B1*	C	D	F
A112F	090284	1 1/2"	Filter		150	390	394,5	140	33	G1 1/2"
A200F	090287	2"			190	470	474,5	190	46	G2"

\* = With automatic condensate drain option (SA)

# F-R-L units, 1-1/2" and 2" Regulators



## Main features

Code	Item	Size	Function	Symbol
090285	A112R	1 1/2"	Regulator	
090288	A200R	2"		



## Technical data

Type	A112R	A200R
Size	1 1/2"	2"
Fluid	Compressed air	
Maximum inlet pressure	10 bar	
Pressure regulation range	0,5 ÷ 8,5	
Temperature range	+5°C ÷ +60°C	
Flow (at 6 bar)	18000 NI/min.	22000 NI/min.
Pressure regulator	Diaphragm	
Overpressure relief	Relieving	
Gauges port	1/4"	
Weight	2500 g	3100 g

## Notes

For nipples and connection elements with other components, see from page 4.35.1  
Pressure-gauges to be ordered separately, see from page 3.30.1

Standard dimensions

Type: A..R

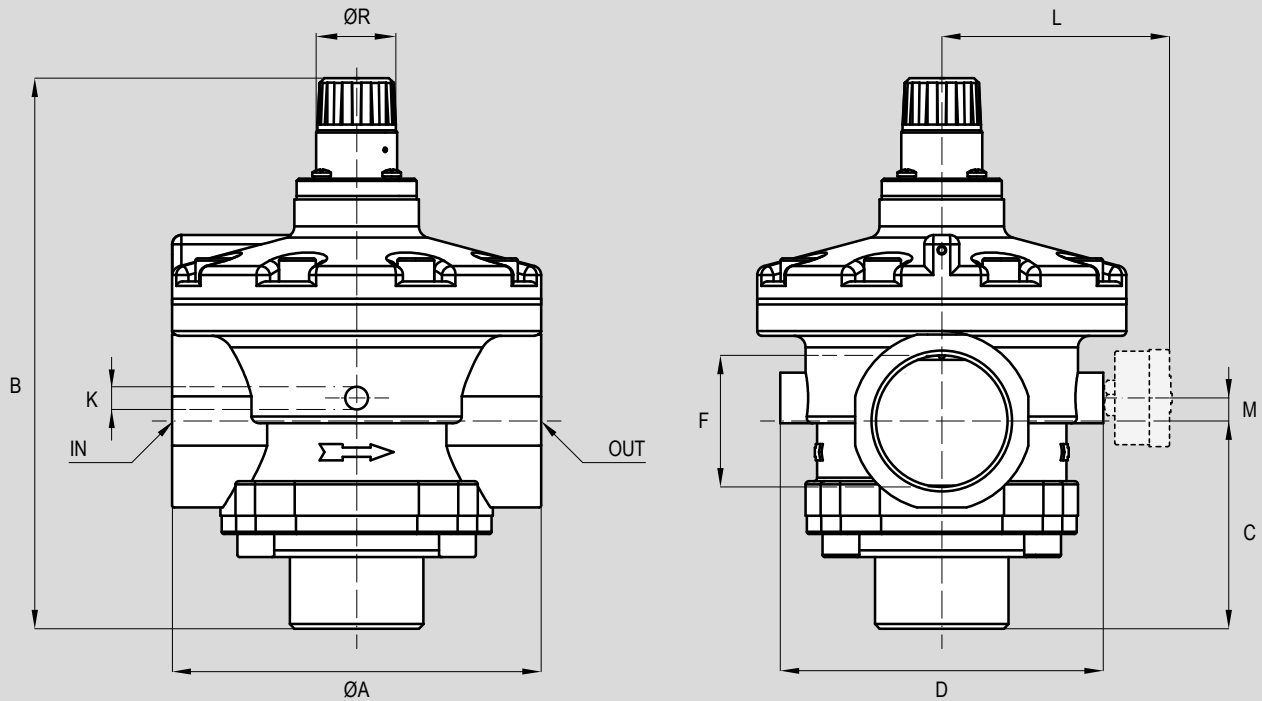

3 - AIR TREATMENT

Item	Code	Size	Function	Symbol	ØA	B	C	D	F	K	L	M	ØR
A112R	090285	1 1/2"	Regulator		126	216	75	110	G1 1/2"	G1/4"	90,5	5	34
A200R	090288	2"			160	242	90	140	G2"	G1/4"	105,5	10	34

# F-R-L units, 1-1/2" and 2"

## Lubricators



### Main features

Code	Item	Size	Function	Symbol
090286	A112L	1 1/2"	Lubricator	
090289	A200L	2"		



### Technical data

Type	A112L	A200L
Size	1 1/2"	2"
Fluid	Compressed air	
Maximum inlet pressure	10 bar	
Temperature range	+5°C ÷ +60°C	
Minimum flow for lubrication (at 5 bar)	1000 l/min.	
Cup capacity	1600 cm <sup>3</sup>	
Suggested lubricant	With viscosity ISO VG 32 compliant to ISO 3448 standards	
Weight	3140 g	3330 g

### Notes

For nipples and connection elements with other components, see from page 4.35.1  
 For spare parts see from page 3.6.200

Standard dimensions

Type: A..L

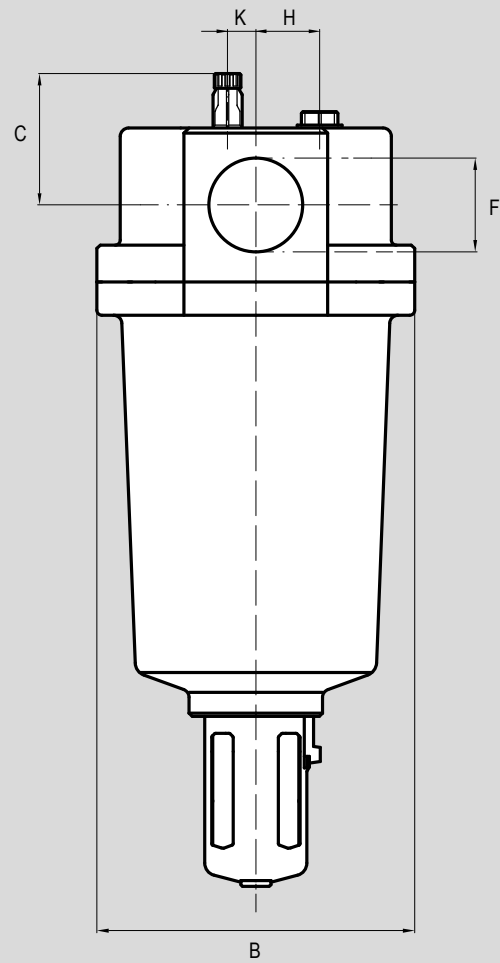
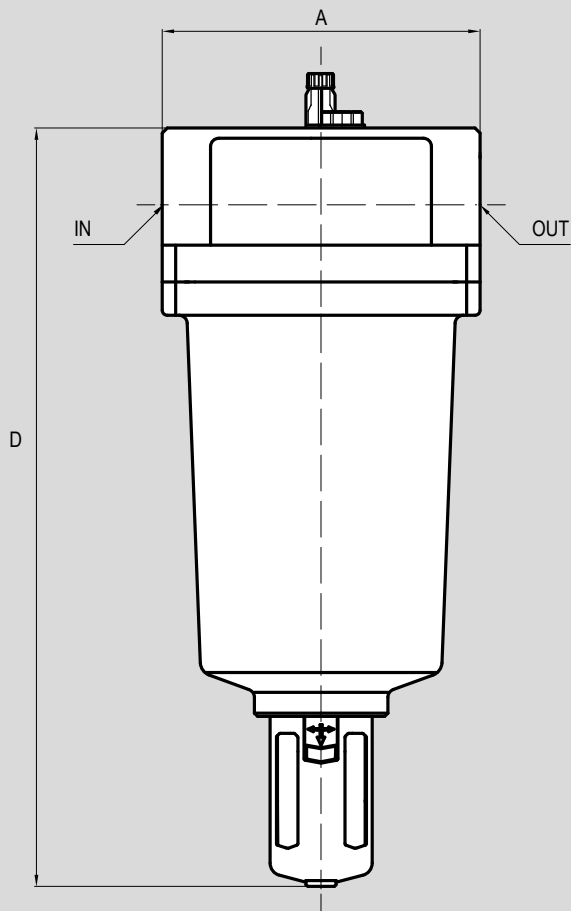

3 - AIR TREATMENT

Item	Code	Size	Function	Symbol	A	B	C	D	F	H	K
A112L	090286	1 1/2"	Lubricator		150	140	71	410	G1 1/2"	40	15,5
A200L	090289	2"							G2"		



Main features

Type	Description
TP..F	Polycarbonate cup with metal protection, for filter. Compatible with filters types F.

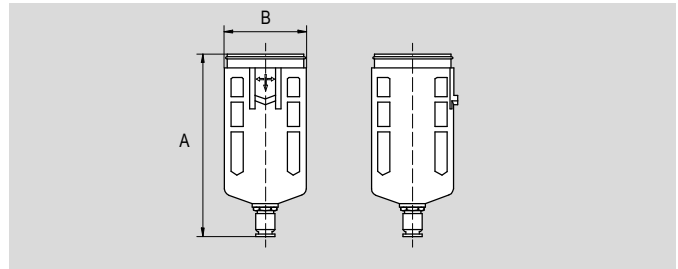

Dimensions

Size	Code	Item	A	B
1 1/2"	090157	TP12/01/112/200F	140	60
2"				

Main features

Type	Description
TM..F	Metal cup for filters. Compatible with filters types F.

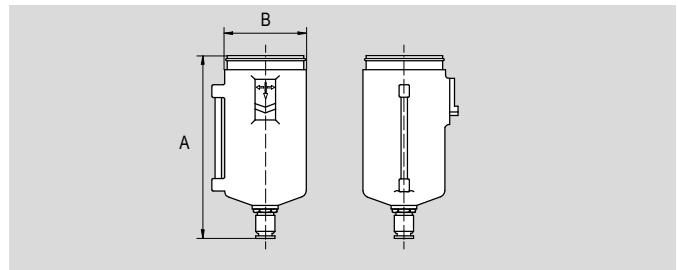

Dimensions

Size	Code	Item	A	B
1 1/2"	090123	TM12/01/112/200F	140	60
2"				

Main features

Type	Description
TP..L	Polycarbonate cup with metal protection, for lubricator. Compatible with lubricators types L.

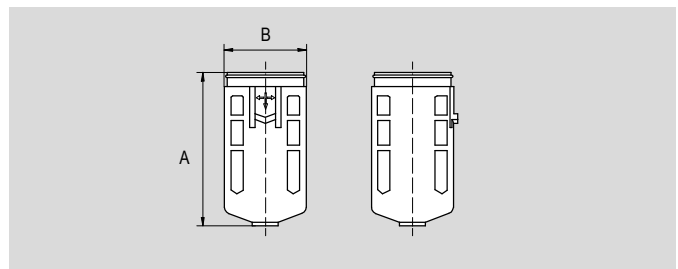

Dimensions

Size	Code	Item	A	B
1 1/2"	090161	TP12/01/112/200L	118	60
2"				

Main features

Type	Description
TM..L	Metal cup for lubricator. Compatible with lubricators types L.

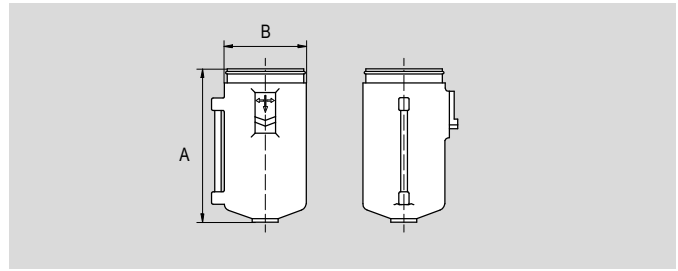

Dimensions

Size	Code	Item	A	B
1 1/2"	090127	TM12/01/112/200L	118	60
2"				

Sintered bronze standard filter cartridge 25 µm, CA../25

	Size	Code	Item	Matching
	1 1/2"	090290	CA112/25	F
	2"	090291	CA200/25	

Plastic filter cartridge 5 µm, CA../5

	Size	Code	Item	Matching
	1 1/2"	090292	CA112/5	F
	2"	090293	CA200/5	

Cup seals kit, ORT..

	Size	Code	Item	Matching
	1 1/2"	090189	ORT12/01/112/200	F L
	2"			

Oil regulation kit, OL..

	Size	Code	Item	Matching
	1 1/2"	090294	OL112/200	L
	2"			

# MICROREGULATORS



Find out our  
key products



**Solution for most applications**



**Easy and intuitive choice**



**Excellent value for money**



**Wide availability**



**Fast delivery**



## Main features and certifications

Components to reduce, regulate and maintain constant pressure in an industrial plant.  
Supplied as standard in compliance to Reach and RoHS directives.  
Pressure-gauges and mounting brackets to be ordered separately.



## Microregulators series AC700, 1/8" ÷ 1/4"

from page 3.10.10



Series of microregulators with compact design.  
Standard relieving with safety knob position lock.  
Mounting brackets and pressure-gauges to be ordered separately.



Code key

Series	Type		Size
<b>AC</b>	<b>700</b>	<b>-</b>	<b>14RR</b>

AC

700

14RR = 1/8"

---

14RR = 1/4"

How to order

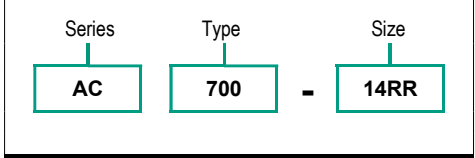

Notes

For standard materials see table below.  
 Options in the same grid are alternative to each others.  
 For pressure-gauges and mounting brackets, to be ordered separately, see from page 3.10.4

Standard materials

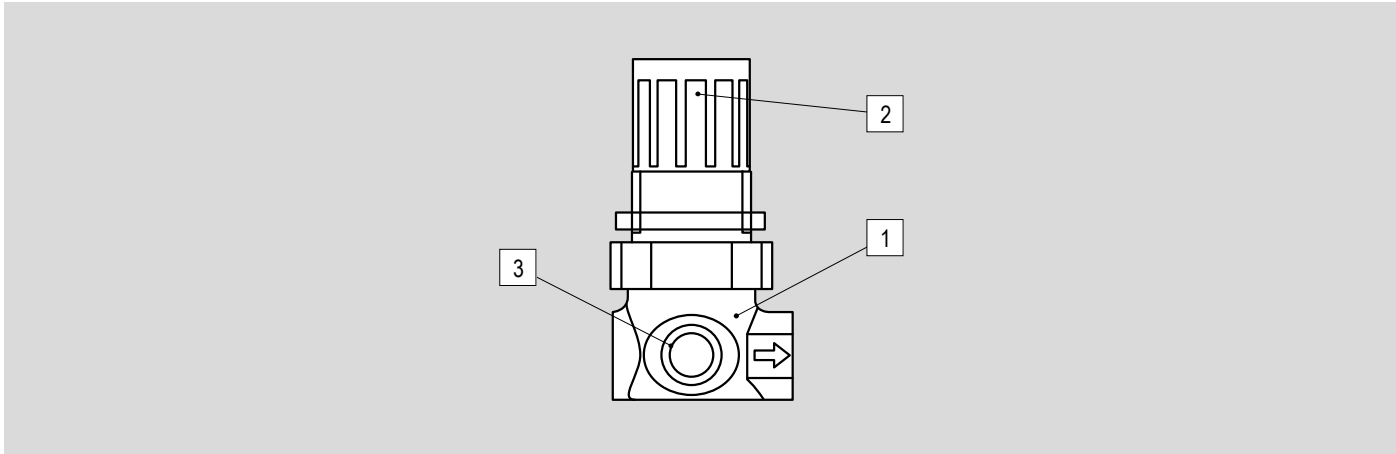

Position	Description	Material
1	Body	Black painted zinc
2	Knob	Acetalic resin
3	Seals	NBR

3 - AIR TREATMENT

Accessories

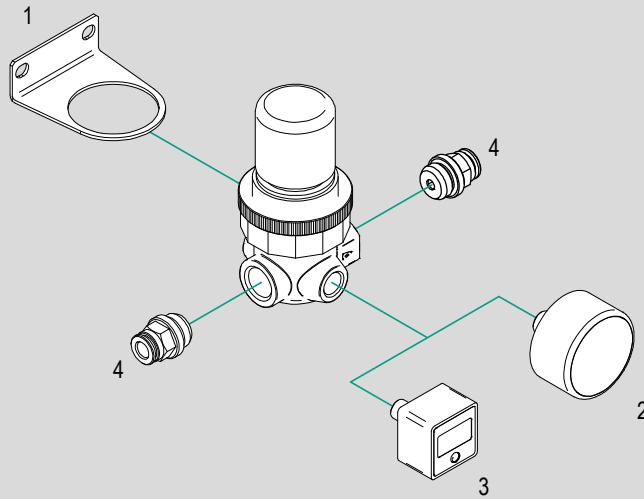

N.	Size	Item	Description	Matching	Code key page	Data sheet page
				AC700		
1	1/8" ÷ 1/4"	SR..	Mounting brackets	●	3.10.11	3.94.1
2	1/8" ÷ 1/4"	M..	Analogic pressure-gauges	●	3.30.20	
3	1/8" ÷ 1/4"	AKP60P..	Digital pressure-gauges	●	3.30.40	
4	1/8" ÷ 1/4"	R..	Push-in fittings	●	4.2.1	

Key

● matching accessory; - not matching accessory

3 - AIR TREATMENT

# Microregulators

Series AC700, 1/8" ÷ 1/4"



## Main features

Code	Item	Size	Function	Symbol
090307	AC700-1/8RR	1/8"	Microregulator	
090306	AC700-1/4RR	1/4"		



## Technical data

Type	AC700-1/8RR	AC700-1/4RR
Size	1/8"	1/4"
Fluid	Compressed air	
Maximum inlet pressure	15 bar	
Temperature range	+5°C ÷ +60°C	
Flow (at 6 bar)	390 NI/min.	420 NI/min.
Regulation range	0,5 ÷ 8,5 bar	

## Notes

Mounting brackets to be ordered separately, see page 3.10.90

Standard dimensions

Type: **AC700**

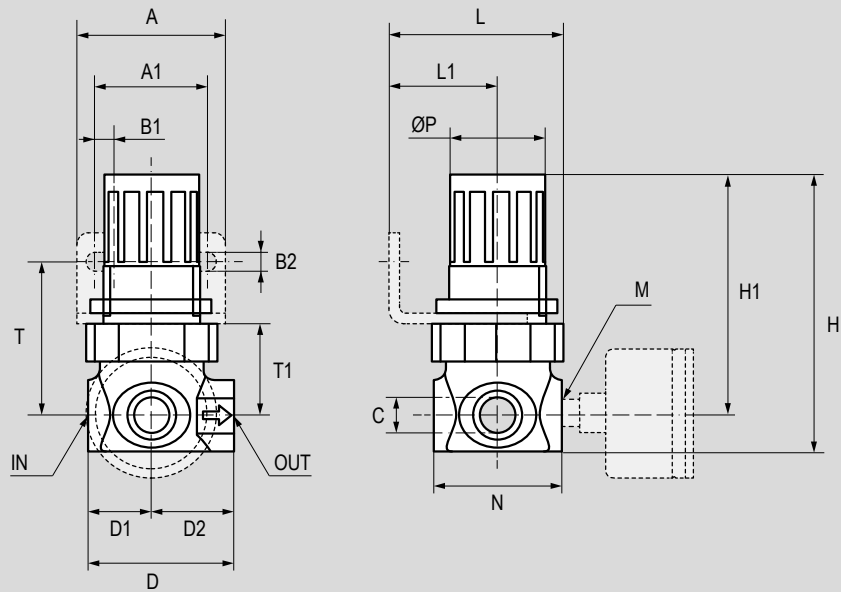

Item	Code	Size	A	A1	B1	B2	C	D	D1	D2	H	H1	L	L1	M	N	ØP	T	T1
AC700-1/8RR	090307	1/8"	36	30	6	6	G1/8"	41	19	23	75	64	54,5	35,5	G1/8"	38	28	36	24
AC700-1/4RR	090306	1/4"	36	30	6	6	G1/4"	41	19	23	75	64	54,5	35,5	G1/8"	38	28	36	24

3 - AIR TREATMENT

Accessories for microregulators

Mounting brackets for microregulator, SR..

	Size	Code	Item	Matching
	1/8"	090308	SR700	AC700
	1/4"			



# PRESSURE-GAUGES

vacuum-gauges and pressure switches



Find out our  
key products



Solution for most applications



Easy and intuitive choice



Excellent value for money



Wide availability



Fast delivery



## Main features and certifications

Analogic or digital pressure gauges, digital vacuum-gauges and pressure switches.  
 Supplied as standard in compliance to Reach and RoHS directives.  
 Mounting brackets to be ordered separately.



### Analogic pressure-gauges, series M

from page 3.30.20



"Dry" analogic pressure-gauges for pressure sensing in pneumatic systems, with rear connection. Available in three dial sizes (Ø 40, 50 and 63), 1/8" or 1/4" connections, in different scale (from -1÷0 bar up to 0÷12 bar).



### Analogic pressure-gauges, series MR

from page 3.30.20



"Dry" analogic pressure-gauges for pressure sensing in pneumatic systems, with in-line connection. Available in three dial sizes (Ø 40, 50 and 63), 1/8" or 1/4" connections, in different scale (from -1÷0 bar up to 0÷12 bar).



### Analogic pressure-gauges, series MF

from page 3.30.20



"Dry" analogic pressure-gauges for pressure sensing in pneumatic systems, with rear connection and flange. Available in three dial sizes (Ø 40, 50 and 63), 1/8" or 1/4" connections, in different scale (from -1÷0 bar up to 0÷12 bar).



### Analogic pressure-gauges, series MP

from page 3.30.20



"Dry" analogic pressure-gauges for pressure sensing in pneumatic systems, with rear connection and panel bracket. Available in three dial sizes (Ø 40, 50 and 63), 1/8" or 1/4" connections, in different scale (from -1÷0 bar up to 0÷12 bar).



### Digital pressure-gauges, series AKP60P

from page 3.30.40



Digital pressure-gauges for pressure sensing in pneumatic systems, with rear 1/8" or 1/4" connections, with these features: backlight; easy and fast reading; lithium battery power supply; quick and easy installation; 4 programmable pressure units (MPa, kgf/cm<sup>2</sup>, bar, psi) shown on display; power-saving mode; protection class IP65.



### Digital vacuum-gauges, series AKP60V

from page 3.30.40



Digital vacuum-gauges for vacuum sensing in pneumatic systems, with rear 1/8" or 1/4" connections, with these features: backlight; easy and fast reading; lithium battery power supply; quick and easy installation; 4 programmable pressure units (kPa, bar, psi, mmHG) shown on display; power-saving mode; protection class IP65.



### Digital pressure switches, series AKP43

from page 3.30.60



Digital pressure switches for instantaneous pressure display and also transmission of electrical signals, in positive pressure, vacuum and combined pressure versions. Available with 1/8" connection, PNP or NPN circuit, and these features: three color LCD display; backlight, easy and fast reading; 12÷24 VDC (±10%) power supply; 7 programmable pressure units (kPa, MPa, kgf/cm<sup>2</sup>, bar, psi, mmHG, inHg) shown on display.

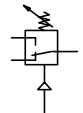

Analogic pressure-gauges code key

Series*	Dial Ø*	Connection*	Scale*
<b>M</b>	<b>50</b>	<b>B</b>	<b>0÷4</b>

M

---

MR

---

MF

---

MP

40 = Ø 40 mm

---

50 = Ø 50 mm

---

63 = Ø 63 mm

A = 1/8"

---

B = 1/4"

-1÷0 = -1 ÷ 0 bar

---

0÷2,5 = 0 ÷ 2,5 bar

---

0÷4 = 0 ÷ 4 bar

---

0÷6 = 0 ÷ 6 bar

---

0÷10 = 0 ÷ 10 bar

---

0÷12 = 0 ÷ 12 bar

**How to order**

Series	Dial Ø	Connection	Scale
<b>M</b>	<b>50</b>	<b>B</b>	<b>0÷4</b>

**Notes**

Options in the same grid are alternative to each others. For standard materials page 3.30.4

\*For matching between dial connection and scale, see the table below.

More versions available on request

Matching standard analogic pressure-gauges

Series	Dial size	Connection	Scale						See from page
			-1÷0 bar	0÷2,5 bar	0÷4 bar	0÷6 bar	0÷10 bar	0÷12 bar	
M..	Ø 40 mm	1/8"	●	●	●	●	●	●	3.30.21
		1/4"	-	-	-	-	-	-	
	Ø 50 mm	1/8"	●	●	●	●	●	●	
		1/4"	●	●	●	●	●	●	
	Ø 63 mm	1/8"	-	-	-	-	-	-	
		1/4"	●	●	●	●	●	●	
MR..	Ø 40 mm	1/8"	●	-	-	●	-	●	3.30.22
		1/4"	-	-	-	-	-	-	
	Ø 50 mm	1/8"	-	-	-	-	-	-	
		1/4"	●	-	-	●	-	●	
	Ø 63 mm	1/8"	-	-	-	-	-	-	
		1/4"	●	-	-	●	-	●	
MF..	Ø 40 mm	1/8"	●	-	-	●	-	●	3.30.23
		1/4"	-	-	-	-	-	-	
	Ø 50 mm	1/8"	●	-	-	●	-	●	
		1/4"	●	-	-	●	-	●	
	Ø 63 mm	1/8"	-	-	-	-	-	-	
		1/4"	●	-	-	●	-	●	
MP..	Ø 40 mm	1/8"	●	-	-	●	-	●	3.30.24
		1/4"	-	-	-	-	-	-	
	Ø 50 mm	1/8"	-	-	-	-	-	-	
		1/4"	●	-	-	●	-	●	
	Ø 63 mm	1/8"	-	-	-	-	-	-	
		1/4"	●	-	-	●	-	●	

Key  
 ● allowed matching; - not allowed matching

Analogic pressure-gauges standard materials

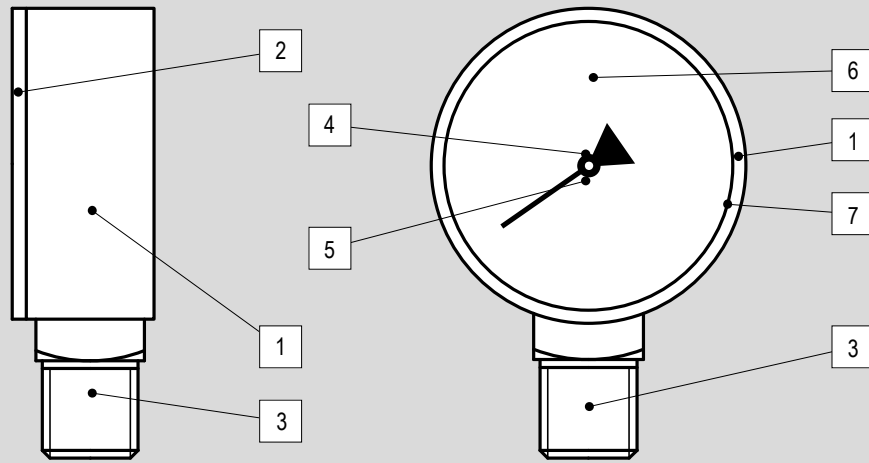

Position	Description	Material			
		M	MR	MF	MP
1	Housing	Black ABS		Chrome-plated or black painted steel	Chrome-plated steel
2	Screen	Kostil			
3	Connection	Brass OT58			
4	Elastic element	Tubular spring in copper alloy			
5	Movement	Brass			
6	Dial	White ABS with double scale (black = bar, red = psi)			
7	Welding	Sn-Pb alloy			

Notes

More versions available on request

3 - AIR TREATMENT

## Digital pressure-gauges and vacuum-gauges code key

Series	Function	Connection
<b>AKP60</b>	<b>P</b>	<b>14</b>
AKP60	P = pressure-gauges V = vacuum-gauges	18 = 1/8" 14 = 1/4"

### How to order

Series	Function	Connection
<b>AKP60</b>	<b>P</b>	<b>14</b>

### Notes

Options in the same grid are alternative to each others.

## Digital pressure switches code key

Series	Function	Circuit
<b>AKP43</b>	<b>P</b>	<b>030F3</b>
AKP43	P = Positive Pressures V = Vacuum C = Combined Pressures	010F3 = NPN 030F3 = PNP

### How to order

Series	Function	Circuit
<b>AKP43</b>	<b>P</b>	<b>030F3</b>

### Notes

Options in the same grid are alternative to each others.

Accessories for digital pressure-gauges, vacuum-gauges and pressure switches

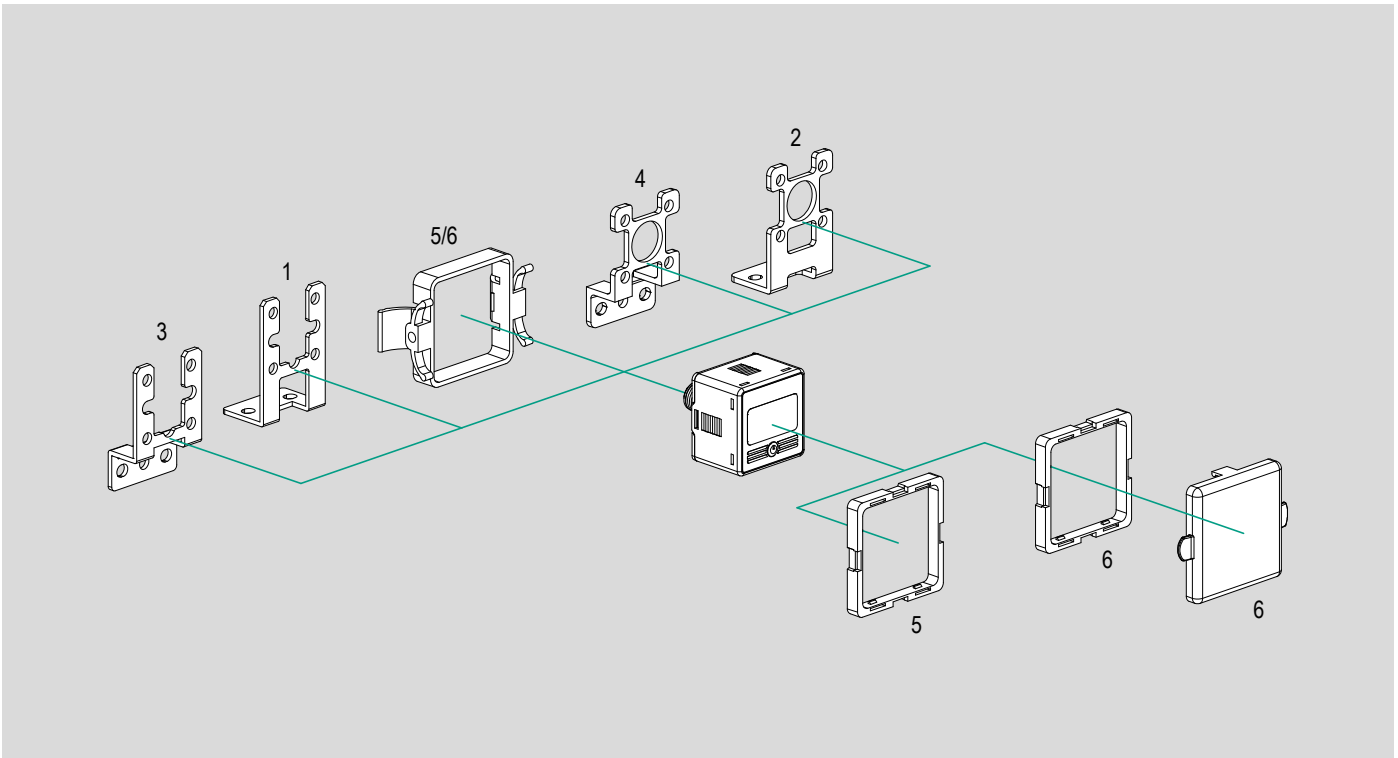

N.	Size	Item	Description	Matching			Code key page	Data sheet page
				M..	AKP60	AKP43		
1	1/8" ÷ 1/4"	ABT5	Straight mounting brackets	-	●	-	3.30.90	3.96.1
2	1/8"	AKP12	Straight mounting brackets	-	-	●		3.96.2
3	1/8" ÷ 1/4"	ABT6	Type "L" mounting brackets	-	●	-		3.96.1
4	1/8"	AKP13	Type "L" mounting brackets	-	-	●		3.96.2
5	1/8" ÷ 1/4"	APAC	Panel adapter	-	●	●		3.96.10
6	1/8" ÷ 1/4"	APAD	Panel adapter with front protective lid	-	●	●		3.96.10



Key  
 ● matching accessory; - not matching accessory

3 - AIR TREATMENT

# Pressure-gauges, vacuum-gauges and pressure switches

## Analogic pressure-gauges, 1/8" ÷ 1/4"

### Main features

Series	Description	Symbol
M.. 	Analogic pressure-gauges with rear connection	
MR..	Analogic pressure-gauges with in-line connection	
MF..	Analogic pressure-gauges with rear connection and flange	
MP..	Analogic pressure-gauges with rear connection and panel bracket	



### Technical data

Series	M	MR	MF	MP
Fluid	Compressed air			
Connections*	1/8"; 1/4"			
Dial dimensions*	Ø 40 mm; Ø 50 mm; Ø 63 mm			
Scale*	-1+0 bar; 0+2,5 bar; 0+4 bar; 0+6 bar; 0+10 bar; 0+12 bar		-1+0 bar; 0+6 bar; 0+12 bar	
Static pressure	Up to 3/4 of scale end			
Fluctuating pressure	Within 2/3 of scale end			
Maximum pressure (for short periods)	Up to the value of scale end			
Temperature range	-20°C ÷ +60°C			
Class protection	IP41			
Precision	Classe CI 1.6			
Threads	UNI-ISO 7/1 (BSPT)			

### Notes

\* For available combinations see page 3.30.3 and technical data of each series.  
More type, dial dimensions, connections and scale available on request.

# Pressure-gauges, vacuum-gauges and pressure switches

Analogic pressure-gauges with rear connection, 1/8" ÷ 1/4"



## Standard dimensions

Type: M

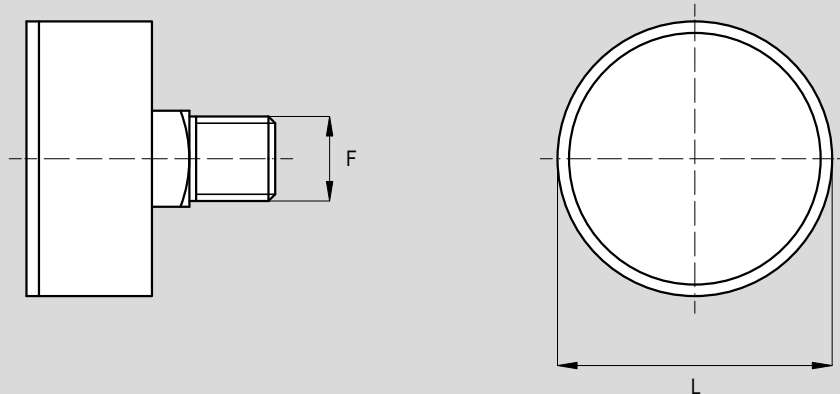

Item	Code	Connections	Dial Ø	Scale bar	F	L	Weight g
M40A-1÷0	028501	1/8"	Ø40	-1÷0	1/8"	40	38
M40A0÷2,5	028651			0÷2,5	1/8"	40	38
M40A0÷4	028701			0÷4	1/8"	40	38
M40A0÷6	028801			0÷6	1/8"	40	38
M40A0÷10	028851			0÷10	1/8"	40	38
M40A0÷12	028901			0÷12	1/8"	40	38
M50A-1÷0	028502	1/8"	Ø50	-1÷0	1/8"	50	40
M50A0÷2,5	028900			0÷2,5	1/8"	50	40
M50A0÷4	028702			0÷4	1/8"	50	40
M50A0÷6	028802			0÷6	1/8"	50	40
M50A0÷10	028915			0÷10	1/8"	50	40
M50A0÷12	028902			0÷12	1/8"	50	40
M50B-1÷0	028925	1/4"	Ø50	-1÷0	1/4"	50	40
M50B0÷2,5	028994			0÷2,5	1/4"	50	40
M50B0÷4	028917			0÷4	1/4"	50	40
M50B0÷6	028992			0÷6	1/4"	50	40
M50B0÷10	028993			0÷10	1/4"	50	40
M50B0÷12	028913			0÷12	1/4"	50	40
M63B-1÷0	028503	1/4"	Ø63	-1÷0	1/4"	63	75
M63B0÷2,5	028995			0÷2,5	1/4"	63	75
M63B0÷4	028703			0÷4	1/4"	63	75
M63B0÷6	028803			0÷6	1/4"	63	75
M63B0÷10	028996			0÷10	1/4"	63	75
M63B0÷12	028903			0÷12	1/4"	63	75

## Notes

More versions available on request



Standard dimensions

Type: **MR**

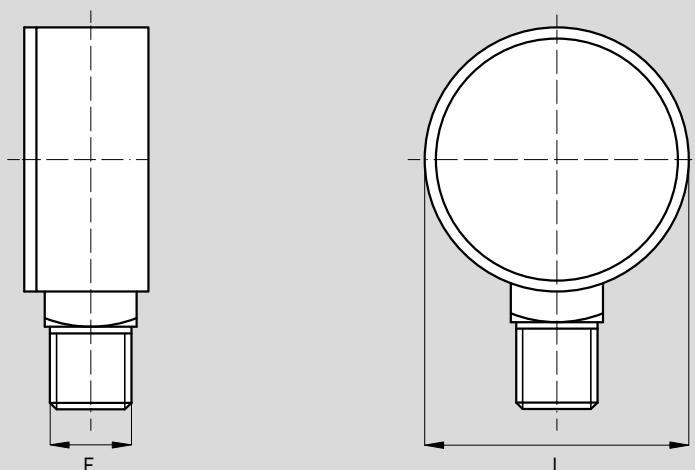

Item	Code	Connections	Dial Ø	Scale bar	F	L	Weight g
MR40A-1+0	028504	1/8"	Ø40	-1+0	1/8"	40	38
MR40A0+6	028804			0+6	1/8"	40	38
MR40A0+12	028904			0+12	1/8"	40	38
MR50B-1+0	029000	1/4"	Ø50	-1+0	1/4"	50	40
MR50B0+6	028977			0+6	1/4"	50	40
MR50B0+12	028905			0+12	1/4"	50	40
MR63B-1+0	028506	1/4"	Ø63	-1+0	1/4"	63	75
MR63B0+6	028806			0+6	1/4"	63	75
MR63B0+12	028906			0+12	1/4"	63	75

Notes

More versions available on request

Standard dimensions

Type: MF

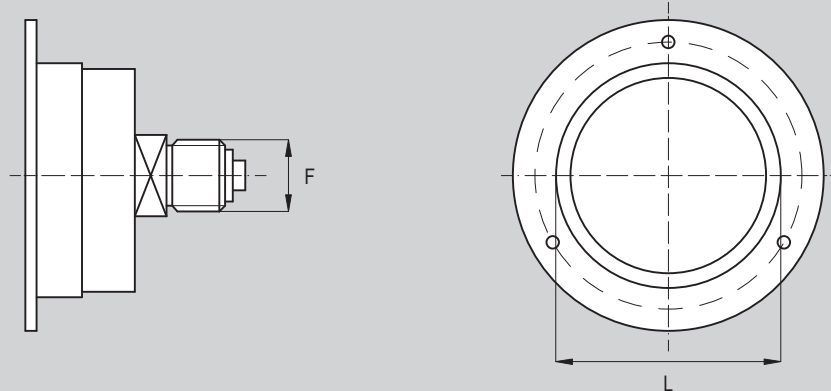

Item	Code	Connections	Dial Ø	Scale (bar)	F	L	Weight g
MF40A-1÷0	028510	1/8"	Ø40	-1÷0	1/8"	43	74
MF40A0÷6	028810			0÷6	1/8"	43	74
MF40A0÷12	028910			0÷12	1/8"	43	74
MF50A-1÷0	029013	1/8"	Ø50	-1÷0	1/8"	53	102
MF50A0÷6	028811			0÷6	1/8"	53	102
MF50A0÷12	029072			0÷12	1/8"	53	102
MF50B-1÷0	028511	1/4"	Ø50	-1÷0	1/4"	53	102
MF50B0÷6	028714			0÷6	1/4"	53	102
MF50B0÷12	028911			0÷12	1/4"	53	102
MF63B-1÷0	028512	1/4"	Ø63	-1÷0	1/4"	63,5	145
MF63B0÷6	028812			0÷6	1/4"	63,5	145
MF63B0÷12	028912			0÷12	1/4"	63,5	145

Notes

More versions available on request

Standard dimensions

Type: **MP**

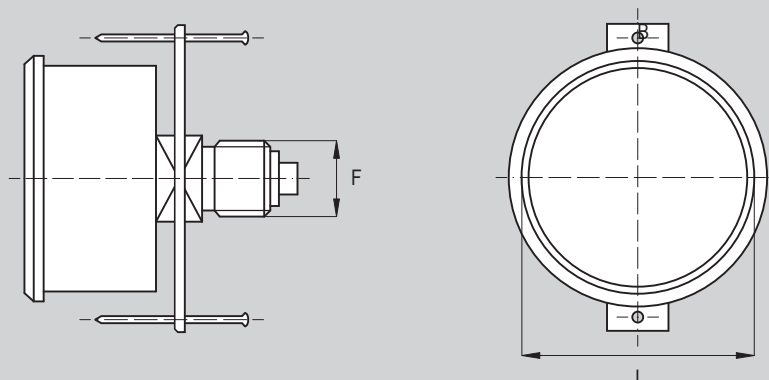

Item	Code	Connections	Dial Ø	Scale (bar)	F	L	Weight g
MP40A-1÷0	028507	1/8"	Ø40	-1÷0	1/8"	39	99
MP40A0÷6	028807			0÷6	1/8"	39	99
MP40A0÷12	028907			0÷12	1/8"	39	99
MP50B-1÷0	028508	1/4"	Ø50	-1÷0	1/4"	52	145
MP50B0÷6	028808			0÷6	1/4"	52	145
MP50B0÷12	028908			0÷12	1/4"	52	145
MP63B-1÷0	028509	1/4"	Ø63	-1÷0	1/4"	62	174
MP63B0÷6	028809			0÷6	1/4"	62	174
MP63B0÷12	028909			0÷12	1/4"	62	174

Notes

More versions available on request

# Pressure-gauges, vacuum-gauges and pressure switches

## Digital pressure-gauges and vacuum-gauges, 1/8" ÷ 1/4"



### Main features

Series	Description	Symbol
AKP60P..	Digital pressure-gauges	
AKP60V..	Digital vacuum-gauges	



### Technical data

Series	AKP60P		AKP60V	
	Fluid	Compressed filtered air, incombustible and non-corrosive gases		
Function	Pressure-gauge		Vacuum-gauge	
Rated pressure range <sup>(1)</sup>	0 ÷ 10 bar		-1,01 ÷ 0 bar	
Display pressure range <sup>(2)</sup>	0,1 ÷ 10 bar		-1,01 ÷ + 0,1 bar	
Maximum pressure	15 bar		3 bar	
Pressure units	MPa, kgf/cm <sup>2</sup> , bar, psi (user selectable)		kPa, bar, psi, mmHg (user selectable)	
Pressure resolution	- 0.001 MPa 0.01 kgf/cm <sup>2</sup> 0.01 bar 0.1 psi -		1 kPa - 0.01 bar 0.1 psi 1 mmHg	
Repeatability	≤ ±0.2% F.S. ±1 digit		≤ ±1% F.S. ±1 digit	
LCD display	3½ digit, 7 segment			
Class protection	IP65			
Temperature range	0°C ÷ +50°C			
Lithium battery	CR 2032 (battery life 1 year, 5 times/day) low battery indicator on display			
Display turn off	60 sec.			
Connections	1/8"-M5	1/4"-M5	1/8"-M5	1/4"-M5

### Notes

- (1) Pressure range within technical features of components are granted.
- (2) Pressure range possible to display on component. Pressure values displayed can also be off the nominal pressure range and in this case technical features are not granted.

Function	
AKP60P	AKP60V

Panel mounting\*

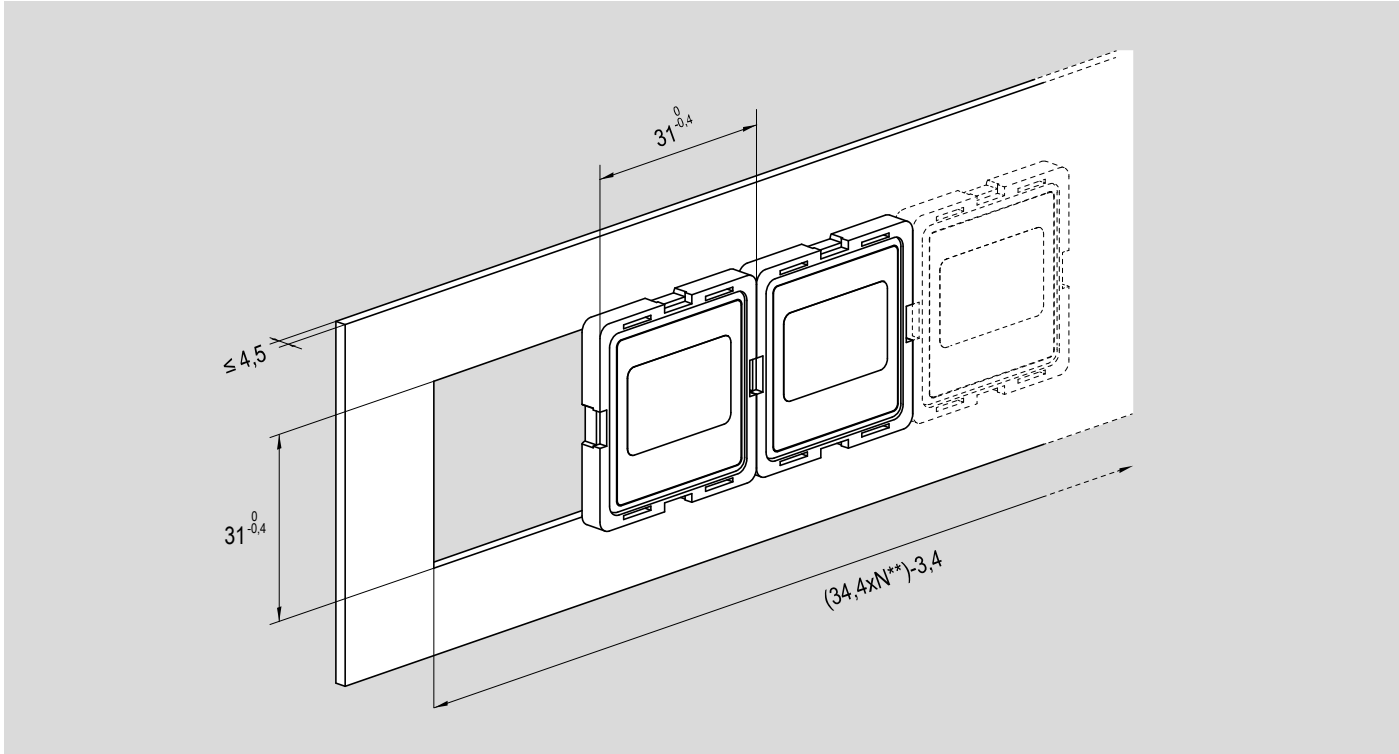

\*Possible only with APAD or APAC , see page 3.30.90  
 \*\*N = number of components to install

Standard dimensions

Type: **AKP60**

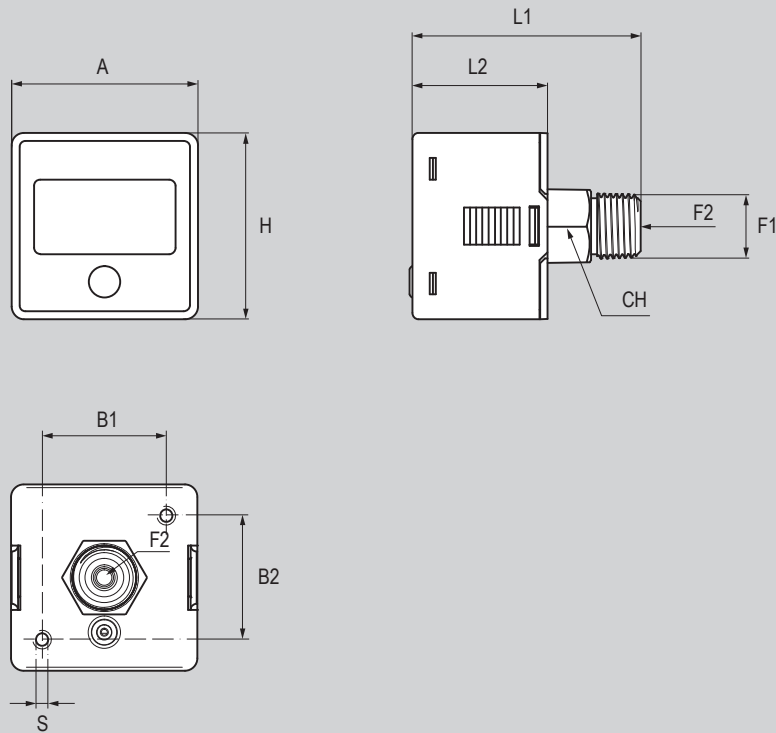

Item	Code	Connections	Function	A	B1	B2	CH	F1	F2	H	L1	L2	S	Weight g
AKP60P18	024805	1/8"-M5	Pressure-gauge	30	20	20	12	G1/8"	M5	30	37	21,8	M3	40
AKP60P14	024806	1/4"-M5		30	20	20	14	G1/4"	M5	30	37	21,8	M3	40
AKP60V18	024803	1/8"-M5	Vacuum-gauge	30	20	20	12	G1/8"	M5	30	37	21,8	M3	40
AKP60V14	024804	1/4"-M5		30	20	20	14	G1/4"	M5	30	37	21,8	M3	40

3 - AIR TREATMENT

# Pressure-gauges, vacuum-gauges and pressure switches

## Digital pressure switches, 1/8"



### Main features

Series	Description	Symbol
AKP43P..	Positive pressures digital switch	
AKP43V..	Vacuum digital switch	
AKP43C..	Combined pressures digital switch	



### Technical data

Series	AKP43P	AKP43V	AKP43C
Fluid	Compressed filtered air, incombustible and non-corrosive gases		
Function	Positive pressures digital switch	Vacuum digital switch	Combined pressures digital switch
Rated pressure range <sup>(1)</sup>	0 ÷ 10 bar	-1,01 ÷ 0 bar	-1 ÷ 1 bar
Display pressure range <sup>(2)</sup>	0,1 ÷ 10 bar	-1,01 ÷ + 0,1 bar	-1,01 ÷ + 1,01 bar
Maximum pressure	15 bar	3 bar	
Pressure units	MPa, kgf/cm2, bar, psi	kPa, kgf/cm2, bar, psi, inHg, mmHg	
Pressure resolution	- 0.001 MPa 0.01 kgf/cm2 0.01 bar 0.1 psi -	1 kPa - 0.001 kgf/cm2 0.001 bar 0.01 psi 0.01 inHg 1 mmHg	
Repeatability	≤ ±0.2% F.S. ±1 digit		
LCD display	Red / Green main&unit display - Orange sub-display (7 segment)		
Protection class	IP40		
Temperature range	0 ÷ +50°C		
Ambient humidity range	35 ÷ 85 %RH (without condense)		
Voltage	12 ÷ 24 V DC (±10%)		
Current consumption	≤ 40 mA (without load)		
Switch output (protected from over-run)	Open collector NPN (two outlets)	Open collector PNP (two outlets)	
	Max. load current: 125 mA	Max. load current: 125 mA	
	Max. supply voltage: 30V DC	Max. supply voltage: 24V DC	
	Residual voltage: ≤ 1.5V	Residual voltage: ≤ 1.5V	
	Response time: ≤ 2,5 ms (chattering-proof function 25, 100, 250, 500, 1000, 1500 ms)		
Hysteresis <sup>(3)</sup>	Adjustable		
Analog output	Output current: 1 ÷ 5V ± 2,5% F.S.		
	Linearity ± 1% F.S.		
	Output impedance ≈ 1kΩ		
Connections	1/8" - M5		
Main cable (included)	Oil resistant cable (0,15mm2) - Lenght 200 mm		

### Notes

- (1) Pressure range within technical features of components are granted.  
 (2) Pressure range possible to display on component. Pressure values displayed can also be off the nominal pressure range and in this case technical features are not granted.  
 (3) Hysteresis value adjustable from 1 to 8 digits.

Electric scheme

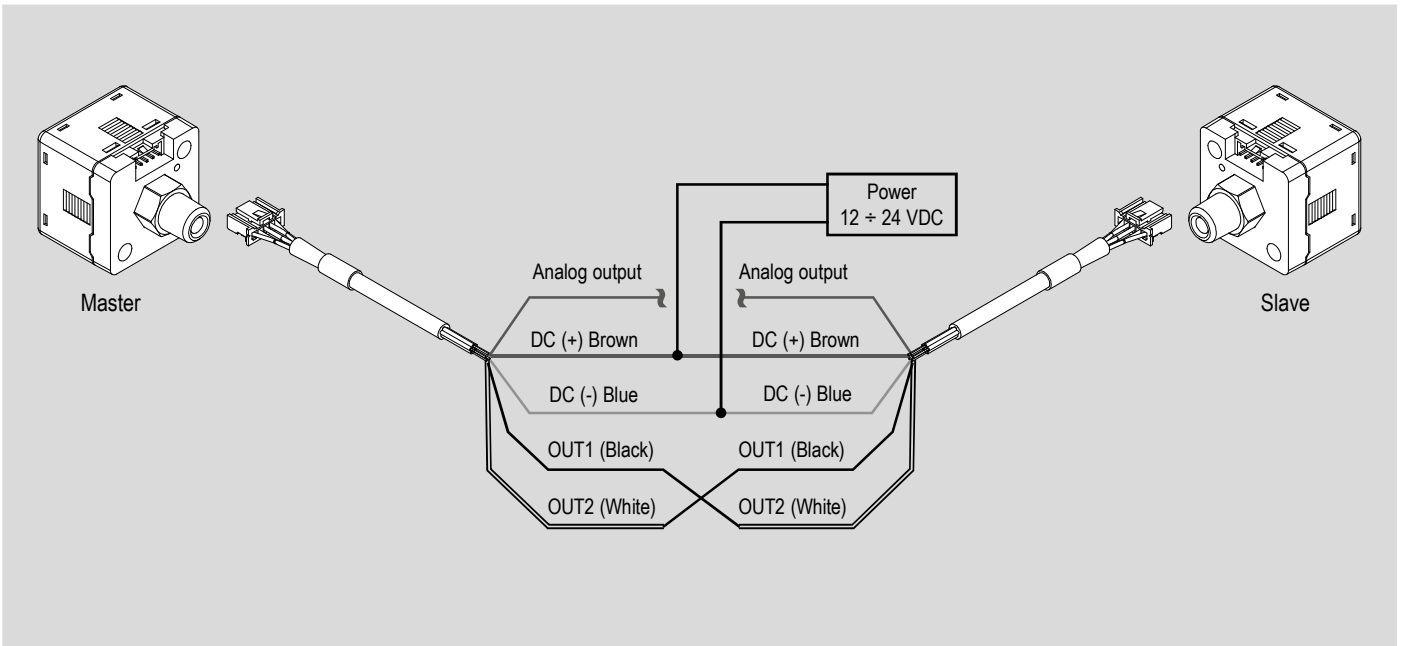

Circuit diagram

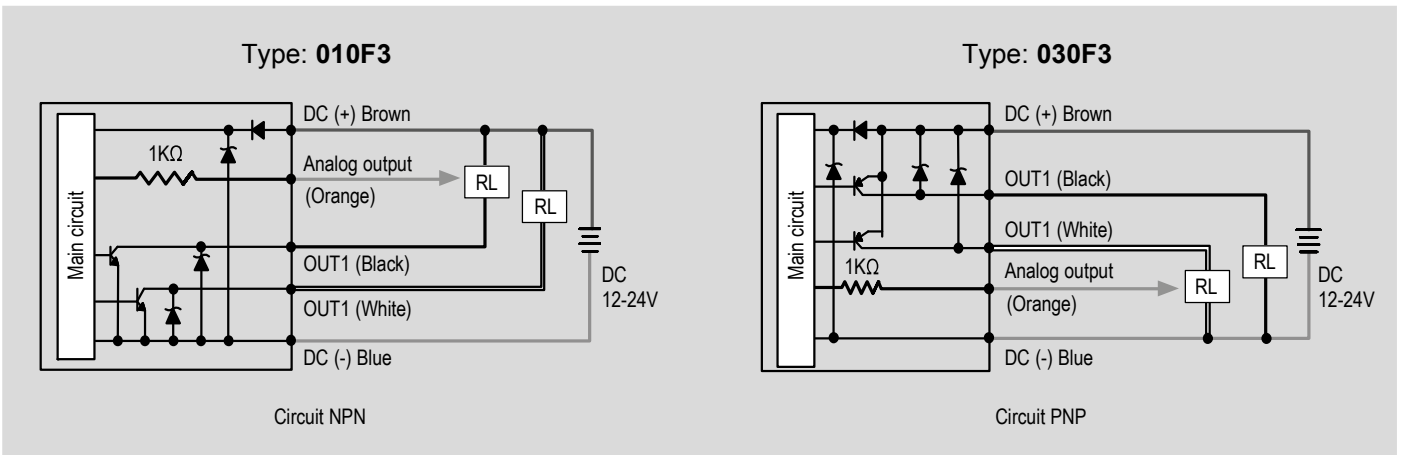

Analog output

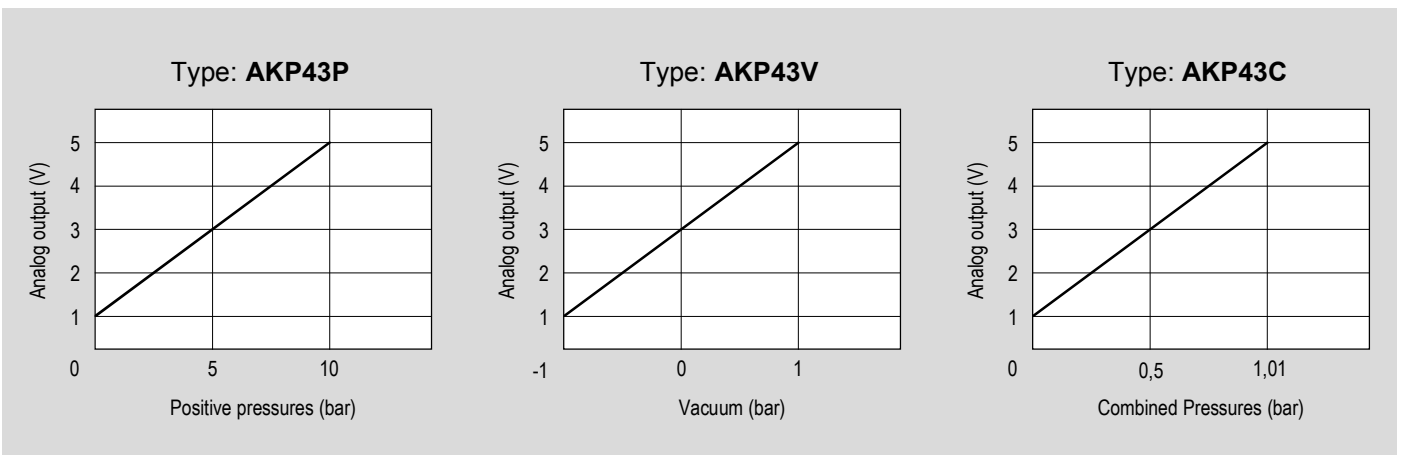



Function

AKP43..

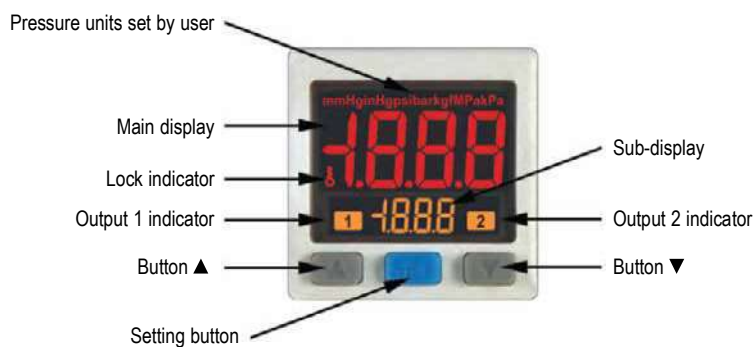

Panel mounting\*

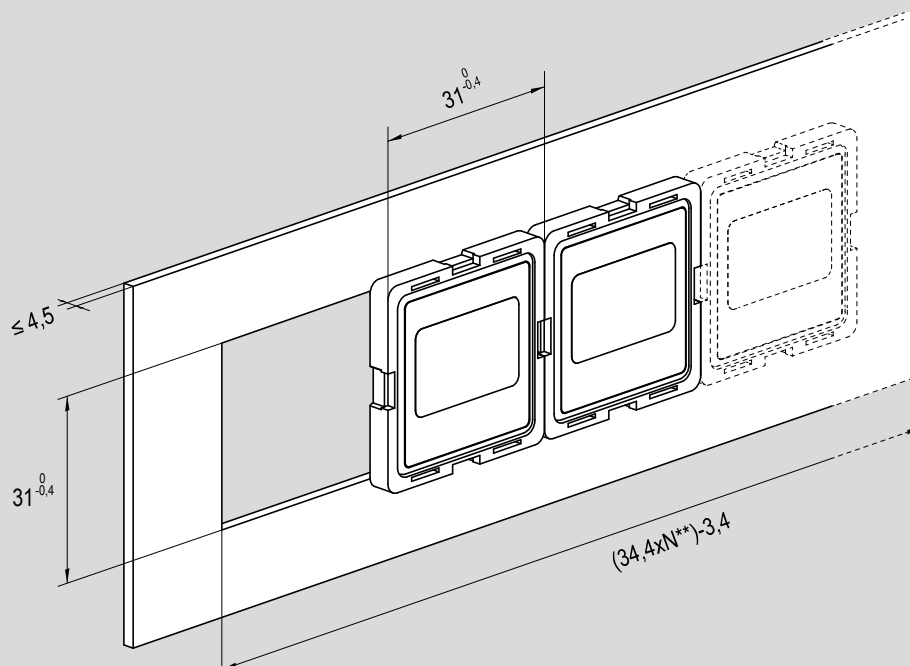

\*Possible only with APAD or APAC , see page 3.30.90

\*\*N = number of components to install

Standard dimensions

Type: **AKP43**

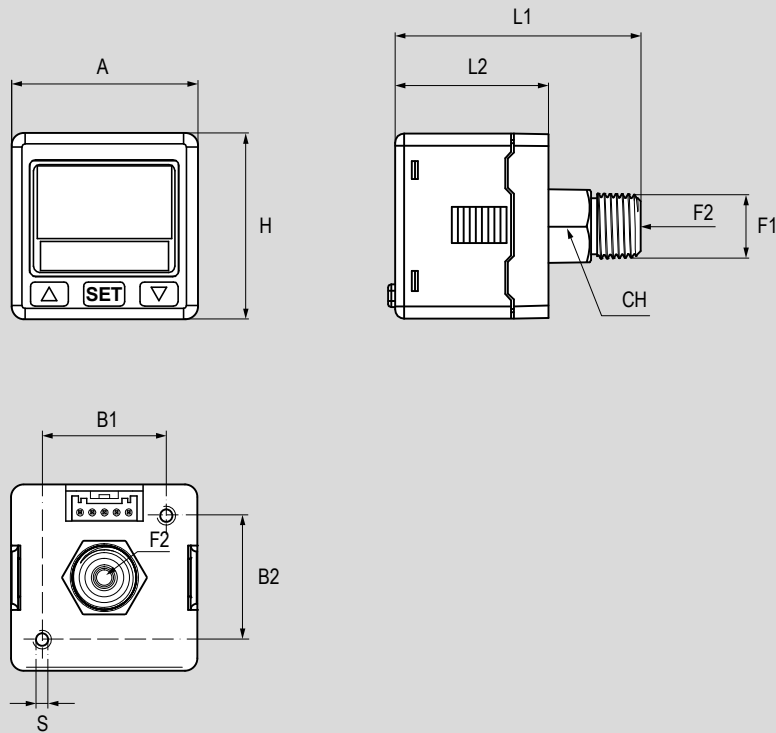

Item	Code	Connections	Function	Circuit	A	B1	B2	CH	F1	F2	H	L1	L2	S	Weight g
AKP43P010F	024810	1/8"-M5	Positive pressures digital switch	NPN	30	20	20	12	G1/8"	M5	30	40,3	25,2	M3	80
AKP43P030F	024811	1/8"-M5		PNP	30	20	20	12	G1/8"	M5	30	40,3	25,2	M3	80
AKP43V010F	024812	1/8"-M5	Vacuum digital switch	NPN	30	20	20	12	G1/8"	M5	30	40,3	25,2	M3	80
AKP43V030F	024813	1/8"-M5		PNP	30	20	20	12	G1/8"	M5	30	40,3	25,2	M3	80
AKP43C010F	024814	1/8"-M5	Combined pressures digital switch	NPN	30	20	20	12	G1/8"	M5	30	40,3	25,2	M3	80
AKP43C030F	024815	1/8"-M5		PNP	30	20	20	14	G1/8"	M5	30	40,3	25,2	M3	80

3 - AIR TREATMENT

Straight mounting brackets

	Size	Code	Item	Matching
	1/8" - 1/4"	024807	ABT5	AKP60..
	1/8"	024816	AKP12	AKP43..

Type "L" mounting brackets

	Size	Code	Item	Matching
	1/8" - 1/4"	024808	ABT6	AKP60..
	1/8"	024817	AKP13	AKP43..

Panel adapter

	Size	Code	Item	Matching
	1/8" - 1/4"	024809	APAC	AKP60.. AKP43..

Panel adapter with front protective liv

	Size	Code	Item	Matching
	1/8" - 1/4"	024802	APAD	AKP60.. AKP43..



# END-OF-LINE

components



Find out our  
key products



**Solution for most applications**



**Easy and intuitive choice**



**Excellent value for money**



**Wide availability**



**Fast delivery**



## Main features and certifications

End-of-line components. Accessories with different functions to meet a variety of needs in an industrial plant. Supplied as standard in compliance to Reach and RoHS directives.



## Automatic condense drains series A..FLSA, 1/4" ÷ 1/2"

from page 3.40.10



Automatic condense drains, available in size 1/4", 3/8" and 1/2". For installation at the end of the line to grant the drain of the condense accumulating in the system. With metal cup protection and air interception as standard, and with automatic or manual exhaust option.



## Silenced exhaust filters series A..FLFS, 1/4" ÷ 1/2"

from page 3.40.30



Silenced exhaust filters, available in size 1/4", 3/8" and 1/2". For installation at the end of the line to reduce the noise of the system exhaust, recover residual oil and water, and keep the whole system clean. Supplied complete of mounting bracket



Code key

Series	Size	Type
<b>A</b>	<b>12</b>	<b>FLSA</b>
A	14 = 1/4"	FLSA = Automatic condense drains
	38 = 3/8"	FLFS = Silenced exhaust filters
	12 = 1/2"	

How to order

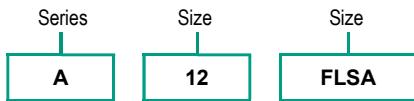

Notes

For standard materials see table below.  
Options in the same grid are alternative to each others.

Standard materials

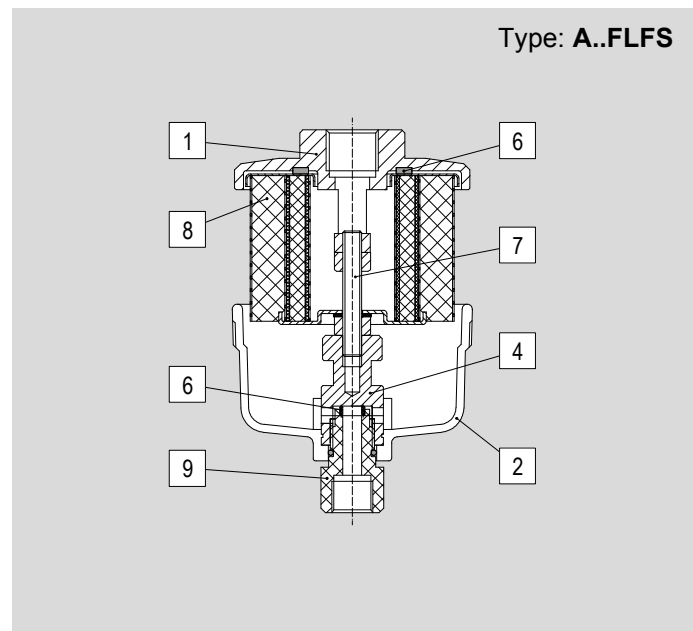
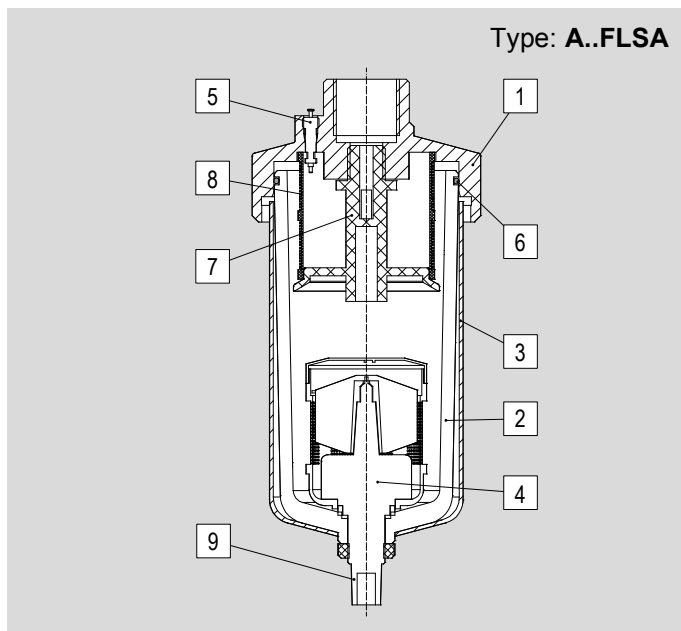

Position	Description	Material	
		A..FLSA	A..FLFS
1	Body	Aluminium	
2	Cup	Polycarbonate	
3	Cup protection	Aluminium	-
4	Drain system	Acetalic resin - NBR	Aluminium alloy (LY12)
5	Air release valve	Acetalic resin - NBR	-
6	Seals	NBR	
7	Support screw	POM	Stainless Steel
8	Filtering element	POM	Noise-absorbing fiber with metal protection
9	Drain valve	POM	Nylon (PA6)

Accessories

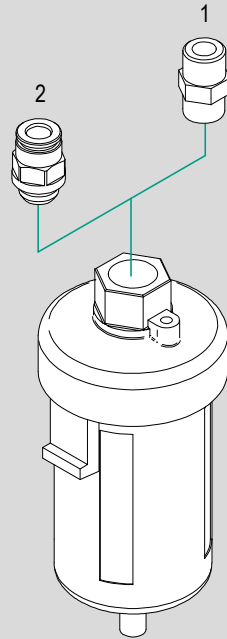

N.	Size	Item	Description	Matching		Code key and data sheet page
				A..FLSA	A..FLFS	
1	1/4" ÷ 1/2"	A..	BSP nipple male/male	●	●	4.35.1
2	1/4" ÷ 1/2"	R..	Push-in fittings	●	●	4.2.1

Key  
 ● matching accessory; - not matching accessory

3 - AIR TREATMENT



# End-of-line components

## Series FLSA, 1/4" ÷ 1/2"



### Main features

Code	Item	Size	Function	Symbol
090295	A14FLSA	1/4"	Automatic condense drain	
090296	A38FLSA	3/8"		
090257	A12FLSA	1/2"		



### Technical data

Type	A14FLSA	A38FLSA	A12FLSA
Size	1/4"	3/8"	1/2"
Fluid	Compressed air		
Maximum inlet pressure	15 bar		
Pressione d'esercizio	1,5 ÷ 10 bar		
Temperature range	+5°C ÷ +60°C		
Drain type	Normally open		
Drain operation	Automatic		
Mounting	Vertical		

### Operation notes

When any pressure is applied, the float drops and the valve closes the chamber bore. The piston is pushed down by the spring and drainage passes through the elongated chamber bore to enter the housing and be discharged.

When a pressure greater than 1.5 bar is applied in the chamber, it overcomes the spring force, allowing the piston to rise and, adhering to the o-ring, insulates the inside of the chamber from the outside.

When the condense is accumulated the float rises and opens the chamber bore, allowing drainage through its guide.

Standard dimensions

Type: A..FLSA

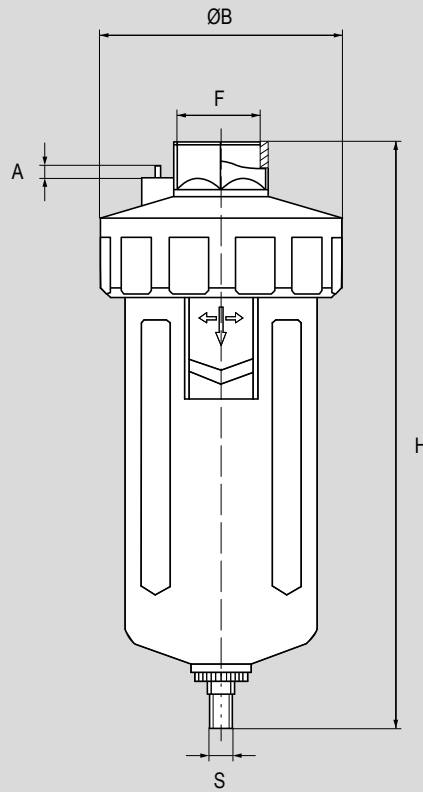

3 - AIR TREATMENT

Item	Code	Size	A	ØB	H	F	S	Weight g
A14FLSA	090295	1/4"	2,5	72	175	G1/4"	R1/8"	-
A38FLSA	090296	3/8"	2,5	72	175	G3/8"	R1/8"	-
A12FLSA	090257	1/2"	2,5	72	175	G1/2"	R1/8"	-

# End-of-line components

## Series FLFS, 1/4" ÷ 1/2"



### Main features

Code	Item	Size	Function	Symbol
090297	A14FLFS	1/4"	Silenced exhaust filters	
090298	A38FLFS	3/8"		
090299	A12FLFS	1/2"		



### Technical data

Type	A14FLFS	A38FLFS	A12FLFS
Size	1/4"	3/8"	1/2"
Fluid	Compressed air		
Pressure range	1,5 ÷ 10 bar		
Temperature range	+5°C ÷ +60°C		
Maximum flow rate	200 l/min.	300 l/min.	1000 l/min.
Section	12 mm <sup>2</sup>	16 mm <sup>2</sup>	55 mm <sup>2</sup>
Drain operation	Automatic		
Noise reduce level	35 db		
Oil recovery	99,9%		
Mounting	Vertical		

### Operation notes

The component must be installed in vertical position.  
 The component must not come into contact with, or otherwise be exposed to, aggressive substances or solvents.  
 For spare parts, please contact the sales department.

Standard dimensions

Type: A..FLFS

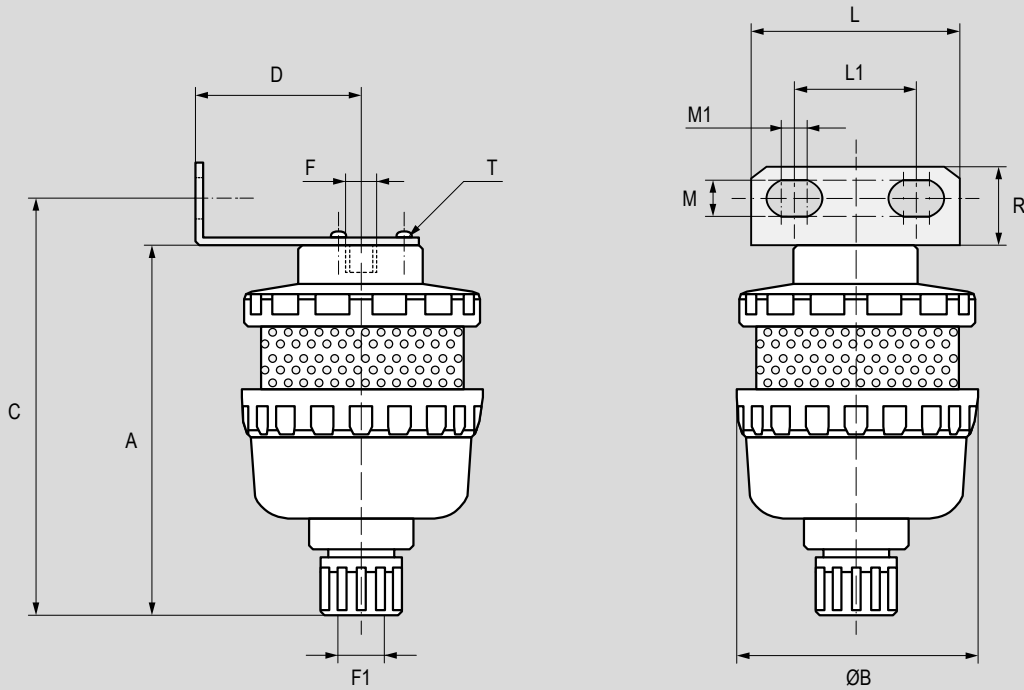

Item	Code	Size	A	ØB	C	D	F	F1	L	L1	M	M1	R	T	Weight g
A14FLFS	090297	1/4"	88	57,5	100	40	G1/4"	G1/4"	50	30	7	5	20	M3x8	120
A38FLFS	090298	3/8"	120,5	76,5	140,5	55	G3/8"	G1/4"	50	30	7	5	30	M3x8	250
A12FLFS	090299	1/2"	173,5	102,5	193,5	70	G1/2"	G1/4"	70	40	7	5	30	M3x8	550

Notes

Mounting bracket included.

# MOUNTING

accessories



Find out our  
key products



**Solution for most applications**



**Easy and intuitive choice**



**Excellent value for money**



**Wide availability**



**Fast delivery**



## Main features and certifications

Mounting accessories for modular components, for microregulators and for digital pressure-gauges, vacuum-gauges and pressure switches. Available in different types and sizes. Supplied as standard in compliance to Reach and RoHS directives.



### Spacers series D, 1/4" ÷ 1"

from page 3.92.1



Spacers for modular components, available in sizes from 1/4" to 1". Equipped with O-ring, allow the mounting of two modular components through the "in"/"out" port. Compatible with all modular components.

### Spacers with "T" type porting block series DT, 1/4" ÷ 1"

from page 3.92.1



Spacers with "T" type porting block for modular components, available in sizes from 1/4" to 1". Equipped with O-ring, allow the mounting of two modular components through the "in"/"out" port. Thanks to the threaded "T" connection on the component, it is possible to obtain an air flow detour or apply pressure switches. It can be used for connection between filters type A..F and regulators type A..R, mounted with knob facing the opposite side from the "T" type port.

### Spacers with "L" type bracket series DSL, 1/4" ÷ 1"

from page 3.92.2



Spacers with "L" type bracket for modular components, available in sizes from 1/4" to 1". Equipped with O-ring, allow the mounting of two modular components through the "in"/"out" port, and allow also the fastening of the assembly, thanks to the "L" bracket. Spare brackets to be ordered separately.

### Spacers with "T" type bracket series DST, 1/4" ÷ 1"

from page 3.92.3



Spacers with "T" type bracket for modular components, available in sizes from 1/4" to 1". Equipped with O-ring, allow the mounting of two modular components through the "in"/"out" port, and allow also the fastening of the assembly, thanks to the "T" bracket. Spare brackets to be ordered separately.

### Brackets series SR, 1/4" ÷ 1"

from page 3.94.1



Mounting brackets for regulators, filter-regulators and microregulators, available in sizes from 1/4" to 1". Allow the single component panel mounting.

### Brackets series SRP, 1/8" ÷ 1/2"

from page 3.94.2



Mounting brackets for precision regulators available in sizes from 1/8" to 1/2". Allow the single component panel mounting.

### Brackets series SFL, 1/4" ÷ 1"

from page 3.94.2



Mounting brackets for filters, mist separators and lubricators, available in sizes from 1/4" to 1". Allow the single component panel mounting.

## Mounting brackets series ABT and AKP, 1/8" ÷ 1/4"

from page 3.96.1



Mounting brackets for digital pressure-gauges, vacuum-gauges and pressure switches. Compatible with size 1/8" and 1/4". Available in versions straight and type "L". Allow the component panel mounting.

## Panel adapters series APAC and APAD, 1/8" ÷ 1/4"

from page 3.96.10



Panel adapters for digital pressure-gauges, vacuum-gauges and pressure switches. Compatible with 1/8" and 1/4". Available in version with or without front protective lip. Allow the component panel mounting.

## Brackets matching

Series	Description	Matching								
		A..F (1/4" - 1")	A..FD (1/4" - 1")	A..R (1/4" - 1")	A..RP (1/8" - 1/2")	A..L (1/4" - 1")	A..LG (1/4" - 1")	A..FRR (1/4" - 1")	A..FRRL (1/4" - 1")	VMS.. (1/4" - 1")
D..	Spacers	●	●	●	●	●	●	●	●	●
DT..	Spacers with "T" type porting block	● <sup>(1)</sup>	-	● <sup>(1)</sup>	-	-	-	-	-	-
DSL..	Spacers with "L" type bracket	●	●	●	●	●	●	●	●	●
DST..	Spacers with "T" type bracket	●	●	●	●	●	●	●	●	●
SR..	Brackets for regulators, filter-regulators and microregulators	-	-	●	-	-	-	●	●	-
SRP..	Brackets for precision regulators	-	-	-	●	-	-	-	-	-
SFL..	Brackets for filters, mist separators and lubricators	●	●	-	-	●	-	-	-	-
ABT5	Straight brackets for digital pressure-gauges and vacuum-gauges	-	-	-	-	-	-	-	-	-
ABT6	Type "L" brackets for digital pressure-gauges and vacuum-gauges	-	-	-	-	-	-	-	-	-
AKP12	Straight brackets for digital pressure switches	-	-	-	-	-	-	-	-	-
AKP13	Type "L" brackets for digital pressure switches	-	-	-	-	-	-	-	-	-
APAC	Panel adapters for digital pressure-gauges, vacuum-gauges and pressure switches	-	-	-	-	-	-	-	-	-
APAD	Panel adapters with front protective liv for digital pressure-gauges, vacuum-gauges and pressure switches	-	-	-	-	-	-	-	-	-

### Key

● allowed matching; - not allowed matching

(1) Between filter and regulator only, the regulator with knob facing the opposite side from the "T" type port.



Matching														See page
AVP..E (1/4" - 1/2")	AVP..P (1/4" - 1/2")	A..F (1 1/2" - 2")	A..R (1 1/2" - 2")	A..L (1 1/2" - 2")	AC700 (1/8" - 1/4")	M	MR	MF	MP	AKP60	AKP43	A..FLSA	A..FLFS	
●	●	-	-	-	-	-	-	-	-	-	-	-	-	3.92.1
-	-	-	-	-	-	-	-	-	-	-	-	-	-	3.92.1
●	●	-	-	-	-	-	-	-	-	-	-	-	-	3.92.2
●	●	-	-	-	-	-	-	-	-	-	-	-	-	3.92.3
-	-	-	-	-	●	-	-	-	-	-	-	-	-	3.94.1
-	-	-	-	-	-	-	-	-	-	-	-	-	-	3.94.2
-	-	-	-	-	-	-	-	-	-	-	-	-	-	3.94.2
-	-	-	-	-	-	-	-	-	-	●	-	-	-	3.96.1
-	-	-	-	-	-	-	-	-	-	●	-	-	-	3.96.1
-	-	-	-	-	-	-	-	-	-	-	●	-	-	3.96.2
-	-	-	-	-	-	-	-	-	-	-	●	-	-	3.96.2
-	-	-	-	-	-	-	-	-	-	●	●	-	-	3.96.10
-	-	-	-	-	-	-	-	-	-	●	●	-	-	3.96.10



# Mounting accessories

## Mounting accessories for modular components



### Main features

**1/4" ÷ 1"**     **D..**  
 Sizes            Type

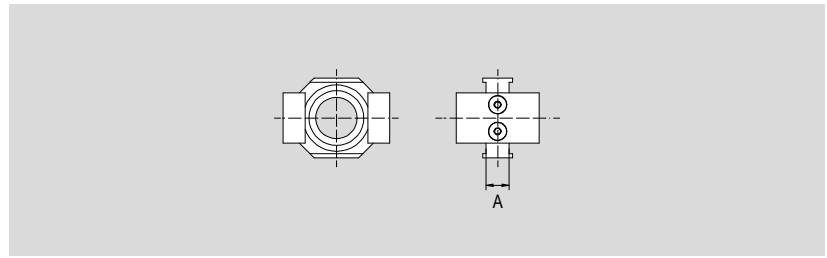

### Technical data

Type	Description	Material	Seal
D..	Spacer for modular components, with O-ring. Compatible with all modular components.	Painted aluminium	NBR

### Dimensions

Size	Code	Item	A	Weight (g)
1/4"	090148	D14	10	-
3/8"	090149	D38	11	-
1/2"	090150	D12	14	-
1"	090151	D01	15	-

### Main features

**1/4" ÷ 1"**     **DT..**  
 Sizes            Type

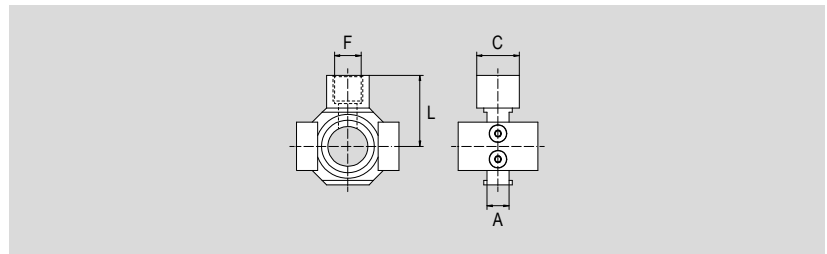

### Technical data

Type	Description	Material	Seal
DT..	Spacer with "T" type porting block for modular components, with O-ring. The "T" connection allows the airflow detour or to apply pressure switches. For mounting on the lubricator type A..L, the spacer is to be applied on the "out" port only. Not compatible with filter-regulators type A..FRR.	Painted aluminium	NBR

### Dimensions

Size	Code	Item	A	C	F	L	Weight (g)
1/4"	090129	DT14	10	19	G1/4"	29	-
3/8"	090130	DT38	11	19	G1/4"	33	-
1/2"	090131	DT12	14	24	G3/8"	39	-
1"	090132	DT01	15	30	G1/2"	50,5	-

# Mounting accessories

## Mounting accessories for modular components



### Main features

**1/4" ÷ 1"** **DSL..**  
 Sizes Type

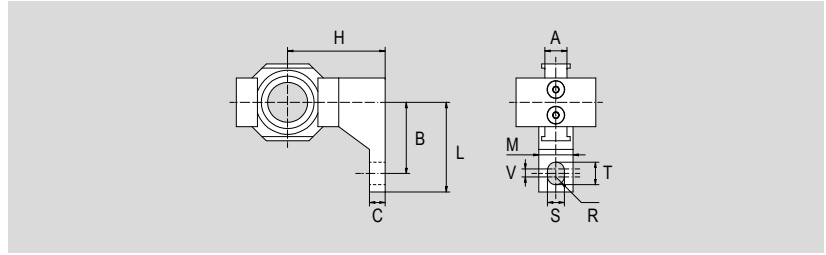

### Technical data

Type	Description	Material	Seal
DSL..	Spacer with "L" type bracket for modular components, with O-ring. Compatible with all modular components.	Painted aluminium	NBR

### Dimensions

Size	Code	Item	A	B	C	H	L	M	R	S	T	V	Weight (g)
1/4"	090133	DSL14	10	24	5	30	33	15	2,75	5,5	8,5	3	-
3/8"	090134	DSL38	11	35	7	41	45	16	3,5	7	11	4	-
1/2"	090135	DSL12	14	40	7	50	50	22	4,5	9	13	4	-
1"	090136	DSL01	15	50	10,5	69,8	63	23	6	12	16	4	-

### Main features

**1/4" ÷ 1"** **SL..**  
 Sizes Type

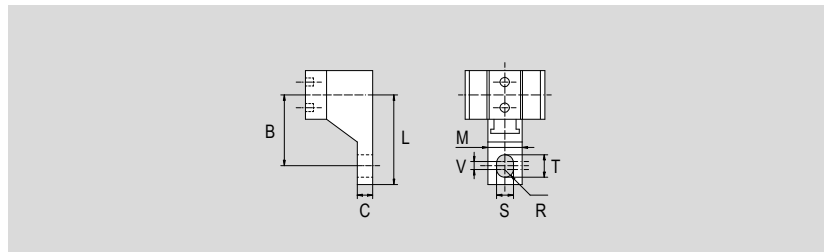

### Technical data

Type	Description	Material
SL..	"L" type bracket. Spare part for spacer with "L" type bracket type DSL..	Painted aluminium

### Dimensions

Size	Code	Item	B	C	L	M	R	S	T	V	Weight (g)
1/4"	090163	SL14	24	5	33	15	2,75	5,5	8,5	3	-
3/8"	090164	SL38	35	7	45	16	3,5	7	11	4	-
1/2"	090165	SL12	40	7	50	22	4,5	9	13	4	-
1"	090166	SL01	50	10,5	63	23	6	12	16	4	-

3 - AIR TREATMENT

# Mounting accessories

Mounting accessories for modular components



## Main features

**1/4" ÷ 1"**     **DST..**

Sizes                     Type

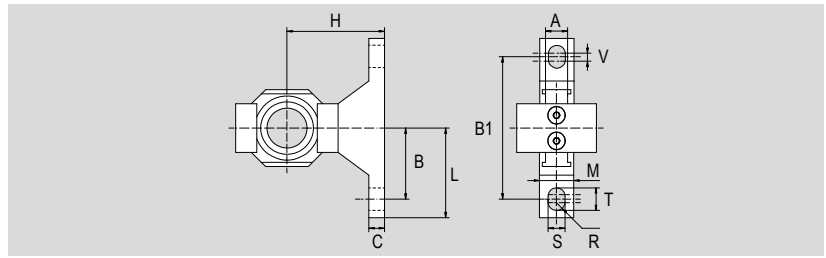

## Technical data

Type	Description	Material	Seal
DST..	Spacer with "T" type bracket for modular components, with O-ring. Compatible with all modular components.	Painted aluminium	NBR

## Dimensions

Size	Code	Item	A	B	B1	C	H	L	M	R	S	T	V	Weight (g)
1/4"	090137	DST14	10	24	48	5	30	33	15	2,75	5,5	8,5	3	-
3/8"	090138	DST38	11	35	70	7	41	45	16	3,5	7	11	4	-
1/2"	090139	DST12	14	40	80	7	50	50	22	4,5	9	13	4	-
1"	090140	DST01	15	50	100	10,5	69,8	63	23	6	12	16	4	-

## Main features

**1/4" ÷ 1"**     **ST..**

Sizes                     Type

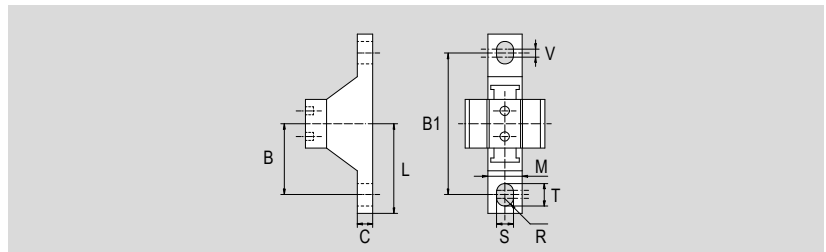

## Technical data

Type	Description	Material
ST..	"T" type bracket. Spare part for spacer with "T" type bracket type DST..	Painted aluminium

## Dimensions

Size	Code	Item	B	B1	C	L	M	R	S	T	V	Weight (g)
1/4"	090167	ST14	24	48	5	33	15	2,75	5,5	8,5	3	-
3/8"	090168	ST38	35	70	7	45	16	3,5	7	11	4	-
1/2"	090169	ST12	40	80	7	50	22	4,5	9	13	4	-
1"	090170	ST01	50	100	10,5	63	23	6	12	16	4	-



# Mounting accessories

## Mounting accessories for single components



### Main features

**1/4" ÷ 1"**     **SR..**  
 Sizes            Type

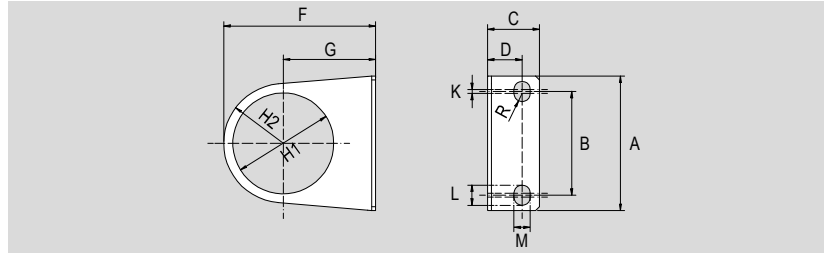

### Technical data

Type	Description	Material
SR..	Brackets for regulators and filter-regulators. Allow the panel mounting of the single component. Compatible with type A..R and A..FRR.	Zinc-plated steel

### Dimensions

Size	Code	Item	A	B	C	D	F	G	H1	H2	K	L	M	R	Weight (g)
1/4"	090141	SR14	55	34	25	19	50	30	33,5	20	1	15	5,4	2,7	-
3/8"	090142	SR38	53	40	21,5	14	64	39	42,5	25	1,5	8	6,5	3,25	-
1/2"	090143	SR1201	70	54	27	18	79,2	49,2	52,5	30	2	10,5	8,5	4,25	-
1"															

### Main features

**1/8" ÷ 1/4"**     **SR700**  
 Sizes            Type

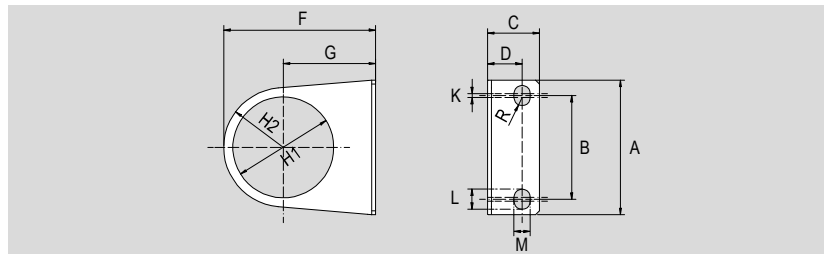

### Technical data

Type	Description	Material
SR700	Brackets for microregulators. Allow the panel mounting of the single component. Compatible with type AC700	Zinc-plated steel

### Dimensions

Size	Code	Item	A	B	C	D	F	G	H1	H2	K	L	M	R	Weight (g)
1/8"	090308	SR700	44,5	24	20	12	55,5	35,5	30	20	6	12	6	3	-
1/4"															

# Mounting accessories

Mounting accessories for single components



## Main features

1/8" ÷ 1/2" **SRP..**

Sizes Type

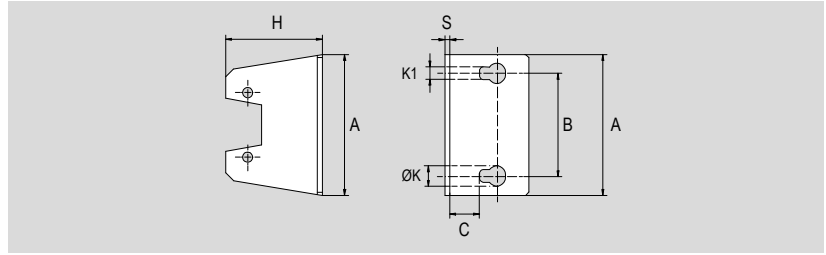

## Technical data

Type	Description	Material
SRP..	Brackets for precision regulators. Allow the panel mounting of the single component. Compatible with type A..RP	Zinc-plated steel

## Dimensions

Size	Code	Item	A	B	C	H	ØK	K1	S	Weight (g)
1/8"	090315	SRP18	42	28	7	25	8,5	4,5	2	20
1/4"	090316	SRP14	50	36	8	30	9,5	5,5	2	30
1/2"	090317	SRP12	82	60	5	23	15,5	9	2,3	50

## Main features

1/4" ÷ 1" **SFL..**

Sizes Type

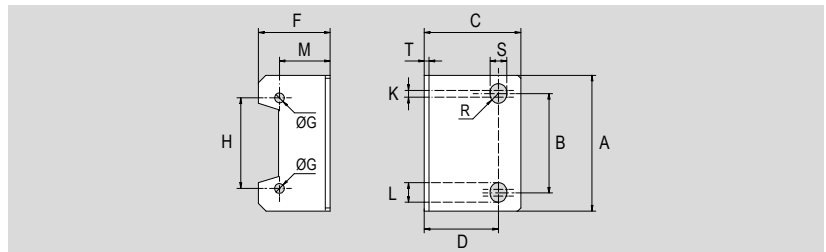

## Technical data

Type	Description	Material
SFL..	Brackets for filters, mist separators and lubricators. Allow the panel mounting of the single component. Compatible with type A..F, type A..FD and type A..L.	Zinc-plated steel

## Dimensions

Size	Code	Item	A	B	C	D	F	ØG	H	K	L	M	R	S	T	Weight (g)
1/4"	090144	SFL14	40	27	33	27	18	4,5	26	3	8,4	14	2,7	5,4	2,3	-
3/8"	090145	SFL38	53	40	39	32	22,5	4,5	35	1,5	8	19	3,25	6,5	2,3	-
1/2"	090146	SFL12	70	54	47	38	31,5	5,5	47	2	10,5	20	4,25	8,5	2,3	-
1"	090147	SFL01	90	66	64	52	43	6,5	60	2	13	29	5,5	11	3,2	-

3 - AIR TREATMENT



# Mounting accessories

Mounting accessories for digital pressure-gauges and vacuum-gauges



## Main features

1/8" ÷ 1/4" **ABT5**

Sizes Type

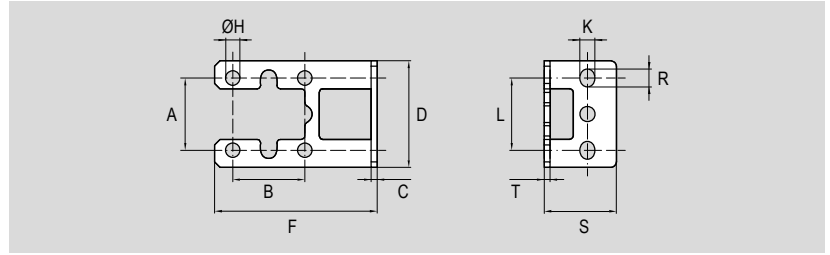

## Technical data

Type	Description	Material
ABT5	Straight mounting brackets for digital pressure-gauges and vacuum-gauges. Allow the panel mounting of the single component. Compatible with all series AKP60. The kit include two mounting screws for fixing the component to the bracket.	Zinc-plated steel

## Dimensions

Size	Code	Item	A	B	C	D	F	ØH	K	L	R	S	T	Weight (g)
1/8"	024807	ABT5	20	20	1,6	29,5	45	4	4,2	20	5	20	1,6	-
1/4"														

## Main features

1/8" ÷ 1/4" **ABT6**

Sizes Type

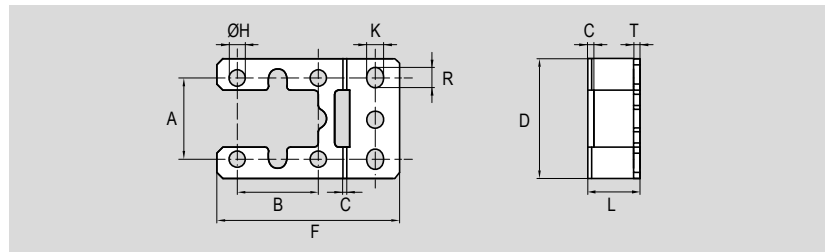

## Technical data

Type	Description	Material
ABT6	Type "L" mounting brackets for digital pressure-gauges and vacuum-gauges. Allow the panel mounting of the single component. Compatible with all series AKP60. The kit include two mounting screws for fixing the component to the bracket.	Zinc-plated steel

## Dimensions

Size	Code	Item	A	B	C	D	F	ØH	K	L	R	T	Weight (g)
1/8"	024808	ABT6	20	20	1,6	29,5	45	4	4,2	13	5	1,6	-
1/4"													

# Mounting accessories

## Mounting accessories for digital pressure switches



### Main features

**1/8"**      **AKP12**  
 Sizes      Type

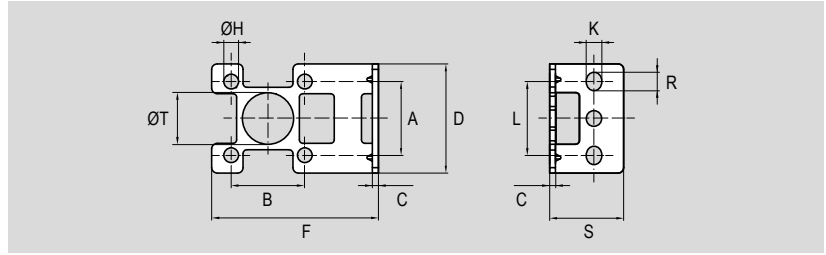

### Technical data

Type	Description	Material
AKP12	Straight mounting brackets pressure switches. Allow the panel mounting of the single component. Compatible with all series AKP43. The kit include two mounting screws for fixing the component to the bracket.	Zinc-plated steel

### Dimensions

Size	Code	Item	A	B	C	D	F	ØH	K	L	R	S	ØT	Weight (g)
1/8"	024816	AKP12	20	20	2	29,5	45	4	4,2	20	5	20	14	-

3 - AIR TREATMENT

### Main features

**1/8"**      **AKP13**  
 Sizes      Type

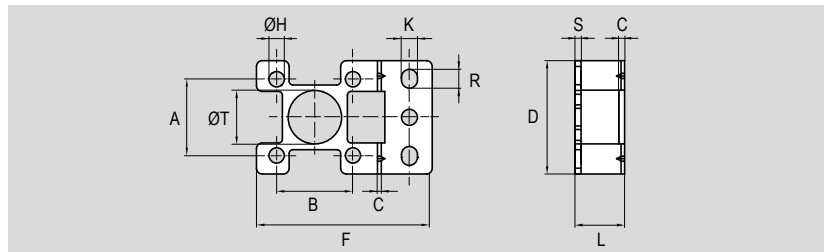

### Technical data

Type	Description	Material
AKP13	Type "L" mounting brackets pressure switches. Allow the panel mounting of the single component. Compatible with all series AKP43. The kit include two mounting screws for fixing the component to the bracket.	Zinc-plated steel

### Dimensions

Size	Code	Item	A	B	C	D	F	ØH	K	L	R	S	ØT	Weight (g)
1/8"	024817	AKP13	20	20	2	29,5	45	4	4,2	13	5	2	14	-

# Mounting accessories

Mounting accessories for digital pressure-gauges, vacuum-gauges and pressure switches



## Main features

1/8" ÷ 1/4" **APAC**

Sizes Type

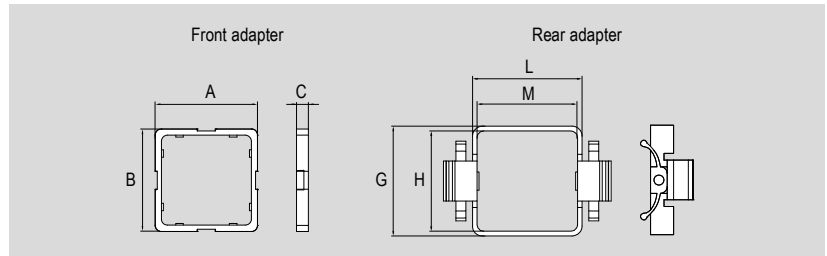

## Technical data

Type	Description	Material
APAC	Panel adapter for digital pressure-gauges, vacuum-gauges and pressure switches. Compatible with all series AKP60 and AKP43. Allow the panel mounting of the component, both single and multiple. For information about mounting, see page 3.30.41 (for series AKP60) and page 3.30.62 (for series AKP43).	Polymer

## Dimensions

Size	Code	Item	A	B	C	G	H	L	M	Weight (g)
1/8"	024809	APAC	34,4	34,4	4	33	30,2	33	30,2	-
1/4"										

## Main features

1/8" ÷ 1/4" **APAD**

Sizes Type

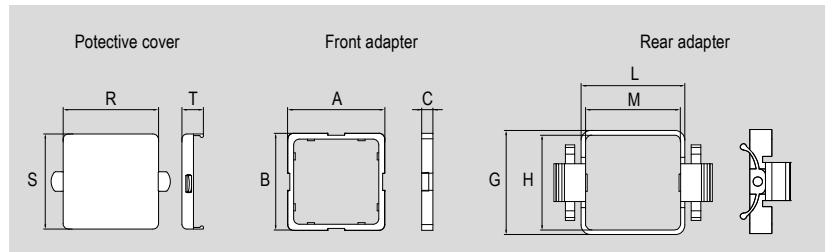

## Technical data

Type	Description	Material
APAD	Panel adapter with front protective liv for digital pressure-gauges, vacuum-gauges and pressure switches. Compatible with all series AKP60 and AKP43. Allow the panel mounting of the component, both single and multiple, also offering a screen protection. For information about mounting, see page 3.30.41 (for series AKP60) and page 3.30.62 (for series AKP43).	Polymer

## Dimensions

Size	Code	Item	A	B	C	G	H	L	M	R	S	T	Weight (g)
1/8"	024802	APAD	34,4	34,4	4	33	30,2	33	30,2	34,4	34,4	8,5	-
1/4"													