



CYLINDERS

CHAPTER 1



General informations

Cylinders technical features	Page 1.1.1
------------------------------	------------

Cylinders conforming to standards

Series		Type	Page
ISO 6432		MS, MSM, MD, MDM, MDMA	1.2.1
ISO 15552		AMA, AMT, BMA, BMT	1.5.1
CNOMO		CX, CM	1.14.1
Compact ISO 21287		CIS, CI	1.16.1
Compact UNITOP		CS, CD	1.17.1

Cylinders not conforming to standards

Series		Type	Page
Round		MSM, MDM, MDMA, RS, RD, RMD, RDMA	1.10.1
Compact		DU, DUM	1.18.1
Short stroke		BS, BSM, BD, BDM	1.20.1
Compact CL		CLS, CLSM, CLD, CLDM	1.21.1
Compact guided		GEDB, GEDS, GPB, GPS	1.23.1
Twin-rod		GSB, GSS	1.24.1
Rodless		S1, S2, S3, S4, S5, S6	1.26.1
Cartridge		MCF, MCN	1.55.1

Rotary cylinders and actuators

Series		Type	Page
Rotary cylinders		CRTH, CRTHD, CRTF	1.40.1
Rotary vane cylinders		ARTM, ARTMF	1.50.1
Rotary actuators		ARC, ARP	1.52.1

Hand grips

Series		Type	Page
Angular hand grips		PAB, PAC	1.60.1
Parallel hand grips		PPB, PPC, PPD, PPE	1.60.1

Accessories for cylinders

Accessories for cylinders			Page
Description			
Slide units		For cylinders ISO 6432 and ISO 15552	1.70.1
Piston rod brake		For cylinders ISO 6432 and ISO 15552	1.75.1
Clevis		Conforming to ISO, DIN and CNOMO standards	1.85.1
Bearings		Bearing heads	1.85.1
Couplings		Self-aligning articulated, axial and angular couplings	1.85.1
Other rod accessories		Nipples e rod nuts	1.85.1
Shock absorbers		DR, DRF	1.105.1
Magnetic reed switches and cables		For T and C grooves, high temperatures and conforming to Atex	1.110.1
Brackets for magnetic reed switches		AFM, AFR, AS	1.110.1

Mountings for cylinders Page 1.94.1

Mountings for cylinders			Page
Description			
Mountings for cylinders ISO 6432		In steel	1.95.1
Mountings for round cylinders		In steel	1.96.1
Mountings for cylinders ISO 15552		In aluminium	1.97.1
		In steel	1.98.1
Mountings for cylinders CNOMO		In aluminium	1.99.1
		In steel	1.99.50
Mountings for compact cylinders ISO 21287		In aluminium	1.100.1
		In steel	1.100.50
Mountings for compact cylinders UNITOP		In aluminium	1.100.100
		In steel	1.100.150
Mountings for short stroke cylinders		In aluminium	1.100.200
Mountings for rodless cylinders		In aluminium	1.100.250
Mountings for hand grips		In aluminium	1.100.350
Brackets for slide units		In aluminium	1.100.400
Screws, nuts and growers		In steel	1.101.1

Definition and main features

The pneumatic cylinder is an engine that uses pneumatic energy, transforming it into mechanical work by means of rectilinear movement. It is composed of a barrel, closed at the ends by two heads, within which a piston moves, separating two chambers. The piston is equipped with a rod that, when exiting through one or both of the heads, permits the exploitation of the force developed by the cylinder.

The characteristic parameters of a cylinder are:

- Bore = internal diameter of the [mm]
- Stroke = working movement to be performed [mm]
- Diameter of the piston rod = closely correlated to the bore [mm]
- Number of actings = number of strokes per cycle during which work is performed. These may be either one (single acting); or two (double acting).
- Operating pressure range [bar]
- Operating temperature range [°C]
- Translation velocity [m/s]
- Number of adjustable end cushionings
- Kinetic energy absorbed by the cushionings [Nm]
- Air consumption [nl/min]
- Theoretical force [N]

Bore Ø	Pressure range P	Piston rod diameter d	Stroke c
A finite number of bores are available, all of which are standardized. The range goes from bores measuring just a few millimetres to those of 320 mm	This value is not very variable, due to technical-economical reasons. It covers the range 5 ÷ 7 bar. A system operating at 6 bar is considered optimized.	This is standardized for all the available bores.	The most frequently requested strokes are available in our warehouse. Any technically compatible stroke can be supplied in a short time. It is advisable to choose easily available strokes that are greater than the operating strokes, halting the stroke at the desired value by means of external mechanical stops, in order to obtain mechanical precision and greater durability of the cylinder.

Operating temperature range

Ambient temperature must not be such as to make the cylinder assume values outside the temperature range for which it was constructed. It is possible to construct cylinders that are resistant to very low or very high temperatures, using special materials. The catalogues always show the operating temperature range.

The cylinder can also reach high temperatures due to particular conditions of use: in general, when the friction between the tube and the mobile apparatus increases greatly (e.g. due to high speeds with insufficient lubrication, the exhaustion of assembly lubrication or excessive compression of the air). The seals of the cylinder are the most short-lived component and those that are most sensitive to temperature.

Translation velocity v

It is advisable to adjust the translation velocity by means of the air discharge. The movement of the piston is fairly regular even with minimum velocities of 40 mm/s. The maximum velocity acceptable without additional lubrication to assembly lubrication, is equivalent to 1000 mm/s. Velocities of 2 ÷ 3 m/s can be reached with appropriate lubrication. For high velocities, as for high masses, the kinetic energy to be reabsorbed is excessive for the air cushionings. It is necessary to use external hydraulic cushionings of an appropriate size.

Theoretical force Ft

The theoretical force generated by a cylinder can be calculated by multiplying the actual area of the piston subjected to pressure by the operating pressure. For cylinders during pushing, the effective area of the piston corresponds to the bore:

$$F_t = \pi \Phi^2 p / 40 \text{ [N]}$$

Φ = bore [mm]
 P = operating pressure [bar]

N.B.: the formula considers passages from bars to N/m² and from mm² to m².

For cylinders in traction, it is necessary to subtract the area of the rod from that of the piston:

$$F_t = \pi (\Phi^2 - d^2) p / 40 \text{ [N]}$$

Motion force F

The available motion force to the piston rod is:
 $F = Ft - R$
 Where R represents a force of reaction that comprises numerous factors: friction, form and type of seals, operating pressure, counter-pressure at discharge. The value of R is not easy to quantify as its component factors are not only numerous, but also variable. A cautious estimate for usual applications could be 30% Ft.
 As shown by the graph illustrated below, which indicates the progress of the pressure values of delivery and discharge during the uniform movement of a cylinder, the delivery value Pm and the discharge value Ps remain constant during the stroke of the cylinder, if we exclude the brief transitory periods: of acceleration following the switching of the distributing valve and cushion at the end of the stroke.
 The cylinder is thus prevalently subject to a motion force F proportional to Pm and the pushing surface, and to a counter-pressure force Fs proportional to the pressure Ps and the section upon which it acts, both of which are constant. The load reaction Fc must be added to these two forces.
 In other words, the cylinder, in dynamic equilibrium, will - like all engines in this state - find itself under the action of contrasting forces that balance each other. It will move at a constant speed under the action of a constant force.
 $Ft - Fs - Fa = Fc$ Where Fs is the counter-pressure force and Fa is a force that bears in mind the friction and reduction of the operating power, to which Ft is linked, which does not reach the static network pressure, as can be seen in the graph.
 During the transitory acceleration period, the force Fs is very low, as the air is being discharged. As the speed of the piston increases, the air being discharged is compressed and the force Fs increases until the state of equilibrium is reached.
 For example, we wish to find the cylinder capable of overcoming the load value **$Fc = 1200$ [N]**
 The theoretical force Ft must be at least 30% greater. Let's assume that: **$Ft = 1600$ [N]**
 This gives the following result:

$$\Phi = \sqrt{40Ft/\pi p} \quad \Phi = \sqrt{40 \times 1600 / (3,14 \times 6)} \quad \cong 58$$
 [mm]
 The closest standardized bores turn out to be: 50 mm and 63 mm It is advisable to choose the bore $\Phi = 63$ mm, also because it enables a reserve of power to be obtained.
 The uniform movement of the cylinder can be obtained by regulating the air at the discharge.
 In order to obtain high values, on the other hand, it is necessary to make an appropriate increase in the discharge space in order to obtain accelerated movements, as the equilibrating force of counter-pressure is no longer present.

Peak load

In the case of long strokes, the load that can be applied to the piston rod is reduced due to the decrease in resistance at peak load.
 The lifespan of a cylinder depends largely on its mechanical application. Installation must be performed in such a way as to avoid, or at least minimize, bending moments and radial loads on the piston rod (the most onerous kind of anchorage is the hinge type).
 If only axial loads need be applied, the piston rod will be subjected to the peak load during pushing.
 As the acceptable peak load is proportional to the diameter of the piston rod d (through the elastic modulus and the inertia moment) and inversely proportional to twice the stroke (length of free inflexion), in the case in which it does not allow the application of the required force, it is necessary to increase the diameter of the piston rod, passing to a suitably larger bore.
 The choice of the standardized bore that best satisfies the requirements of the application in question is not just linked to the satisfaction of the force to be provided, but also to that of other conditions. These include the need to always have a power reserve (by choosing a larger size) and that of not causing excessive stress to the cushionings.

Air consumption l/min

Air consumption air is a working value; it has a significant influence on costs. It is possible to calculate the average air consumption using the following formula:

$$Q = \pi \Phi^2 / 4 \times 60 \text{ c/t} \times (p+p_0) / p_0 \times 10^{-3} \times 10^{-3}$$
 [nl/min]
 Where:
 Q = air consumption [nl/min]
 Φ = bore [mm]
 c = stroke [mm]
 t = time taken to perform the stroke [s]
 p = atmospheric operating pressure [bar]
 p0 = atmospheric pressure: 1 bar
 For example, we want to calculate the consumption of the following cylinder:
 d = 50 mm; c = 300 mm; t = 0,45 s; p = 6 bar

$$Q = 3,14 \times 25 \times 10^2 / 4 \times (60 \times 3 \text{ w } 10^2 / 0,45) \times 7 \times 10^{-3} \times 10^{-3} = 550$$
 [nl/min]

Piston force F

The piston force (F) can be determined on the basis of the following formulae relating to the area of the piston rod (A), operating pressure (p) and friction (R).

$$\text{Piston force } F = a \cdot p - R$$

$$\text{(final pressure) } F = p \cdot 10 \frac{d^2 \cdot \pi \cdot 10}{4} - R$$

- p = bar
- d = bore (mm)
- R = friction = 10% (N)
- A = area of piston rod
- F = actual force of piston (N)

Theoretical cylinders force

Pressure range / Piston force (N)

Bore Ø mm	Operating pressure bar									
	1	2	3	4	5	6	7	8	9	10
6	2,5	5,1	7,6	10,2	12,7	15,3	17,8	20,4	22,9	25,4
8	4,5	9,0	13,6	18,1	22,6	27,1	31,7	36,2	40,7	45,2
10	7,1	14,1	21,2	28,3	35,3	42,4	49,5	56,5	63,6	70,7
12	10,2	20,4	30,5	40,7	50,9	61,0	71,3	81,4	91,6	101
16	18,1	36,2	54,3	72,4	90,5	109	127	145	163	181
20	28,3	56,5	84,8	113	141	170	198	226	254	283
25	44,2	88,4	133	177	221	265	309	353	398	442
32	72,3	145	217	290	362	434	507	579	651	724
40	113	226	339	452	565	679	792	905	1020	1130
50	177	353	530	707	884	1060	1240	1410	1590	1770
63	281	561	842	1120	1400	1680	1960	2240	2520	2810
80	452	905	1360	1810	2260	2710	3170	3620	4070	4520
100	707	1410	2120	2830	3530	4240	4950	5650	6360	7070
125	1100	2210	3310	4420	5520	6630	7730	8840	9940	11000
160	1810	3620	5430	7240	9050	10900	12700	14500	16300	18100
200	2830	5650	8480	11300	14100	17000	19800	22600	25400	28300
250	4420	8840	13300	17700	22100	26500	30900	35300	39800	44200
320	7240	14500	21700	29000	36200	43400	50700	57900	65100	72400

CYLINDERS

ISO 6432



Find out our
key products



Solution for most applications



Easy and intuitive choice



Excellent value for money



Wide availability



Fast delivery



Features and certifications

Series of cylinders conforming to ISO 6432 standards, available in bores from Ø 8 to 25, single or double acting, magnetic or non-magnetic. The heads joined to the barrel through rolling ensure perfect tightening. Supplied as standard in compliance with Reach and RoHS directives, and SIL certificated. On request, they can be also supplied according to the 2014/34/EU ATEX Directive.



Type MS Ø 8 ÷ 25 from page 1.2.20



Cylinders conforming to ISO 6432 standards, available in bores from Ø 8 to 25, single acting, non magnetic, the heads joined to the barrel through rolling ensure perfect tightening. Equipped with rubber bumpers to cushion the impact of the piston. Complete with head nut and rod nut.

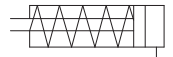

Type MSM Ø 8 ÷ 25 from page 1.2.20



Cylinders conforming to ISO 6432 standards, available in bores from Ø 8 to 25, single acting, magnetic, the heads joined to the barrel through rolling ensure perfect tightening. Equipped with rubber bumpers to cushion the impact of the piston. Possibility of applying one or more magnetic reed switches. Complete with head nut and rod nut.

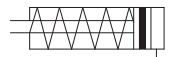

Type MD Ø 8 ÷ 25 from page 1.2.50



Cylinders conforming to ISO 6432 standards, available in bores from Ø 8 to 25, double acting, non magnetic, the heads joined to the barrel through rolling ensure perfect tightening. Equipped with rubber bumpers to cushion the impact of the piston. Complete with head nut and rod nut.

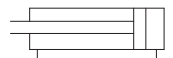

Type MDM Ø 8 ÷ 25 from page 1.2.50



Cylinders conforming to ISO 6432 standards, available in bores from Ø 8 to 25, double acting, magnetic, the heads joined to the barrel through rolling ensure perfect tightening. Equipped with rubber bumpers to cushion the impact of the piston. Possibility of applying one or more magnetic reed switches. Complete with head nut and rod nut.

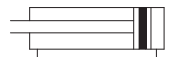

Type MDMA Ø 16 ÷ 25 from page 1.2.70



Cylinders conforming to ISO 6432 standards, available in bores from Ø 16 to 25, double acting, magnetic, the heads joined to the barrel through rolling ensure perfect tightening. Equipped with adjustable air cushioning on both ends. Possibility of applying one or more magnetic reed switches. Complete with head nut and rod nut.

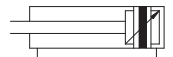





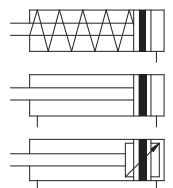

Types MSM, MDM and MDMA Ø 32 ÷ 63 from page 1.10.1



Round cylinders not conforming to standards, available in bores from Ø 32 to 63, magnetic, single acting (type MSM), double acting (type MDM) or double acting with cushions (type MDMA). The heads are joined to the barrel through rolling ensure perfect tightening. Possibility of applying one or more magnetic reed switches. Complete with head nut and rod nut.



Options		
Description	Symbol	Suffix
Through rod (available from Ø 16)		P
Rear spring (available only for MS and MSM type, from Ø 16)		T
Extended rod in hardened and chrome plated steel suitable for static piston rod brake (available from Ø 20)		B
FKM seals -20°C ÷ +150°C		V
Anti-rotating hexagonal rod (available from Ø 16)		Q
ATEX versions on request		/ATEX
Special versions on request		/S

The options, when this is possible, can be combined with each other. For options matching see page 1.2.4; For code key see page 1.2.5.

Options matching

Series	Bore	Model	Standard options matching					
			P (Ø16÷25)	T (Ø16÷25)	V	B (Ø20÷25)	Q (Ø16÷25)	/ATEX
MS-MSM	Ø 8 ÷ 25	Standard	●	●	●	●	●	●
	Ø 16 ÷ 25	Through rod (P)		-	●	●	●	●
		Rear spring (T)	-		●	●	●	●
	Ø 20 ÷ 25	Piston rod brake (B)	●	●	●		-	-
	Ø 16 ÷ 25	Anti-rotating rod (Q)	●	●	●	-		●
MD-MDM	Ø 8 ÷ 25	Standard	●	-	●	●	●	●
	Ø 16 ÷ 25	Through rod (P)		-	●	●	●	●
	Ø 20 ÷ 25	Piston rod brake (B)	●	-	●		-	-
	Ø 16 ÷ 25	Anti-rotating rod (Q)	●	-	●	-		●
MDMA	Ø 16 ÷ 25	Standard	●	-	●	●	●	●
		Through rod (P)	-	-	●	●	●	●
	Ø 20 ÷ 25	Piston rod brake (B)	●	-	●	-	-	-
	Ø 16 ÷ 25	Anti-rotating rod (Q)	●	-	●	-		●

Key
 ● allowed matching; - not allowed matching

Standard materials

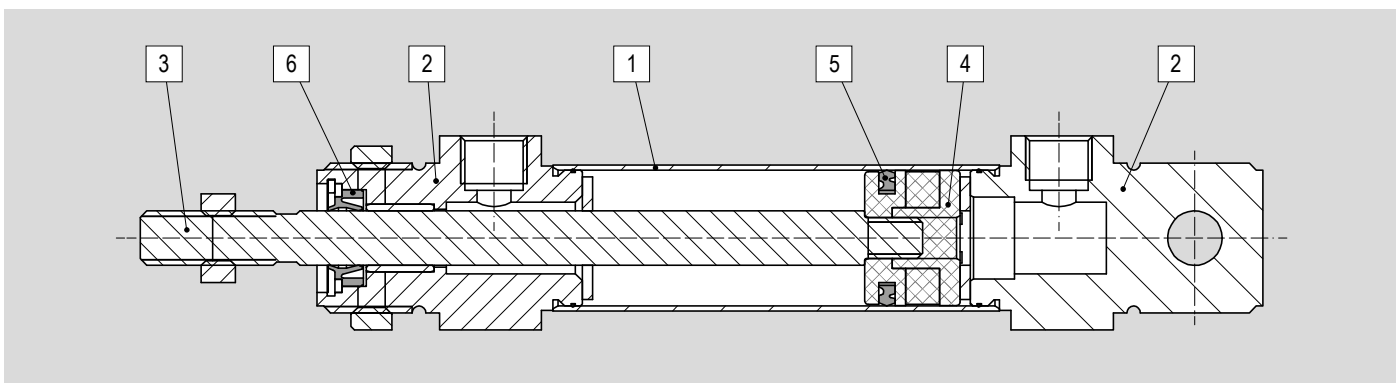

Position	Description	Materials
1	Tube	Stainless Steel AISI 316
2	Heads	Anodised aluminium
3	Rod	Stainless Steel AISI 304
4	Piston	Anodised aluminium
5	Piston seal	NBR
6	Rod seal	Polyurethane (PU)

Code key

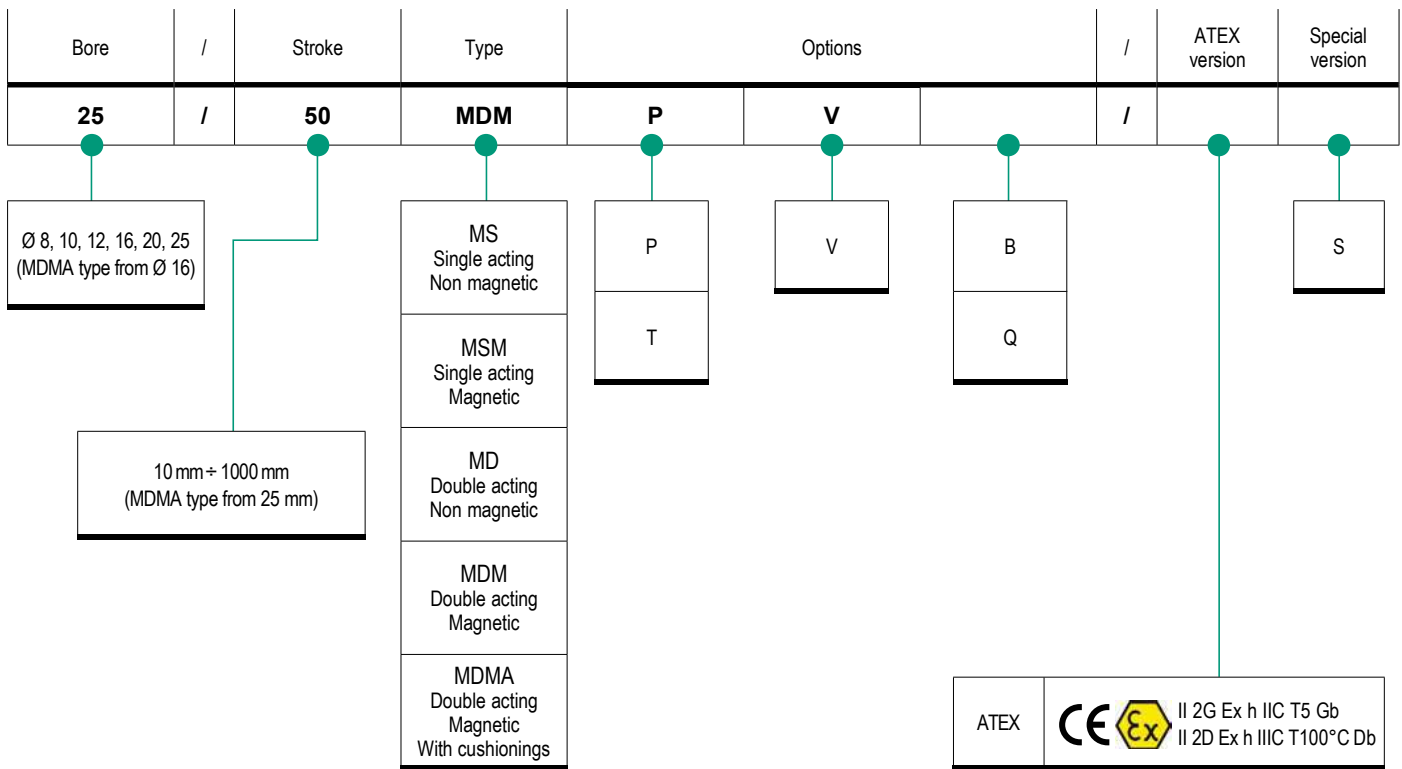

How to order

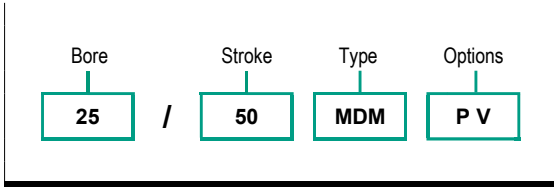

Notes

Options in the same grid are alternative to each others.

For further information on options and their matching, see page 1.2.3 and page 1.2.4

For further information on the ATEX 2014/34/EU Directive, on classifications and protections, see from page III.1

Accessories

1 - CYLINDERS

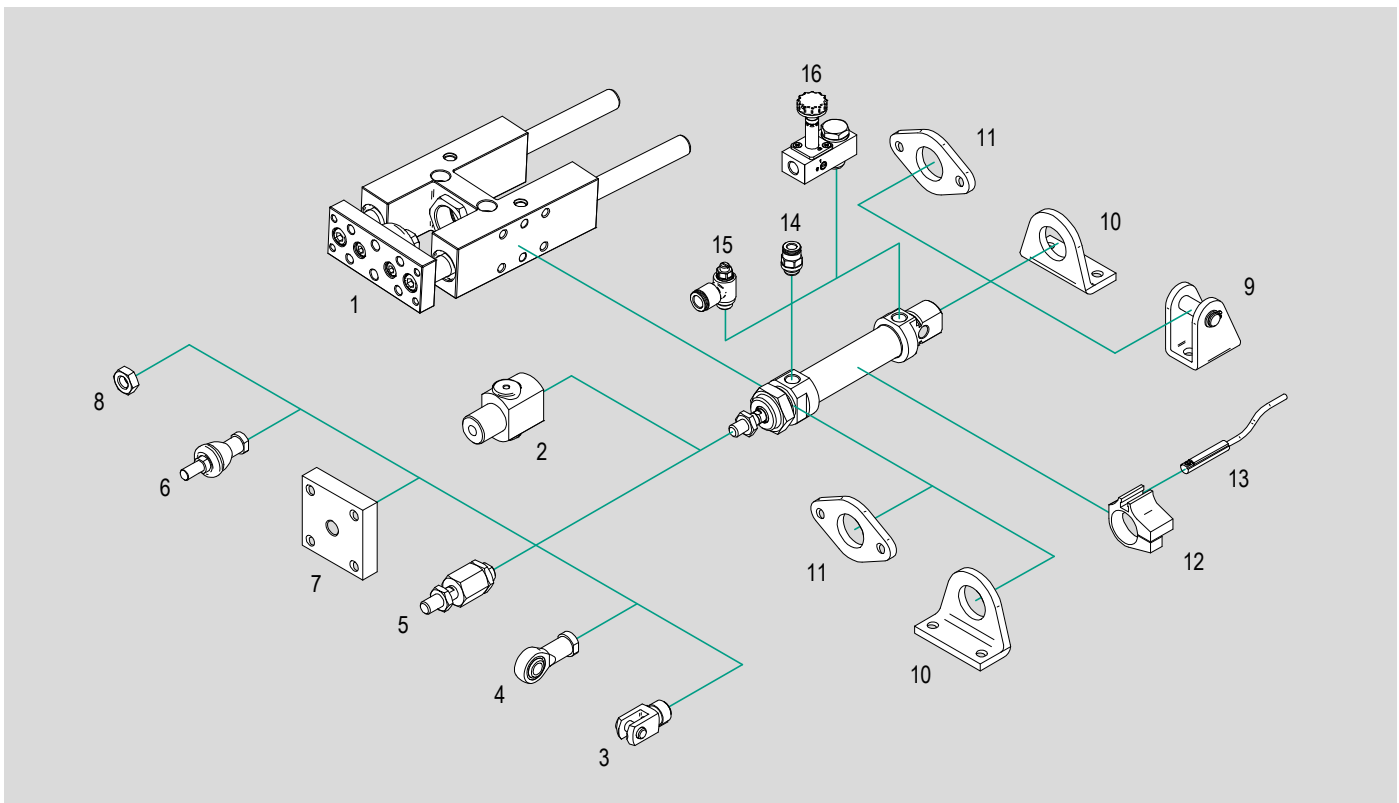

N.	Cylinder bore	Item	Description	Compliance	Matching					Code page	Data sheet page
					MS	MSM	MD	MDM	MDMA		
1	Ø 12 ÷ 25	UGLB	Slide unit U-shaped	-	●	●	●	●	●	1.70.1	
		UGPB UGPS	Slide unit H-shaped		●	●	●	●	●		
2	Ø 20 ÷ 25	ABS	Static piston rod brake	-	●	●	●	●	●	1.75.1	
3	Ø 8 ÷ 25	FF..	ISO female clevis with clip	ISO 8140	●	●	●	●	●	1.2.90	1.85.10
		FFP..	ISO female clevis with pin and seeger		●	●	●	●	●		
		FFN..	ISO female clevis (body only)		●	●	●	●	●		
4	Ø 8 ÷ 25	RF..SE	Bearing head (DIN 648K) with female thread	ISO 8139	●	●	●	●	●	1.90.1	
5	Ø 8 ÷ 25	GB..	Bearing - Self-aligning articulated coupling	-	●	●	●	●	●	1.90.10	
6	Ø 12 ÷ 25	RBI..	Bearing - Axial articulated coupling	-	●	●	●	●	●	1.2.91	1.90.20
		RBL..	Bearing - Angular articulated coupling		●	●	●	●	●		1.90.30
7	Ø 25	GC..	Self-aligning coupling	-	●	●	●	●	●	1.90.40	
8	Ø 8 ÷ 25	D..	Rod nut	UNI 5589	●	●	●	●	●	1.90.70	
9	Ø 8 ÷ 25	CF..	Rear clevis	ISO MP3	●	●	●	●	●	1.95.1	
10	Ø 8 ÷ 25	P..	High foot	ISO MS3	●	●	●	●	●	1.95.2	
11	Ø 8 ÷ 25	F..	Flange	ISO MF8	●	●	●	●	●	1.95.2	
12	Ø 8 ÷ 25	AFM..	Bracket for T type magnetic reed switches	-	-	●	-	●	●	1.120.1	
13	Ø 8 ÷ 25	ASV..	Magnetic reed switch T groove	-	-	●	-	●	●	1.110.10	
		MK..	ATEX magnetic reed switch T groove	2014/34/EU	-	●	-	●	●	1.113.1	
14	Ø 8 ÷ 25	R..	Push-in fittings	-	●	●	●	●	●	4.2.1	
15	Ø 8 ÷ 25	V..C	Flow controls, for cylinders	-	●	●	●	●	●	4.94.1	
16	Ø 20 ÷ 25	A1E1..MD	22mm direct mounting solenoid valves	-	●	●	-	-	-	1.2.90	2.10.1

Key
 ● matching accessory; - not matching accessory

Main features

8 ÷ 25

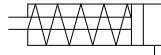

MS

Bores Ø

Single acting
Non magnetic

Type



8 ÷ 25

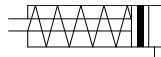

MSM

Bores Ø

Single acting
Magnetic

Type



Technical data

Bore Ø mm	8	10	12	16	20	25													
Fluid	Filtered compressed air with or without lubrication. Lubrication, if started, must be continued.																		
Pressure range	1 ÷ 10 bar																		
Temperature range	-20°C ÷ +80°C (standard)									-20°C ÷ +150°C (V)									
Strokes	10 ÷ 50 mm																		
Ports	M5													1/8"					
Rod thread	M4						M6						M8			M10x1,25			
Thrust force at 6 bar (N)	20			35			50			90			148			250			
Traction force (N)	Stroke (mm)	10	25	50	10	25	50	10	25	50	10	25	50	10	25	50	10	25	50
	min.	4,8	4	3,2	4,8	4	3,2	6,3	5,4	3,9	13,1	11,8	9,7	18,1	16,4	13,4	22,9	21,1	17,7
	max.	5,3	5,3	5,3	5,3	5,3	5,3	6,9	6,9	6,9	14	14	14	19,4	19,4	19,4	23,9	23,9	23,9

Standard strokes

Stroke mm	MS Bore Ø mm					
	8	10	12	16	20	25
10						
25						
50						

Stroke mm	MSM Bore Ø mm					
	8	10	12	16	20	25
10						
25						
50						

Key
 Standard stroke

Standard dimensions

Type: **MS - MSM**

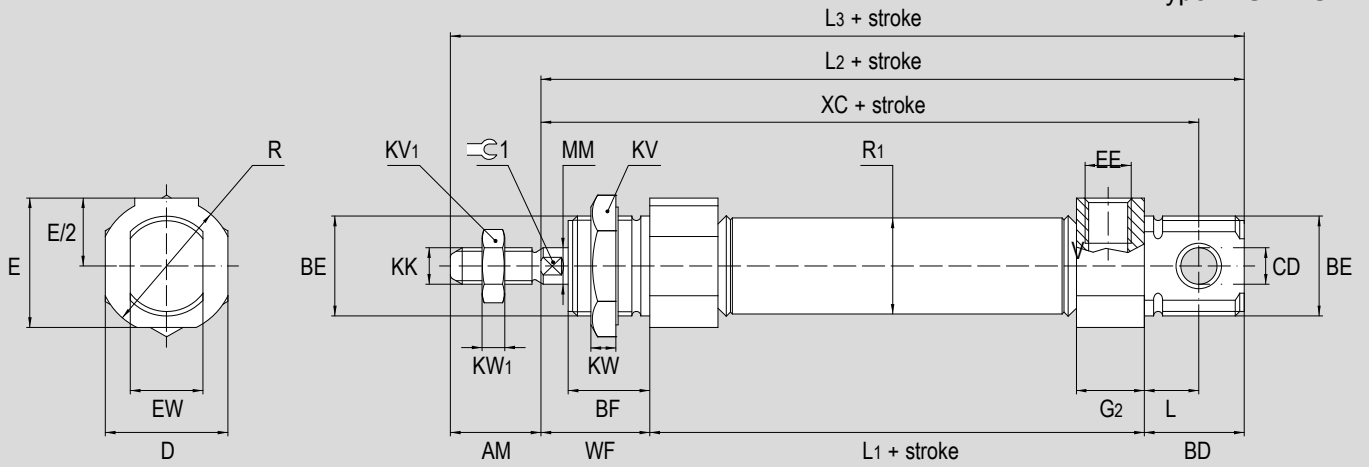

∅ (mm)	KK	MM	BE	R	EW	R ₁	E	CD	AM	XC	L ₂	L
8	M4x0,7	4	M12x1,25	16	8	9,27	15	4	12	64	74	4
10	M4x0,7	4	M12x1,25	16	8	11,27	15	4	12	64	74	4
12	M6x1	6	M16x1,5	21	12	13,27	18	6	16	75	89	2
16	M6x1	6	M16x1,5	21	12	17,27	19	6	16	82	96	2
20	M8x1,25	8	M22x1,5	30	16	21,27	28,5	8	20	95	105	12
25	M10x1,25	10	M22x1,5	30	16	26,5	28,5	8	22	104	114	12

∅ (mm)	L ₁	WF	BF	BD	EE	L ₃	D	KW	KW ₁	⌀1	KV ₁	KV	E/2	G ₂
8	46	16	12	12	M5	86	16	7	3	-	7	19	7,5	9
10	46	16	12	12	M5	86	16	7	3	-	7	19	7,5	9
12	51	22	16	16	M5	105	19	8	3,5	5	10	24	10	10
16	58	22	16	16	M5	112	19	8	3,5	5	12	24	10	10
20	59	24	18	22	G1/8"	125	27	6	5	7	14	27	15	15
25	64	28	20	22	G1/8"	136	27	6	6	9	17	27	15	16

Dimensions with options

Type: ...P

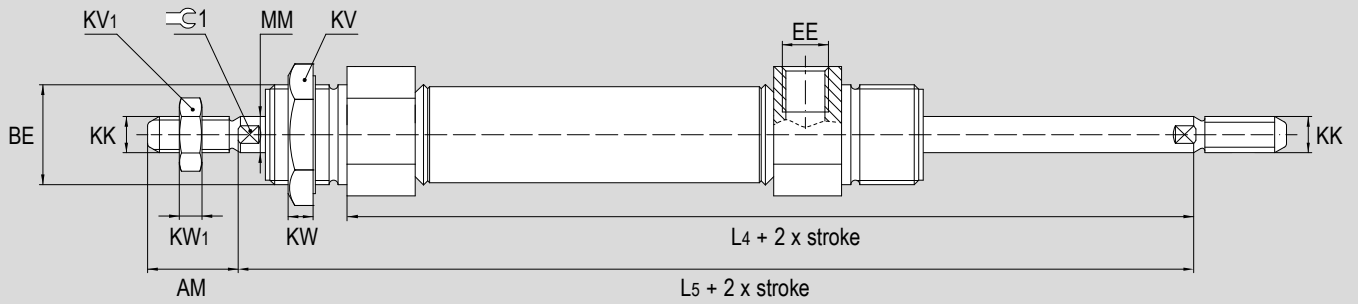

Type: ...B

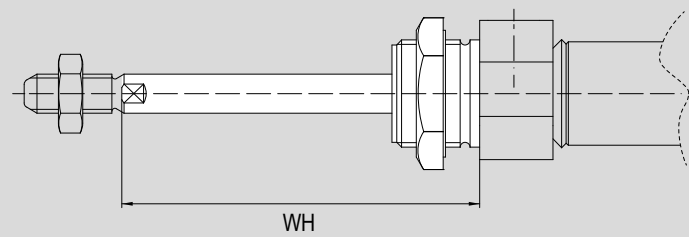

Ø mm	L ₄	L ₅	EE	BE	KK	KW	KW ₁	☞ 1	KV ₁	KV	MM	AM	WH
16	80	102	M5	M16x1,5	M6x1	8	3,5	5	12	24	6	16	-
20	83	107	G1/8"	M22x1,5	M8x1,25	6	5	7	14	27	8	20	72
25	92	120	G1/8"	M22x1,5	M10x1,25	6	6	9	17	27	10	22	74

Main features

8 ÷ 25

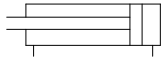

MD

Bores Ø

Double acting
Non magnetic

Type



8 ÷ 25

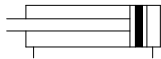

MDM

Bores Ø

Double acting
Magnetic

Type



Technical data

Bore Ø mm	8	10	12	16	20	25
Fluid	Filtered compressed air with or without lubrication. Lubrication, if started, must be continued.					
Pressure range	1 ÷ 10 bar					
Temperature range	-20°C ÷ +80°C (standard)		-20°C ÷ +150°C (V)			
Strokes	10 ÷ 200 mm		10 ÷ 320 mm		10 ÷ 1000 mm	
Ports	M5				1/8"	
Rod thread	M4		M6		M8	M10x1,25

Standard strokes

Stroke mm	MD Bore Ø mm					
	8	10	12	16	20	25
10						
25						
50						
80						
100						
125						
160						
200						
250						
320						
400						
500						

Stroke mm	MDM Bore Ø mm					
	8	10	12	16	20	25
10			Key	Key	Key	Key
25			Key	Key	Key	Key
50			Key	Key	Key	Key
80			Key	Key	Key	Key
100			Key	Key	Key	Key
125			Key	Key	Key	Key
160			Key	Key	Key	Key
200			Key	Key	Key	Key
250					Key	Key
320					Key	Key
400						
500						

Key
 Standard stroke

Standard dimensions

Type: MD - MDM

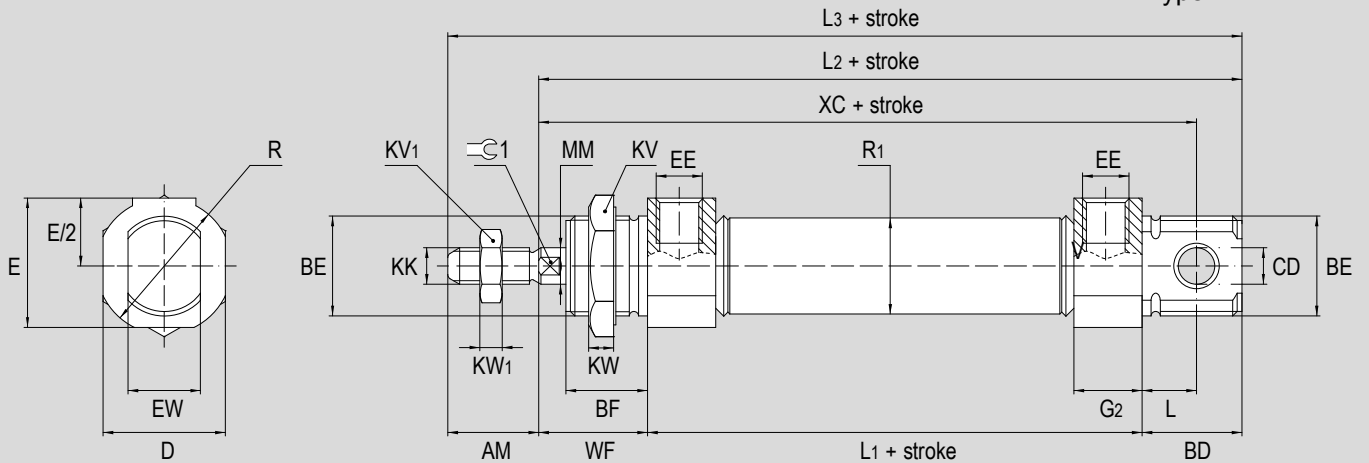

Ø (mm)	KK	MM	BE	R	EW	R ₁	E	CD	AM	XC	L ₂	L
8	M4x0,7	4	M12x1,25	16	8	9,27	15	4	12	64	74	4
10	M4x0,7	4	M12x1,25	16	8	11,27	15	4	12	64	74	4
12	M6x1	6	M16x1,5	21	12	13,27	18	6	16	75	89	2
16	M6x1	6	M16x1,5	21	12	17,27	19	6	16	82	96	2
20	M8x1,25	8	M22x1,5	30	16	21,27	28,5	8	20	95	105	12
25	M10x1,25	10	M22x1,5	30	16	26,5	28,5	8	22	104	114	12

Ø (mm)	L ₁	WF	BF	BD	EE	L ₃	D	KW	KW ₁	1	KV ₁	KV	E/2	G ₂
8	46	16	12	12	M5	86	16	7	3	-	7	19	7,5	9
10	46	16	12	12	M5	86	16	7	3	-	7	19	7,5	9
12	51	22	16	16	M5	105	19	8	3,5	5	10	24	10	10
16	58	22	16	16	M5	112	19	8	3,5	5	12	24	10	10
20	59	24	18	22	G1/8"	125	27	6	5	7	14	27	15	15
25	64	28	20	22	G1/8"	136	27	6	6	9	17	27	15	16

Dimensions with options

1 - CYLINDERS

Type: ...P

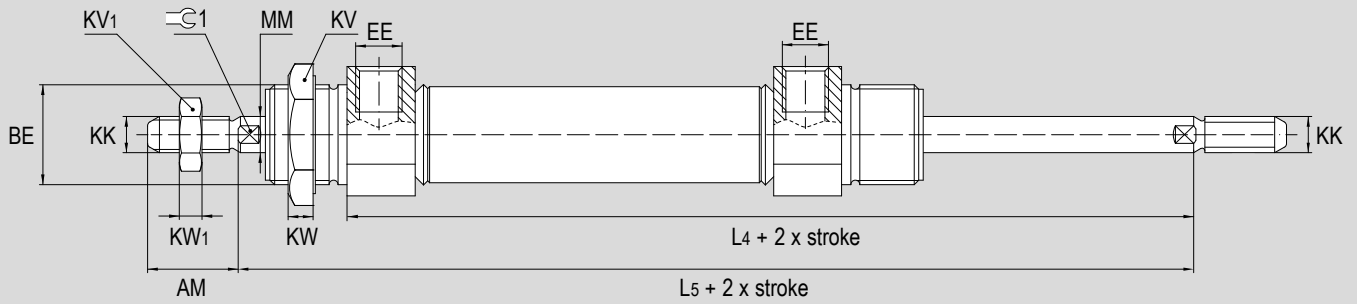

Type: ...B

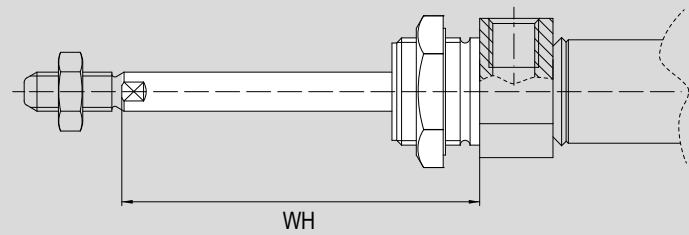

Ø mm	L ₄	L ₅	EE	BE	KK	KW	KW ₁	1	KV ₁	KV	MM	AM	WH
16	80	102	M5	M16x1,5	M6x1	8	3,5	5	12	24	6	16	-
20	83	107	G1/8"	M22x1,5	M8x1,25	6	5	7	14	27	8	20	72
25	92	120	G1/8"	M22x1,5	M10x1,25	6	6	9	17	27	10	22	74

Main features

16 ÷ 25

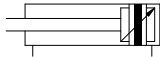

MDMA

Bores Ø

Double acting
Magnetic
With cushioning

Type



Technical data

Bore Ø mm	16	20	25
Fluid	Filtered compressed air with or without lubrication. Lubrication, if started, must be continued.		
Pressure range	1 ÷ 10 bar		
Temperature range	-20°C ÷ +80°C (standard)	-20°C ÷ +150°C (V)	
Strokes	25 ÷ 1000 mm		
Ports	M5	1/8"	
Rod thread	M6	M8	M10x1,25

Standard strokes

Stroke mm	MDMA Bore Ø mm		
	16	20	25
25			
50			
80			
100			
125			
160			
200			
250			
320			
400			
500			

Key
 Standard stroke

Standard dimensions

Type: **MDMA**

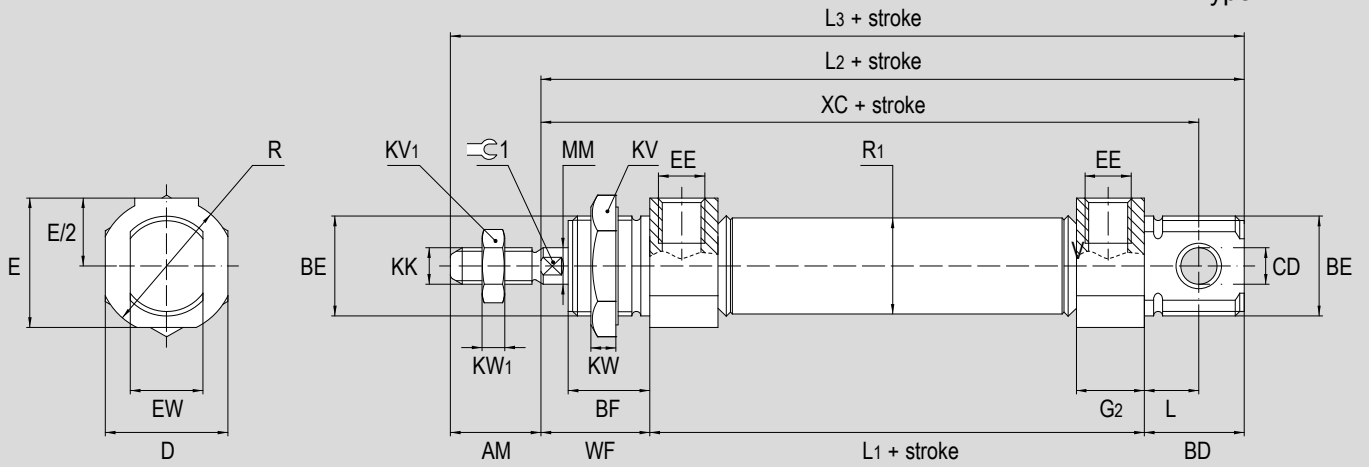

∅ (mm)	KK	MM	BE	R	EW	R ₁	E	CD	AM	XC	L ₂	L
16	M6x1	6	M16x1,5	21	12	17,27	19	6	16	82	96	2
20	M8x1,25	8	M22x1,5	30	16	21,27	28,5	8	20	95	105	12
25	M10x1,25	10	M22x1,5	30	16	26,5	28,5	8	22	104	114	12

∅ (mm)	L ₁	WF	BF	BD	EE	L ₃	D	KW	KW ₁	⌀1	KV ₁	KV	E/2	G ₂
16	58	22	16	16	M5	112	19	8	3,5	5	12	24	10	10
20	59	24	18	22	G1/8"	125	27	6	5	7	14	27	15	15
25	64	28	20	22	G1/8"	136	27	6	6	9	17	27	15	16

Dimensions with options

Type: ...P

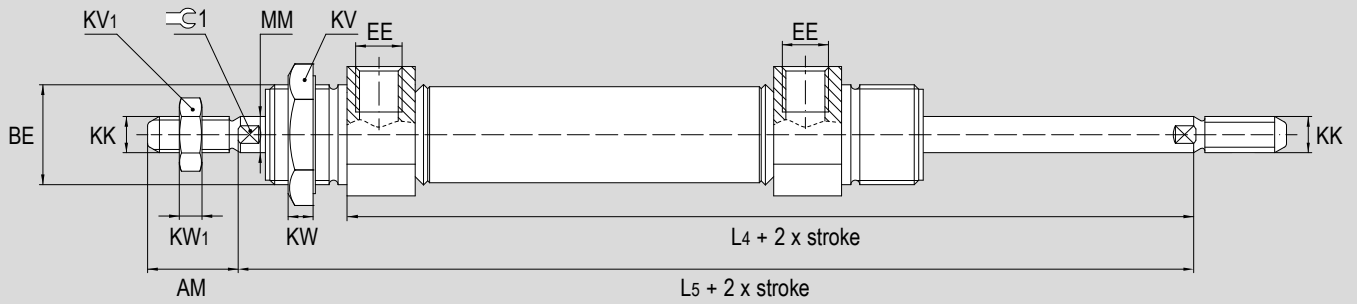

Type: ...B

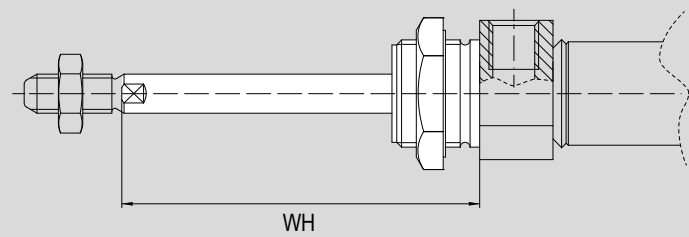

Ø mm	L ₄	L ₅	EE	BE	KK	KW	KW ₁	⊕ 1	KV ₁	KV	MM	AM	WH
16	80	102	M5	M16x1,5	M6x1	8	3,5	5	12	24	6	16	-
20	83	107	G1/8"	M22x1,5	M8x1,25	6	5	7	14	27	8	20	72
25	92	120	G1/8"	M22x1,5	M10x1,25	6	6	9	17	27	10	22	74

Slide unit U-shaped, UGLB..

	For cylinder Ø mm	Code	Item	Compliance
	12	*	UGLB12/...	-
	16	*	UGLB16/...	
	20	*	UGLB20/...	
	25	*	UGLB25/...	

* for code see page 1.70.3

Slide unit H-shaped, UGPB..

	For cylinder Ø mm	Code	Item	Compliance
	12	*	UGPB12/...	-
	16	*	UGPB16/...	
	20	*	UGPB20/...	
	25	*	UGPB25/...	

* for code see page 1.70.3

Slide unit H-shaped, UGPS..

	For cylinder Ø mm	Code	Item	Compliance
	12	*	UGPS12/...	-
	16	*	UGPS16/...	
	20	*	UGPS20/...	
	25	*	UGPS25/...	

* for code see page 1.70.3

Static piston rod brake* normally closed ABS..CRD



	For cylinder Ø mm	Code	Item	Compliance
	20	042022	ABS020CRD	-
	25	042023	ABS025CRD	

Static piston rod brake* normally open ABS..ARD

	For cylinder Ø mm	Code	Item	Compliance
	20	042032	ABS020ARD	-
	25	042033	ABS025ARD	

* option B required



Female clevis with clip FF..ISO

	For cylinder Ø mm	Code	Item	Compliance
	8-10	041001	FF04ISO/DIN	
	12-16	041002	FF06ISO/DIN	
	20	041003	FF08ISO/DIN	
	25	041004	FF10ISO	



22mm direct mounting solenoid valves A1E1..MD

	For cylinder Ø mm	Code	Item	Cylinder matching
	20 ÷ 25	034226	A1E130MD	MS MSM



Female clevis with pin and seeger FFP..ISO

	For cylinder Ø mm	Code	Item	Compliance
	8-10	-	FFP04ISO/DIN	
	12-16	-	FFP06ISO/DIN	
	20	041049	FFP08ISO/DIN	
	25	041051	FFP10ISO	

Female clevis (body only) FFN..ISO

	For cylinder Ø mm	Code	Item	Compliance
	8-10	041091	FFN04ISO/DIN	
	12-16	041011	FFN06ISO/DIN	
	20	041018	FFN08ISO/DIN	
	25	041014	FFN10ISO	

Bearing heads (DIN 648K) with female thread RF..SE

	For cylinder Ø mm	Code	Item	Compliance
	8-10	041551	RF5SE	
	12-16	041552	RF6SE	
	20	041553	RF8SE	
	25	041554	RF10SE	

Self-aligning articulated coupling GB..

	For cylinder Ø mm	Code	Item	Compliance
	8-10	041701	GB008	-
	12-16	041702	GB010	
	20	041703	GB020	
	25	041704	GB040	

Axial articulated coupling RBL..

	For cylinder Ø mm	Code	Item	Compliance
	12-16	041602	RBI6	-
	20	041603	RBI8	
	25	041604	RBI10	



Angular articulated coupling RBL..

	For cylinder Ø mm	Code	Item	Compliance
	12-16	041652	RBL6	-
	20	041653	RBL8	
	25	041654	RBL10	



Self-aligning coupling GC..

	For cylinder Ø mm	Code	Item	Compliance
	25	041722	GCM10x1,25	-

Rod nut D..



	For cylinder Ø mm	Code	Item	Compliance
	8-10	881397	D4x0,7	 5589
	12-16	041450	D6x1	
	20	041451	D8x1,25ZB	
	25	041452	D10x1,25ZB	

Rear clevis in steel with pin and seeger CF..+P

	For cylinder Ø mm	Code	Item	Compliance
	8-10	040048	CF08-10+P	 MP3
	12-16	040049	CF12-16+P	
	20-25	040050	CF20-25+P	



Kit composed by rear clevis, pin and two seeger.

High foot in steel P..

	For cylinder Ø mm	Code	Item	Compliance
	8-10	040021	P08-10	 MS3
	12-16	040022	P12-16	
	20-25	040023	P20-25	



Supplied individually.

Flange in steel F..

	For cylinder Ø mm	Code	Item	Compliance
	8-10	040001	F08-10	 MF8
	12-16	040002	F12-16	
	20-25	040003	F20-25	



Supplied individually.

ATEX magnetic reed switch T groove MK..

	For cylinder Ø mm	Code	Item	Compliance	Cylinder matching
	8 ÷ 25	071120	MK500A		MSM* MDM* MDMA*
		071108	MK502A		

*With bracket type AFM.. for magnetic reed switches T groove

Magnetic reed switch T groove ASV..

	For cylinder Ø mm	Code	Item	Cylinder matching	
	8 ÷ 25	070946		ASV1C525	MSM* MDM* MDMA*
		071863		ASV1C550	
		071864		ASV1C51K	
		071189		ASV1C5M8	
		073639		ASV4D225	
		070246		ASV4D2M8	
		074900		ASV7N225	
		070247		ASV7N2M8	
		070372		ASV7M2M8	
		072918		ASV1H525	

*With bracket type AFM.. for magnetic reed switches T groove

Bracket for magnetic reed switch T groove AFM..

	For cylinder Ø mm	Code	Item	Compliance
	8	072901	AFM8	-
	10	072902	AFM10	
	12	072903	AFM12	
	16	072904	AFM16	
	20	072905	AFM20	
	25	072906	AFM25	

CYLINDERS

ISO 15552



Find out our
key products



Solution for most applications



Easy and intuitive choice



Excellent value for money



Wide availability



Fast delivery



Features and certifications

Series of cylinders conforming to ISO 15552 standards in bores from Ø 32 to 320, double acting, magnetic. The cylinders of these series differ from each other for the heads, light or flat, and the barrel, with profile tube or round tube with tie-rods. Supplied as standard in compliance with Reach and RoHS directives, and SIL certified. On request, they can be also supplied according to the 2014/34/EU ATEX Directive. These features, combined with a modern and clean design, and the wide range of applications for which they are suitable place these cylinders among the core products of the company.



Type AMA Ø 32 ÷ 125 from page 1.5.20



Cylinders ISO 15552, available in bores from Ø 32 to 125, double acting magnetic with adjustable cushioning, with profile barrel and two different kind of grooves (T type on the port side, and "C" type on the opposite side), to apply magnetic reed switches directly, and interchange with most competitors. The design is modern and clean, the heads are light and characterized by powder-coating.

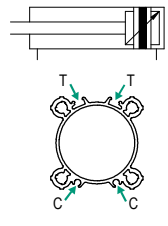

Type AMT Ø 32 ÷ 125 from page 1.5.20



Cylinders ISO 15552, available in bores from Ø 32 to 125, double acting magnetic with adjustable cushioning, made with round tube and tie-rods. The design is modern and clean, the heads are light and characterized by powder-coating.

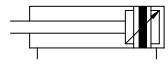

Type BMA Ø 32 ÷ 125 from page 1.5.50



Cylinders ISO 15552, available in bores from Ø 32 to 125, double acting magnetic with adjustable cushioning, with profile barrel and two different kind of grooves (T type on the port side, and "C" type on the opposite side), to apply magnetic reed switches directly, and interchange with most competitors. The design is modern and clean, the heads are flat.

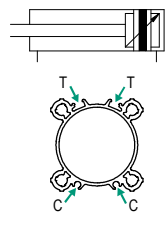

Type BMT Ø 32 ÷ 125 from page 1.5.50



Cylinders ISO 15552, available in bores from Ø 32 to 125, double acting magnetic with adjustable cushioning, made with round tube and tie-rods. The design is modern and clean, the heads are flat.

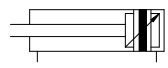

Type AMT Ø 160 ÷ 320 from page 1.5.70



Cylinders ISO 15552, available in bores from Ø 160 to 320, double acting magnetic with adjustable cushioning, made with round tube and tie-rods. The design is characterized by the heads light and powder-coated.

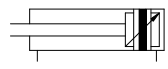

Options		
Description	Symbol	Suffix
Through rod		P
Stainless Steel AISI 304 rod		K
Stainless Steel AISI 316 rod		K316
Stainless Steel tie-rods (available only for AMT and BMT type)		K1
Stainless head nuts and rod nut (available only for AMT and BMT type up to Ø 200)		K2
Extended rod in hardened and chrome plated steel suitable for static piston rod brake (available up to Ø 125)		B
Extended rod in hardened and chrome plated steel suitable for dynamic piston rod brake (available up to Ø 100)		B1
FKM seals -20°C ÷ +150°C		V
FKM rod seal -20°C ÷ +80°C		V1
Rod seal scraper in special elastomer for applications in dirty and dusty environment (available up to Ø 200) -20°C ÷ +80°C		E8
Low temperature seals -40°C ÷ +80°C		BT
Tandem forward movement piston rods coupled together		TA1
Tandem forward movement piston rods independent		TA2
Tandem back to back		TA3
Tandem front to front		TA4
Extended rod (indicate the requested WH dimension in mm, E.g.: WH=100; for further information please contact the sales department)		WH=..
Without adjustable cushionings		D
Adjustable rear cushioning only		D1
Adjustable front cushioning only		D2
Special male thread (indicate the requested thread. E.g.: R-M 10x1.5; the dimension AM of the special thread will be the same as the standard; cylinder will be supplied without rod nut; for further information please contact the sales department)		R-M..
Female thread		F
With bellow for protection of the rod (in this case the dimension WH should be extended according the stroke of the cylinder; for further information please contact the sales department)		Z
NBR seals -20°C ÷ +80°C		H
NBR rod seal -20°C ÷ +80°C		H1
Brass rod scraper (only with H, H1, V, V1 or BT options; for further information please contact the sales department)		Y
Stainless Steel AISI 316L tube (available only for AMT and BMT type)		TX
Epoxy coating (RAL 7035)		EPX
ATEX versions on request (only with K or K316 options; for further information please contact the sales department)		/ATEX
Special versions on request		/S

The options, when this is possible, can be combined with each other. For options matching see from page 1.5.4; For code key see from page 1.5.6.

Options matching

Series	Bore	Model	Standard options matching										
			P	K	K316	K1	K2 (Ø32÷200)	B	B1 (Ø32÷100)	V	V1	E8 (Ø32÷200)	BT
AMA-BMA	Ø 32 ÷ 125	Standard	●	●	●	-	-	●	●	●	●	●	●
		Through rod (P)		●	●	-	-	●	●	●	●	●	●
		Stainless Steel rod (K)	●		-	-	-	-	-	●	●	●	●
		Rod brake (B)	●	-	-	-	-		-	●	-	-	●
		Female thread (F)	● ⁽⁷⁾	●	●	-	-	●	●	●	●	●	●
		Bellow (Z)	-	●	●	-	-	-	-	●	-	-	●
AMT-BMT	Ø 32 ÷ 125	Standard	●	●	●	●	●	●	●	●	●	●	●
		Through rod (P)		●	●	●	●	●	●	●	●	●	●
		Stainless Steel rod (K)	●		-	●	●	-	-	●	●	●	●
		Rod brake (B)	●	-	-	●	●		-	●	-	-	●
		Female thread (F)	● ⁽⁷⁾	●	●	●	●	●	●	●	●	●	●
		Bellow (Z)	-	●	●	●	●	-	-	●	-	-	●
AMT	Ø 160 ÷ 320	Standard	●	●	●	●	●	-	-	●	●	●	●
		Through rod (P)		●	●	●	●	-	-	●	●	●	●
		Stainless Steel rod (K)	●		-	●	●	-	-	●	●	●	●
		Female thread (F)	● ⁽⁷⁾	●	●	●	●	-	-	●	●	●	●
		Bellow (Z)	-	●	●	●	●	-	-	●	-	-	●

Key

● allowed matching; - not allowed matching

Options matching notes

- (1) Option **WH=.** require to indicate the desired dimension in mm, whereas for some combinations the option **WH=.** should be required or optional. For further information please contact the sales department. If you choose the female thread (option **F**), please indicate the dimension **WF=.** and then the actual desired dimension in mm
- (2) Option **R-M..** require to indicate the desired thread. For further information please contact the sales department.
- (3) Option **Y** require that the cylinder mount seals of options **H, H1, V, V1** or **BT**. Not allowed in combination with option **E8**.
- (4) In the **/ATEX** versions, is required to mount the stainless steel rod (options **K** or **K316**).
- (5) With the options **B** or **B1**, for dimensions S or S1 (WH) please see the table in page 1.5.22 (series AMA and AMT) or page 1.5.52 (series BMA and BMT).
- (6) In the models with bellow (option **Z**) should be necessary the extended rod option (**WH=.**) for some bores or strokes. Otherwise the **WH=.** option can be chosen according to the customer's needs. For further information please contact the sales department.
- (7) With through rod (option **P**) the option female thread (**F**) and the option special male thread (**R-M..**) are applied on both sides of the rod. While the option extended rod (**WH=.**) is applied only to one side of the rod.

Standard options matching

TA1	TA2	TA3	TA4	WH=.. ⁽¹⁾	D	D1	D2	R-M.. ⁽²⁾	F	Z	H	H1	Y ⁽³⁾	TX _(Ø32-200)	EPX	/ATEX ⁽⁴⁾
●	●	●	●	●	●	●	●	●	●	●	●	●	●	-	●	●
-	-	-	-	● ⁽⁷⁾	●	●	-	● ⁽⁷⁾	● ⁽⁷⁾	-	●	●	●	-	●	●
●	●	●	●	●	●	●	●	●	●	●	●	●	●	-	●	●
-	-	-	-	● ⁽⁵⁾	●	●	●	●	●	-	●	●	-	-	-	-
●	●	●	-	●	●	●	●	-		●	●	●	●	-	●	●
-	-	-	-	● ⁽⁶⁾	●	●	●	●	●		●	●	-	-	●	●
●	●	●	●	●	●	●	●	●	●	●	●	●	●	●	●	●
-	-	-	-	● ⁽⁷⁾	●	●	-	● ⁽⁷⁾	● ⁽⁷⁾	-	●	●	●	●	●	●
●	●	●	●	●	●	●	●	●	●	●	●	●	●	●	●	●
-	-	-	-	● ⁽⁵⁾	●	●	●	●	●	-	●	●	-	●	-	-
●	●	●	-	●	●	●	●	-		●	●	●	●	●	●	●
-	-	-	-	● ⁽⁶⁾	●	●	●	●	●		●	●	-	●	●	●
●	●	●	●	●	●	●	●	●	●	●	●	●	●	●	●	●
-	-	-	-	● ⁽⁷⁾	●	●	-	● ⁽⁷⁾	● ⁽⁷⁾	-	●	●	●	●	●	●
●	●	●	●	●	●	●	●	●	●	●	●	●	●	●	●	●
●	●	●	-	●	●	●	●	-		●	●	●	●	●	●	●
-	-	-	-	● ⁽⁶⁾	●	●	●	●	●		●	●	-	●	●	●

Code key

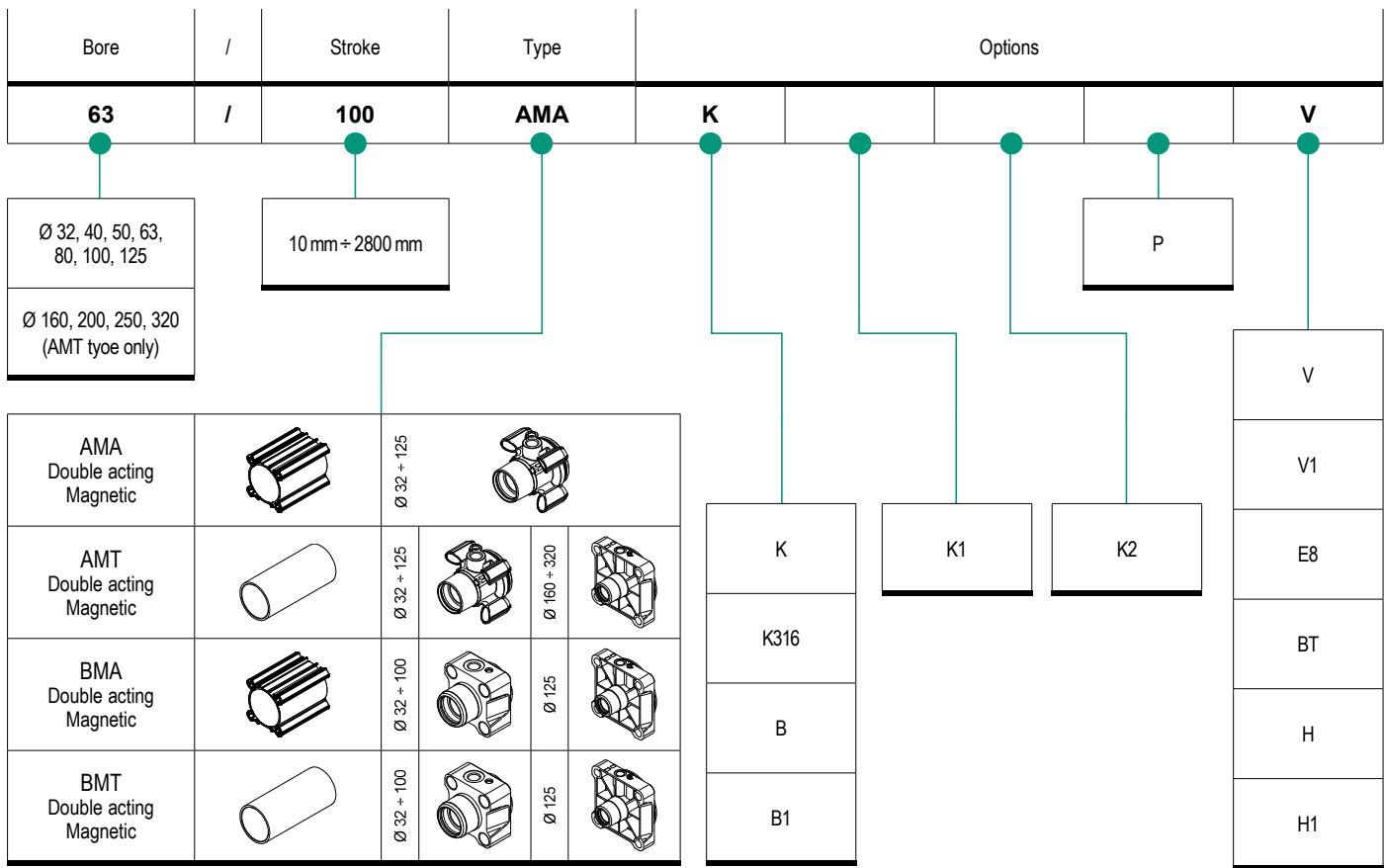

How to order

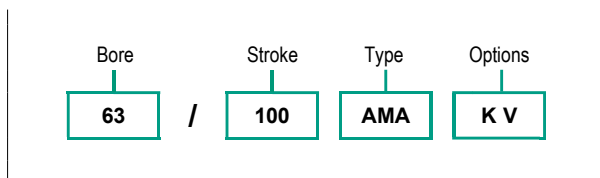

Notes

Options in the same grid are alternative to each others.

For further information on options and their matching, see page 1.5.3 and 1.5.4

For further information on the ATEX 2014/34/EU Directive, on classifications and protections, see from page III.1

Standard* seal kit

Number of components	Description
n. 1	Rod seal
n. 2	Cushioning seal
n. 2	Piston seal
n. 1	Linear rubber ring for piston (damper)
n. 2	Tube-head o-ring
n. 1	Piston guiding ring
n. 2	Adjustment screw o-ring
n. 1	Semipiston o-ring

Standard seal kit code key

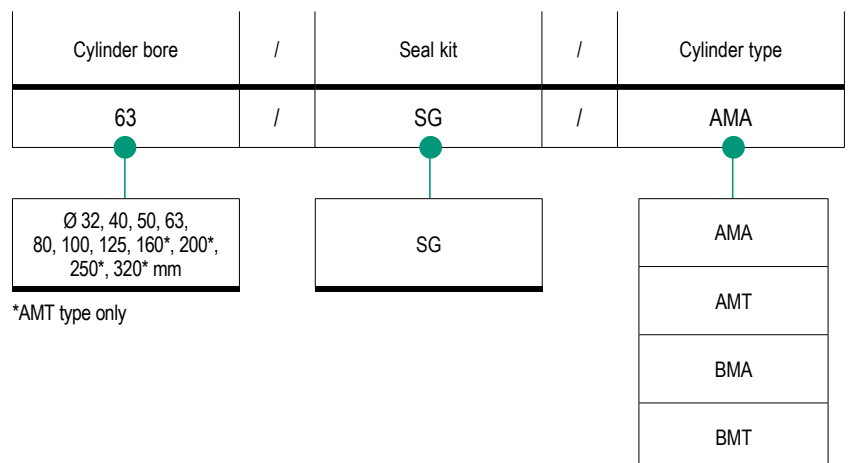

* For cylinders with options P, H, H1, V, V1 and BT, the kit include further components.

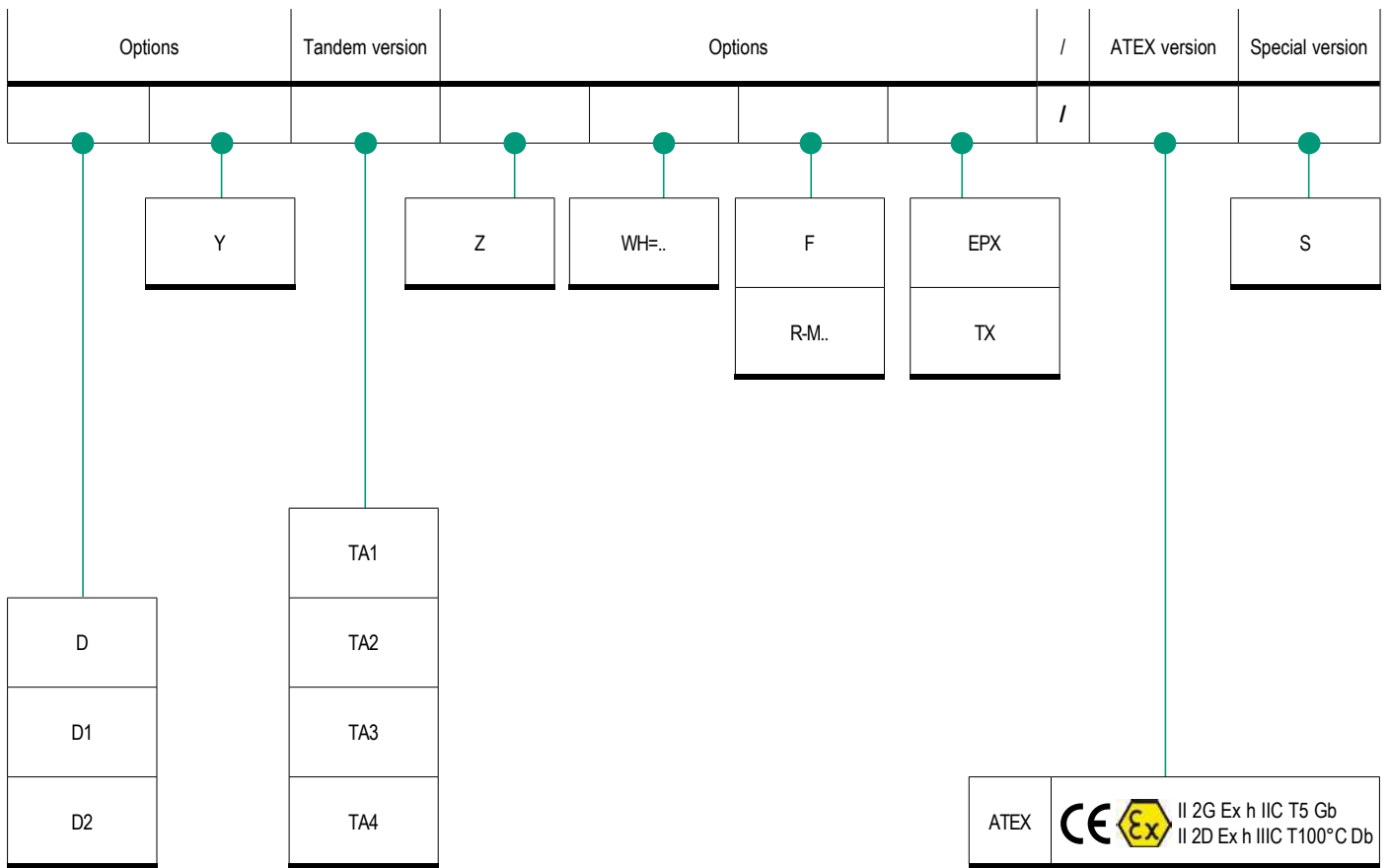

Standard materials

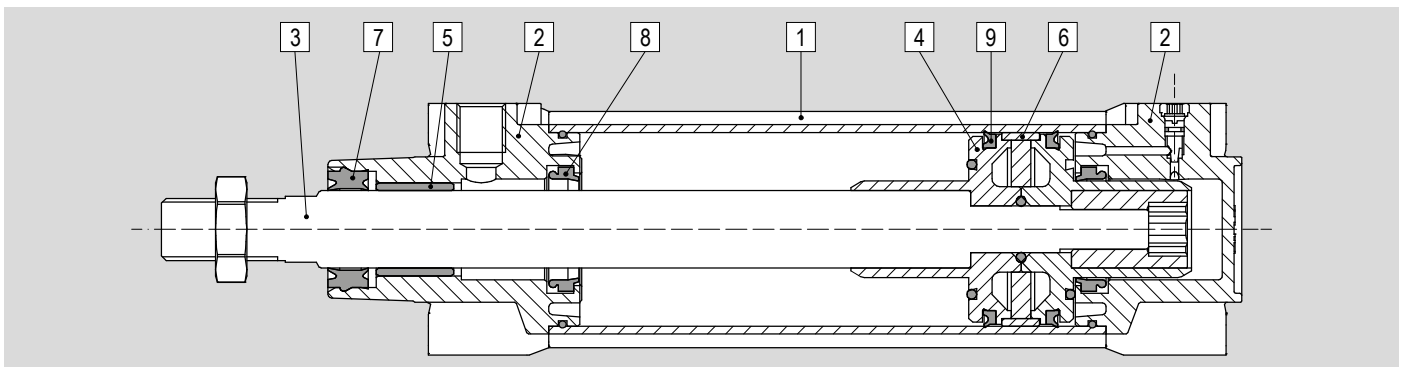

Position	Description	Material	
		Ø 32 ÷ 100	Ø 125 ÷ 320
1	Tube	Anodised aluminium	
2	Heads	Die cast painted aluminium (powder coating for AMA and AMT type, spray for BMA and BMT type)	
3	Rod	Chrome-plated C45 steel	
4	Piston	Die cast painted aluminium	
5	Bushing	Self-lubricating sintered bronze	
6	Guide ring	Acetalic resin (POM)	
7	Rod seals	Polyurethane (PU)	
8	Cushioning seals	Polyurethane (PU)	
9	Piston seals	Polyurethane (PU)	NBR
-	Tie-rods (for type AMT and BMT only)	Zinc-plated steel	
-	Other seals	NBR	

Accessories

1 - CYLINDERS

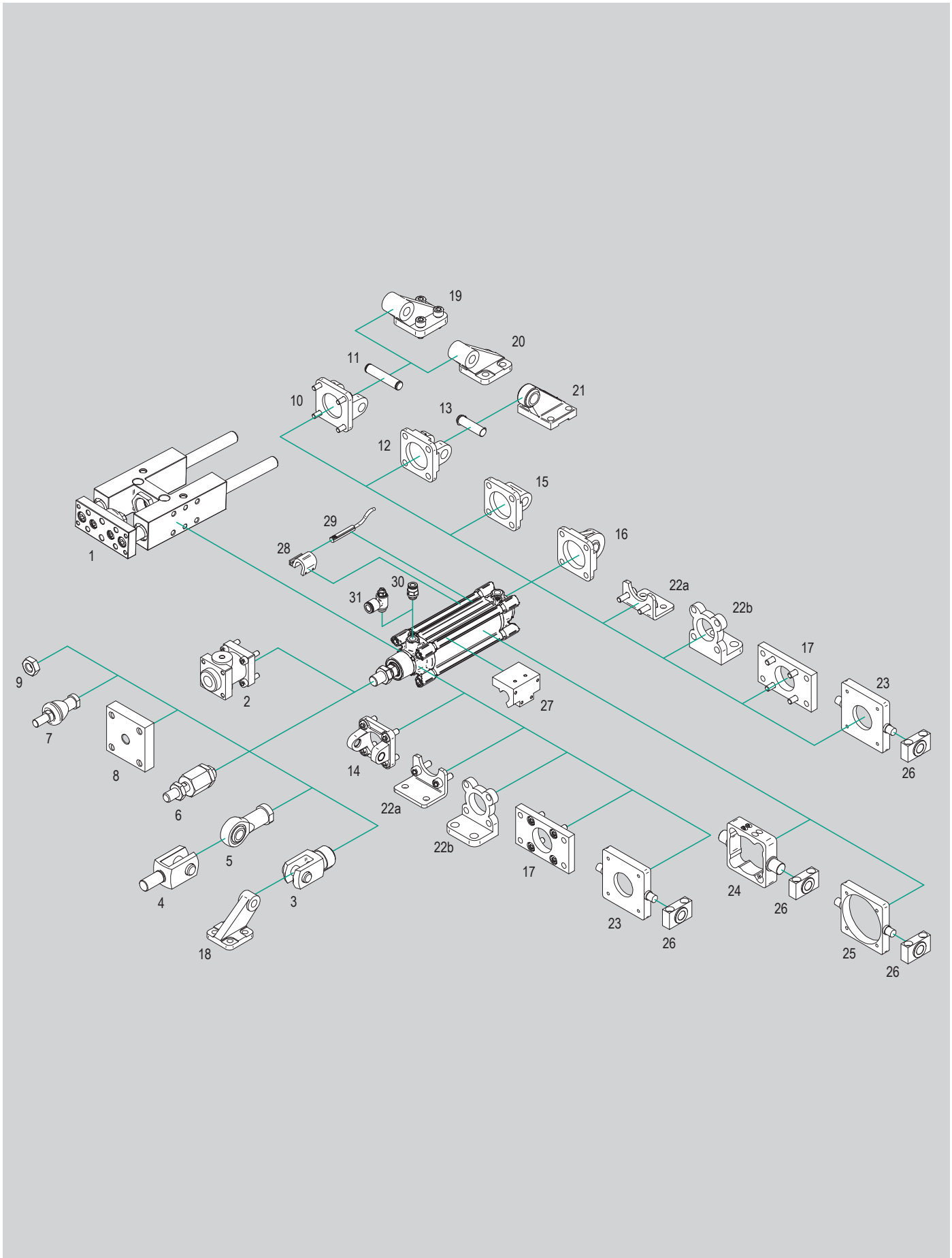

N.	Cylinder bore	Item	Description	Compliance	Matching				Code page	Data sheet page				
					AMA	BMA	AMT	BMT						
1	Ø 32 ÷ 100	UGLB	Slide unit U-shaped	-	●	●	●	●	1.5.90	1.70.1				
		UGPB UGPS	Slide unit H-shaped		●	●	●	●						
2	Ø 32 ÷ 125	ABS	Static rod brake	-	●	●	●	●	1.5.90	1.75.1				
	Ø 32 ÷ 100	ABK	Dynamic rod brake		●	●	●	●						
3	Ø 32 ÷ 100	FF..ISO	ISO female clevis with clip	ISO 8140	●	●	●	●	1.5.91	1.85.10				
	Ø 32 ÷ 320	FFP..ISO	ISO female clevis with pin and seeger		●	●	●	●						
	Ø 32 ÷ 125	FFN..ISO	ISO female clevis (body only)		●	●	●	●						
4	-	FEM..	Female clevis with male thread	-	●	●	●	●	1.85.11	1.88.1				
5	Ø 32 ÷ 320	RF..SE	Bearing head (DIN 648K) with female thread	ISO 8139	●	●	●	●	1.90.1					
6	Ø 32 ÷ 320	GB..	Bearing - Self-aligning articulated coupling	-	●	●	●	●	1.5.91	1.90.10				
7	Ø 32 ÷ 100	RBI..	Bearing - Axial articulated coupling		●	●	●	●		1.90.20				
		RBL..	Bearing - Angular articulated coupling		●	●	●	●		1.90.30				
8	Ø 32 ÷ 200	GC..	Self-aligning coupling			●	●	●		●	1.90.40			
9	Ø 32 ÷ 320	D..	Rod nut	UNI 5589	●	●	●	●	1.90.70					
10	Ø 32 ÷ 320	CF..ALIS	Rear clevis	ISO MP2	●	●	●	●	1.5.92	1.97.1				
		CF..AQIS								1.98.1				
11	Ø 32 ÷ 320	SEC..AQIS	Pin with seeger	ISO AA4	●	●	●	●	1.5.95	1.98.5				
12	Ø 32 ÷ 250	CFS..ALIS	Narrow rear clevis	ISO AB6	●	●	●	●	1.5.92	1.97.2				
	Ø 32 ÷ 125	CFS..AQIS								1.98.1				
13	Ø 32 ÷ 250	SEC..ARAQIS	Anti-rotating pin for narrow rear clevis	ISO AA6	●	●	●	●	1.5.95	1.98.5				
14	Ø 32 ÷ 200	CFA..	Front clevis	ISO MP7	●	●	●	●	1.5.94					
15	Ø 32 ÷ 320	CM..ALIS	Rear eye	ISO MP4	●	●	●	●	1.5.92	1.97.3				
		CM..AQIS								1.98.2				
16	Ø 32 ÷ 320	CMS..ALIS	Narrow rear eye with spherical bearing (DIN 648K)	ISO MP6	●	●	●	●	1.5.92	1.97.4				
	Ø 32 ÷ 125	CMS..AQIS								1.98.2				
17	Ø 32 ÷ 200	FLV..ALIS	Flange	ISO VDMA MF1-MF2	●	●	●	●	1.5.93	1.97.4				
	Ø 32 ÷ 320	FLV..AQIS								1.98.4				
18	Ø 32 ÷ 250	ASF..ALIS	Clevis hinge	ISO AB7	●	●	●	●	1.5.93	1.97.5				
19	Ø 32 ÷ 250	ASV..ALIS	Rear 90° hinge	CETOP RP 107P	●	●	●	●		1.98.3				
	Ø 32 ÷ 125	ASV..AQIS												
20	Ø 32 ÷ 200	AS..ALIS		ISO 6431	●	●	●	●	1.97.6					
21	Ø 32 ÷ 125	ASS..	Rear 90° hinge with spherical bearing (DIN 648K)	ISO CS7	●	●	●	●	1.98.3					
22a	Ø 32 ÷ 320	PB..AQIS	Low foot	ISO MS1	●	●	●	●	1.5.94	1.98.4				
22b	Ø 32 ÷ 200	P..ALIS	Foot	ISO MS3	●	●	●	●		1.97.6				
23	Ø 32 ÷ 200	CTA..	Center trunnion for heads	ISO MT5/MT6	●	●	●	●	1.98.7					
24	Ø 32 ÷ 125	CTS..	Center trunnion (profile barrel)	ISO MT4	●	●	-	-	1.5.93	1.98.6				
		CTN..	Non adjustable center trunnion (threaded)							-	-	●	●	1.98.7
25	Ø 32 ÷ 200	CT..	Adjustable center trunnion (tie-rods)		-	-	●	●	1.98.6					
26	Ø 32 ÷ 320	ST..	Support for center trunnion	ISO AT4	●	●	●	●	1.5.94	1.98.8				
27	Ø 32 ÷ 200	PSV..	Plate for valves	-	●	●	●	●	1.5.94	2.39.1				
28	Ø 32 ÷ 320	AS..	Bracket for T type magnetic reed switches	-	●	●	●	●	1.5.95	1.120.3				
			Bracket for hi-temp. magnetic reed switches							1.120.4				
29	Ø 32 ÷ 320	ASV..	Magnetic reed switch T groove	2014/34/EU	●	●	●	●	1.5.95	1.110.10				
		ASC..	Magnetic reed switch C groove							●	●	-	-	1.110.30
		MK..	ATEX magnetic reed switch T groove							●	●	●	●	1.113.1
Ø 32 ÷ 320	ASH..	Hi-temperatures magnetic reed switch		●	●	●	●	1.111.1						
30	Ø 32 ÷ 320	R..	Push-in fittings	-	●	●	●	●	4.2.1					
31	Ø 32 ÷ 320	V..C	Flow controls, for cylinders		●	●	●	●	4.94.1					

Key
 ● matching accessory; - not matching accessory

Main features

32 ÷ 125

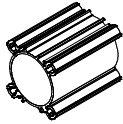
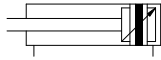

AMA

Bores Ø

Double acting
Magnetic
With cushioning

Tube profile

Type



32 ÷ 125

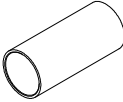
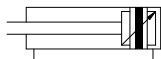

AMT

Bores Ø

Double acting
Magnetic
With cushioning

Tube profile

Type



Technical data

Bore Ø mm			32	40	50	63	80	100	125	
Fluid	Filtered compressed air with or without lubrication. Lubrication, if started, must be continued.									
Pressure range	1 ÷ 10 bar									
Temperature range	-20°C ÷ +80°C (standard / V1)			-20°C ÷ +150°C (V)			-40°C ÷ +80°C (BT)			
Strokes	10 ÷ 2800 mm									
Cushion length			20	22	25	25	35	35	35	
Port			1/8"	1/4"			3/8"		1/2"	
Rod thread			M10x1,25	M12x1,25	M16x1,5			M20x1,5		M27x2
Weight (g.)	Stroke zero		470	690	1.145	1.483	2.381	3.181	5.284	
	Additional 10 mm	AMA	21	29	44	47	69	80	119	
		AMT	21	29	44	47	69	80	119	

Standard strokes

Stroke mm	AMA Bore Ø mm						
	32	40	50	63	80	100	125
10	Key	Key	Key	Key	Key		
25	Key	Key	Key	Key	Key		
50	Key	Key	Key	Key	Key		
80	Key	Key	Key	Key	Key		
100	Key	Key	Key	Key	Key		
125	Key	Key	Key	Key	Key		
150	Key	Key	Key	Key	Key		
160	Key	Key	Key	Key	Key		
200	Key	Key	Key	Key	Key		
250	Key	Key	Key	Key	Key		
300	Key	Key	Key	Key	Key		
320	Key	Key	Key	Key	Key		
400	Key	Key	Key	Key	Key		
450	Key	Key	Key	Key	Key		
500	Key	Key	Key	Key	Key		

Stroke mm	AMT Bore Ø mm						
	32	40	50	63	80	100	125
10							
25							
50							
80							
100							
125							
150							
160							
200							
250							
300							
320							
400							
450							
500							

Key
 Standard stroke

Standard dimensions

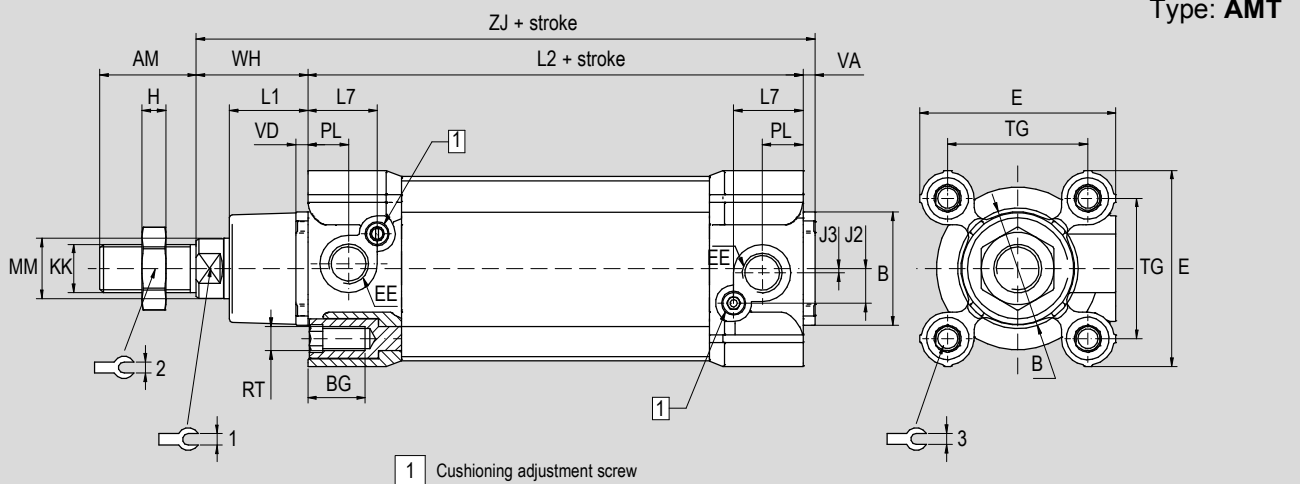
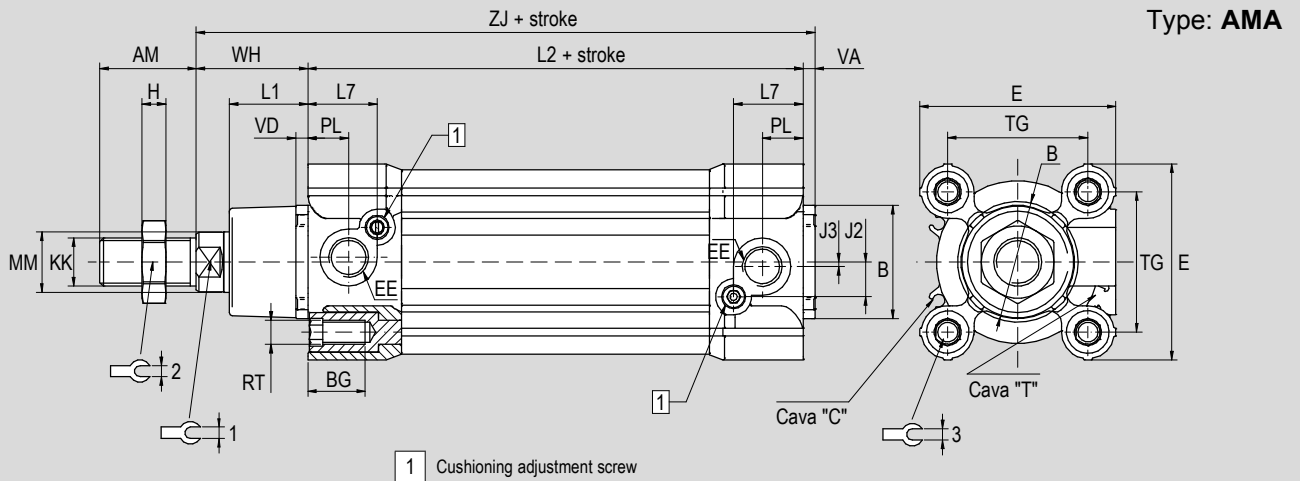

Ø (mm)	AM	ØB d11	BG	E	EE	J2	J3	ØKK	L1	L2	H
32	22	30	15	47	1/8"	7	3,5	M10x1,25	20	94	6
40	24	35	15	52	1/4"	7,5	4	M12x1,25	22	105	7
50	32	40	16	65	1/4"	11,5	1,5	M16x1,5	26	106	8
63	32	45	16	75	3/8"	13,5	1	M16x1,5	25	121	8
80	40	45	17	95	3/8"	13	1	M20x1,5	32	128	9
100	40	55	17	115	1/2"	15	6	M20x1,5	38	138	9
125	54	60	21	140	1/2"	17	8	M27x2	40	160	12

Ø (mm)	L7	ØMM f7	PL	RT	TG	VA	VD	WH	ZJ	1	2	3
32	19,4	12	8,5	M6	32,5	4	4	26	124	10	17	6
40	23	16	10	M6	38	4	4	30	139	13	19	6
50	23	20	13,5	M8	46,5	4	4	37	147	17	24	8
63	23	20	15	M8	56,5	4	4	37	162	17	24	8
80	30	25	21	M10	72	4	4	46	178	22	30	10
100	30,5	25	24	M10	89	4	4	51	193	22	30	10
125	27,5	32	23	M12	110	5	5	65	230	27	41	12

Dimensions with options

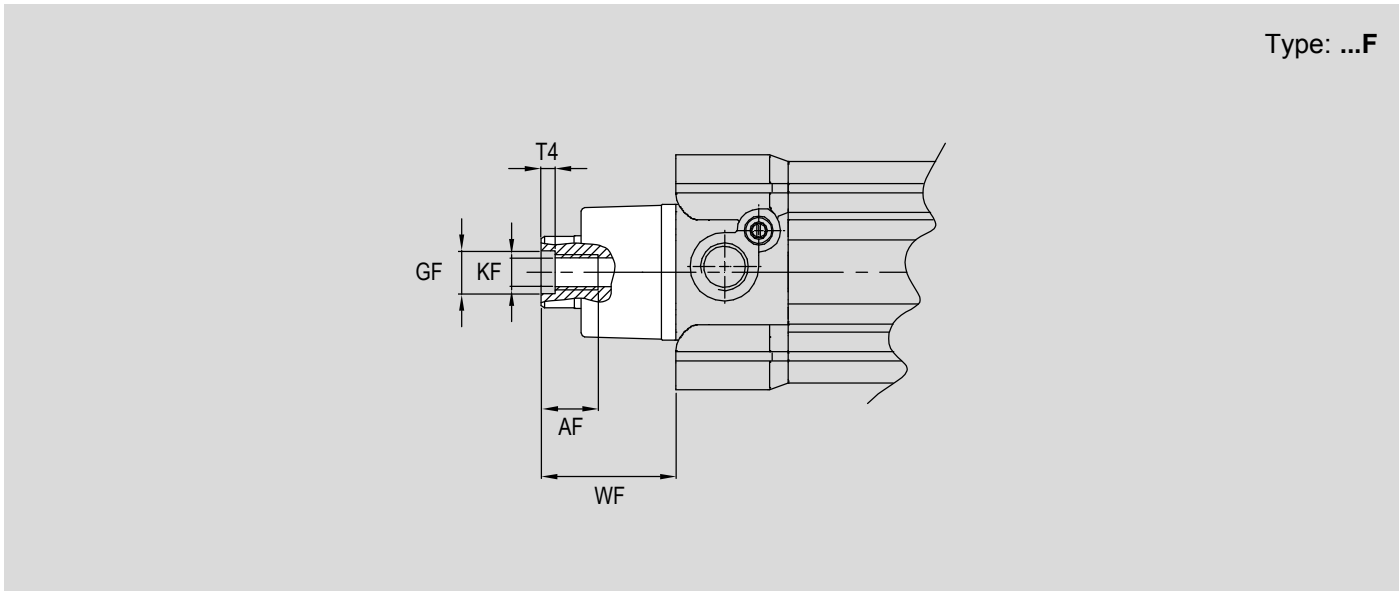
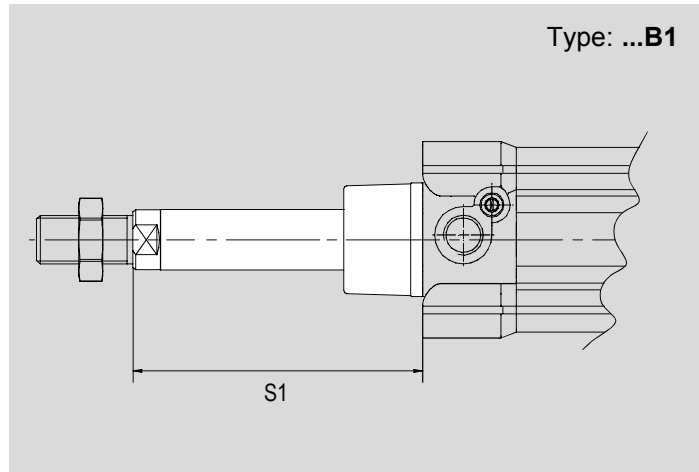
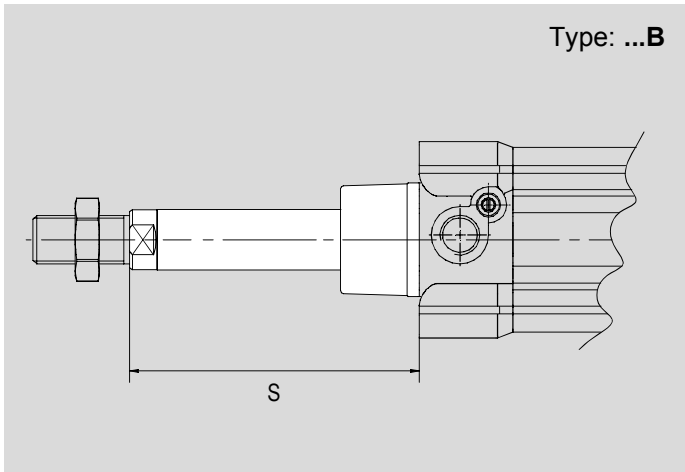
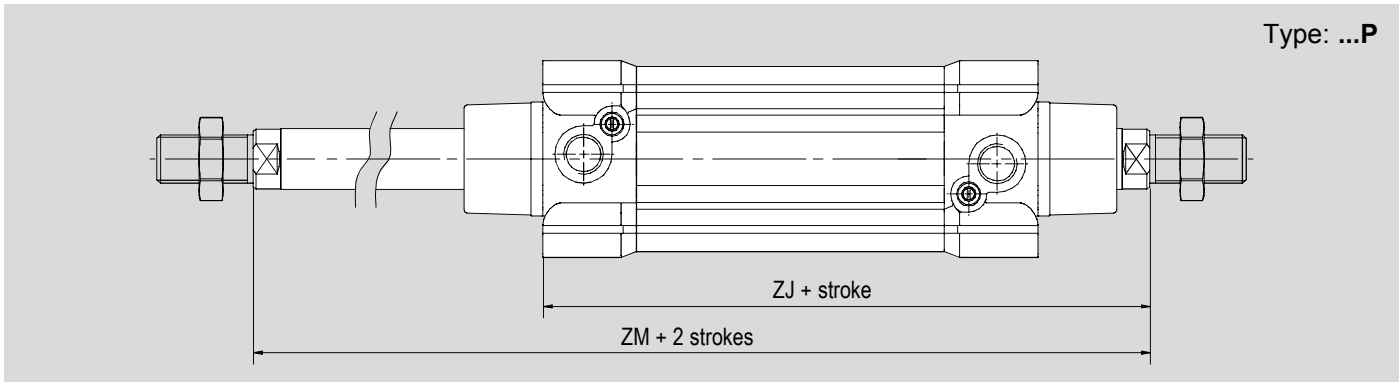

∅ mm	AF	GF	KF	T4	WF	S	S1	ZJ	ZM
32	12	8	M6	2,6	26	74	99	120	146
40	12	10	M8	3,3	30	85	106	135	165
50	16	12	M10	4,7	37	107	127	143	180
63	16	12	M10	4,7	37	107	129	158	195
80	20	14	M12	6,1	46	136	156	174	220
100	20	14	M12	6,1	51	143	181	189	240
125	32	18	M16	8	65	187	-	225	290

Dimensions tandem versions

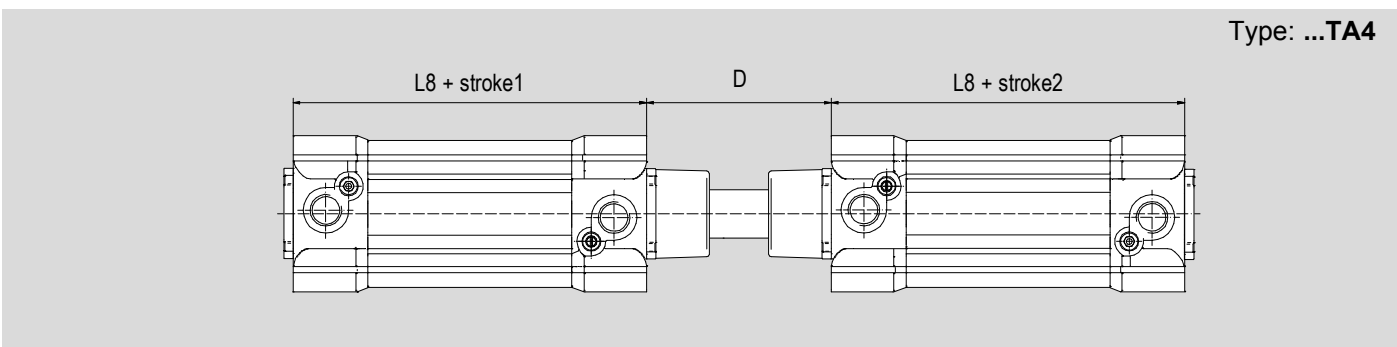
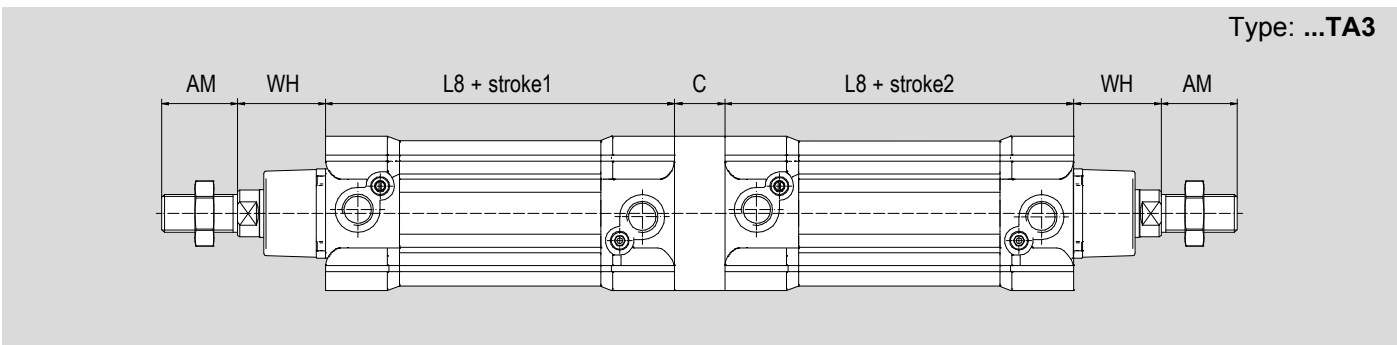
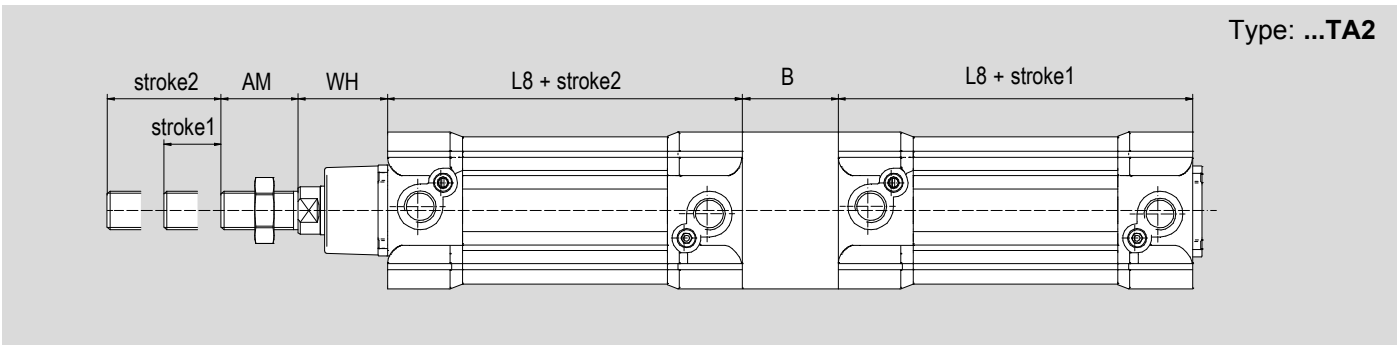
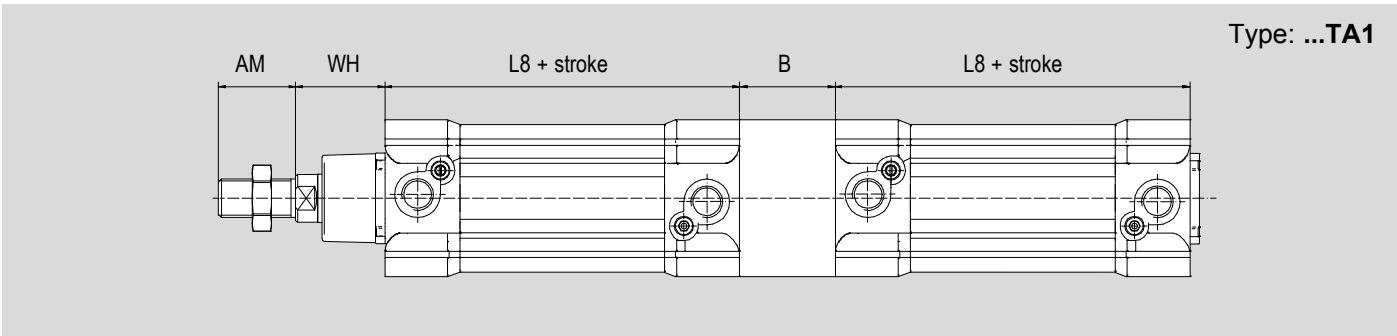

∅ mm	AM	B	C	D	L8	WH
32	22	40	12	48	94	26
40	24	44	12	54	105	30
50	32	52	16	69	106	37
63	32	50	16	69	121	37
80	40	64	20	86	128	46
100	40	76	20	91	138	51
125	54	80	35	120	160	65

Main features

32 ÷ 125

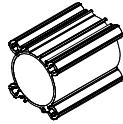
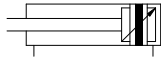

BMA

Bores Ø

Double acting
Magnetic
With cushioning

Tube profile

Type



32 ÷ 125

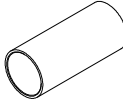
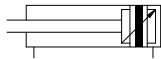

BMT

Bores Ø

Double acting
Magnetic
With cushioning

Tube profile

Type



Technical data

Bore Ø mm	32	40	50	63	80	100	125		
Fluid	Filtered compressed air with or without lubrication. Lubrication, if started, must be continued.								
Pressure range	1 ÷ 10 bar								
Temperature range	-20°C ÷ +80°C (standard / V1)		-20°C ÷ +150°C (V)		-40°C ÷ +80°C (BT)				
Strokes	10 ÷ 2800 mm								
Cushion length	20	22	25	25	35	35	35		
Port	1/8"	1/4"		3/8"		1/2"			
Rod thread	M10x1,25	M12x1,25	M16x1,5		M20x1,5		M27x2		
Weight (g.)	Stroke zero	470	690	1.145	1.483	2.381	3.181	5.284	
	Additional 10 mm	AMA	21	29	44	47	69	80	119
		AMT	21	29	44	47	69	80	119

Standard strokes

Stroke mm	BMA Bore Ø mm						
	32	40	50	63	80	100	125
10							
25							
50							
80							
100							
125							
150							
160							
200							
250							
300							
320							
400							
450							
500							

Stroke mm	BMT Bore Ø mm						
	32	40	50	63	80	100	125
10							
25							
50							
80							
100							
125							
150							
160							
200							
250							
300							
320							
400							
450							
500							

Key
 Standard stroke

Standard dimensions

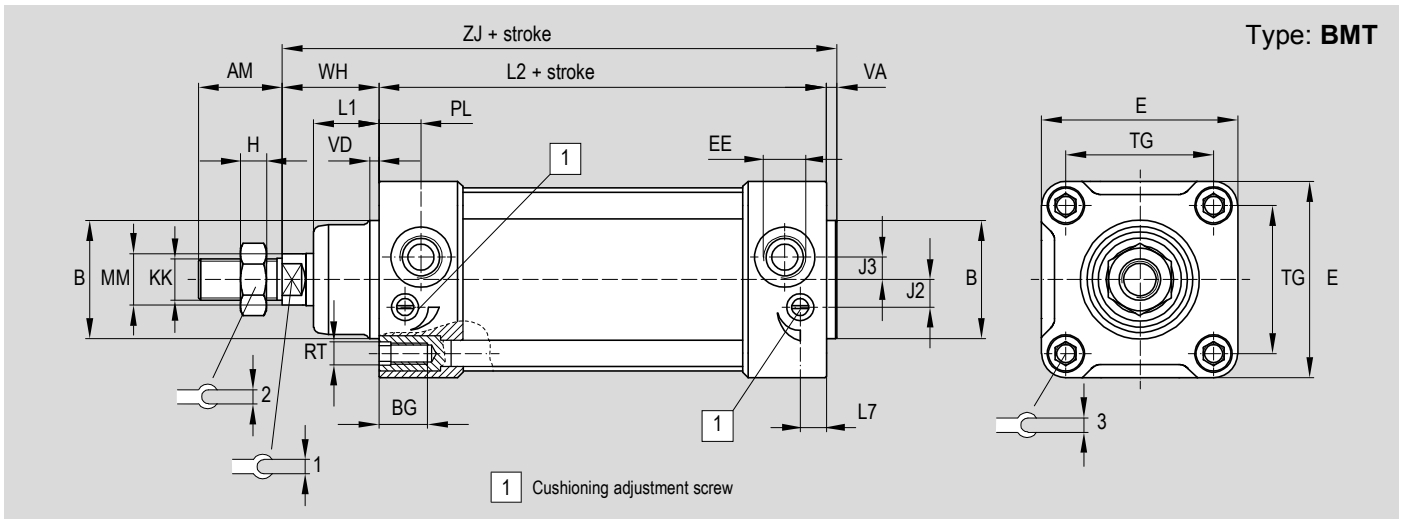
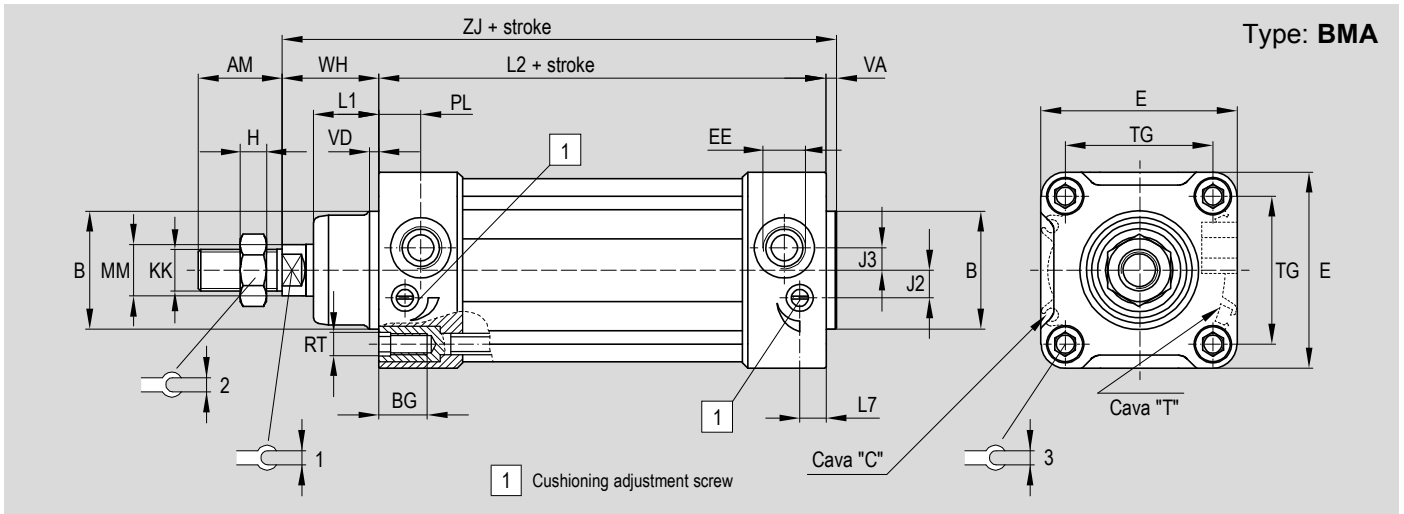

Ø (mm)	AM	ØB d11	BG	E	EE	J2	J3	ØKK	L1	L2	H
32	22	30	15	47	1/8"	5,75	5,25	M10x1,25	20	94	6
40	24	35	15	52	1/4"	8	6	M12x1,25	22	105	7
50	32	40	16	65	1/4"	10,5	6	M16x1,5	26	106	8
63	32	45	16	75	3/8"	10,5	8,5	M16x1,5	25	121	8
80	40	45	17	95	3/8"	14	9,5	M20x1,5	32	128	9
100	40	55	17	115	1/2"	15	10	M20x1,5	38	138	9
125	54	60	21	140	1/2"	20	10	M27x2	40	160	12

Ø (mm)	L7	ØMM f7	PL	RT	TG	VA	VD	WH	ZJ	1	2	3
32	18	12	11	M6	32,5	4	4	26	124	10	17	6
40	20	16	14	M6	38	4	4	30	139	13	19	6
50	20	20	15	M8	46,5	4	4	37	147	17	24	8
63	10	20	16	M8	56,5	4	4	37	162	17	24	8
80	13,5	25	20,5	M10	72	4	4	46	178	22	30	10
100	13	25	20	M10	89	4	4	51	193	22	30	10
125	30	32	25	M12	110	5	5	65	230	27	41	12

Dimensions with options

1 - CYLINDERS

Type: ...P

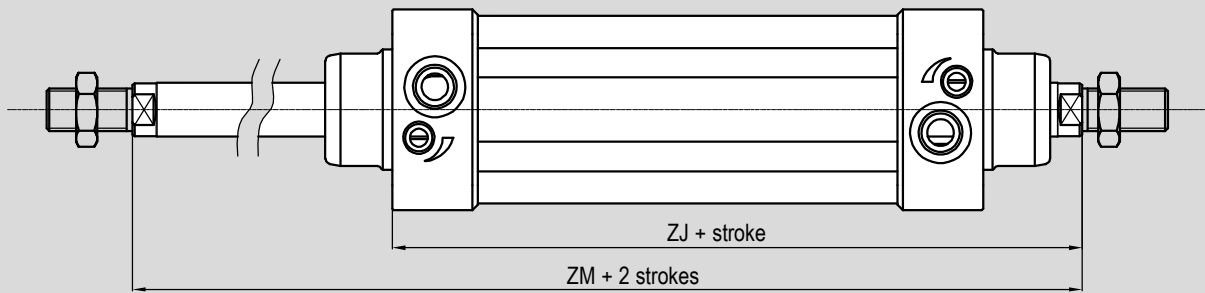

Type: ...B

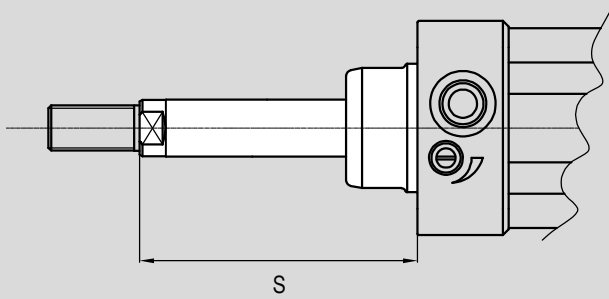

Type: ...B1

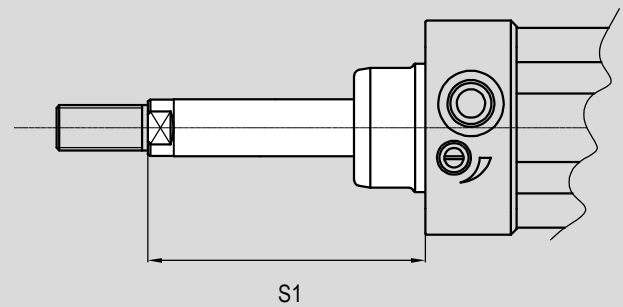

Type: ...F

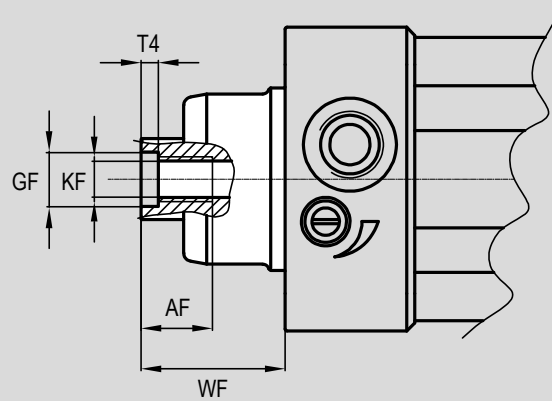

\varnothing mm	AF	GF	KF	T4	WF	S	S1	ZJ	ZM
32	12	8	M6	2,6	26	74	99	120	146
40	12	10	M8	3,3	30	85	106	135	165
50	16	12	M10	4,7	37	107	127	143	180
63	16	12	M10	4,7	37	107	129	158	195
80	20	14	M12	6,1	46	136	156	174	220
100	20	14	M12	6,1	51	143	181	189	240
125	32	18	M16	8	65	187	-	225	290

Dimensions tandem versions

Type: ...TA1

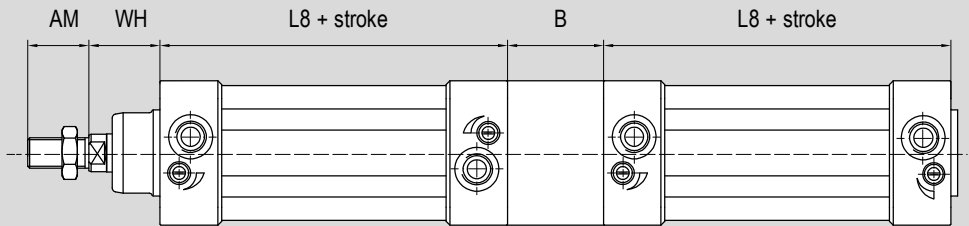

Type: ...TA2

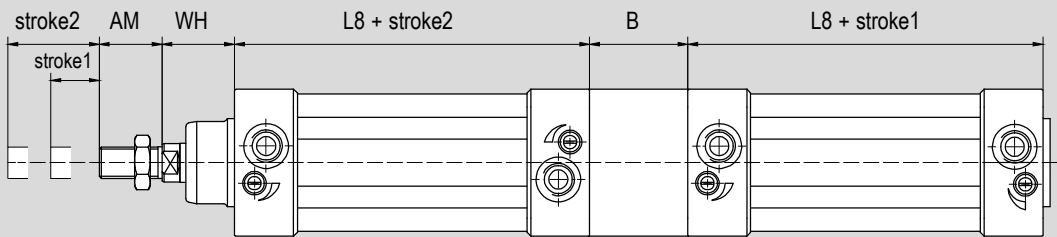

Type: ...TA3

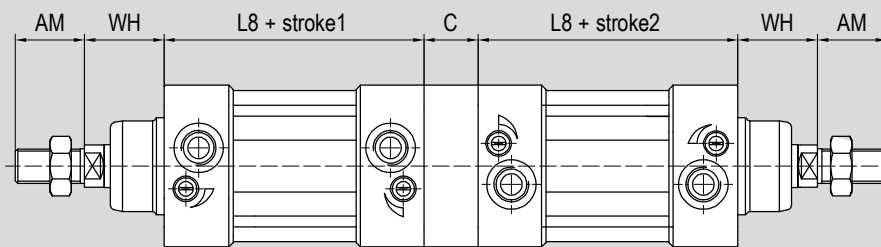

Type: ...TA4

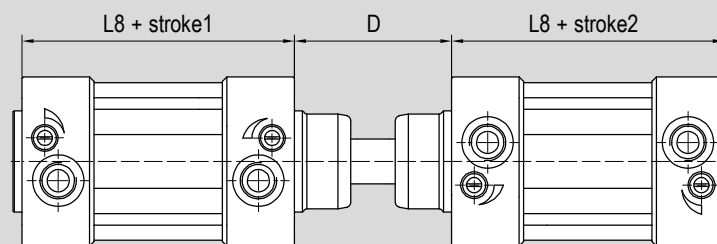

Ø mm	AM	B	C	D	L8	WH
32	22	40	12	48	94	26
40	24	44	12	54	105	30
50	32	52	16	69	106	37
63	32	50	16	69	121	37
80	40	64	20	86	128	46
100	40	76	20	91	138	51
125	54	80	35	120	160	65

Main features

160 ÷ 320

Bores Ø

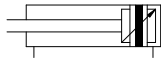

Double acting
Magnetic
With cushioning

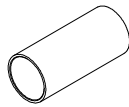

Tube profile

AMT

Type



Technical data

Bore Ø mm	160	200	250	320	
Fluid	Filtered compressed air with or without lubrication. Lubrication, if started, must be continued.				
Pressure range	1 ÷ 10 bar				
Temperature range	-20°C ÷ +80°C (standard / V1)	-20°C ÷ +150°C (V)	-40°C ÷ +80°C (BT)		
Strokes	10 ÷ 2800 mm				
Cushion length	46	47	40	40	
Port	3/4"		1"		
Rod thread	M36x2		M42x2	M48x2	
Weight (g.)	Stroke zero	11.507	14.532	26.811	47.996
	Additional 10 mm	234	250	384	597

Standard strokes

Stroke mm	AMT Bore Ø mm			
	160	200	250	320
10				
25				
50				
80				
100				
125				
150				
160				
200				
250				
300				
320				
400				
450				
500				

Key
 Standard stroke

Standard dimensions

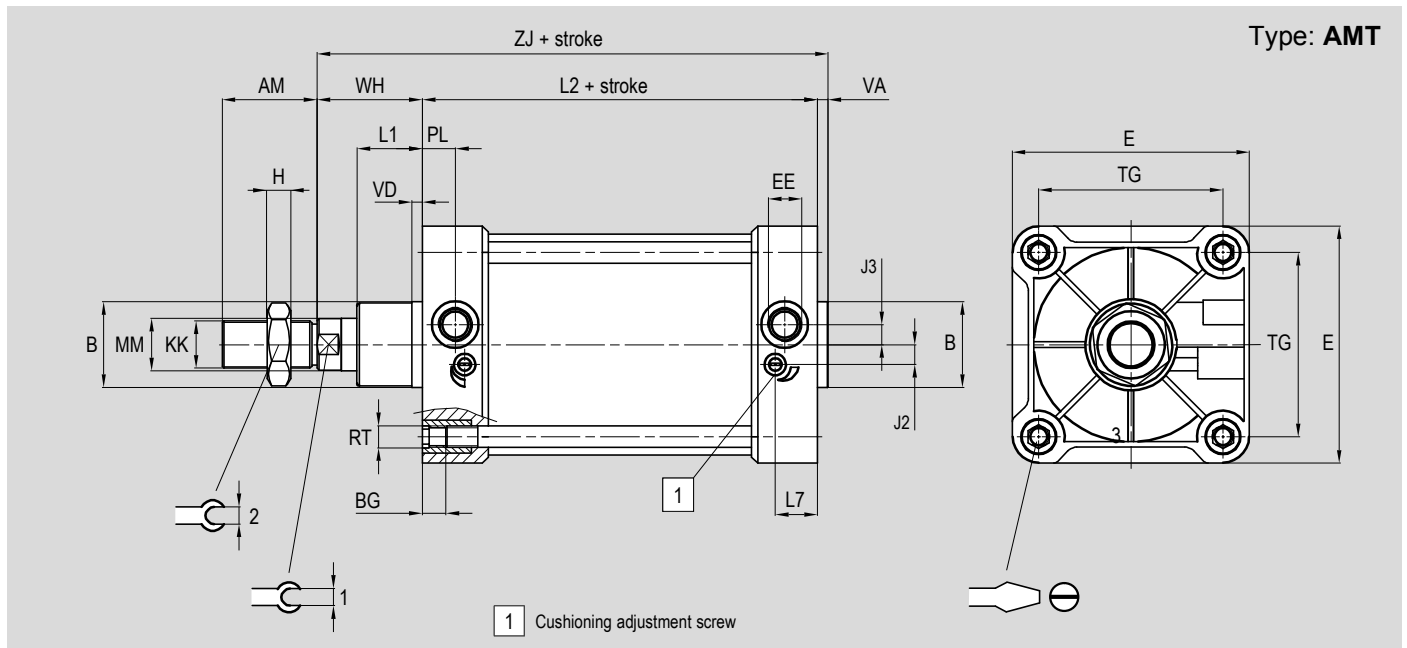

1 - CYLINDERS

∅ (mm)	AM	∅B d11	BG	E	EE	J2	J3	∅KK	L1	L2	H
160	72	65	24	180	G 3/4	15	15	M36x2	50	180	14
200	72	75	24	220	G 3/4	15	15	M36x2	65	180	14
250	84	90	25	270	G 1	25	25	M42x2	75	200	20
320	96	110	30	350	G 1	35	35	M48x2	90	220	17

∅ (mm)	L7	∅MM f7	PL	RT	TG	VA	VD	WH	ZJ			
160	32	40	25	M16	140	6	8	80	266	36	55	25x3,7
200	34	40	25	M16	175	6	25	95	281	36	55	25x3,7
250	40	50	30	M20	220	8	25	105	313	46	65	32x5,5
320	45	63	30	M24	270	10	25	120	350	55	75	36x5,5

Dimensions with options

1 - CYLINDERS

Type: ...P

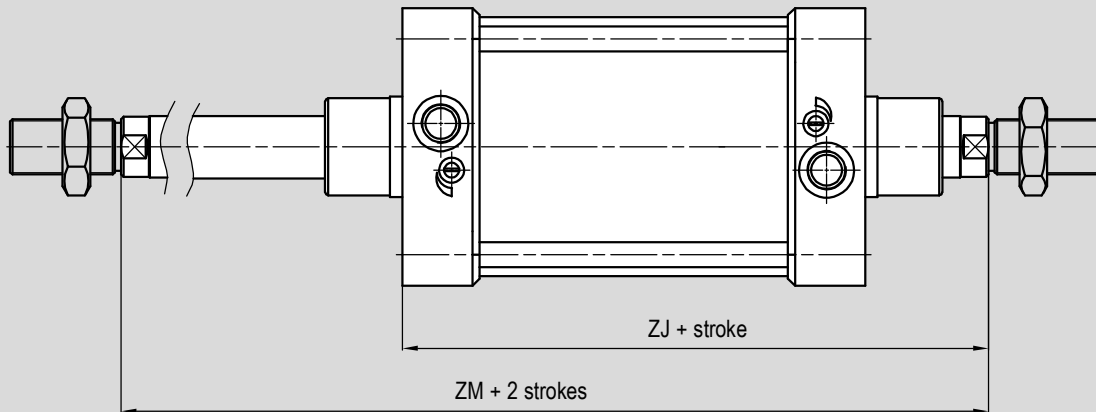

Type: ...F

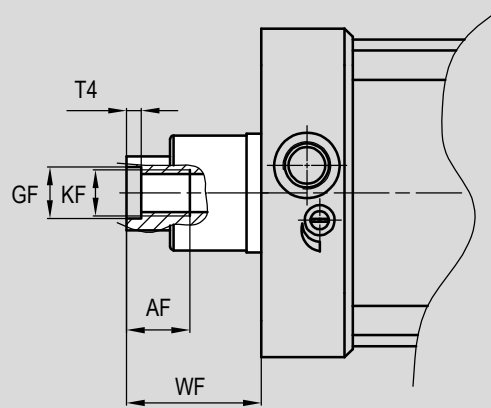

Ø mm	AF	KF	T4	WF	GF	ZJ	ZM
160	36	M20	10	80	22	260	340
200	36	M20	10	95	22	275	370
250	40	M24	12	105	26	305	410
320	50	M30	15	120	32	340	460

Dimensions tandem versions

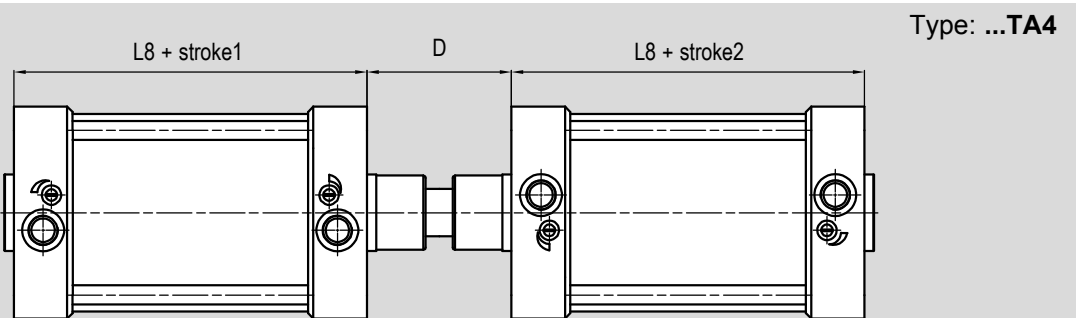
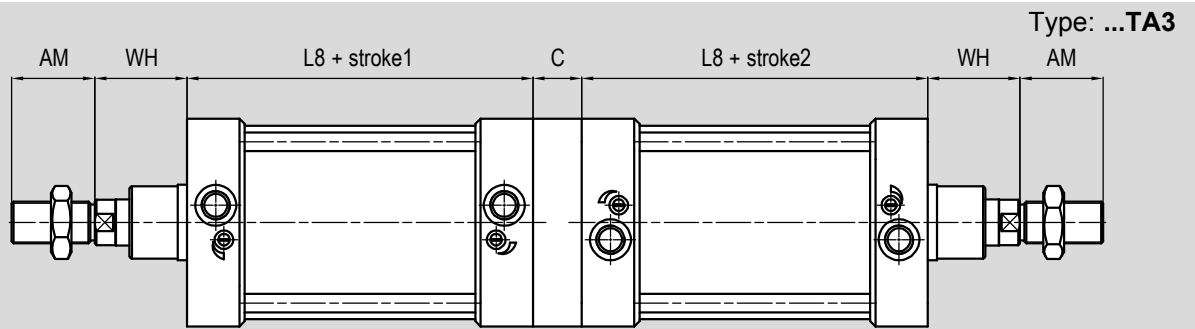
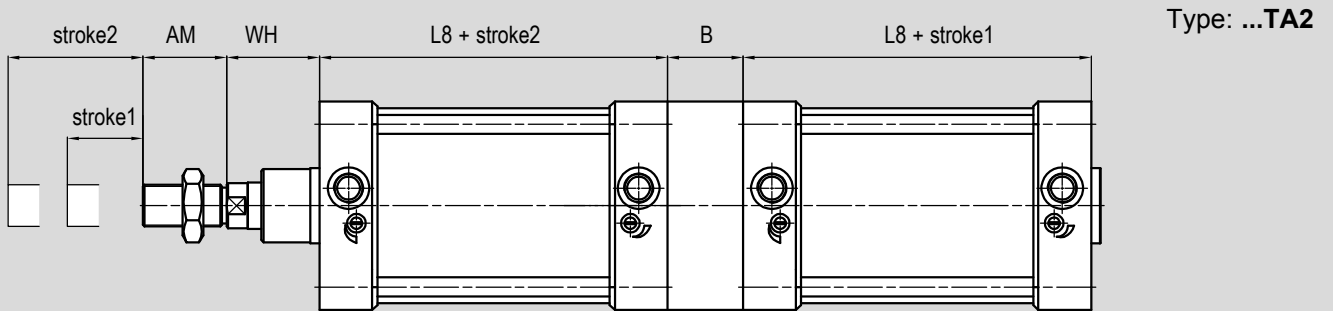
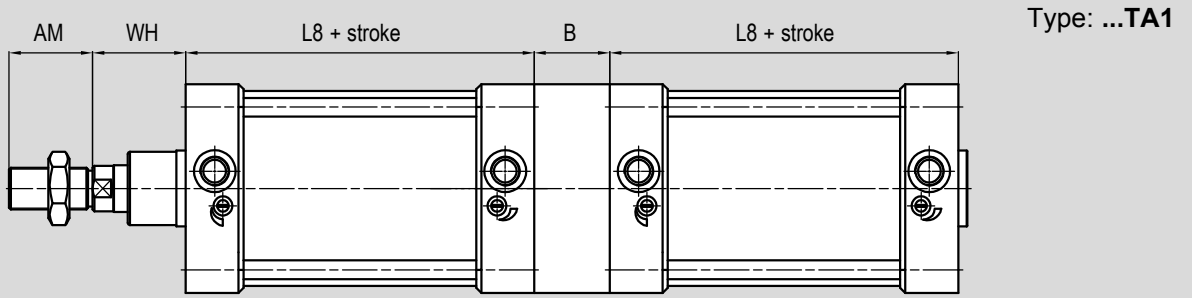

Ø mm	AM	B	C	D	L8	WH
160	72	100	50	152	180	80
200	72	130	50	167	180	95
250	84	150	60	180	200	105
320	96	180	70	200	220	120

Slide unit U-shaped, UGLB..

	For cylinder Ø mm	Code	Item	Compliance
	32	*	UGLB32/...	-
	40	*	UGLB40/...	
	50	*	UGLB50/...	
	63	*	UGLB63/...	
	80	*	UGLB80/...	
	100	*	UGLB100/...	

* for code see page 1.70.3

Slide unit H-shaped, UGPB..

	For cylinder Ø mm	Code	Item	Compliance
	32	*	UGPB32/...	-
	40	*	UGPB40/...	
	50	*	UGPB50/...	
	63	*	UGPB63/...	
	80	*	UGPB80/...	
	100	*	UGPB100/...	

* for code see page 1.70.3

Slide unit H-shaped, UGPS..

	For cylinder Ø mm	Code	Item	Compliance
	32	*	UGPS32/...	-
	40	*	UGPS40/...	
	50	*	UGPS50/...	
	63	*	UGPS63/...	
	80	*	UGPS80/...	
	100	*	UGPS100/...	

* for code see page 1.70.3

Static rod brake* normally closed ABS..CRD

	For cylinder Ø mm	Code	Item	Compliance
	32	042001	ABS032CRD	-
	40	042002	ABS040CRD	
	50	042003	ABS050CRD	
	63	042004	ABS063CRD	
	80	042005	ABS080CRD	
	100	042006	ABS100CRD	
	125	042007	ABS125CRD	

* option B required

Static rod brake* normally open ABS..ARD

	For cylinder Ø mm	Code	Item	Compliance
	32	042011	ABS032ARD	-
	40	042012	ABS040ARD	
	50	042013	ABS050ARD	
	63	042014	ABS063ARD	
	80	042015	ABS080ARD	
	100	042016	ABS100ARD	
	125	042017	ABS125ARD	



* option B required

Dynamic rod brake* normally closed ABK..



	For cylinder Ø mm	Code	Item	Compliance
	32	042035	ABK032	-
	40	042036	ABK040	
	50	042037	ABK050	
	63	042038	ABK063	
	80	042039	ABK080	
	100	042040	ABK100	

* option B1 required



Female clevis with clip FF..ISO

	For cylinder Ø mm	Code	Item	Compliance
	32	041004	FF10ISO	
	40	041005	FF12ISO	
	50-63	041006	FF16ISO	
	80-100	041007	FF20ISO	

Female clevis with pin and seeger FFP..ISO

	For cylinder Ø mm	Code	Item	Compliance
	32	041051	FFP10ISO	
	40	041040	FFP12ISO	
	50-63	041013	FFP16ISO	
	80-100	041017	FFP20ISO	
	125	041009	FFP27ISO	
	160-200	041010	FFP36ISO	
	250	041068	FFP42ISO	
320	041069	FFP48ISO		

Female clevis (body only) FFN..ISO

	For cylinder Ø mm	Code	Item	Compliance
	32	041014	FFN10ISO	 8140
	40	041016	FFN12ISO	
	50-63	041012	FFN16ISO	
	80-100	041015	FFN20ISO	
	125	*	FFN27ISO	
	160-200	*	FFN36ISO	
	250	*	FFN42ISO	
320	*	FFN48ISO		



* for code please contact the sales department

Female clevis with male thread FEM..

	For cylinder Ø mm	Code	Item	Compliance
	*	041061	FEM10	-
	*	041062	FEM12	
	*	041063	FEM16	
	*	041064	FEM20	
	*	041065	FEM27	

* for matching with bearing heads see page 1.88.1 and page 1.90.1

Bearing heads (DIN 648K) with female thread RF..SE

	For cylinder Ø mm	Code	Item	Compliance
	32	041554	RF10SE	 8139
	40	041555	RF12SE	
	50-63	041557	RF16SE	
	80-100	041559	RF20SE	
	125	041562	RF30SE	
	160-200	041563	RF35SE	
	250	041571	RF40SE	
320	041572	RF50SE		

Self-aligning articulated coupling GB..

	For cylinder Ø mm	Code	Item	Compliance
	32	041704	GB040	-
	40	041706	GB060	
	50-63	041708	GB100	
	80-100	041709	GB120	
	125	041711	GB130	
	160-200	041712	GB160-200	
	250	041713	GB250	
	320	041714	GB320	

Axial articulated coupling RBL..

	For cylinder Ø mm	Code	Item	Compliance
	32	041604	RBL10	-
	40	041605	RBL12	
	50-63	041607	RBL16	
	80-100	041609	RBL20	



Angular articulated coupling RBL..

	For cylinder Ø mm	Code	Item	Compliance
	32	041654	RBL10	-
	40	041655	RBL12	
	50-63	041657	RBL16	
	80-100	041659	RBL20	

Self-aligning coupling GC..

	For cylinder Ø mm	Code	Item	Compliance
	32	041722	GCM10x1,25	-
	40	041723	GCM12x1,25	
	50-63	041724	GCM16x1,5	
	80-100	041725	GCM20x1,5	
	125	041726	GCM27x2	
160-200	041727	GCM36x2		

Rod nut D..

	For cylinder Ø mm	Code	Item	Compliance
	32	041452	D10x1,25	 5589  936
	40	041454	D12x1,25	
	50-63	041455	D16x1,5	
	80-100	041456	D20x1,5	
	125	041458	D27x2	
	160-200	041459	D36x2	
	250	041449	D42x2	
	320	041477	D48x2	

Rear clevis in aluminium with screws and pin CF..ALIS+VP

For cylinder Ø mm	Code	Item	Compliance
32	042050	CF032ALIS+VP	 MP2
40	042051	CF040ALIS+VP	
50	042052	CF050ALIS+VP	
63	042053	CF063ALIS+VP	
80	042054	CF080ALIS+VP	
100	042055	CF100ALIS+VP	
125	042056	CF125ALIS+VP	
160	042057	CF160ALIS+VP	
200	042058	CF200ALIS+VP	
250	042059	CF250ALIS+VP	
320	042060	CF320ALIS+VP	

Rear clevis in aluminium* with screws CF..ALIS+V

For cylinder Ø mm	Code	Item	Compliance
32	040441	CF032ALIS+V	 MP2
40	040442	CF040ALIS+V	
50	040443	CF050ALIS+V	
63	040444	CF063ALIS+V	
80	040445	CF080ALIS+V	
100	040446	CF100ALIS+V	
125	040447	CF125ALIS+V	
160	040448	CF160ALIS+V	
200	040449	CF200ALIS+V	
250	040450	CF250ALIS+V	
320	040459	CF320ALIS+V	

* Available also in steel (item CF..AQIS+V) in Ø 32 ÷ 320, see page 1.98.1

Narrow rear clevis in aluminium with screws and pin CFS..ALIS+VP

For cylinder Ø mm	Code	Item	Compliance
32	042110	CFS032ALIS+VP	 AB6
40	042111	CFS040ALIS+VP	
50	042112	CFS050ALIS+VP	
63	042113	CFS063ALIS+VP	
80	042114	CFS080ALIS+VP	
100	042115	CFS100ALIS+VP	
125	042116	CFS125ALIS+VP	
160	042117	CFS160ALIS+VP	
200	042118	CFS200ALIS+VP	
250	042148	CFS250ALIS+VP	

Narrow rear clevis in aluminium* with screws CFS..ALIS+V

For cylinder Ø mm	Code	Item	Compliance
32	040451	CFS032ALIS+V	 AB6
40	040452	CFS040ALIS+V	
50	040453	CFS050ALIS+V	
63	040454	CFS063ALIS+V	
80	040455	CFS080ALIS+V	
100	040456	CFS100ALIS+V	
125	040457	CFS125ALIS+V	
160	040458	CFS160ALIS+V	
200	040498	CFS200ALIS+V	
250	042499	CFS250ALIS+V	

Available also in steel (item CFS..AQIS+V) in Ø 32 ÷ 125, see page 1.98.1

Rear eye in aluminium* with screws CM..ALIS+V

For cylinder Ø mm	Code	Item	Compliance
32	042061	CM032ALIS+V	 MP4
40	042062	CM040ALIS+V	
50	042063	CM050ALIS+V	
63	042064	CM063ALIS+V	
80	042065	CM080ALIS+V	
100	042066	CM100ALIS+V	
125	042067	CM125ALIS+V	
160	042068	CM160ALIS+V	
200	042069	CM200ALIS+V	
250	042070	CM250ALIS+V	
320	042071	CM320ALIS+V	



Narrow rear eye with bearing (DIN 648K) in aluminium* with screws CMS..ALIS+V

For cylinder Ø mm	Code	Item	Compliance
32	042101	CMS032ALIS+V	 MP6
40	042102	CMS040ALIS+V	
50	042103	CMS050ALIS+V	
63	042104	CMS063ALIS+V	
80	042105	CMS080ALIS+V	
100	042106	CMS100ALIS+V	
125	042107	CMS125ALIS+V	
160	042108	CMS160ALIS+V	
200	042109	CMS200ALIS+V	
250	040160	CMS250ALIS+V	
320	040197	CMS320ALIS+V	



Available also in steel (item CM..AQIS+V) in Ø 32 ÷ 320, see page 1.98.2

Available also in steel (item CMS..AQIS+V) in Ø 32 ÷ 125, see page 1.98.2



Flange in aluminium with screws FLV..ALIS+V

	For cylinder Ø mm	Code	Item	Compliance
	32	042150	FLV032ALIS+V	  MF1 / MF2
40	042151	FLV040ALIS+V		
50	042152	FLV050ALIS+V		
63	042153	FLV063ALIS+V		
80	042154	FLV080ALIS+V		
100	042155	FLV100ALIS+V		
125	042156	FLV125ALIS+V		
160	042157	FLV160ALIS+V		
200	042158	FLV200ALIS+V		



Flange in steel with screws FLV..AQIS+V

	For cylinder Ø mm	Code	Item	Compliance
	32	042119	FLV032AQIS+V	  MF1 / MF2
40	042120	FLV040AQIS+V		
50	042121	FLV050AQIS+V		
63	042122	FLV063AQIS+V		
80	042123	FLV080AQIS+V		
100	042124	FLV100AQIS+V		
125	042125	FLV125AQIS+V		
160	042126	FLV160AQIS+V		
200	042127	FLV200AQIS+V		
250	042128	FLV250AQIS+V		
320	040683	FLV320AQIS+V		

Rear 90° hinge in aluminium* with screws ASV..ALIS+V



	For cylinder Ø mm	Code	Item	Compliance
	32	042081	ASV032ALIS+V	 AB7  RP 107P
40	042082	ASV040ALIS+V		
50	042083	ASV050ALIS+V		
63	042084	ASV063ALIS+V		
80	042085	ASV080ALIS+V		
100	042086	ASV100ALIS+V		
125	042087	ASV125ALIS+V		
160	042088	ASV160ALIS+V		
200	042089	ASV200ALIS+V		
250	042090	ASV250ALIS+V		

Clevis hinge in aluminium with screws ASF..ALIS+V

	For cylinder Ø mm	Code	Item	Compliance
	32	042161	ASF032ALIS+V	 RP 107P
40	042162	ASF040ALIS+V		
50	042163	ASF050ALIS+V		
63	042164	ASF063ALIS+V		
80	042165	ASF080ALIS+V		
100	042166	ASF100ALIS+V		
125	042167	ASF125ALIS+V		
160	042168	ASF160ALIS+V		
200	042169	ASF200ALIS+V		
250	042170	ASF250ALIS+V		



*Available also in steel (item ASV..AQIS) in Ø 32 ÷ 125, see page 1.98.3

Adjustable center trunnion (tie rods)* in steel with grains CT..AQIS+GR

	For cylinder Ø mm	Code	Item	Compliance
	32	040581	CT032AQIS+GR	 MT4
40	040582	CT040AQIS+GR		
50	040583	CT050AQIS+GR		
63	040584	CT063AQIS+GR		
80	040585	CT080AQIS+GR		
100	040586	CT100AQIS+GR		
125	040587	CT125AQIS+GR		
160	040588	CT160AQIS+GR		
200	040589	CT200AQIS+GR		

*For trunnion mounted on the cylinder, please order together with the cylinder.

Non adjustable round trunnion (threaded)* in steel CTN..AQIS

	For cylinder Ø mm	Code	Item	Compliance
	32	040052	CTN032AQIS	 MT4
40	040053	CTN040AQIS		
50	048590	CTN050AQIS		
63	040564	CTN063AQIS		
80	040096	CTN080AQIS		
100	040097	CTN100AQIS		
125	040098	CTN125AQIS		
160	040099	CTN160AQIS		
200	040100	CTN200AQIS		
250	040110	CTN250AQIS		
320	040590	CTN320AQIS		

*For trunnion mounted on the cylinder, please order together with the cylinder, indicating the XV dimension (cannot be modified), see page 1.98.7

Center trunnion (profile barrel)* in steel with grains CTS..AQIS+GR

	For cylinder Ø mm	Code	Item	Compliance
	32	040601	CTS032AQIS+GR	 MT4
	40	040602	CTS040AQIS+GR	
	50	040603	CTS050AQIS+GR	
	63	040604	CTS063AQIS+GR	
	80	040605	CTS080AQIS+GR	
	100	040606	CTS100AQIS+GR	
	125	040607	CTS125AQIS+GR	

*For trunnion mounted on the cylinder, please order together with the cylinder.

Center trunnion for heads in steel with screws CTA..AQIS+V

	For cylinder Ø mm	Code	Item	Compliance
	32	040591	CTA032AQIS+V	 MT5/MT6
	40	040592	CTA040AQIS+V	
	50	040593	CTA050AQIS+V	
	63	040594	CTA063AQIS+V	
	80	040595	CTA080AQIS+V	
	100	040596	CTA100AQIS+V	
	125	040598	CTA125AQIS+V	

Front clevis in aluminium with screws CFA..ALIS+V

	For cylinder Ø mm	Code	Item	Compliance
	32	040473	CFA032ALIS+V	 MP7
	40	040474	CFA040ALIS+V	
	50	040017	CFA050ALIS+V	
	63	040471	CFA063ALIS+V	
	80	040051	CFA080ALIS+V	
	100	040478	CFA100ALIS+V	
	125	040475	CFA125ALIS+V	
	200	040479	CFA200ALIS+V	

Low foot in steel* with screws PB..AQIS+V

	For cylinder Ø mm	Code	Item	Compliance
	32	042129	PB032AQIS+V	 MS1
	40	042130	PB040AQIS+V	
	50	042131	PB050AQIS+V	
	63	042132	PB063AQIS+V	
	80	042133	PB080AQIS+V	
	100	042134	PB100AQIS+V	
	125	042135	PB125AQIS+V	
	160	042136	PB160AQIS+V	
	200	042137	PB200AQIS+V	
	250	042138	PB250AQIS+V	
	320	042139	PB320AQIS+V	

*Supplied individually and available also in version foot, made of aluminium (item P..ALIS), in Ø 32 + 250, see page 1.97.6

Rear 90° hinge with bearing (DIN 648K) in steel ASS..AQIS

	For cylinder Ø mm	Code	Item	Compliance
	32	040551	ASS032AQIS	 CS7
	40	040552	ASS040AQIS	
	50	040553	ASS050AQIS	
	63	040554	ASS063AQIS	
	80	040555	ASS080AQIS	
	100	040556	ASS100AQIS	
	125	040557	ASS125AQIS	

Rear 90° hinge in aluminium AS..ALIS

	For cylinder Ø mm	Code	Item	Compliance
	32	040361	AS032ALIS	 6431
	40	040362	AS040ALIS	
	50	040363	AS050ALIS	
	63	040364	AS063ALIS	
	80	040365	AS080ALIS	
	100	040366	AS100ALIS	
	125	040367	AS125ALIS	
	160	040368	AS160ALIS	
	200	040369	AS200ALIS	

Support for center trunnion* in steel ST..AQIS

	For cylinder Ø mm	Code	Item	Compliance
	32	040681	ST032AQIS	 AT4
	40-50	040682	ST040/050AQIS	
	63-80	040684	ST063/080AQIS	
	100-125	040686	ST100/125AQIS	
	160-200	040688	ST160/200AQIS	

*Supplied individually

Plate for valves* PSV..

	For cylinder Ø mm	Code	Item	Compatibilità taglia valvola*
	32-40	071458	PSV/A1/AMA-32-40	1/8" - 1/4"
	50-63	071459	PSV/A1/AMA-50-63	
	80÷125	071460	PSV/A1/AMA-80-100-125	1/8" - 1/4" - 1/2"
	160-200	070822	PSV/A1/AMT-160-200	1/4" - 1/2"

*For valves series A1 see from page 2.20.1

Anti-rotating pin with seeger* in steel SEC..ARAQIS

	For cylinder Ø mm	Code	Item	Compliance
	32	040571	SEC032ARAQIS	
	40	040572	SEC040ARAQIS	
	50	040573	SEC050ARAQIS	
	63	040574	SEC063ARAQIS	
	80	040575	SEC080ARAQIS	
	100	040576	SEC100ARAQIS	
	125	040577	SEC125ARAQIS	
	160	040578	SEC160ARAQIS	
	200	040579	SEC200ARAQIS	

*Supplied with 1 seeger

Pin with seeger* in steel SEC..AQIS

	For cylinder Ø mm	Code	Item	Compliance
	32	040261	SEC032AQIS	
	40	040262	SEC040AQIS	
	50	040263	SEC050AQIS	
	63	040264	SEC063AQIS	
	80	040265	SEC080AQIS	
	100	040266	SEC100AQIS	
	125	040267	SEC125AQIS	
	160	040268	SEC160AQIS	
	200	040269	SEC200AQIS	
	250	040270	SEC250AQIS	
	320	040460	SEC320AQIS	

*Supplied with 2 seeger

Bracket AS.. for magnetic reed switches T groove

	For cylinder Ø mm	Code	Item	Cylinder matching
	32 ÷ 40	072908	AS101	AMA BMA
	50 ÷ 63	072909	AS102	
	80 ÷ 100	072910	AS103	
	125	072911	AS104	
	32 ÷ 40	072912	AS105	
	50 ÷ 100	072913	AS106	AMT BMT
	125	072909	AS102	
	160 ÷ 200	072910	AS103	
	250 ÷ 320	072917	AS110	

Bracket AS.. for high-temperatures magnetic reed switches

	For cylinder Ø mm	Code	Item	Cylinder matching
	32 ÷ 40	077838	AS114	AMA BMA
	50 ÷ 63	077651	AS113	
	80	074055	AS112	
	100	077839	AS115	
	125	074007	AS116	
	32 ÷ 40	074041	AS117	AMT BMT
	50 ÷ 63	074043	AS118	
	80 ÷ 100	074087	AS119	
	125	074155	AS120	
	160 ÷ 200	074169	AS121	

Magnetic reed switch T groove ASV..

	For cylinder Ø mm	Code	Item	Cylinder matching
	32 ÷ 320	070946	ASV1C525	AMA BMA AMT* BMT*
		071863	ASV1C550	
		071864	ASV1C51K	
		071189	ASV1C5M8	
		073639	ASV4D225	
		070246	ASV4D2M8	
		074900	ASV7N225	
		070247	ASV7N2M8	
		070372	ASV7M2M8	
		072918	ASV1H525	

*With bracket type AS.. for magnetic reed switches T groove

High-temperatures magnetic reed switches ASH..

	For cylinder Ø mm	Code	Item	Cylinder matching
	32 ÷ 320	074047	ASH6C550	AMA* BMA* AMT* BMT*

*With bracket type AS.. for high-temperatures magnetic reed switches

Magnetic reed switch C groove ASC..

	For cylinder Ø mm	Code	Item	Cylinder matching
	32 ÷ 320	070248	ASC1C525	AMA BMA
		070249	ASC7N2M8	
		070382	ASC7M2M8	

ATEX magnetic reed switch T groove MK..

	For cylinder Ø mm	Code	Item	Compliance	Cylinder matching
	32 ÷ 320	071120	MK500A		AMA BMA AMT* BMT*
		071108	MK502A		

*With bracket type AS.. for magnetic reed switches T groove

Notes

Horizontal lines for note-taking

ROUND CYLINDERS

Series M



Find out our
key products



Solution for most applications



Easy and intuitive choice



Excellent value for money



Wide availability



Fast delivery



Features and certifications

Series of round cylinders not conforming to standards, available in bores from Ø 32 to 63, single acting or double acting, magnetic or non magnetic, with or without cushioning. The heads joined to the barrel through rolling ensure perfect tightening. Supplied as standard in compliance with Reach and RoHS directives, and SIL certificated. On request, they can be also supplied according to the 2014/34/EU ATEX Directive.



Type MSM Ø 32 ÷ 63 da pag. 1.10.20



Round cylinders not conforming to standards, available in bores from Ø 32 to 63, single acting, magnetic. Heads joined to the barrel through rolling ensure perfect tightening. Supplied with rod nut and head nut. Possibility of applying one or more magnetic reed switches.

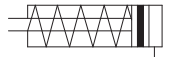

Type MDM Ø 32 ÷ 63 da pag. 1.10.40



Round cylinders not conforming to standards, available in bores from Ø 32 to 63, double acting, magnetic. Heads joined to the barrel through rolling ensure perfect tightening. Supplied with rod nut and head nut. Possibility of applying one or more magnetic reed switches.

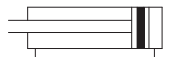

Type MDMA Ø 32 ÷ 63 da pag. 1.10.60



Round cylinders not conforming to standards, available in bores from Ø 32 to 63, double acting, magnetic, adjustable cushioning. Heads joined to the barrel through rolling ensure perfect tightening. Supplied with rod nut and head nut. Possibility of applying one or more magnetic reed switches.

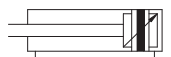

Options		
Description	Symbol	Suffix
Rear spring (available only for MSM type)		T
Stainless Steel AISI 304 rod		K
Read head without thread with radial connection		T1
Read head without thread with axial connection (not available for MDMA type)		T2
Through rod (not available for MSM type)		P
FKM seals	-20°C ÷ +150°C 	V
Low temperature seals	-40°C ÷ +80°C 	BT
Special male thread (indicate the requested thread. E.g.: R-M 10x1,5; the dimension AM of the special thread will be the same as the standard; cylinder will be supplied without rod nut; for further information please contact the sales department)		R-M..
ATEX versions on request (only with K; for further information please contact the sales department)		/ATEX
Special versions on request		/S

The options, when this is possible, can be combined with each other. For options matching see from page 1.10.4; For code key see from page 1.10.5

Options matching

Series	Bore	Model	Standard options matching								
			T	K	T1	T2	P	V	BT	R-M.. ⁽¹⁾	/ATEX ⁽²⁾
MSM	Ø 32 ÷ 63	Standard	●	●	●	●	-	●	●	●	●
		Rear spring (T)		●	●	-	-	●	●	●	●
		Stainless Steel rod (K)	●		●	●	-	●	●	●	●
		Read head without thread with radial connection (T1)	●	●		-	-	●	●	●	●
		Read head without thread with axial connection (T2)	-	●	-		-	●	●	●	●
MDM	Ø 32 ÷ 63	Standard	-	●	●	●	●	●	●	●	●
		Stainless Steel rod (K)	-		●	●	●	●	●	●	●
		Read head without thread with radial connection (T1)	-	●		-	-	●	●	●	●
		Read head without thread with axial connection (T2)	-	●	-		-	●	●	●	●
		Through rod (P)	-	●	-	-		●	●	●	●
MDMA	Ø 32 ÷ 63	Standard	-	●	●	-	●	●	●	●	●
		Stainless Steel rod (K)	-		●	-	●	●	●	●	●
		Read head without thread with radial connection (T1)	-	●		-	-	●	●	●	●
		Through rod (P)	-	●	-	-		●	●	●	●

Key
 ● allowed matching; - not allowed matching

Options matching - notes

- (1) Option **R-M..** require to indicate the desired thread. For further information please contact the sales department.
- (2) In the **/ATEX** versions, is required to mount the stainless steel rod (options **K**). For further information please contact the sales department.

Code key

Bore	/	Stroke	Type	Options					/	ATEX version	Special version
40	/	80	MDM		K	P			/		
Ø 32, 40, 50, 63		10 mm ÷ 1000 mm (MSM tyoe up to 50 mm)	MSM Single acting Magnetic MDM Double acting Magnetic MDMA Double acting Magnetic With cushioning	T	K	T1 T2* P	V BT	R-M..		CE Ex II 2G Ex h IIC T5 Gb II 2D Ex h IIC T100°C Db	S

How to order				Notes
Bore	Stroke	Type	Options	Options in the same grid are alternative to each others. For further information on options and their matching, see page 1.10.3 and 1.10.4 *Not available for type MDMA For standard materials see the table below. For further information on the ATEX 2014/34/EU Directive, on classifications and protections, see from page III.1
40	/ 80	MDM	K P	

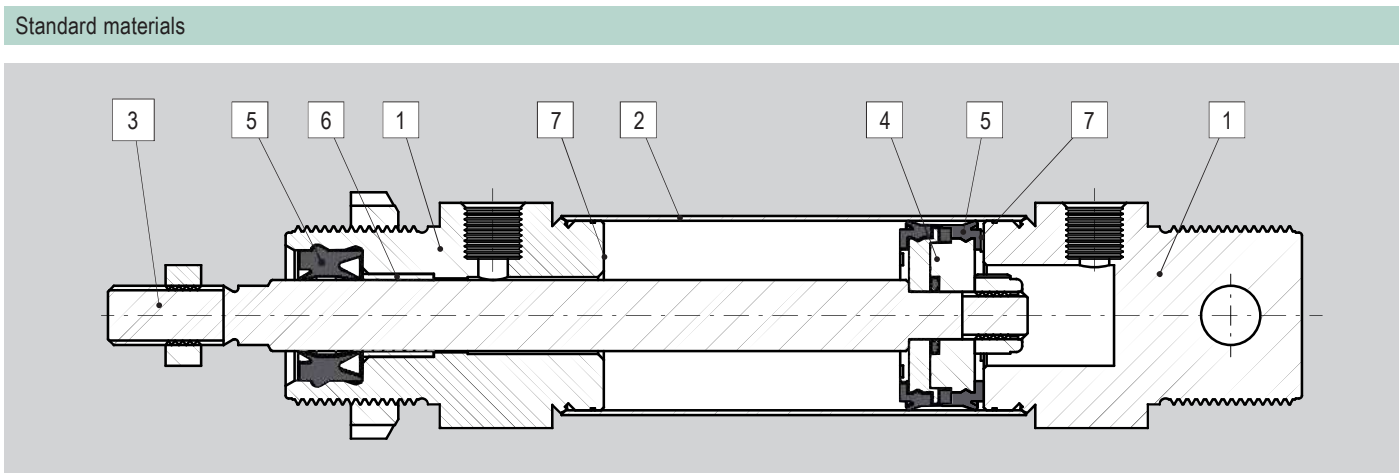

Position	Description	Materials
1	Heads	Anodised aluminium
2	Tube	Stainless Steel AISI 304
3	Rod	Steel C45 chrom-plated
4	Piston	Aluminium
5	Seals	NBR / Polyurethane (PU)
6	Bushing	Self-lubricating sintered bronze
7	Dumper	NBR

Accessories

1 - CYLINDERS

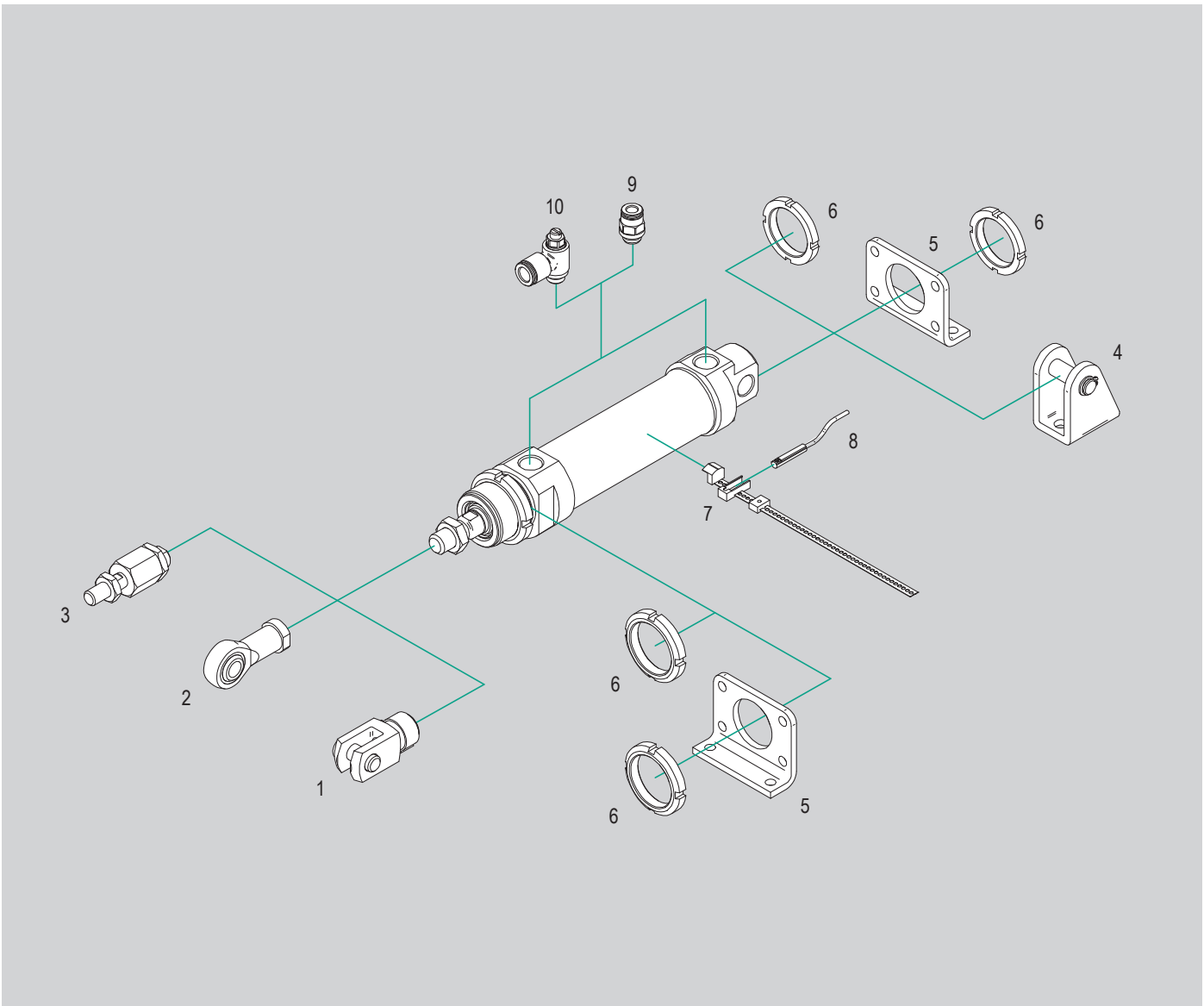

N.	Cylinder bore	Item	Description	Compliance	Matching			Code page	Data sheet page
					MSM	MDM	MDMA		
1	Ø 32 ÷ 63	FF..	ISO female clevis with clip	ISO 8140	●	●	●	1.85.10	
		FFP..	ISO female clevis with pin and seeger		●	●	●		
		FFN..	ISO female clevis (body only)		●	●	●		
2	Ø 32 ÷ 63	RF..SE	Bearing head (DIN 648K) with female thread	ISO 8139	●	●	●	1.10.90	1.90.1
3	Ø 32 ÷ 63	GB..	Bearing - Self-aligning articulated coupling	-	●	●	●	1.10.90	1.90.10
4	Ø 32 ÷ 63	CF..M	Rear clevis	-	●	●	●		1.96.2
5	Ø 32 ÷ 63	P..	Foot-flange	-	●	●	●		1.96.1
6	Ø 32 ÷ 63	GH..	Heads nut	-	●	●	●	1.10.91	1.120.1
7	Ø 32 ÷ 63	AFR..	Bracket for T type magnetic reed switches	-	●	●	●		1.110.10
8	Ø 32 ÷ 63	ASV..	Magnetic reed switch T groove	2014/34/UE	●	●	●		1.113.1
		MK..	ATEX magnetic reed switch T groove		-	●	●	●	
9	Ø 32 ÷ 63	R..	Push-in fittings	-	●	●	●	4.2.1	
10	Ø 32 ÷ 63	V..C	Flow controls, for cylinders	-	●	●	●	4.94.1	

Key
 ● matching accessory; - not matching accessory

Round cylinders series M

Series MSM



Main features

32 ÷ 63

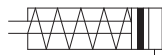

MSM

Bores Ø

Single acting
Magnetic

Type



Technical data

Bore Ø mm	32			40			50			63			
Fluid	Filtered compressed air with or without lubrication. Lubrication, if started, must be continued.												
Pressure range	1 ÷ 10 bar												
Temperature range	-20°C ÷ +80°C (standard)			-20°C ÷ +150°C (V)			-40°C ÷ +80°C (BT)						
Strokes	10 ÷ 50 mm												
Rod thread	M10x1,25			M12x1,25			M16x1,5						
Thrust force at 6 bar (N)	482			754			1178			1869			
Traction force (N)	Stroke (mm)	10	25	50	10	25	50	10	25	50	10	25	50
	min.	57	51	40	98	86	64	147	130	101	147	130	101
	max.	62	62	62	105	105	105	158	158	158	158	158	158

Standard strokes

Stroke mm	MSM Bore Ø mm			
	32	40	50	63
10				
25				
50				

Key

■ Standard stroke

Standard dimensions

Type: **MSM**

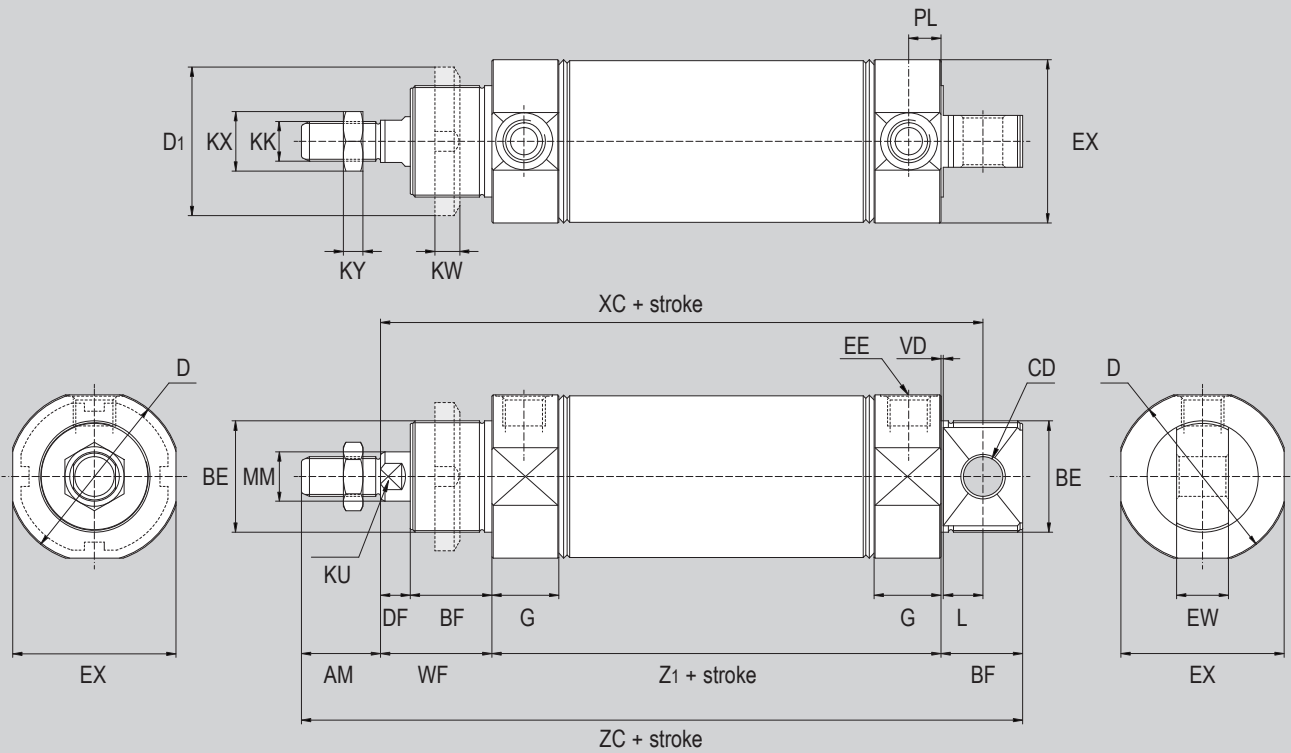

\varnothing (mm)	AM	BE	BF	CD	$\varnothing D$	$\varnothing D_1$	DF	EE	EX	EW	G	KK
32	22	M30x1,5	26	10	41	42	8	G1/8"	38	16	19	M10x1,25
40	24	M38x1,5	30	12	49	50	9	G1/4"	45	18	25	M12x1,25
50	32	M45x1,5	33	16	57	60	11	G1/4"	53	21	25	M16x1,5
63	32	M45x1,5	33	16	70	60	12	G3/8"	66	21	27	M16x1,5

\varnothing (mm)	KU	KW	KX	KY	L	MM	PL	VD	WF	XC	Z1	ZC
32	10	8	17	6	13	12	9	2	34	117,5	69,5	151,5
40	13	10	19	6	15	16	12	3	39	139,6	84,6	177,6
50	17	10	24	8	16	20	12	3	44	147,2	86,2	195,2
63	17	10	24	8	16	20	13	3	45	156,2	94,2	204,2

Standard dimensions

Type: ...T

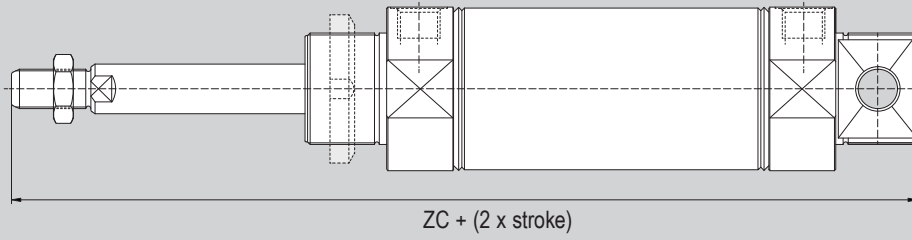

Type: ...T1

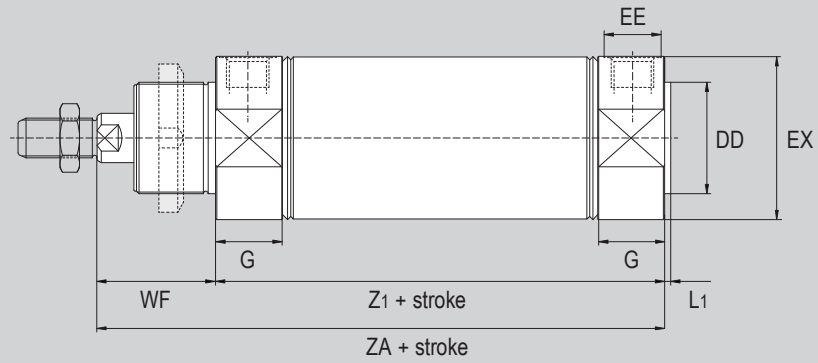

Type: ...T2

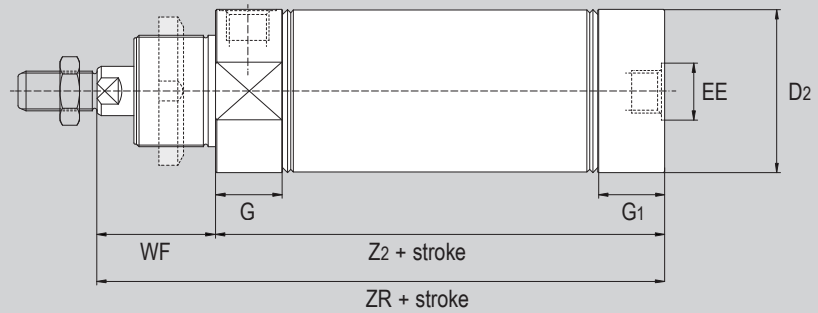

\varnothing (mm)	G	G1	WF	ZA	ZC	ZR	Z1	Z2	L1	$\varnothing DD$	$\varnothing D2$	EX	EE
32	19	15	34	103,5	151,5	99,5	69,5	65,5	3	30	34	38	G1/8"
40	25	18	39	123,6	177,6	116,6	84,6	77,6	4	38	42	45	G1/4"
50	25	25	44	130,2	195,2	130,2	86,2	86,2	4	45	53	53	G1/4"
63	27	27	45	139,2	204,2	139,2	94,2	94,2	4	45	66	66	G3/8"

Round cylinders series M

Series MDM



Main features

32 ÷ 63

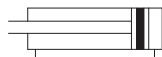

MDM

Bores Ø

Double acting
Non magnetic

Type



Technical data

Bore Ø mm	32	40	50	63
Fluid	Aria compressa filtrata con o senza lubrificazione. La lubrificazione se utilizzata deve essere ininterrotta.			
Pressure range	1 ÷ 10 bar			
Temperature range	-20°C ÷ +80°C (standard)	-20°C ÷ +150°C (V)	-40°C ÷ +80°C (BT)	
Standard strokes	10 ÷ 1000 mm			
Rod thread	M10x1,25	M12x1,25	M16x1,5	

Standard strokes

Stroke mm	MDM Bore Ø mm			
	32	40	50	63
10				
25				
50				
80				
100				
125				
160				
200				
250				
320				
400				
500				

Key

Standard stroke

1.10.40

Standard dimensions

Type: **MDM**

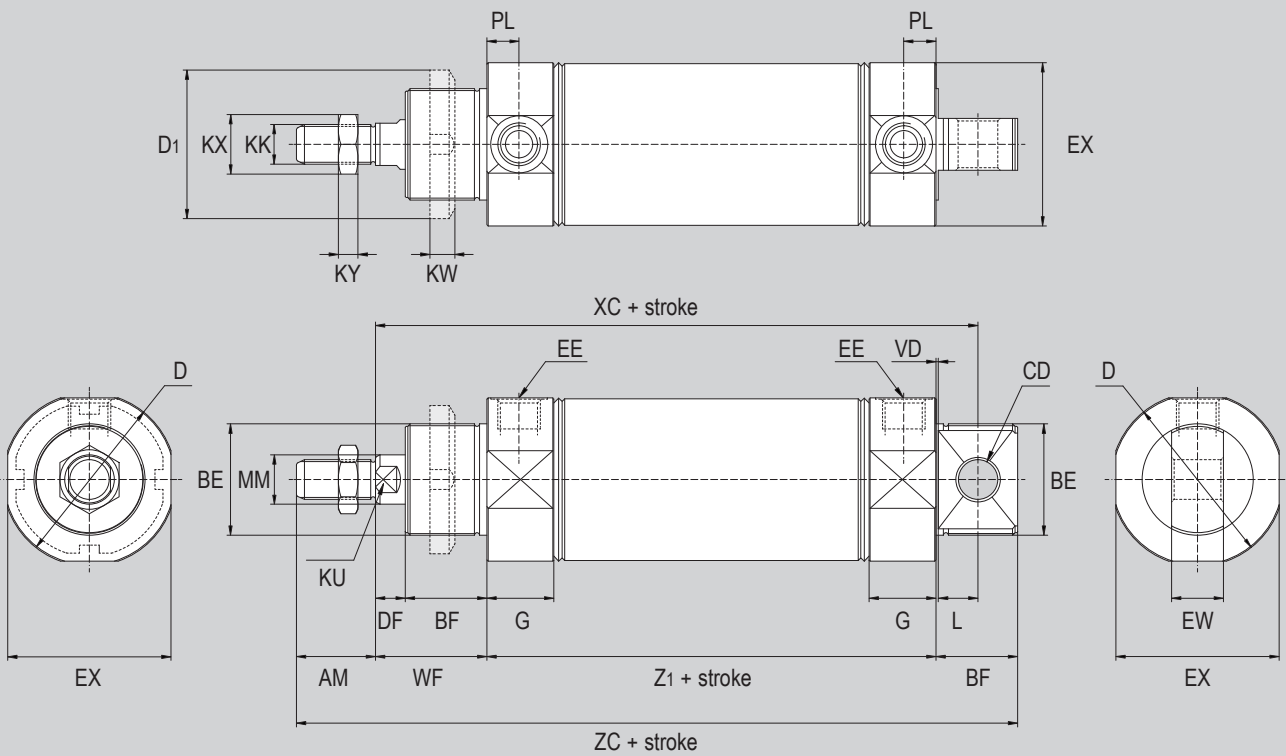

1 - CYLINDERS

\emptyset (mm)	AM	BE	BF	CD	$\emptyset D$	$\emptyset D_1$	DF	EE	EX	EW	G	KK
32	22	M30x1,5	26	10	41	42	8	G1/8"	38	16	19	M10x1,25
40	24	M38x1,5	30	12	49	50	9	G1/4"	45	18	25	M12x1,25
50	32	M45x1,5	33	16	57	60	11	G1/4"	53	21	25	M16x1,5
63	32	M45x1,5	33	16	70	60	12	G3/8"	66	21	27	M16x1,5

\emptyset (mm)	KU	KW	KX	KY	L	MM	PL	VD	WF	XC	Z1	ZC
32	10	8	17	6	13	12	9	2	34	117,5	69,5	151,5
40	13	10	19	6	15	16	12	3	39	139,6	84,6	177,6
50	17	10	24	8	16	20	12	3	44	147,2	86,2	195,2
63	17	10	24	8	16	20	13	3	45	156,2	94,2	204,2

Standard dimensions

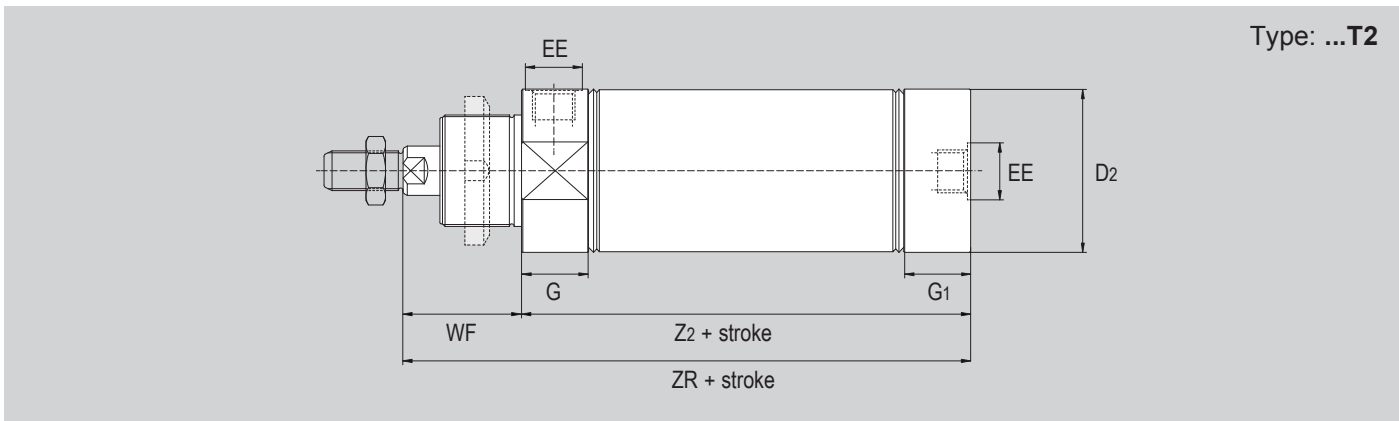
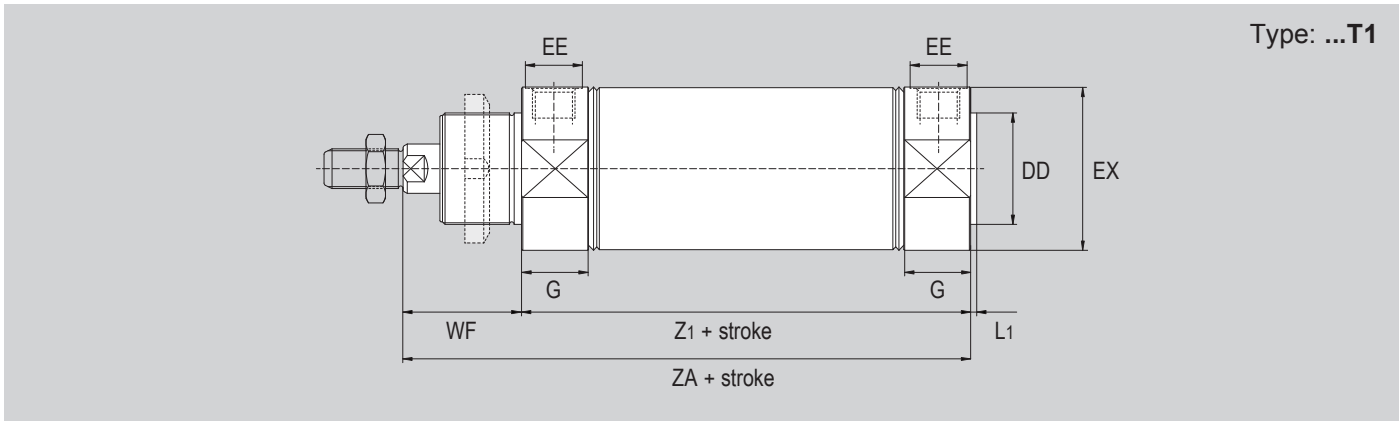
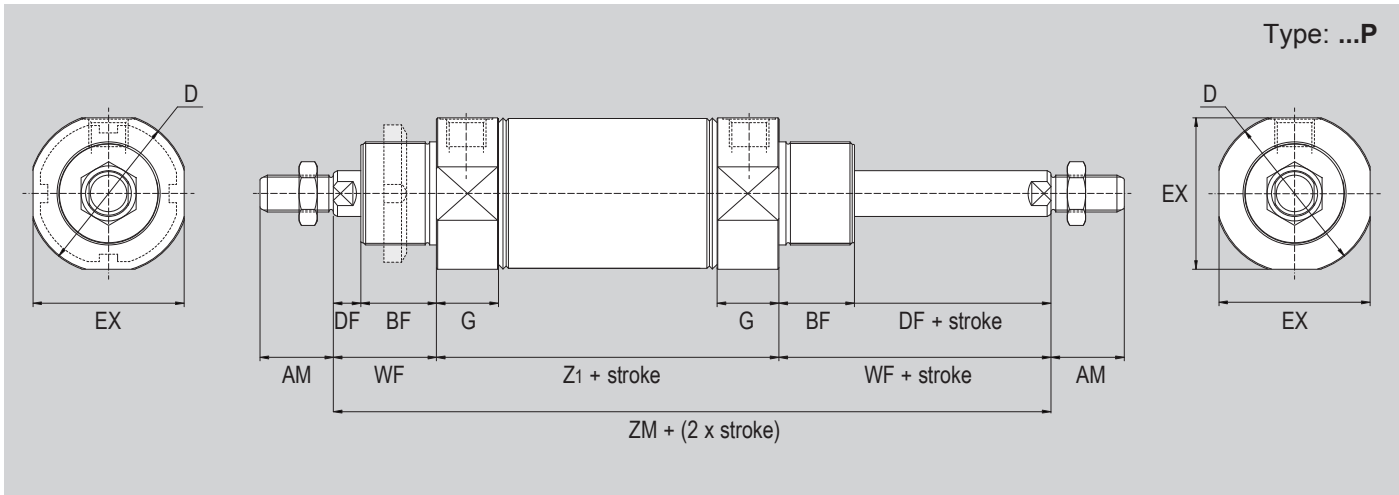

Ø (mm)	AM	G	G1	BF	WF	DF	ZA	ZM	ZR	Z1	Z2	L1	ØD	ØDD	ØD2	EX	EE
32	22	19	15	26	34	8	103,5	137,5	99,5	69,5	65,5	3	41	30	34	38	G1/8"
40	24	25	18	30	39	9	123,6	162,6	116,6	84,6	77,6	4	49	38	42	45	G1/4"
50	32	25	25	33	44	11	130,2	174,2	130,2	86,2	86,2	4	57	45	53	53	G1/4"
63	32	27	27	33	45	12	139,2	184,2	139,2	94,2	94,2	4	70	45	66	66	G3/8"

Round cylinders series M

Series MDMA



Main features

32 ÷ 63

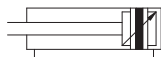

MDMA

Bores Ø

Double acting
Magnetic
With cushioning

Type



Technical data

Bore Ø mm	32	40	50	63
Fluid	Filtered compressed air with or without lubrication. Lubrication, if started, must be continued.			
Pressure range	1 ÷ 10 bar			
Temperature range	-20°C ÷ +80°C (standard)	-20°C ÷ +150°C (V)	-40°C ÷ +80°C (BT)	
Strokes	25 ÷ 1000 mm			
Rod thread	M10x1,25	M12x1,25	M16x1,5	

Standard strokes

Stroke mm	MDMA Bore Ø mm			
	32	40	50	63
25				
50				
80				
100				
125				
160				
200				
250				
320				
400				
500				

Key

■ Standard stroke

Standard dimensions

Type: MDMA

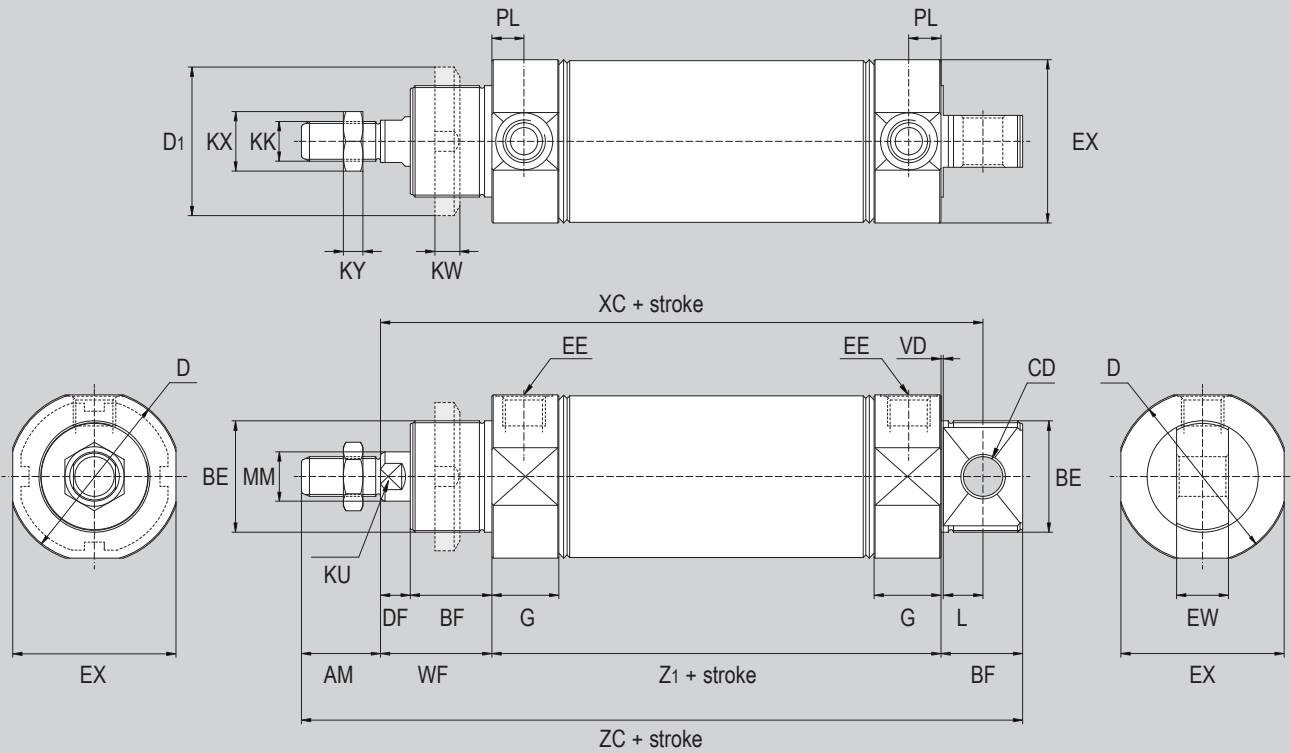

\varnothing (mm)	AM	BE	BF	CD	$\varnothing D$	$\varnothing D_1$	DF	EE	EX	EW	G	KK
32	22	M30x1,5	26	10	41	42	8	G1/8"	38	16	19	M10x1,25
40	24	M38x1,5	30	12	49	50	9	G1/4"	45	18	25	M12x1,25
50	32	M45x1,5	33	16	57	60	11	G1/4"	53	21	25	M16x1,5
63	32	M45x1,5	33	16	70	60	12	G3/8"	66	21	27	M16x1,5



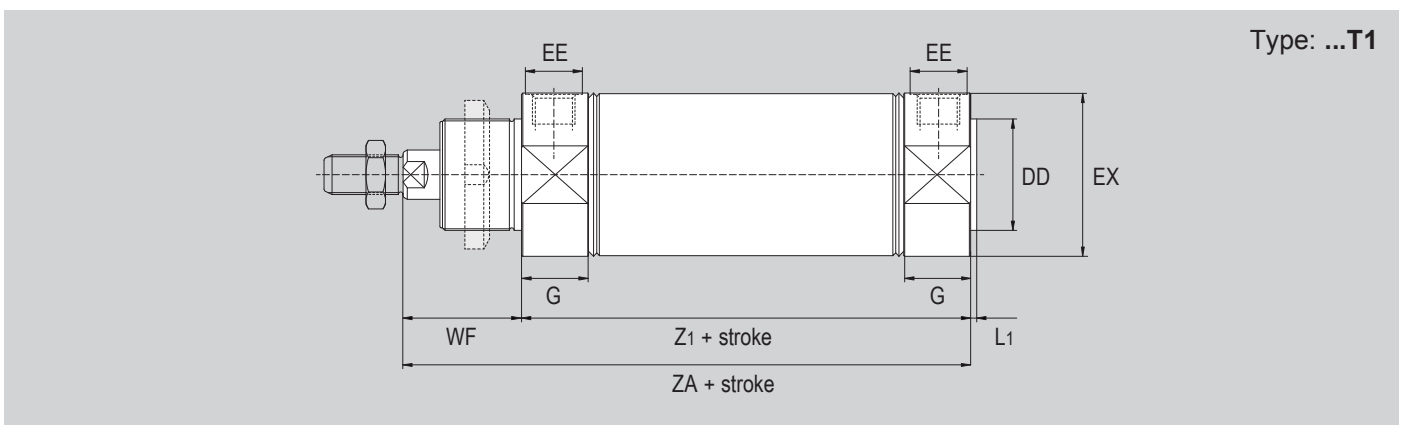
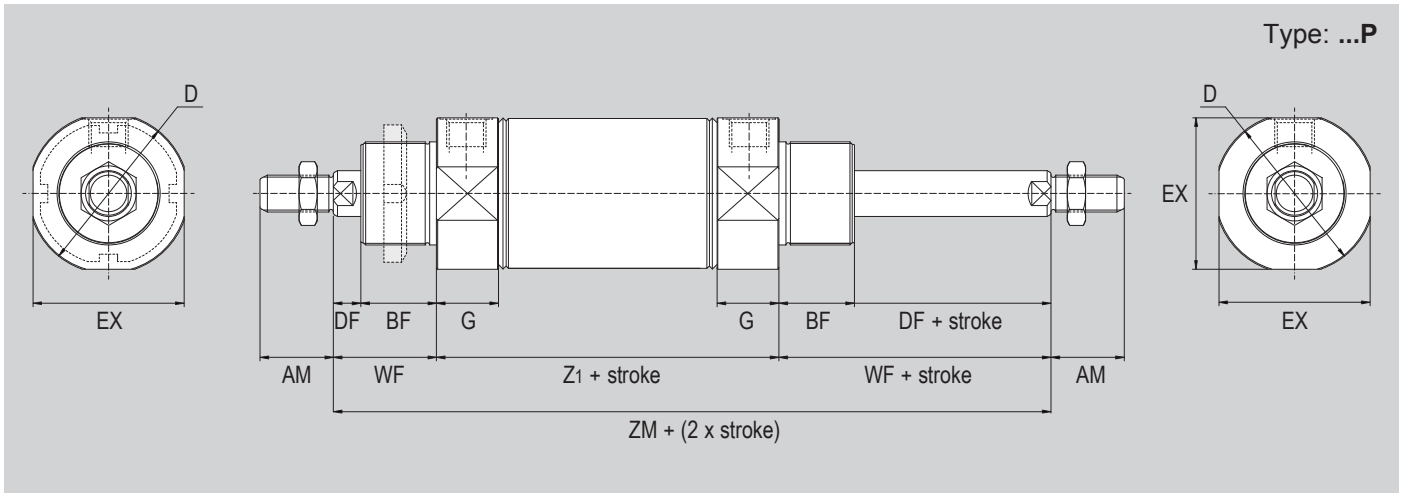

\varnothing (mm)	KU	KW	KX	KY	L	MM	PL	VD	WF	XC	Z1	ZC
32	10	8	17	6	13	12	9	2	34	117,5	69,5	151,5
40	13	10	19	6	15	16	12	3	39	139,6	84,6	177,6
50	17	10	24	8	16	20	12	3	44	147,2	86,2	195,2
63	17	10	24	8	16	20	13	3	45	156,2	94,2	204,2

Standard dimensions





Ø (mm)	AM	G	BF	WF	DF	ZA	ZM	Z1	L1	ØD	ØDD	EX	EE
32	22	19	26	34	8	103,5	137,5	69,5	3	41	30	38	G1/8"
40	24	25	30	39	9	123,6	162,6	84,6	4	49	38	45	G1/4"
50	32	25	33	44	11	130,2	174,2	86,2	4	57	45	53	G1/4"
63	32	27	33	45	12	139,2	184,2	94,2	4	70	45	66	G3/8"



Female clevis with clip FF..ISO

	For cylinder Ø mm	Code	Item	Compliance 
	32	041004 	FF10ISO	
	40	041005 	FF12ISO	
	50	041006 	FF16ISO	
	63			





Female clevis with pin and seeger FFP..ISO

	For cylinder Ø mm	Code	Item	Compliance 
	32	041051	FFP10ISO	
	40	041040	FFP12ISO	
	50	041013	FFP16ISO	
	63			

Female clevis (body only) FFN..ISO

	For cylinder Ø mm	Code	Item	Compliance 
	32	041014	FFN10ISO	
	40	041016	FFN12ISO	
	50	041012	FFN16ISO	
	63			



Bearing heads (DIN 648K) with female thread RF..SE

	For cylinder Ø mm	Code	Item	Compliance 
	32	041554 	RF10SE	
	40	041555 	RF12SE	
	50	041557 	RF16SE	
	63			

Self-aligning articulated coupling GB..

	For cylinder Ø mm	Code	Item	Compliance -
	32	041704	GB040	
	40	041706	GB060	
	50	041708	GB0100	
	63			

Rear clevis in steel with pin and seeger CF..M

	For cylinder Ø mm	Code	Item	Compliance 
	32	040212	CF32M	
	40	040213	CF40M	
	50	040214	CF50-63M	
	63			

Kit composed by rear clevis, pin and two seeger.

Foot-flange in steel P..AQM



	For cylinder Ø mm	Code	Item	Compliance -
	32	040054	P032AQM	
	40	040055	P040AQM	
	50	040056	P050AQM	
	63	040057	P063AQM	

For mounting on cylinder require heads nut GH..AQM

Head nuts in steel GH..AQM



	For cylinder Ø mm	Code	Item	Compliance -
	32	040066	GH032AQM	
	40	040067	GH040AQM	
	50	040068	GH050/063AQM	
	63			

Magnetic reed switch T groove ASV..

	For cylinder Ø mm	Code	Item	Cylinder matching
	32 ÷ 63	070946 	ASV1C525	MSM* MDM* MDMA*
		071863	ASV1C550	
		071864	ASV1C51K	
		071189	ASV1C5M8	
		073639	ASV4D225	
		070246 	ASV4D2M8	
		074900	ASV7N225	
		070247	ASV7N2M8	
		070372	ASV7M2M8	
		072920	ASV1H510	
		072918	ASV1H525	

*With bracket type AFR1063 for magnetic reed switches T groove

ATEX magnetic reed switch T groove MK..

	For cylinder Ø mm	Code	Item	Compliance	Cylinder matching
	32 ÷ 63	071120	MK500A		MSM* MDM* MDMA*
		071108	MK502A		

*With bracket type AFR1063 for magnetic reed switches T groove

Bracket AFR.. for magnetic reed switches T groove

	For cylinder Ø mm	Code	Item	Compliance
	32 ÷ 63	072907	AFR1063	-

ROUND CYLINDERS

Series R



Find out our
key products



Solution for most applications



Easy and intuitive choice



Excellent value for money



Wide availability



Fast delivery



Features and certifications

Series of round cylinders not conforming to standards, available in bores from Ø 32 to 63, single acting or double acting, magnetic or non magnetic, with or without cushioning. The heads joined to the barrel through rolling ensure perfect tightening. Supplied as standard in compliance with Reach and RoHS directives, and SIL certificated. On request, they can be also supplied according to the 2014/34/EU ATEX Directive.



Type RS Ø 32 ÷ 63 from page 1.11.20



Round cylinders not conforming to standards, available in bores from Ø 32 to 63, single acting, non magnetic. Heads joined to the barrel through rolling ensure perfect tightening. Supplied with rod nut and head nut.

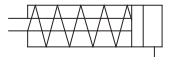

Type RD Ø 32 ÷ 63 from page 1.11.40



Round cylinders not conforming to standards, available in bores from Ø 32 to 63, double acting, non magnetic. Heads joined to the barrel through rolling ensure perfect tightening. Supplied with rod nut and head nut.

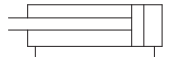

Type RDM Ø 32 ÷ 63 from page 1.11.40



Round cylinders not conforming to standards, available in bores from Ø 32 to 63, double acting, magnetic. Heads joined to the barrel through rolling ensure perfect tightening. Supplied with rod nut and head nut. Possibility of applying one or more magnetic reed switches.

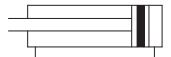

Type RDMA Ø 32 ÷ 63 from page 1.11.60



Round cylinders not conforming to standards, available in bores from Ø 32 to 63, double acting, magnetic, adjustable cushioning. Heads joined to the barrel through rolling ensure perfect tightening. Supplied with rod nut and head nut. Possibility of applying one or more magnetic reed switches.

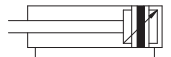

Options		
Description	Symbol	Suffix
Through rod (not available for RS type)		P
Rear spring (available only for RS type)		T
FKM seals	-20°C ÷ +150°C 	V
Low temperature seals	-40°C ÷ +80°C 	BT
Low friction		L
Special male thread (indicate the requested thread. E.g.: R-M 10x1,5; the dimension AM of the special thread will be the same as the standard; cylinder will be supplied without rod nut; for further information please contact the sales department)		R-M..
ATEX versions on request		/ATEX
Special versions on request		/S

The options, when this is possible, can be combined with each other. For options matching see from page 1.11.4; For code key see from page 1.11.5

Options matching

Series	Bore	Model	Standard options matching						
			P	T	V	BT	L	R-M.. ⁽¹⁾	/ATEX
RS	Ø 32 ÷ 63	Standard	-	●	●	●	●	●	●
		Rear spring (T)	-		●	●	●	●	●
		Low friction (L)	-	●	●	●		●	●
RD-RDM	Ø 32 ÷ 63	Standard	●	-	●	●	●	●	●
		Through rod (P)		-	●	●	●	●	●
		Low friction (L)	●	-	●	●		●	●
RDMA	Ø 32 ÷ 63	Standard	●	-	●	●	●	●	●
		Through rod (P)		-	●	●	●	●	●
		Low friction (L)	●	-	●	●		●	●

Key

● matching accessory; - not matching accessory

Options matching - notes

(1) Option **R-M..** require to indicate the desired thread. For further information please contact the sales department.

Standard materials

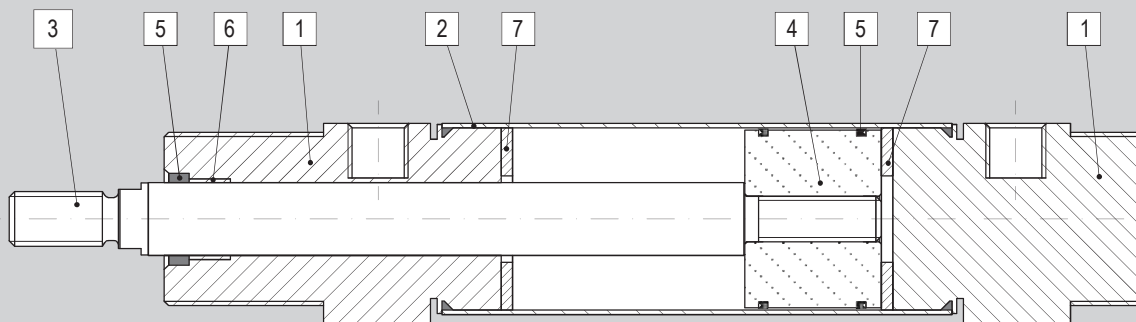

Position	Description	Materials
1	Heads	Anodised aluminium
2	Tube	Stainless Steel AISI 304
3	Rod	Stainless Steel AISI 303
4	Piston	Aluminium
5	Seals	NBR / Polyurethane (PU)
6	Bushing	Self-lubricating sintered bronze
7	Dumper	NBR

Code key

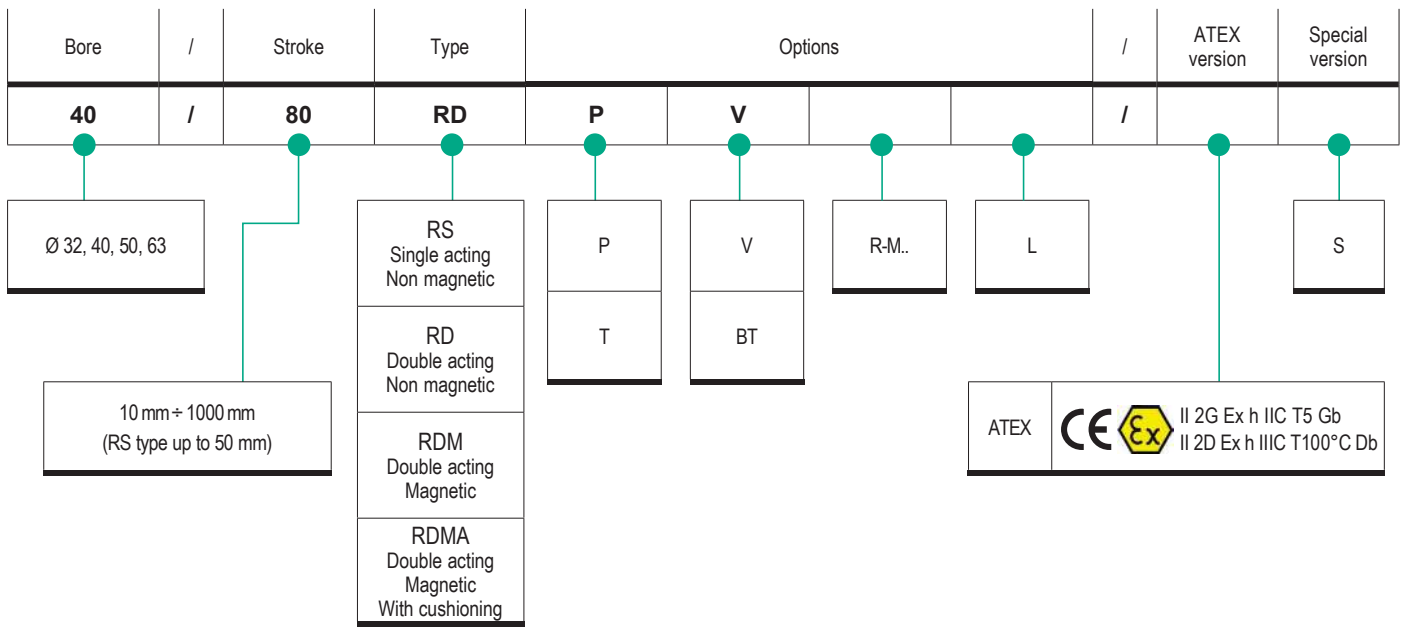

How to order

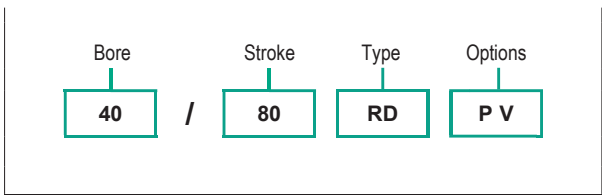

Notes

Options in the same grid are alternative to each others.
 For further information on options and their matching, see page 1.11.3 and 1.11.4
 For further information on the ATEX 2014/34/EU Directive, on classifications and protections, see from page III.1

Accessories

1 - CYLINDERS

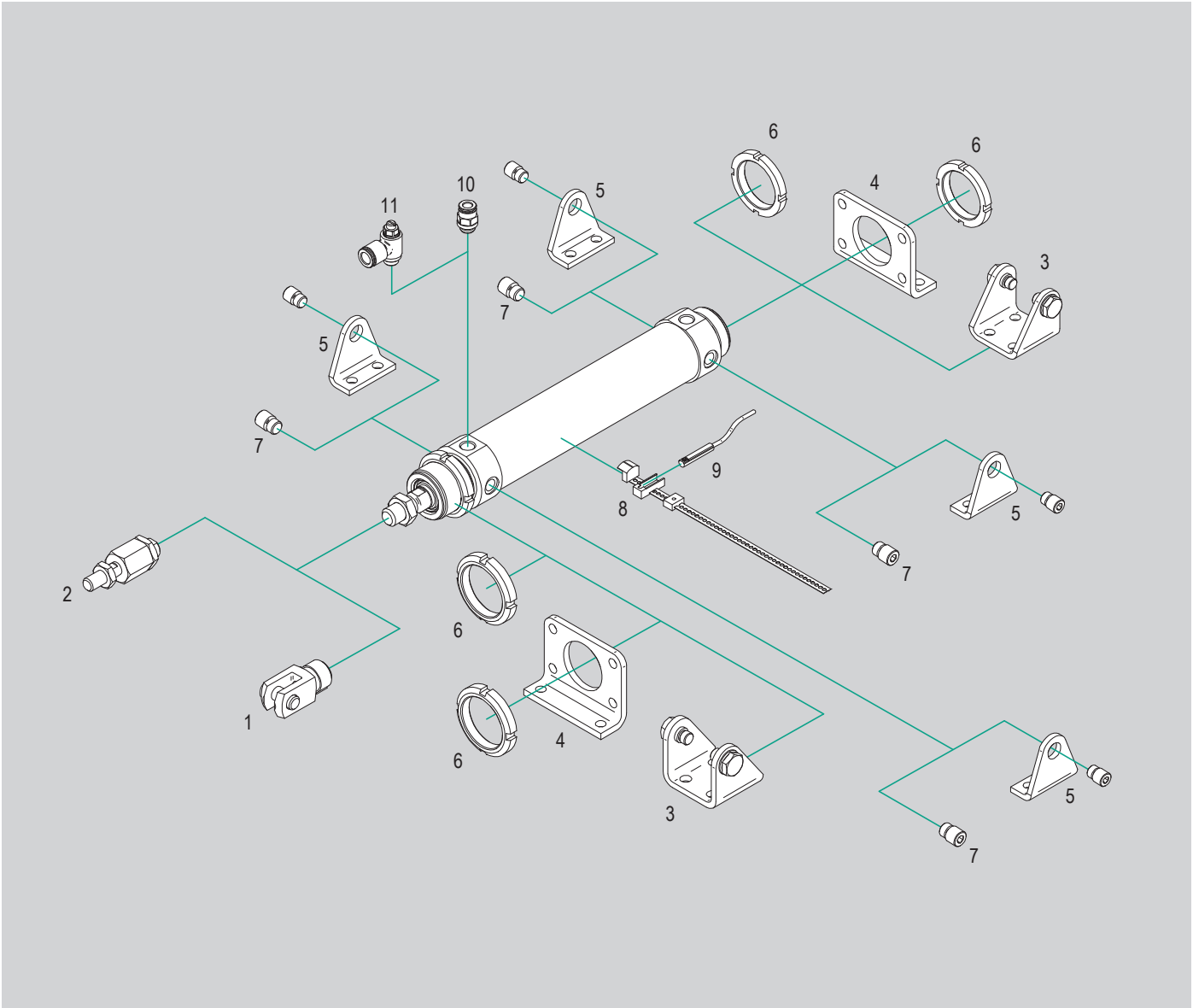

N.	Cylinder bore	Item	Description	Compliance	Matching				Code page	Data sheet page
					RS	RD	RDM	RDMA		
1	Ø 32 ÷ 63	FF..	DIN female clevis with clip	DIN 71752	●	●	●	●	1.11.90	1.86.1
		FFP..	DIN female clevis with pin and seeger		●	●	●	●		1.86.2
		FFN..	DIN female clevis (body only)		●	●	●	●		1.90.10
2	Ø 32 ÷ 63	GB..	Bearing - Self-aligning articulated coupling	-	●	●	●	●	1.96.10	
3	Ø 32 ÷ 63	CF..	Rear clevis	-	●	●	●	●	1.96.11	
4	Ø 32 ÷ 63	P..	Foot-flange	-	●	●	●	●	1.96.12	
5	Ø 32 ÷ 63	CP..	Foot-hinge	-	●	●	●	●	1.120.1	
6	Ø 32 ÷ 63	GH..	Heads nut	-	●	●	●	●	1.110.10	
7	Ø 32 ÷ 63	SEC..	Pins	-	●	●	●	●	1.113.1	
8	Ø 32 ÷ 63	AFR..	Bracket for T type magnetic reed switches	-	-	-	●	●	4.2.1	
9	Ø 32 ÷ 63	ASV..	Magnetic reed switch T groove	2014/34/EU	-	-	●	●	4.94.1	
		MK..	ATEX magnetic reed switch T groove		-	-	●	●		
10	Ø 32 ÷ 63	R..	Push-in fittings	-	●	●	●	●		
11	Ø 32 ÷ 63	V..C	Flow controls, for cylinders	-	●	●	●	●		

Key
 ● matching accessory; - not matching accessory

Round cylinders series R

Series RS



Main features

32 ÷ 63

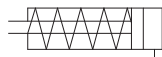

RS

Bores Ø

Single acting
Non magnetic

Type



Technical data

Bore Ø mm	32			40			50			63			
Fluid	Filtered compressed air with or without lubrication. Lubrication, if started, must be continued.												
Pressure range	1 ÷ 10 bar												
Temperature range	-20°C ÷ +80°C (standard)			-20°C ÷ +150°C (V)			-40°C ÷ +80°C (BT)						
Strokes	10 ÷ 50 mm												
Rod thread	M10x1,5			M12x1,75			M16x2						
Thrust force at 6 bar (N)	482			754			1178			1869			
Traction force (N)	Stroke (mm)	10	25	50	10	25	50	10	25	50	10	25	50
	min.	57	51	40	98	86	64	147	130	101	147	130	101
	max.	62	62	62	105	105	105	158	158	158	158	158	158

Standard strokes

Stroke mm	RS Bore Ø mm			
	32	40	50	63
10				
25				
50				

Key

■ Standard stroke

Standard dimensions

1 - CYLINDERS

Type: RS

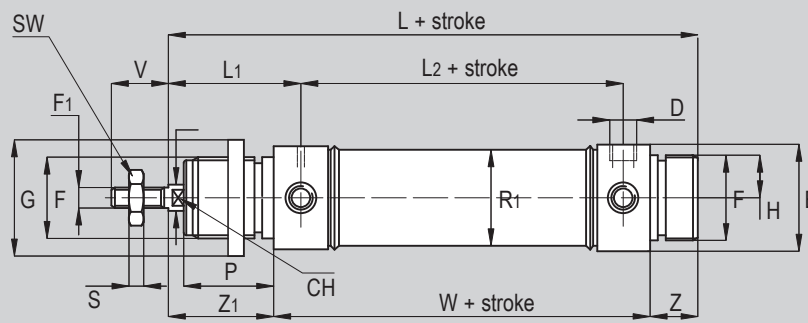

∅ (mm)	V	F	P	D	F ₁	R	L ₂	Z	Z ₁	W	L ₁	L	R ₁	H	S	∅B	CH	SW	∅G
32	20	M30x1,5	30	1/8"	M10x1,5	12	78	14	38	96	47	148	33,6	17,5	6	38	10	17	45
40	24	M38x1,5	35	1/4"	M12x1,75	16	89	16	45	113	57	174	41,6	21	7	46	13	19	50
50	32	M45x1,5	38	1/4"	M16x2	20	96	18	50	120	62	188	52,4	26,5	8	57	17	24	58
63	32	M45x1,5	38	3/8"	M16x2	20	98	18	50	124	63	192	65,4	32,5	8	70	17	24	58

Round cylinders series R

Series RD - RDM



Main features

32 ÷ 63

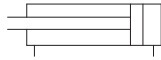

RD

Bores Ø

Double acting
Non magnetic

Type

32 ÷ 63

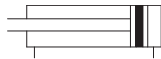

RDM

Bores Ø

Double acting
Magnetic

Type



Technical data

Bore Ø mm	32	40	50	63
Fluid	Filtered compressed air with or without lubrication. Lubrication, if started, must be continued.			
Pressure range	1 ÷ 10 bar			
Temperature range	-20°C ÷ +80°C (standard)	-20°C ÷ +150°C (V)	-40°C ÷ +80°C (BT)	
Standard strokes	10 ÷ 1000 mm			
Rod thread	M10x1,5	M12x1,75	M16x2	

Standard strokes

Stroke mm	RD Bore Ø mm			
	32	40	50	63
10				
25				
50				
80				
100				
125				
160				
200				
250				
320				
400				
500				

Stroke mm	RDM Bore Ø mm			
	32	40	50	63
10				
25				
50				
80				
100				
125				
160				
200				
250				
320				
400				
500				

Key
 Standard stroke

Standard dimensions

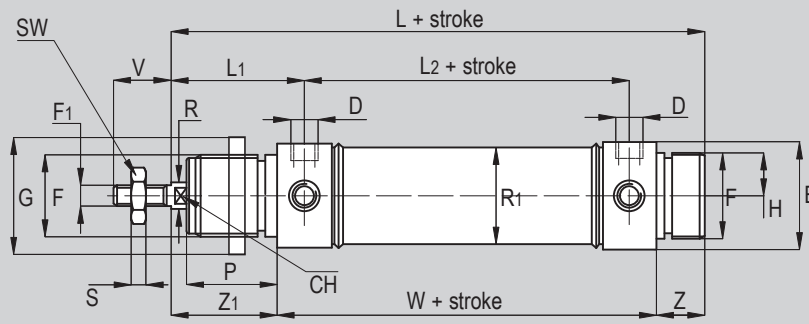

Type: RD - RDM

Ø (mm)	V	F	P	D	F ₁	R	L ₂	Z	Z ₁	W	L ₁	L	R ₁	H	S	ØB	CH	SW	ØG
32	20	M30x1,5	30	G1/8"	M10x1,5	12	78	14	38	96	47	148	33,6	17,5	6	38	10	17	45
40	24	M38x1,5	35	G1/4"	M12x1,75	16	89	16	45	113	57	174	41,6	21	7	46	13	19	50
50	32	M45x1,5	38	G1/4"	M16x2	20	96	18	50	120	62	188	52,4	26,5	8	57	17	24	58
63	32	M45x1,5	38	G3/8"	M16x2	20	98	18	50	124	63	192	65,4	32,5	8	70	17	24	58

Dimensions with options

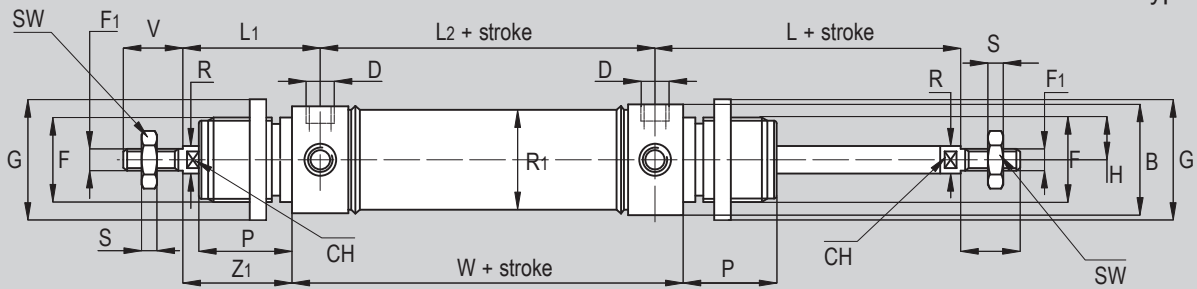

Type: ...P

Ø (mm)	V	F	P	D	F ₁	R	L ₂	Z ₁	W	L	L ₁	R ₁	H	S	ØB	CH	SW	ØG
32	20	M30x1,5	30	G1/8"	M10x1,5	12	78	38	96	47	47	33,6	17,5	6	38	10	17	45
40	24	M38x1,5	35	G1/4"	M12x1,75	16	89	45	113	57	57	41,6	21	7	46	13	19	50
50	32	M45x1,5	38	G1/4"	M16x2	20	96	50	120	62	62	52,4	26,5	8	57	17	24	58
63	32	M45x1,5	38	G3/8"	M16x2	20	98	50	124	63	63	65,4	32,5	8	70	17	24	58

Round cylinders series R
Series RDMA



Main features

32 ÷ 63

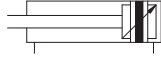

RDMA

Bores Ø

Double acting
Magnetic
With cushioning

Type



Technical data

Bore Ø mm	32	40	50	63
Fluid	Filtered compressed air with or without lubrication. Lubrication, if started, must be continued.			
Pressure range	1 ÷ 10 bar			
Temperature range	-20°C ÷ +80°C (standard)	-20°C ÷ +150°C (V)	-40°C ÷ +80°C (BT)	
Strokes	25 ÷ 1000 mm			
Rod thread	M10x1,5	M12x1,75	M16x2	

Standard strokes

Stroke mm	RDMA Bore Ø mm			
	32	40	50	63
25				
50				
80				
100				
125				
160				
200				
250				
320				
400				
500				

Key
 Standard stroke

Standard dimensions

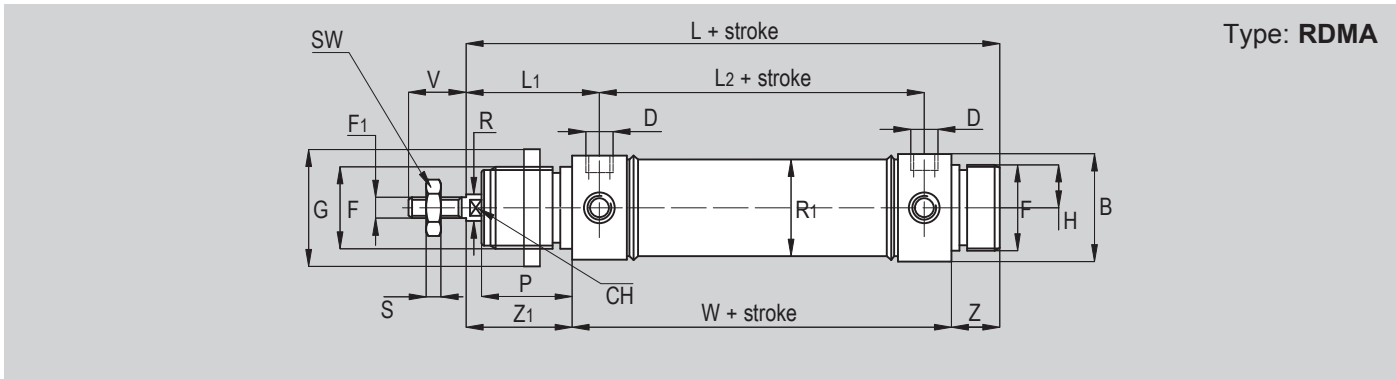

Type: **RDMA**

Ø (mm)	V	F	P	D	F ₁	R	L ₂	Z	Z ₁	W	L ₁	L	R ₁	H	S	ØB	CH	SW
32	20	M30x1,5	30	G1/8"	M10x1,5	12	78	14	38	96	47	148	33,6	17,5	6	38	10	17
40	24	M38x1,5	35	G1/4"	M12x1,75	16	89	16	45	113	57	174	41,6	21	7	46	13	19
50	32	M45x1,5	38	G1/4"	M16x2	20	96	18	50	120	62	188	52,4	26,5	8	57	17	24
63	32	M45x1,5	38	G3/8"	M16x2	20	98	18	50	124	63	192	65,4	32,5	8	70	17	24

Dimensions with options

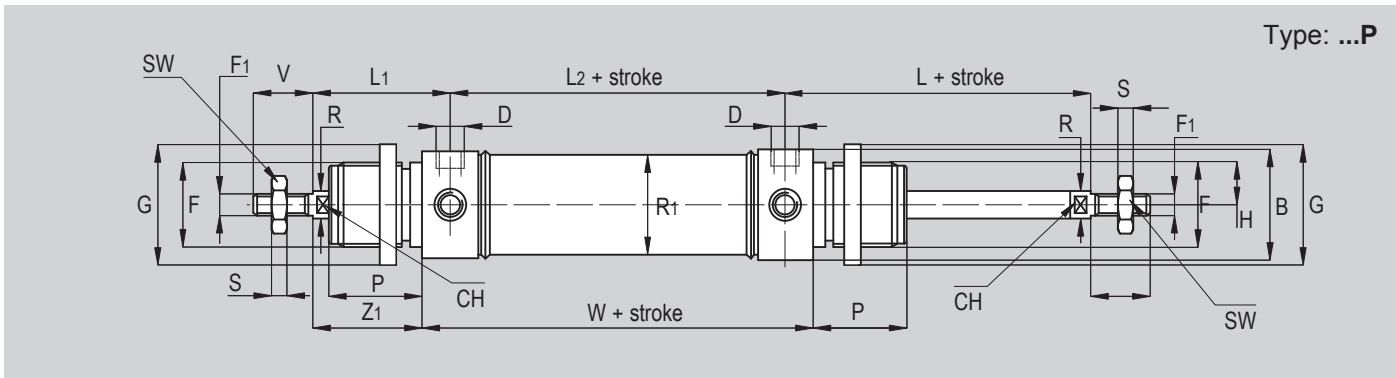

Type: **...P**

Ø (mm)	V	F	P	D	F ₁	R	L ₂	Z ₁	W	L	L ₁	R ₁	H	S	ØB	CH	SW	ØG
32	20	M30x1,5	30	G1/8"	M10x1,5	12	78	38	96	47	47	33,6	17,5	6	38	10	17	45
40	24	M38x1,5	35	G1/4"	M12x1,75	16	89	45	113	57	57	41,6	21	7	46	13	19	50
50	32	M45x1,5	38	G1/4"	M16x2	20	96	50	120	62	62	52,4	26,5	8	57	17	24	58
63	32	M45x1,5	38	G3/8"	M16x2	20	98	50	124	63	63	65,4	32,5	8	70	17	24	58

Female clevis with clip FF..DIN

	For cylinder Ø mm	Code	Item	Compliance
	32	041025	FF10DIN	
	40	041026	FF12DIN	
	50	041028	FF16DIN	
	63			

Female clevis with pin and seeger FFP..DIN

	For cylinder Ø mm	Code	Item	Compliance
	32	041096	FFP10DIN	
	40	041217	FFP12DIN	
	50	041213	FFP16DIN	
	63			

Female clevis (body only) FFN..DIN

	For cylinder Ø mm	Code	Item	Compliance
	32	041020	FFN10DIN	
	40	041203	FFN12DIN	
	50	041202	FFN16DIN	
	63			

Self-aligning articulated coupling GB..

	For cylinder Ø mm	Code	Item	Compliance
	32	041705	GB050	-
	40	041707	GB090	

Rear clevis in steel with pins CF..AQM+P

	For cylinder Ø mm	Code	Item	Compliance
	32	040058	CF032AQM+P	-
	40	040059	CF040AQM+P	
	50	040060	CF050AQM+P	
	63	040061	CF063AQM+P	

Kit composed by one clevis and two pins.

Foot-flange in steel P..AQM

	For cylinder Ø mm	Code	Item	Compliance
	32	040054	P032AQM	-
	40	040055	P040AQM	
	50	040056	P050AQM	
	63	040057	P063AQM	

For mounting on cylinder require heads nut GH..AQM, see below.

Foot-hinge in steel with pin CP..AQM+P

	For cylinder Ø mm	Code	Item	Compliance
	32	040170	CP032AQM+P	-
	40	040171	CP040AQM+P	
	50	040172	CP050AQM+P	
	63	040173	CP063AQM+P	

Kit composed by two foot-hinge supplied with pins.

Pin in steel SEC..AQM



	For cylinder Ø mm	Code	Item	Compliance
	32	040062	SEC032AQM	-
	40	040063	SEC040AQM	
	50	040064	SEC050AQM	
	63	040065	SEC063AQM	

Kit composed by two pins.

Head nuts in steel GH..AQM



	For cylinder Ø mm	Code	Item	Compliance
	32	040066	GH032AQM	-
	40	040067	GH040AQM	
	50-63	040068	GH050/063AQM	

Magnetic reed switch T groove ASV..

	For cylinder Ø mm	Code	Item	Cylinder matching
	32 ÷ 63	070946 	ASV1C525	RDM* RDMA*
		071863	ASV1C550	
		071864	ASV1C51K	
		071189	ASV1C5M8	
		073639	ASV4D225	
		070246 	ASV4D2M8	
		074900	ASV7N225	
		070247	ASV7N2M8	
		070372	ASV7M2M8	
		072918	ASV1H525	

*With bracket type AFR1063 for magnetic reed switches T groove

ATEX magnetic reed switch T groove MK..

	For cylinder Ø mm	Code	Item	Compliance	Cylinder matching
	32 ÷ 63	071120	MK500A		RDM* RDMA*
		071108	MK502A		

*With bracket type AFR1063 for magnetic reed switches T groove

Bracket AFR.. for magnetic reed switches T groove

	For cylinder Ø mm	Code	Item	Compliance
	32 ÷ 63	072907	AFR1063	-

CNOMO

Cylinders



Find out our
key products



Solution for most applications



Easy and intuitive choice



Excellent value for money



Wide availability



Fast delivery



Features and certifications

Series of cylinders conforming to CNOMO standards. With round barrel and tie rods, available in bores from Ø 25 to 200, double acting, with adjustable cushionings at both ends, magnetic or non magnetic. Supplied as standard in compliance with Reach and RoHS directives, and SIL certificated. On request, they can be also supplied according to the 2014/34/EU ATEX Directive.



Type CX Ø 32 ÷ 100 from page 1.14.20



Cylinders CNOMO, available in bores from Ø 32 to 100, double acting, with adjustable cushionings at both ends, non magnetic. Supplied with rod nut.

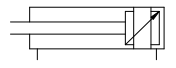

Type CM Ø 25 ÷ 200 from page 1.14.40



Cylinders CNOMO, available in bores from Ø 32 to 200, double acting, with adjustable cushionings at both ends, magnetic. Supplied with rod nut.

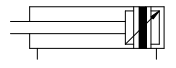

Options		
Description	Symbol	Suffix
Through rod		P
Stainless Steel AISI 304 rod		K
Stainless Steel AISI 316 rod		K316
Stainless Steel tie-rods, nuts and grower		K1
FKM seals	-20°C ÷ +150°C	V
FKM rod seal	-20°C ÷ +80°C	V1
Tandem forward movement piston rods coupled together		TA1
Tandem forward movement piston rods independent		TA2
Tandem back to back		TA3
Tandem front to front		TA4
Special length of front tie rod (indicate the requested length in mm, E.g.: T1=25; the thread will remain standard; for further information please contact the sales department)		T1
Special length of rear tie rod (indicate the requested length in mm, E.g.: T2=25; the thread will remain standard; for further information please contact the sales department)		T2
Without adjustable cushionings		D
Adjustable rear cushioning only		D1
Adjustable front cushioning only		D2
Stainless Steel AISI 316L tube		TX
ATEX versions on request (only with options K or K316; for further information please contact the sales department)		/ATEX
Special versions on request		/S

The options, when this is possible, can be combined with each other. For options matching see from page 1.14.4; For code key see from page 1.14.5

Options matching

Series	Bore	Model	Standard options matching												
			P	K	K316	K1	V	V1	TA..	T.. ⁽¹⁾	D	D1	D2	TX	/ATEX ⁽²⁾
CX	Ø 32 ÷ 100	Standard	●	●	●	●	●	●	●	●	●	●	●	●	●
		Through rod (P)		●	●	●	●	●	-	●	●	●	●	●	●
		Stainless Steel rod (K)	●		-	●	●	●	●	●	●	●	●	●	●
CM	Ø 25 ÷ 200	Standard	●	●	●	●	●	●	●	●	●	●	●	●	●
		Through rod (P)		●	●	●	●	●	-	●	●	●	●	●	●
		Stainless Steel rod (K)	●		-	●	●	●	●	●	●	●	●	●	●

Key

● allowed matching; - not allowed matching

Options matching - notes

(1) Options **T1** or **T2** require to indicate the desired dimension in mm (E.G. "T1=25"). Furthermore, please note that the thread of tie rods will remain standard. For further information please contact the sales department.

(2) In the **/ATEX** versions, is required to mount the stainless steel rod (options **K** or **K316**).

Standard materials

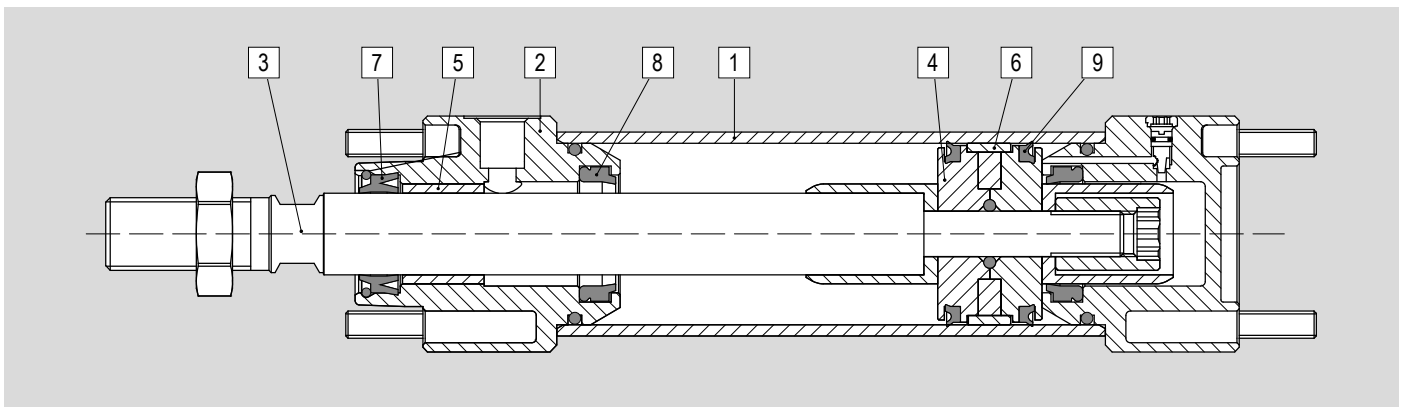

Position	Description	Materials	
		CX..	CM..
1	Tube	Anodised aluminium	
2	Heads	Die-cast aluminium powder coated	
3	Rod	Chrome-plated C45 steel	
4	Piston	Monobloc	Aluminium
5	Bushing	Self-lubricating sintered bronze	
6	Guide ring	-	Acetalic resin (POM)
7	Rod seal	NBR with metal core	
8	Cushioning seal	Polyurethane (PU)	
9	Piston seal	Polyurethane (PU)	
-	Other seals	NBR	

Code key

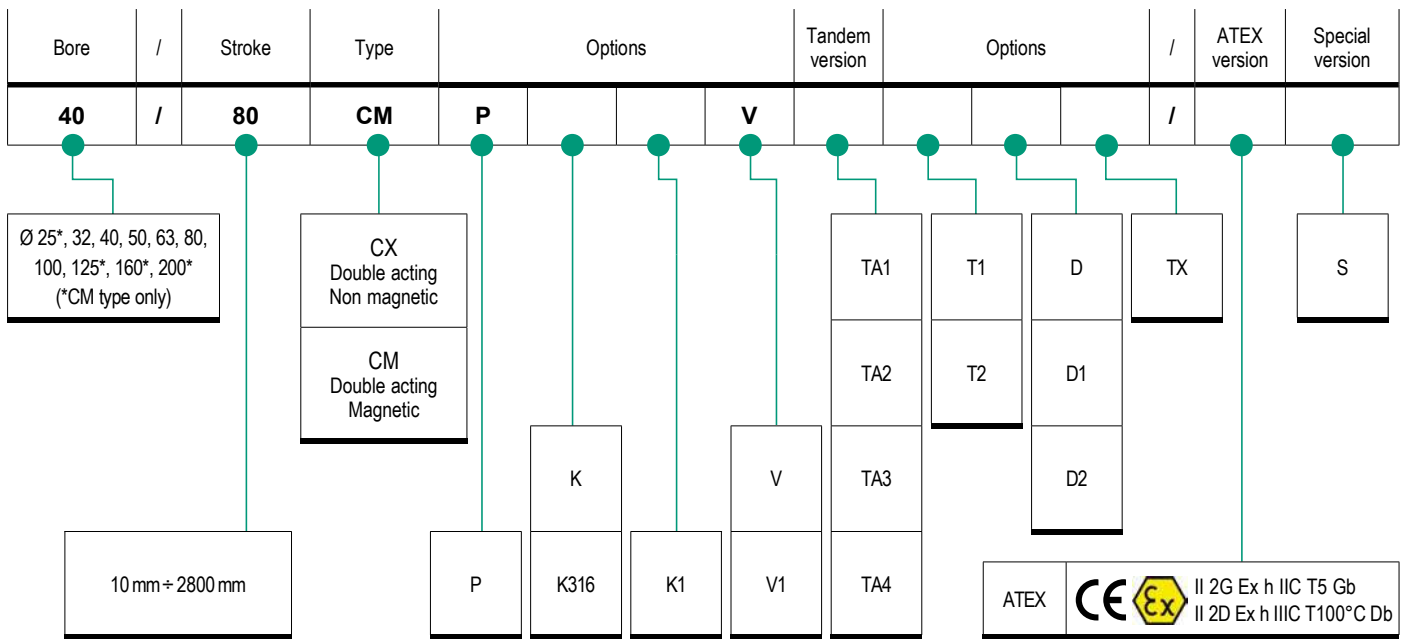

How to order

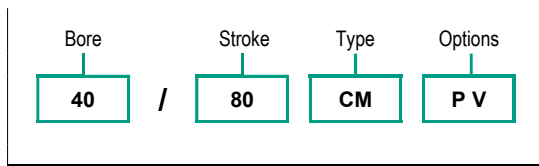

Notes

Options in the same grid are alternative to each others.
 For further information on options and their matching, see page 1.14.3 and page 1.14.4
 For further information on the ATEX 2014/34/EU Directive, on classifications and protections, see from page III.1

Standard** seal kit for CM type

Number of components	Description
n. 1	Rod seal
n. 2	Cushioning seal
n. 2	Piston seal
n. 2	Tube-head o-ring
n. 1	Seeger ring
n. 1	Piston guiding ring
n. 1	Sempiston o-ring
n. 2	Cushioning screw o-ring

Standard seal kit code key

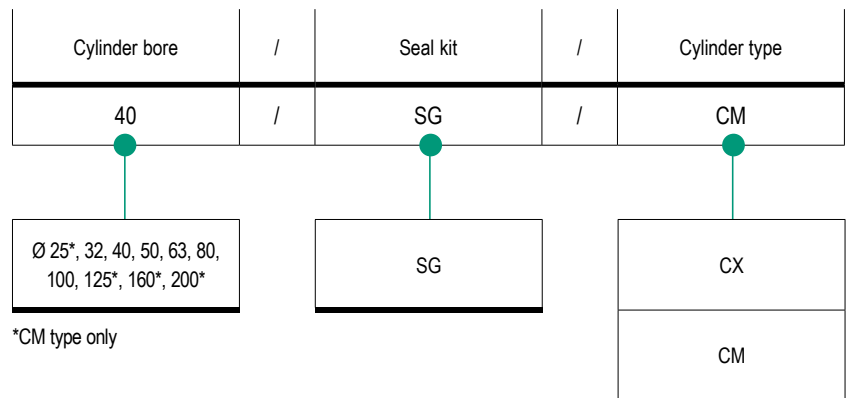

Standard** seal kit for CX type

Number of components	Description
n. 1	Rod seal
n. 2	Cushioning seal
n. 1	Piston monobloc
n. 1	Seeger ring
n. 2	Tube-head o-ring
n. 2	Cushioning screw o-ring

**For cylinders with options P, V or V1, the kit include further components.

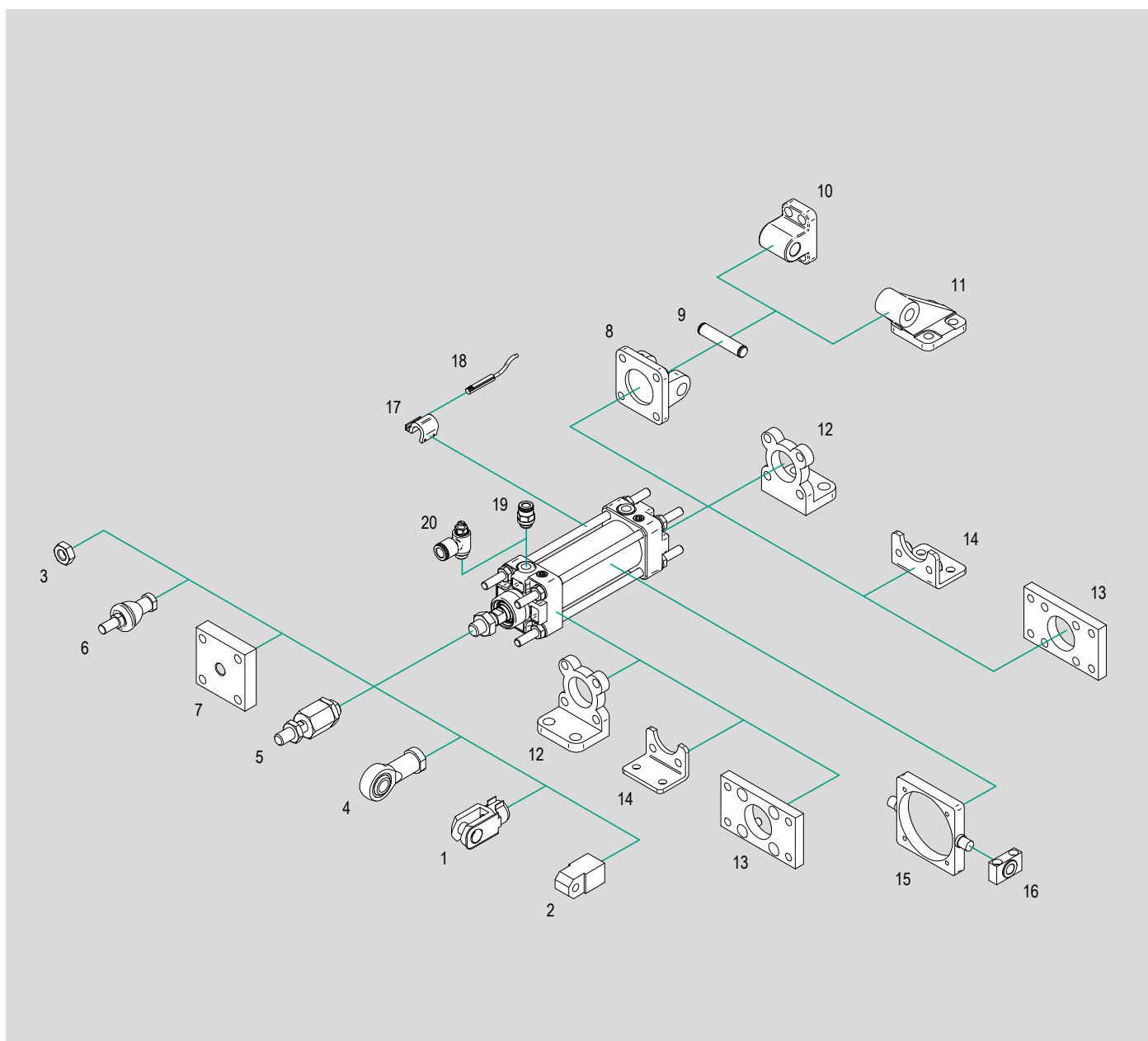

N.	Cylinder bore	Item	Description	Compliance	Matching		Code page	Data sheet page	
					CX	CM			
1	Ø 25 ÷ 125	FF..CN	CNOMO female clevis with clip	-	●	●	1.14.90	1.87.1	
	Ø 25 ÷ 200	FFP..CN	CNOMO female clevis with pin and seeger		●	●			
		FFN..CN	CNOMO female clevis (body only)		●	●			
2	Ø 25 ÷ 200	FM..CN	CNOMO male clevis with pin and seeger	-	●	●	1.14.90	1.87.2	
		FMN..CN	CNOMO male clevis (body only)		●	●			
3	Ø 25 ÷ 200	D..	Rod nut	UNI 5589	●	●	1.14.90	1.90.70	
4	Ø 25 ÷ 200	RF..SE	Bearing head (DIN 648K) with female thread	ISO 8139	●	●		1.90.1	
5	Ø 25 ÷ 200	GB..	Bearing - Self-aligning articulated coupling	-	●	●		1.90.10	
6	Ø 25 ÷ 100	RBI..	Bearing - Axial articulated coupling	ISO	●	●		1.90.20	
	Ø 40 ÷ 125	RBL..	Bearing - Angular articulated coupling		●	●		1.90.30	
7	Ø 50 ÷ 200	GC..	Self-aligning coupling	-	●	●	1.90.40		
8	Ø 32 ÷ 200	CF..ALCN	Rear clevis	CNOMO	●	●	1.14.91	1.99.1	
9	Ø 32 ÷ 200	SEC..AQC�	Pin for rear clevis		●	●	1.14.92	1.99.51	
10	Ø 32 ÷ 200	AN..ALCN	Rear standard hinge		●	●	1.14.90	1.99.1	
11	Ø 32 ÷ 200	AS..ALCN	Rear 90° hinge		●	●	1.14.91	1.99.2	
13	Ø 32 ÷ 200	P..ALCN	High foot		●	●		1.99.50	
		FL..AQC�	Counterbored flange		●	●			
14	Ø 32 ÷ 200	FLF..AQC�	Threaded flange		●	●	1.14.92	1.99.51	
		PB..AQC�	Low foot		●	●			
15	Ø 32 ÷ 200	CT..AQC�	Adjustable center trunnion		●	●	1.14.92	1.99.52	
		CTN..AQC�	Non adjustable center trunnion		●	●			
16	Ø 32 ÷ 200	ST..AQIS	Support for center trunnion		ISO AT4	●	●	1.99.53	
17	Ø 25 ÷ 200	AS..	Bracket for T type magnetic reed switches		-	-	●	1.14.91	1.120.3
			Bracket for hi-temp. magnetic reed switches			-	●		1.120.4
18	Ø 25 ÷ 200	ASV..	Magnetic reed switch T groove	2014/34/EU	-	●	1.14.92	1.110.10	
		MK..	ATEX magnetic reed switch T groove		-	●		1.113.1	
		ASH..	Hi-temperatures magnetic reed switch		-	●		1.111.1	
19	Ø 25 ÷ 200	R..	Push-in fittings	-	●	●	4.2.1		
20	Ø 25 ÷ 200	V..C	Flow controls, for cylinders	-	●	●	4.94.1		

Key

● matching accessory; - not matching accessory

Main features

32 ÷ 100

Bores Ø

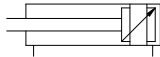

Double acting
Non magnetic
With cushioning

CX

Type



Technical data

Bore Ø mm	32	40	50	63	80	100	
Fluid	Filtered compressed air with or without lubrication. Lubrication, if started, must be continued.						
Pressure range	1 ÷ 10 bar						
Temperature range	-20°C ÷ +80°C (standard / V1)		-20°C ÷ +150°C (V)				
Strokes	10 ÷ 2800 mm						
Cushion length	21	28	28	34	34	38	
Port	1/8"	1/4"		3/8"		1/2"	
Rod thread	M10x1,5	M16x1,5		M20x1,5		M27x2	
Weight (g.)	Stroke zero	453	842	1231	1962	2867	4772
	Additional 10 mm	24	35	50	60	76	107

Standard strokes

Stroke mm	CX Bore Ø mm					
	32	40	50	63	80	100
10						
25						
50						
80						
100						
125						
150						
160						
200						
250						
300						
320						
400						
450						
500						

Key
 Standard stroke

Standard dimensions

Type: **CX**

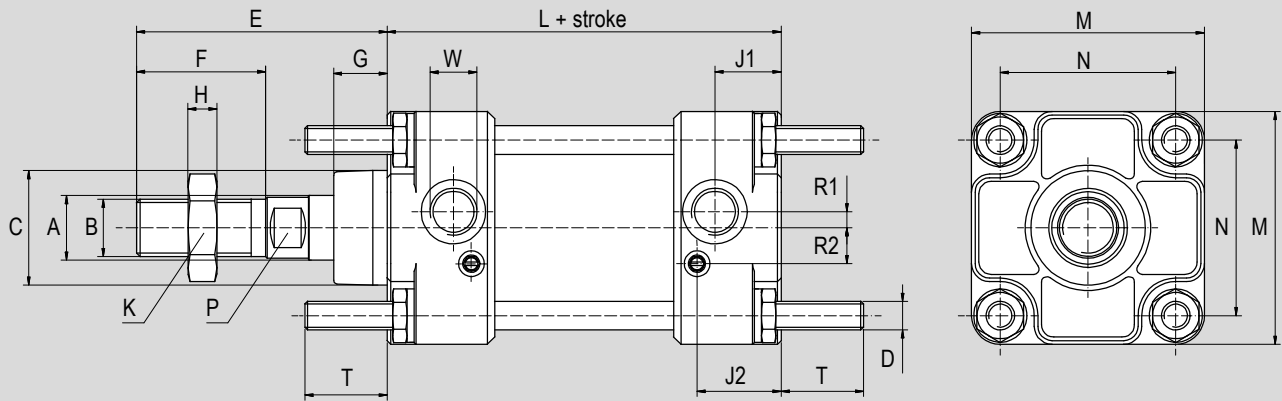

1 - CYLINDERS

Ø (mm)	ØA f7	B	ØC e9	E	F	G	L ±1	P	K	H	D	T*	W	M	N	J1	J2	R1	R2
32	12	M10x1.5	25	45	20	15	80	8	17	6	M6	17	1/8"	45	33	15	16.5	6	8
40	18	M16x1.5	32	70	36	15	110	13	24	8	M6	17	1/4"	52	40	17.5	23	3	11
50	18	M16x1.5	32	70	36	15	110	13	24	8	M8	23	1/4"	65	49	18.5	23.5	4.5	10
63	22	M20x1.5	45	85	46	20	125	17	30	9	M8	23	3/8"	75	59	19	23	4.5	14
80	22	M20x1.5	45	85	46	20	125	17	30	9	M10	28	3/8"	95	75	22	25	8	13
100	30	M27x2	55	110	63	20	145	22	41	12	M10	28	1/2"	115	90	26	31	12	10

*In case of combination with center trunnion (CT..AQC or CTN..AQC, see page 1.14.92), T dimension is equal 0 in every bore; In case of combination with threaded flange (FLF..AQC, see page 1.14.91), T dimension of tie-rods is 1 mm lower of the flange thickness (AS dimension, see page 1.99.50), while on the opposite side, T dimension is equal 0. These accessories necessarily have to be ordered with the cylinder.

Dimensions with options

Type: **...P**

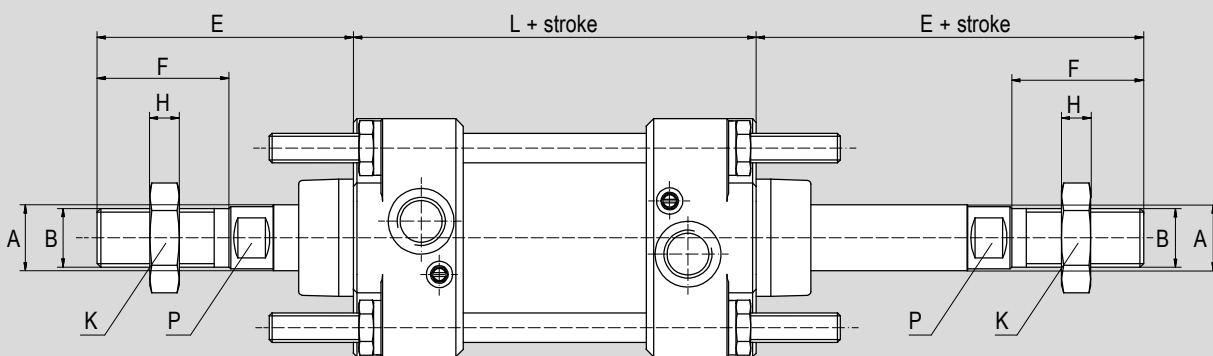

Ø (mm)	ØA f7	B	E	F	L ±1	P	K	H
32	12	M10x1.5	45	20	90	8	17	6
40	18	M16x1.5	70	36	129	13	24	8
50	18	M16x1.5	70	36	129	13	24	8
63	22	M20x1.5	85	46	143	17	30	9
80	22	M20x1.5	85	46	143	17	30	9
100	30	M27x2	110	63	164	22	41	12

Dimensions tandem versions

1 - CYLINDERS

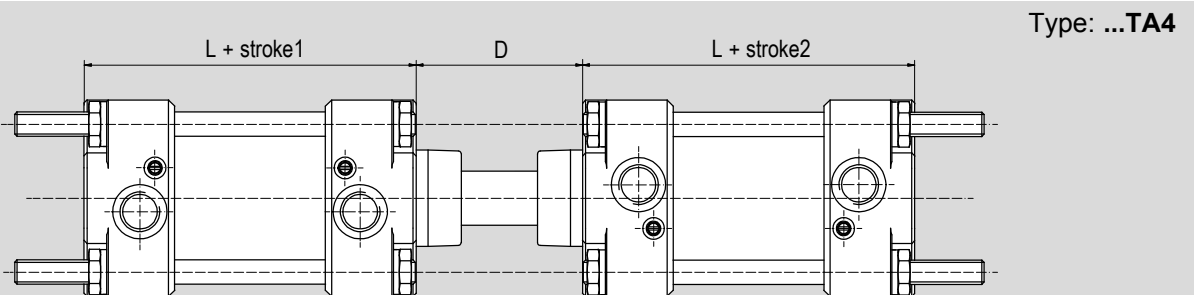
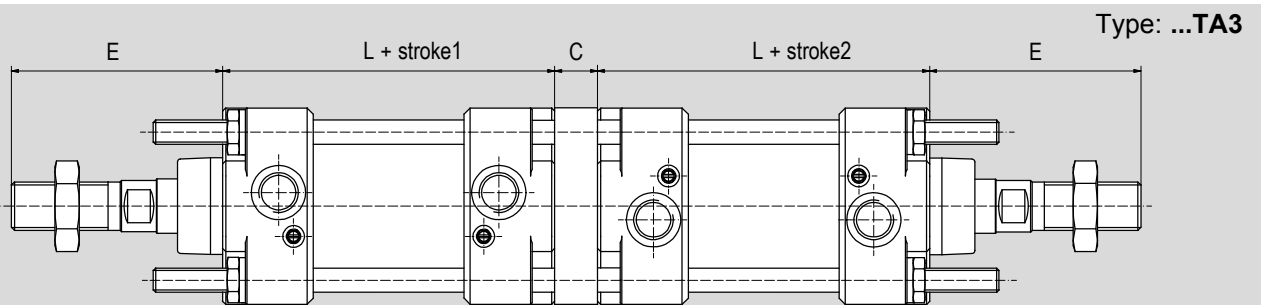
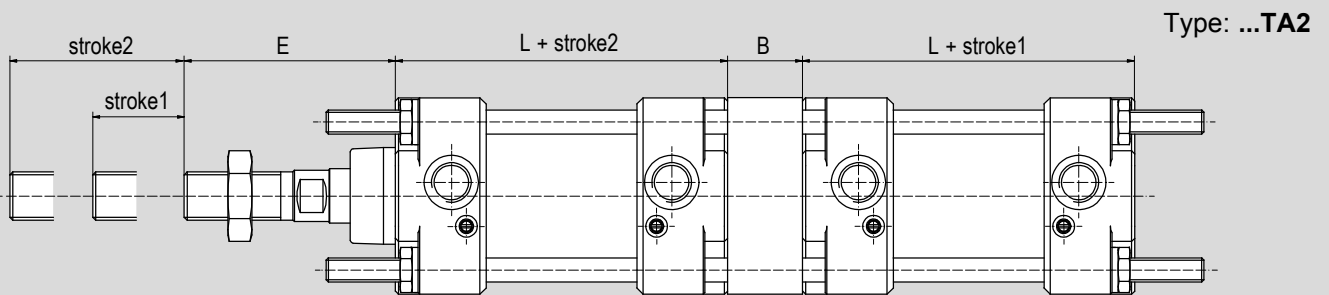
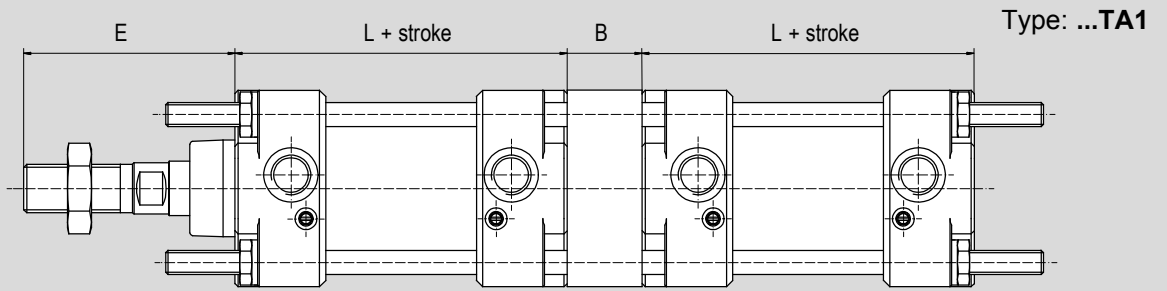

∅ mm	E	L	B	C	D
32	45	80	30	5	38
40	70	110	30	8	40
50	70	110	30	8	47
63	85	125	40	10	59
80	85	125	40	10	62
100	110	145	40	15	55

Main features

25 ÷ 200

Bores Ø

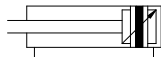

Double acting
Magnetic
With cushioning

CM

Type



Technical data

Bore Ø mm	25	32	40	50	63	80	100	125	160	200	
Fluid	Filtered compressed air with or without lubrication. Lubrication, if started, must be continued.										
Pressure range	1 ÷ 10 bar										
Temperature range	-20°C ÷ +80°C (standard / V1)					-20°C ÷ +150°C (V)					
Strokes	10 ÷ 2800 mm										
Cushion length	21		28		34		38	27	40		
Port	1/8"		1/4"		3/8"		1/2"		3/4"		
Rod thread	M10x1,5		M16x1,5		M20x1,5		M27x2		M36x2		
Weight (g.)	Stroke zero	377	453	842	1231	1962	2867	4772	6146	12846	16175
	Additional 10 mm	22	24	35	50	60	76	107	135	232	249

Standard strokes

Stroke mm	CM Bore Ø mm									
	25	32	40	50	63	80	100	125	160	200
10										
25										
50										
80										
100										
125										
150										
160										
200										
250										
300										
320										
400										
450										
500										

Key
 Standard stroke

Standard dimensions

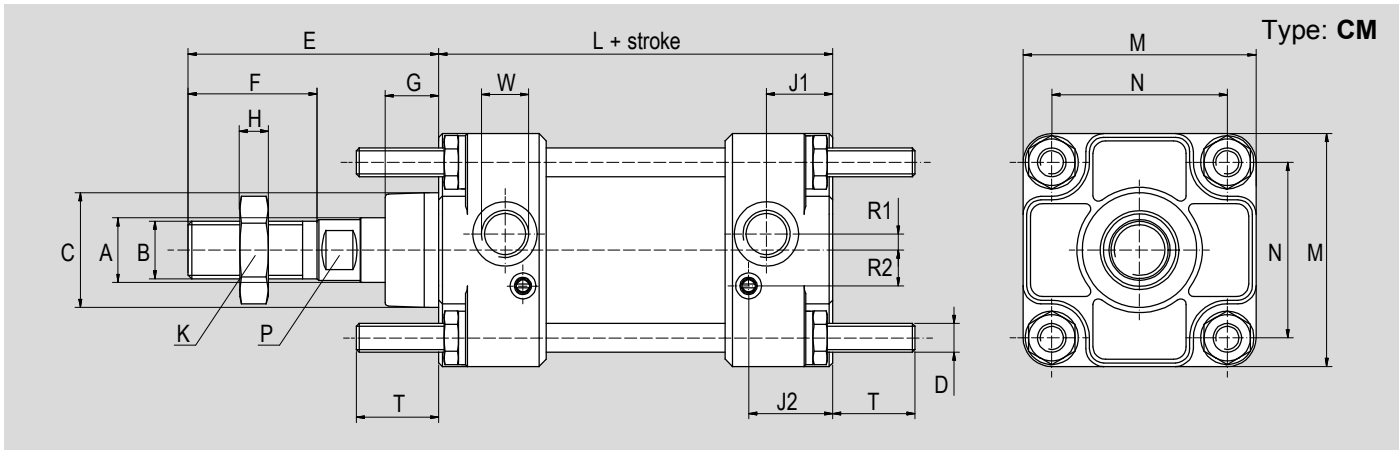

Ø (mm)	ØA f7	B	ØC e9	E	F	G	L ±1	P	K	H	D	T*	W	M	N	J1	J2	R1	R2
25	12	M10x1.5	25	45	20	15	80	8	17	6	M6	17	1/8"	40	28	7	11	0.75	7.5
32	12	M10x1.5	25	45	20	15	80	8	17	6	M6	17	1/8"	45	33	15	16.5	6	8
40	18	M16x1.5	32	70	36	15	110	13	24	8	M6	17	1/4"	52	40	17.5	23	3	11
50	18	M16x1.5	32	70	36	15	110	13	24	8	M8	23	1/4"	65	49	18.5	23.5	4.5	10
63	22	M20x1.5	45	85	46	20	125	17	30	9	M8	23	3/8"	75	59	19	23	4.5	14
80	22	M20x1.5	45	85	46	20	125	17	30	9	M10	28	3/8"	95	75	22	25	8	13
100	30	M27x2	55	110	63	20	145	22	41	12	M10	28	1/2"	115	90	26	31	12	10
125	30	M27x2	55	110	63	20	145	22	41	12	M12	34	1/2"	140	110	-	-	-	-
160	40	M36x2	65	135	85	25	180	32	54	14	M16	42	3/4"	180	140	-	-	-	-
200	40	M36x2	65	135	85	25	180	32	54	14	M16	42	3/4"	220	175	-	-	-	-

*In case of combination with center trunnion (CT..AQC or CTN..AQC, see page 1.14.92), T dimension is equal 0 in every bore; In case of combination with threaded flange (FLF..AQC, see page 1.14.91), T dimension of tie-rods is 1 mm lower of the flange thickness (AS dimension, see page 1.99.50), while on the opposite side, T dimension is equal 0. These accessories necessarily have to be ordered with the cylinder.

Dimensions with options

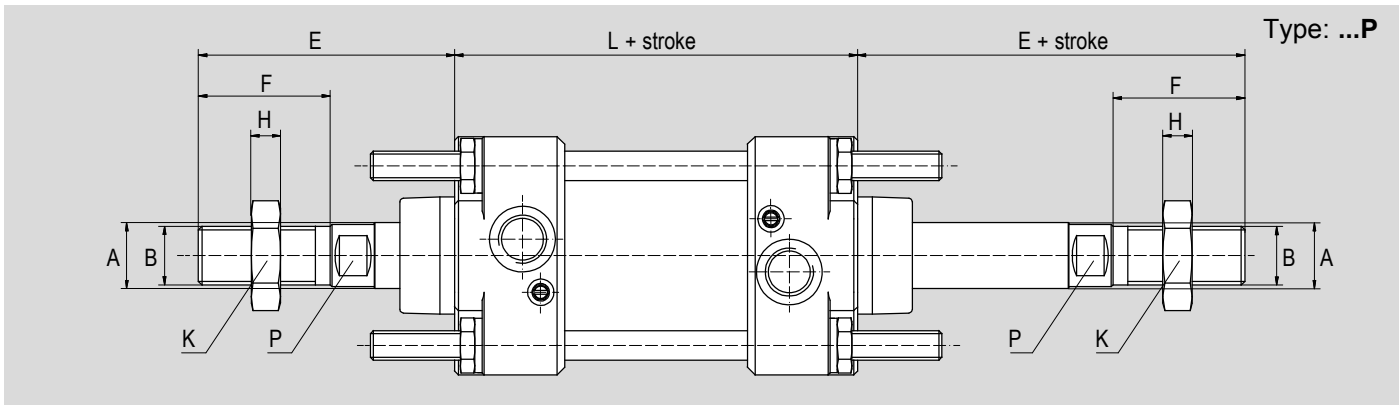

Ø (mm)	ØA f7	B	E	F	L ±1	P	K	H
25	12	M10x1.5	45	20	90	8	17	6
32	12	M10x1.5	45	20	90	8	17	6
40	18	M16x1.5	70	36	129	13	24	8
50	18	M16x1.5	70	36	129	13	24	8
63	22	M20x1.5	85	46	143	17	30	9
80	22	M20x1.5	85	46	143	17	30	9
100	30	M27x2	110	63	164	22	41	12
125	30	M27x2	110	63	164	22	41	12
160	40	M36x2	135	85	200	32	54	14
200	40	M36x2	135	85	200	32	54	14

Dimensions tandem versions

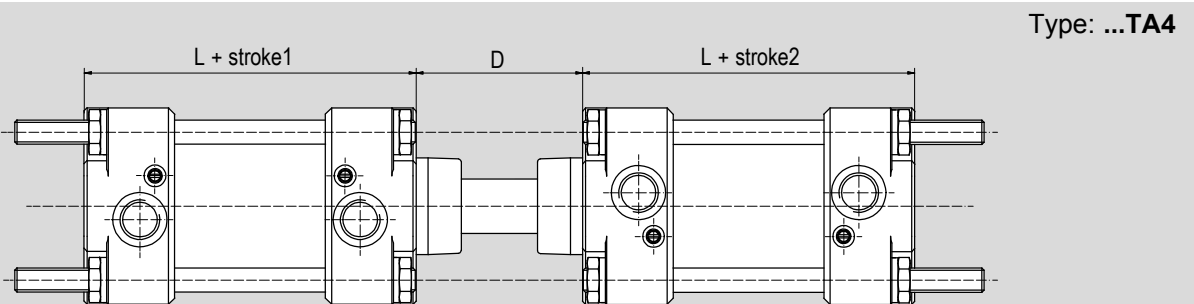
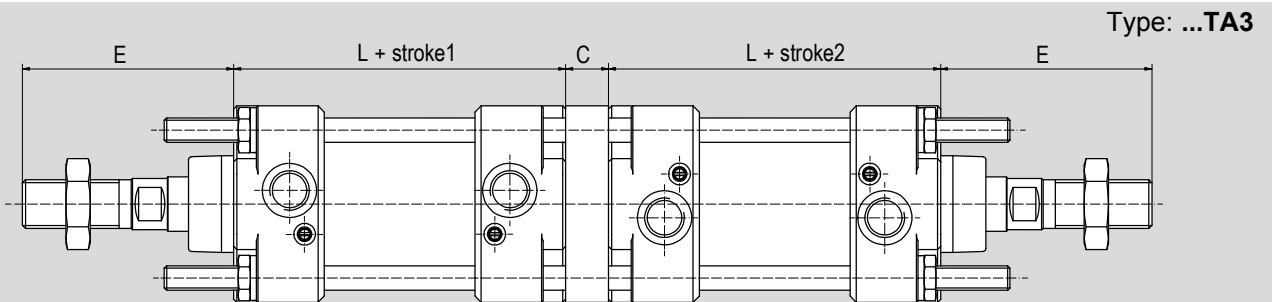
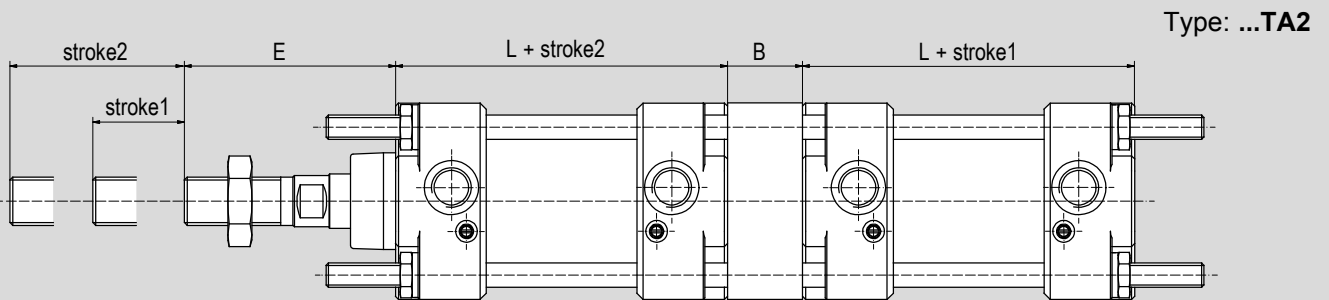
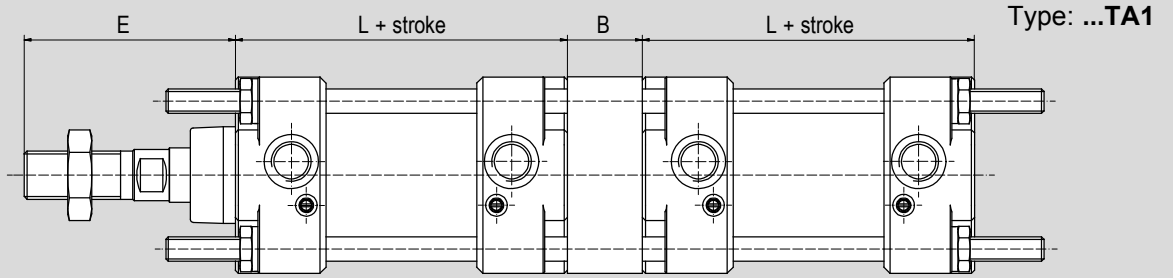

Ø mm	E	L	B	C	D
25	45	80	30	5	36
32	45	80	30	5	38
40	70	110	30	8	40
50	70	110	30	8	47
63	85	125	40	10	59
80	85	125	40	10	62
100	110	145	40	15	55
125	110	145	40	15	80
160	135	180	50	20	102
200	135	180	50	20	87

Female clevis with clip FF..CN

	For cylinder Ø mm	Code	Item	Compliance
	25-32	041081	FF10CN	-
	40-50	041082	FF16CN	
	63-80	041084	FF20CN	
	100-125	041086	FF27CN	
	160-200	-	-	

Female clevis with pin and seeger FFP..CN

	For cylinder Ø mm	Code	Item	Compliance
	25-32	041106	FFP10CN	-
	40-50	041105	FFP16CN	
	63-80	041097	FFP20CN	
	100-125	041087	FFP27CN	
	160-200	041088	FFP36CN	



On request available the clevis FFN..CN (body only) in Ø 25 ÷ 200

Male clevis with pin and seeger FM..CN



	For cylinder Ø mm	Code	Item	Compliance
	25-32	041041	FM10CN	-
	40-50	041042	FM16CN	
	63-80	041044	FM16CN	
	100-125	041046	FM27CN	
	160-200	041048	FM36CN	

On request available the clevis FMN..CN (body only) in Ø 25 ÷ 200

Rod nut D..

	For cylinder Ø mm	Code	Item	Compliance
	25-32	041453	D10x1,5	
	40-50	041455	D16x1,5	
	63-80	041456	D20x1,5	
	100-125	041458	D27x2	
	160-200	041459	D36x2	

Bearing heads (DIN 648K) with female thread RF..SE

	For cylinder Ø mm	Code	Item	Compliance
	25-32	041565	RF10x1,5SE	
	40-50	041557	RF16SE	
	63-80	041559	RF20SE	
	100-125	041562	RF30SE	
	160-200	041563	RF35SE	

Self-aligning articulated coupling GB..

	For cylinder Ø mm	Code	Item	Compliance
	25-32	041705	GB050	-
	40-50	041708	GB100	
	63-80	041709	GB120	
	100-125	041711	GB130	
	160-200	041712	GB160-200	

Axial articulated coupling RBL..

	For cylinder Ø mm	Code	Item	Compliance
	25-32	041611	RBI10x1,5	-
	50-63	041607	RBI16	
	80-100	041609	RBI20	



Angular articulated coupling RBL..

	For cylinder Ø mm	Code	Item	Compliance
	40-50	041657	RBL16	-
	63-80	041659	RBL20	

Self-aligning coupling GC..

	For cylinder Ø mm	Code	Item	Compliance
	40-50	041724	GCM16x1,5	-
	63-80	041725	GCM20x1,5	
	100-125	041726	GCM27x2	
	160-200	041727	GCM36x2	

Rear standard hinge in aluminium AN..ALCN

	For cylinder Ø mm	Code	Item	Compliance
	32	040281	AN032ALCN	
	40-50	040282	AN040/050ALCN	
	63-80	040284	AN063/080ALCN	
	100-125	040286	AN100/125ALCN	
	160-200	040288	AN160/200ALCN	

Nuts and growers to be ordered separately, see from page 1.101.20

Rear clevis* in aluminium CF..ALCN

	For cylinder Ø mm	Code	Item	Compliance
	32	040401	CF032ALCN	CNOMO
	40	040402	CF040ALCN	
	50	040403	CF050ALCN	
	63	040404	CF063ALCN	
	80	040405	CF080ALCN	
	100	040406	CF100ALCN	
	125	040407	CF125ALCN	
	160	040408	CF160ALCN	
200	040409	CF200ALCN		

*Pin SEC..AQCN to be ordered separately, see page 1.14.110
Nuts and growers to be ordered separately, see from page 1.101.20

High foot* in aluminium P..ALCN

	For cylinder Ø mm	Code	Item	Compliance
	32	040101	P032ALCN	CNOMO
	40	040102	P040ALCN	
	50	040103	P050ALCN	
	63	040104	P063ALCN	
	80	040105	P080ALCN	
	100	040106	P100ALCN	
	125	040107	P125ALCN	
	160	040108	P160ALCN	
200	040109	P200ALCN		

*Supplied individually
Nuts and growers to be ordered separately, see from page 1.101.20

Rear 90° hinge in aluminium AS..ALCN

	For cylinder Ø mm	Code	Item	Compliance
	32	040321	AS032ALCN	CNOMO
	40-50	040322	AS040/050ALCN	
	63-80	040324	AS063/080ALCN	
	100-125	040326	AS100/125ALCN	
160-200	040328	AS160/200ALCN		

Low foot* in steel PB..AQCNC

	For cylinder Ø mm	Code	Item	Compliance
	32	040161	PB032AQCNC	CNOMO
	40	040162	PB040AQCNC	
	50	040163	PB050AQCNC	
	63	040164	PB063AQCNC	
	80	040165	PB080AQCNC	
	100	040166	PB100AQCNC	
	125	040167	PB125AQCNC	
	160	040168	PB160AQCNC	
200	040169	PB200AQCNC		

*Supplied individually; Nuts and growers to be ordered separately, see from page 1.101.20

Counterbored flange in steel FL..AQCNC

	For cylinder Ø mm	Code	Item	Compliance
	32	040621	FL032AQCNC	CNOMO
	40	040622	FL040AQCNC	
	50	040623	FL050AQCNC	
	63	040624	FL063AQCNC	
	80	040625	FL080AQCNC	
	100	040626	FL100AQCNC	
	125	040627	FL125AQCNC	
	160	040628	FL160AQCNC	
200	040629	FL200AQCNC		

Nuts and growers to be ordered separately, see from page 1.101.20

Threaded flange* in steel FLF..AQCNC

	For cylinder Ø mm	Code	Item	Compliance
	32	040948	FLF032AQCNC	CNOMO
	40	040949	FLF040AQCNC	
	50	040950	FLF050AQCNC	
	63	040951	FLF063AQCNC	
	80	040952	FLF080AQCNC	
	100	040953	FLF100AQCNC	
	125	040954	FLF125AQCNC	
	160	040955	FLF160AQCNC	
200	040956	FLF200AQCNC		

*To be ordered together with the cylinder. For tie-rods dimensions, please see page 1.14.21 and 1.14.41; Nuts and growers to be ordered separately, see page 1.101.20

Bracket AS.. for magnetic reed switches T groove

	For cylinder Ø mm	Code	Item	Cylinder matching
	25 ÷ 40	072912	AS105	CM
	50 ÷ 100	072913	AS106	
	125	072909	AS102	
160 - 200	072910	AS103		

Bracket AS.. for high-temperatures magnetic reed switches

	For cylinder Ø mm	Code	Item	Cylinder matching
	25 ÷ 40	074041	AS117	CM
	50 - 63	074043	AS118	
	80 - 100	074087	AS119	
	125	074155	AS120	
160 - 200	074169	AS121		

Adjustable center trunnion* in steel with grains CT..AQC

	For cylinder Ø mm	Code	Item	Compliance
	32	040559	CT032AQC	CNOMO
	40	040558	CT040AQC	
	50	040538	CT050AQC	
	63	040540	CT063AQC	
	80	040545R	CT080AQC	
	100	040546R	CT100AQC	
	125	040580	CT125AQC	
	160	040630	CT160AQC	
200	040597	CT200AQC		

Support ST..AQIS to be ordered separately, see below.

*When mounting this accessory, the cylinder tie-rod T dimension (see page 1.14.21 or 1.14.41) is 0 for every bore. For the trunnion mounted on the cylinder, please order together with the cylinder.

Non adjustable center trunnion* in steel CTN..AQC

	For cylinder Ø mm	Code	Item	Compliance
	32	040541	CTN032AQC	CNOMO
	40	040542	CTN040AQC	
	50	040543	CTN050AQC	
	63	040544	CTN063AQC	
	80	040545	CTN080AQC	
	100	040546	CTN100AQC	
	125	040547	CTN125AQC	
	160	040548	CTN160AQC	
200	040549	CTN200AQC		

Support ST..AQIS to be ordered separately, see below.

*When mounting this accessory, the cylinder tie-rod T dimension (see page 1.14.21 or 1.14.41) is 0 for every bore. For the trunnion mounted on the cylinder, please order together with the cylinder, indicating the XV dimension (cannot be modified), see page 1.99.52

Support for center trunnion in steel ST..AQIS

	For cylinder Ø mm	Code	Item	Compliance
	32	040681	ST032AQIS	ISO AT4
	40-50	040682	ST040/050AQIS	
	63-80	040684	ST063/080AQIS	
	100-125	040686	ST100/125AQIS	
160-200	040688	ST160/200AQIS		

*Supplied individually

Pin for rear clevis in steel with seeger* SEC..AQC

	For cylinder Ø mm	Code	Item	Compliance
	32	040221	SEC032AQC	CNOMO
	40	040222	SEC040AQC	
	50	040223	SEC050AQC	
	63	040224	SEC063AQC	
	80	040225	SEC080AQC	
	100	040226	SEC100AQC	
	125	040227	SEC125AQC	
	160	040228	SEC160AQC	
	200	040229	SEC200AQC	

*Supplied with 2 seeger

Magnetic reed switch T groove ASV..

	For cylinder Ø mm	Code	Item	Cylinder matching
	25 ÷ 200	070946	ASV1C525	CM*
		071863	ASV1C550	
		071864	ASV1C51K	
		071189	ASV1C5M8	
		073639	ASV4D225	
		070246	ASV4D2M8	
		074900	ASV7N225	
		070247	ASV7N2M8	
		070372	ASV7M2M8	
072918		ASV1H525		

*With bracket AS.. for magnetic reed switches T groove, see page 1.14.91

ATEX magnetic reed switch T groove MK..

	For cylinder Ø mm	Code	Item	Compliance	Cylinder matching
	25 ÷ 200	071120	MK500A	Ex 3D	CM*
	071108	MK502A	Ex II1G		

*With bracket AS.. for magnetic reed switches T groove, see page 1.14.91

High-temperatures magnetic reed switches ASH..

	For cylinder Ø mm	Code	Item	Cylinder matching
25 ÷ 200	074047	ASH6C550	CM*	

*With bracket AS.. for high-temperatures magnetic reed switches, see page 1.14.91

COMPACT

Cylinders ISO 21287



Find out our
key products



Solution for most applications



Easy and intuitive choice



Excellent value for money



Wide availability



Fast delivery



Features and certifications

Series of compact cylinders conforming to ISO 21287 standards. The barrel with grooves allows the mounting of magnetic reed switches directly in the tube without brackets. Available in bores from Ø 16 to 125, single acting or double acting, magnetic, with elastic dampers on the piston. These cylinders are compatible with ISO 15552 mounting accessories. Supplied as standard in compliance with Reach and RoHS directives, and SIL certificated. On request, they can be also supplied according to the 2014/34/EU ATEX Directive.



Type CIS Ø 16 ÷ 100

from page 1.16.20



Compact cylinders conforming to ISO 21287, available in bores from Ø 16 to 100, single acting, magnetic, with elastic dampers on piston. Barrel with grooves allows mounting of magnetic reed switches directly, not protruding beyond the profile of the cylinder.

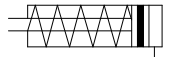

Type CI Ø 16 ÷ 125

from page 1.16.20



Compact cylinders conforming to ISO 21287, available in bores from Ø 16 to 125, double acting, magnetic, with elastic dampers on piston. Barrel with grooves allows mounting of magnetic reed switches directly, not protruding beyond the profile of the cylinder.

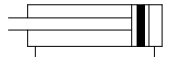

Options		
Description	Symbol	Suffix
Anti-rotating plate (available only for CI type, up to Ø 100)		N
Rear spring (available only for CIS type)		T
Male threaded rod		M
Through rod		P
FKM seals	-20°C ÷ +150°C	V
FKM rod seal	-20°C ÷ +80°C	V1
Low temperature seals	-40°C ÷ +80°C	BT
Tandem forward movement piston rods coupled together (available from Ø 20 up to Ø 100)		TA1
Tandem forward movement piston rods independent (available from Ø 20 up to Ø 100)		TA2
Tandem back to back (available from Ø 20 up to Ø 100)		TA3
Tandem front to front (available from Ø 20 up to Ø 100)		TA4
Extended rod (indicate the requested WH dimension in mm, E.g.: WH=100; for further information please contact the sales department)		WH=..
Special thread (indicate the requested thread. E.g.: R-M 10x1,5; if combined with option M, the AM dimension of the special thread will be the same as the standard; the cylinder will be supplied without rod nut; for further information please contact the sales department).		R-M..
ATEX versions on request		/ATEX
Special versions on request		/S

The options, when this is possible, can be combined with each other. For options matching see from page 1.16.4; For code key see from page 1.16.6

Options matching

Series	Bore	Model	Standard options matching				
			N (Ø16÷100)	T	M	P	V
CIS	Ø 16 ÷ 100	Standard	-	●	●	-	●
		Rear spring (T)	-		●	-	●
		Male threaded rod (M)	-	●		-	●
CI	Ø 16 ÷ 125	Standard	●	-	●	●	●
	Ø 16 ÷ 100	Anti-rotating plate (N)		-	● ⁽³⁾	●	●
	Ø 16 ÷ 125	Male threaded rod (M)	● ⁽³⁾	-		● ⁽³⁾	●
		Through rod (P)	●	-	● ⁽³⁾		●

Key
 ● allowed matching; - not allowed matching

Options matching - notes

- (1) Option **WH=.** require to indicate the desired dimension (in mm). For further information please contact the sales department.
- (2) Option **R-M.** require to indicate the desired thread. For further information please contact the sales department. if combined with male threaded rod (option **M**) the cylinder will be supplied without rod nut.
- (3) The male threaded rod (option **M**) in combination with through rod (option **P**) is applied on both sides of rod, except when combined with the anti-rotation plate (option **N**), in which case the male rod will only be applied on the side opposite the plate.

Standard options matching

V1	BT	TA1 (Ø20+100)	TA2 (Ø20+100)	TA3 (Ø20+100)	TA4 (Ø20+100)	WH=.. ⁽¹⁾	R-M.. ⁽²⁾	/ATEX
•	•	-	-	-	-	•	•	•
•	•	-	-	-	-	•	•	•
•	•	-	-	-	-	•	•	•
•	•	•	•	•	•	•	•	•
•	•	•	•	•	-	•	•	•
•	•	•	•	•	-	•	•	•
•	•	-	-	-	-	•	•	•

Code key

Bore	/	Stroke	Type	Options		
40	/	80	CI			M
Ø 16, 20, 25, 32, 40, 50, 63, 80, 100, 125		See table on page 1.16.20	CIS Single acting Magnetic CI Double acting Magnetic	N	T	M

Standard materials

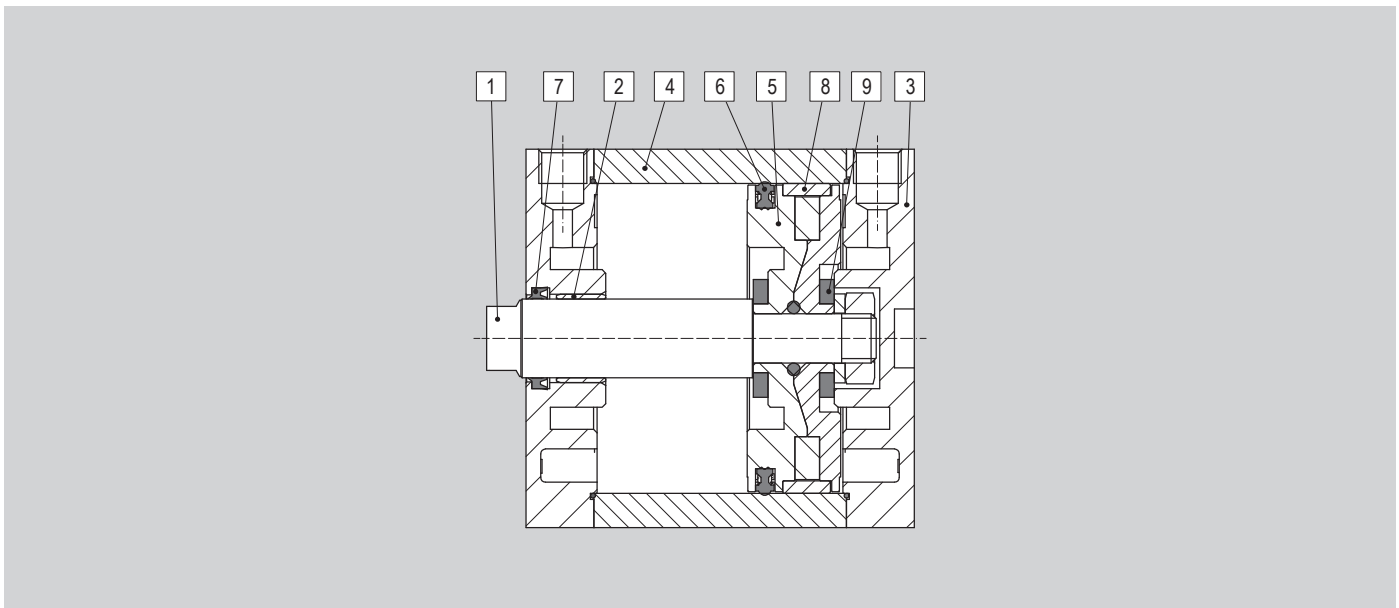

Position	Description	Materials			
		Ø 16	Ø 20 ÷ 25	Ø 32 ÷ 100	Ø 125
1	Rod	Stainless Steel AISI 304			
2	Bushing	Stainless Steel	Sintered bronze	PTFE	
3	Heads	Die-cast painted aluminium			Anodised aluminium
4	Tube	Anodised aluminium			
5	Piston	Polyurethane (PU)	POM-C / Aluminium	Aluminium	
6	Piston seal	NBR			
7	Rod seal	Polyurethane (PU)			
8	Guide ring	Steel / PTFE			
9	Elastic dampers	NBR			
-	Other seals	NBR / Polyurethane (PU)			

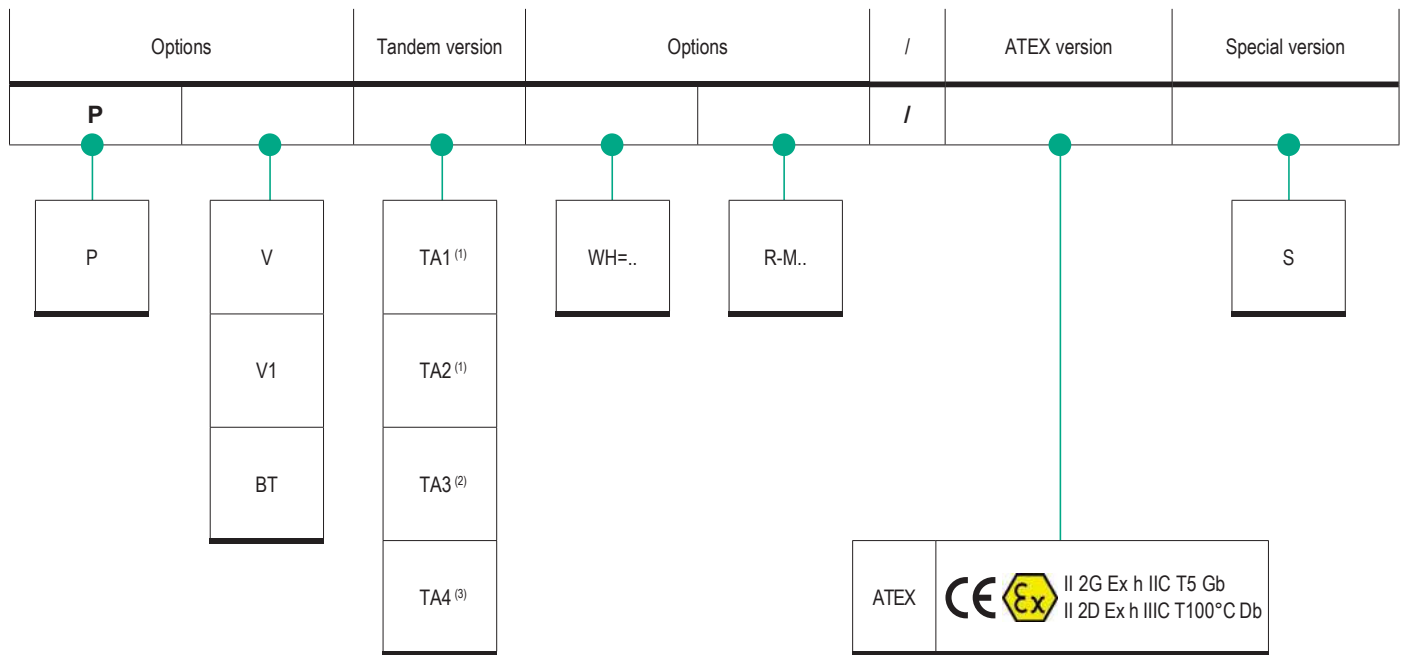

How to order

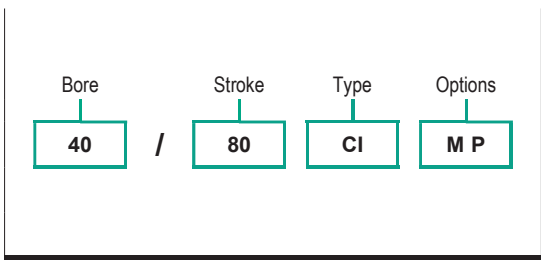

Notes

Options in the same grid are alternative to each others.
 For further information on options and their matching, see page 1.16.3 and page 1.16.4
 For further information on the ATEX 2014/34/EU Directive, on classifications and protections, see from page III.1
 (1) Available only for Ø 20, Ø 40 and Ø 63
 (2) Available from Ø 20
 (3) Available from Ø 20 to Ø 100

Standard* seal kit

Number of components	Description
n. 1	Rod seal
n. 2	Tube-head o-ring
n. 1	Piston seal
n. 2	Elastic dampers

*For cylinders with option P the kit include further components.

Standard seal kit code key

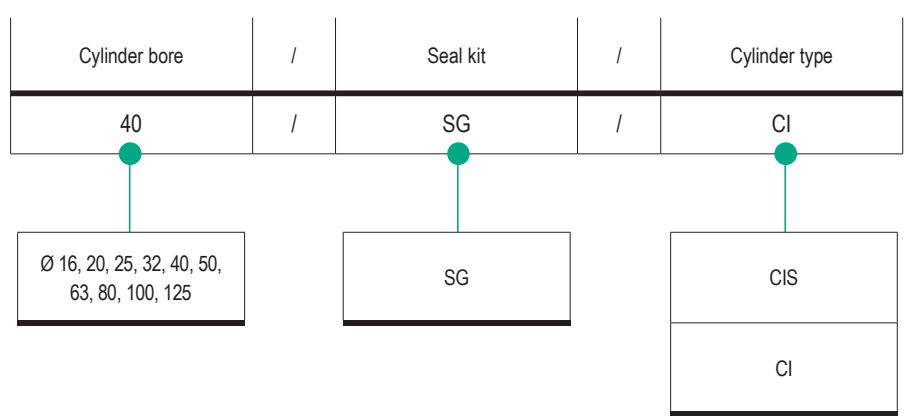

Accessories

1 - CYLINDERS

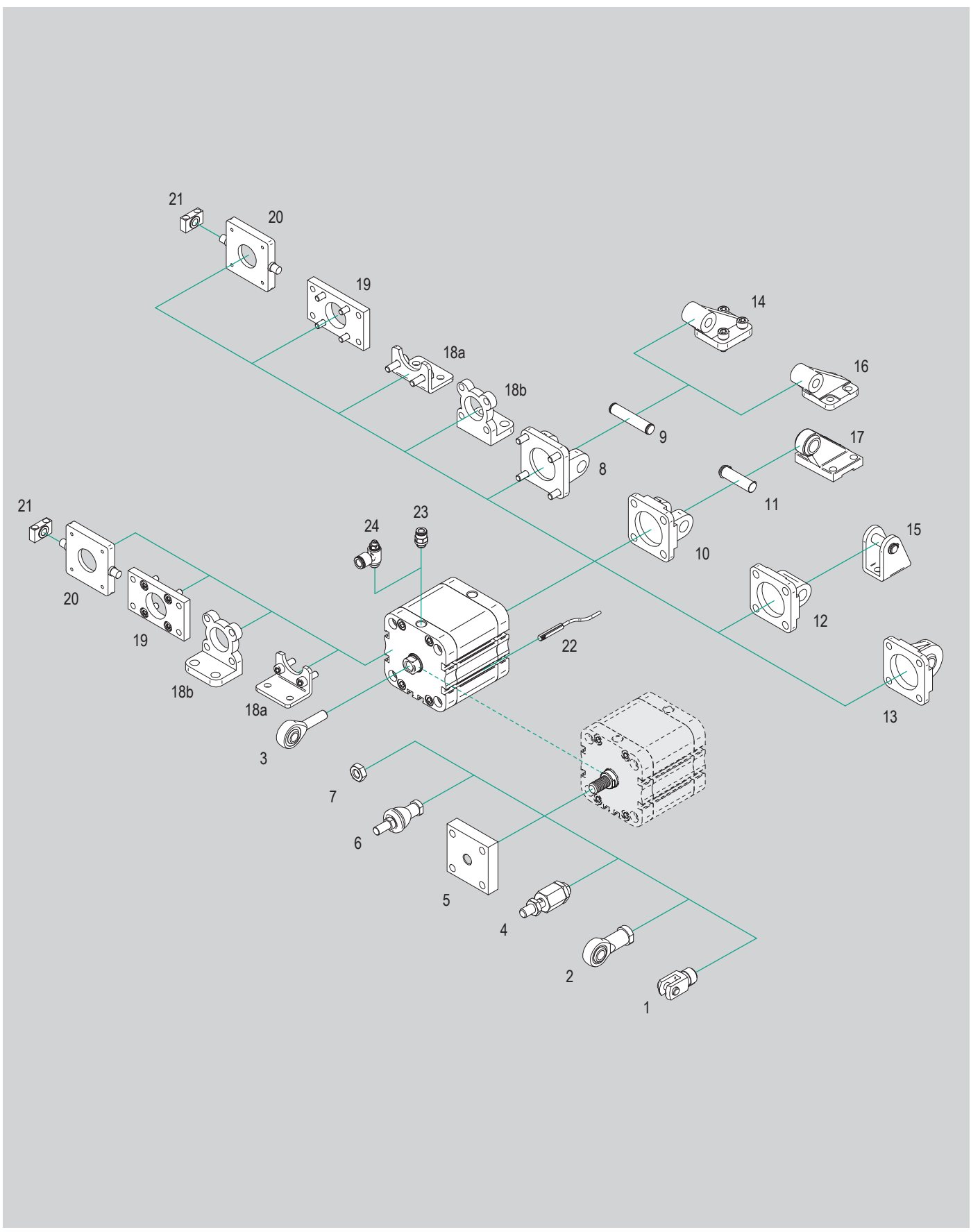

N.	Cylinder bore	Item	Description	Compliance	Matching		Code page	Data sheet page
					CIS	CI		
1	∅ 16 ÷ 125	FF..ISO	ISO female clevis with clip	ISO 8140	● ⁽¹⁾	● ⁽¹⁾	1.16.90	1.85.10
	∅ 20 ÷ 125	FFP..ISO	ISO female clevis with pin and seeger		● ⁽¹⁾	● ⁽¹⁾		1.85.11
		FFN..ISO	ISO female clevis (body only)		● ⁽¹⁾	● ⁽¹⁾		
2	∅ 16 ÷ 125	RF..SE	Bearing head (DIN 648K) with female thread	ISO 8139	● ⁽¹⁾	● ⁽¹⁾	1.90.1	
3	∅ 16 ÷ 40	RM..SE	Bearing head (DIN 648K) with male thread	DIN	●	●	1.16.90	1.90.2
	∅ 50 ÷ 125							
4	∅ 16 ÷ 125	GB..	Bearing - Self-aligning articulated coupling	-	● ⁽¹⁾	● ⁽¹⁾	1.90.10	
5	∅ 16 ÷ 125	GC..	Self-aligning coupling		● ⁽¹⁾	● ⁽¹⁾	1.90.40	
6	∅ 16 ÷ 125	RBI..	Bearing - Axial articulated coupling		● ⁽¹⁾	● ⁽¹⁾	1.90.20	
		RBL..	Bearing - Angular articulated coupling		● ⁽¹⁾	● ⁽¹⁾	1.90.30	
7	∅ 16 ÷ 125	D..	Rod nut		UNI 5589	● ⁽¹⁾	● ⁽¹⁾	1.90.70
8	∅ 32 ÷ 125	CF..ALIS	Rear clevis		ISO MP2	●	●	1.16.91
		CF..AQIS		●		●	1.100.50	
9		SEC..AQIS	Pin for rear clevis	ISO AA4	●	●	1.16.92	1.100.56
10	∅ 32 ÷ 125	CFS..ALIS	Narrow rear clevis	ISO AB6	●	●	1.16.91	1.100.2
		CFS..AQIS			●	●		1.100.50
11		SEC..ARAQIS	Anti-rotating pin for narrow rear clevis	ISO AA6	●	●	1.16.92	1.100.56
12	∅ 16 ÷ 25	CM..ALUN	Rear eye	UNITOP	●	●	1.16.91	1.100.3
	∅ 32 ÷ 125	CM..ALIS		ISO MP4	●	●		
	∅ 20 ÷ 25	CM..AQUN		UNITOP	●	●		1.100.51
	∅ 32 ÷ 125	CM..AQIS		ISO MP4	●	●		
13	∅ 32 ÷ 125	CMS..ALIS	Narrow rear eye with bearing (DIN 648K)	ISO MP6	●	●	1.100.4	
		CMS..AQIS			●	●	1.100.52	
14	∅ 32 ÷ 125	ASV..ALIS	Rear 90° hinge	ISO AB7 CETOP RP 107P	●	●	1.16.93	1.100.4
		ASV..AQIS			●	●		1.100.53
15	∅ 16 ÷ 25	CF..+P		ISO MP3	●	●	1.100.6	
16	∅ 32 ÷ 125	AS..ALIS		ISO 6431	●	●	1.100.52	
17	∅ 32 ÷ 125	ASS..AQIS	Rear 90° hinge with bearing (DIN 648K)	ISO CS7	●	●	1.100.52	
18a	∅ 16 ÷ 25	PB..AQUN	Low foot	UNITOP	●	●	1.16.92	1.100.55
	∅ 32 ÷ 125	PB..AQIS		ISO MS1	●	●		
18b	∅ 32 ÷ 125	P..ALIS	Foot	ISO MS3	●	●	1.100.6	
19	∅ 16 ÷ 25	FL..ALUN	Flange	UNITOP	●	●	1.16.92	1.100.5
		FL..AQUN			●	●		1.100.54
	∅ 32 ÷ 125	FLV..ALIS		ISO VDMA MP1/MP2	●	●		1.100.5
		FLV..AQIS		●	●	1.100.54		
20	∅ 32 ÷ 125	CTA..AQIS	Center trunnion for heads	ISO MT5/MT6	●	●	1.16.93	1.100.57
21	∅ 32 ÷ 125	ST..AQIS	Support for center trunnion	ISO AT4	●	●		
22	∅ 16 ÷ 125	ASV..	Magnetic reed switch T groove	-	●	●	1.110.10	
		MK..	ATEX magnetic reed switch T groove	2014/34/EU	●	●	1.113.1	
23	∅ 16 ÷ 125	R..	Push-in fittings	-	●	●	4.2.1	
24	∅ 16 ÷ 125	V..C	Flow controls, for cylinders	-	●	●	4.94.1	

Key
● matching accessory; - not matching accessory

(1) Matching only with option M

Main features

16 ÷ 100

Bores Ø

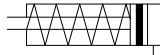

Single acting
Magnetic
With female thread

CIS

Type



16 ÷ 125

Bores Ø

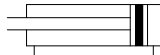

Double acting
Magnetic
With female thread

CI

Type



Technical data

Bore Ø mm	16	20	25	32	40	50	63	80	100	125	
Fluid	Filtered compressed air with or without lubrication. Lubrication, if started, must be continued.										
Pressure range	2 ÷ 10 bar										
Temperature range	-20°C ÷ +80°C (standard / V1)			-20°C ÷ +150°C (V)				-40°C ÷ +80°C (BT)			
Port	M5			1/8"				1/4"			
Grooves for reed switches	3			5				6		4	
Strokes	CIS	5 ÷ 50 mm								-	
	CI*	5 ÷ 250 mm			5 ÷ 400 mm						
Rod thread	CI-CIS	M4	M6	M8		M10		M12		M16	
	CIM-CISM	M6	M8x1,25	M10x1,25		M12x1,25		M16x1,5		M20x1,5	

* With option N the maximum stroke is 200 mm

Standard strokes

Stroke mm	CIS Bore Ø mm								
	16	20	25	32	40	50	63	80	100
5									
10									
15									
20									
25									
30									
40									
50									

Stroke mm	CI Bore Ø mm										
	16	20	25	32	40	50	63	80	100	125	
5	✓	✓	✓	✓	✓	✓	✓	✓			
10	✓	✓	✓	✓	✓	✓	✓	✓			
15	✓	✓	✓	✓	✓	✓	✓	✓			
20	✓	✓	✓	✓	✓	✓	✓	✓			
25	✓	✓	✓	✓	✓	✓	✓	✓			
30	✓	✓	✓	✓	✓	✓	✓	✓			
40	✓	✓	✓	✓	✓	✓	✓	✓			
50	✓	✓	✓	✓	✓	✓	✓	✓			
60		✓	✓	✓	✓	✓	✓	✓			
80				✓	✓	✓	✓	✓			
100											
160											
200											
250											
300											
350											
400											

Key
 Standard stroke

Theoretical thrust force Unit: N

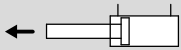

Ø Cylinder (mm)	Pressure (bar)
	6
16	-
20	188
25	294
32	482
40	754
50	1178
63	1869
80	3014
100	4710
125	-

Theoretical traction force Unit: N

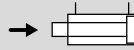

Ø Cylinder (mm)	Pressure (bar)
	6
16	-
20	141
25	247
32	414
40	633
50	989
63	1681
80	2720
100	4416
125	-

Theoretical spring force (for CIS type only) Unit: N

Ø Cylinder (mm)	Strokes (mm)															
	5		10		15		20		25		30		40		50	
	F1	F2	F1	F2	F1	F2	F1	F2	F1	F2	F1	F2	F1	F2	F1	F2
16	-	-	-	-	-	-	-	-	-	-	-	-	-	-	-	-
20	22	25	20	25	17	25	14	25	11	25	-	-	-	-	-	-
25	30	33	26	33	23	33	20	33	16	33	-	-	-	-	-	-
32	50	54	46	54	42	54	38	54	34	54	-	-	-	-	-	-
40	52	55	50	55	46	55	43	55	40	55	-	-	-	-	-	-
50	59	63	54	63	49	63	44	63	39	63	-	-	-	-	-	-
63	72	78	67	78	62	78	56	78	51	78	-	-	-	-	-	-
80	110	116	105	116	100	116	95	116	89	116	-	-	-	-	-	-
100	152	159	144	159	136	159	129	159	121	159	-	-	-	-	-	-

Standard dimensions

Type: **CIS-CI**
Ø 16 ÷ 25

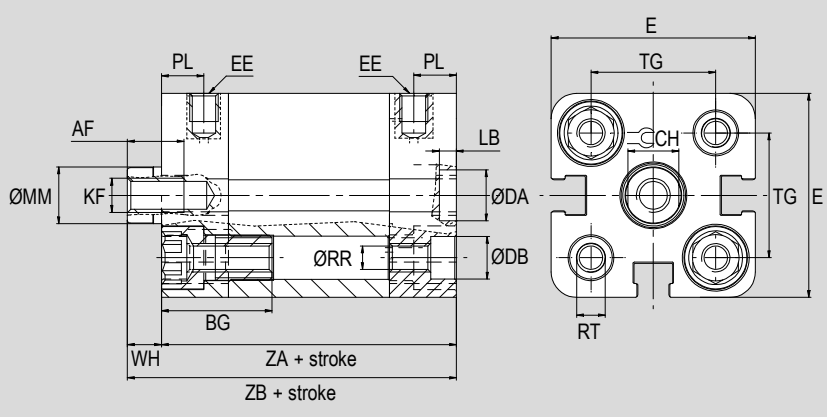

Type: **CIS-CI**
Ø 32 ÷ 50

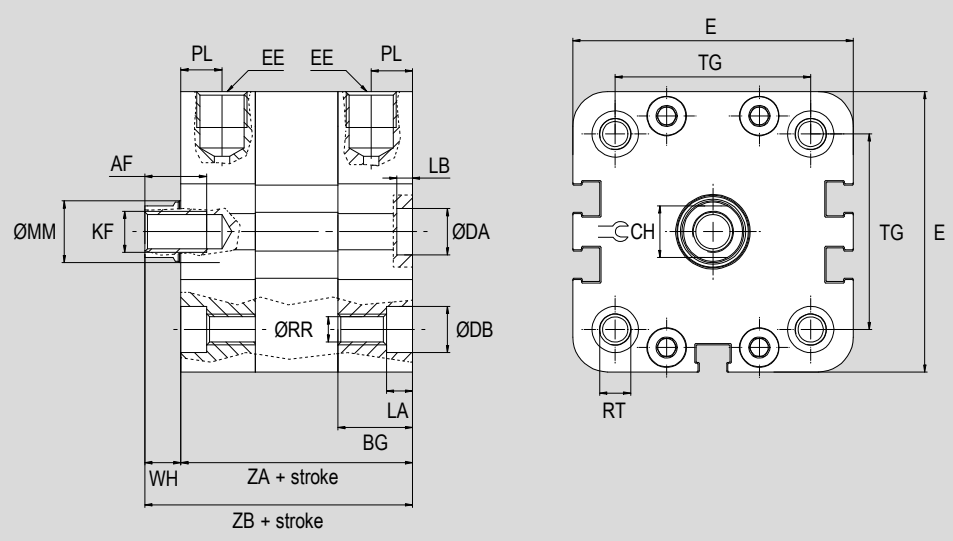

Ø (mm)	ØMM f7	AF	WH	ZA*	ZB*	KF	EE	BG	RR	TG	E	RT	LA	ØDB	PL	CH	ØDA h9	LB +0.1
16	8	10	4.5	35	39,5	M4	M5	11	3,2	18	29	M4	3,5	6	6,5	7	9	2,1
20	10	10	6	37	43	M6	M5	19,5	4,1	22	36	M5	4,5	7,5	7,5	9	9	3
25	10	10	6	39	45	M6	M5	19,5	4,1	26	40	M5	4,5	7,5	7,5	9	9	3
32	12	12	7	44	51	M8	G1/8"	14	5,1	32,5	49	M6	4,5	8	7,5	10	9	3
40	12	12	7	45	52	M8	G1/8"	14,5	5,1	38	54,5	M6	5	9	8	10	9	3
50	16	16	8	45	53	M10	G1/8"	14,5	6,6	46,5	65,5	M8	5	10,5	8	13	12	4

* CIS type Ø 20 ÷ 50, for strokes > 25 mm, add +20 mm to dimension;

Standard dimensions

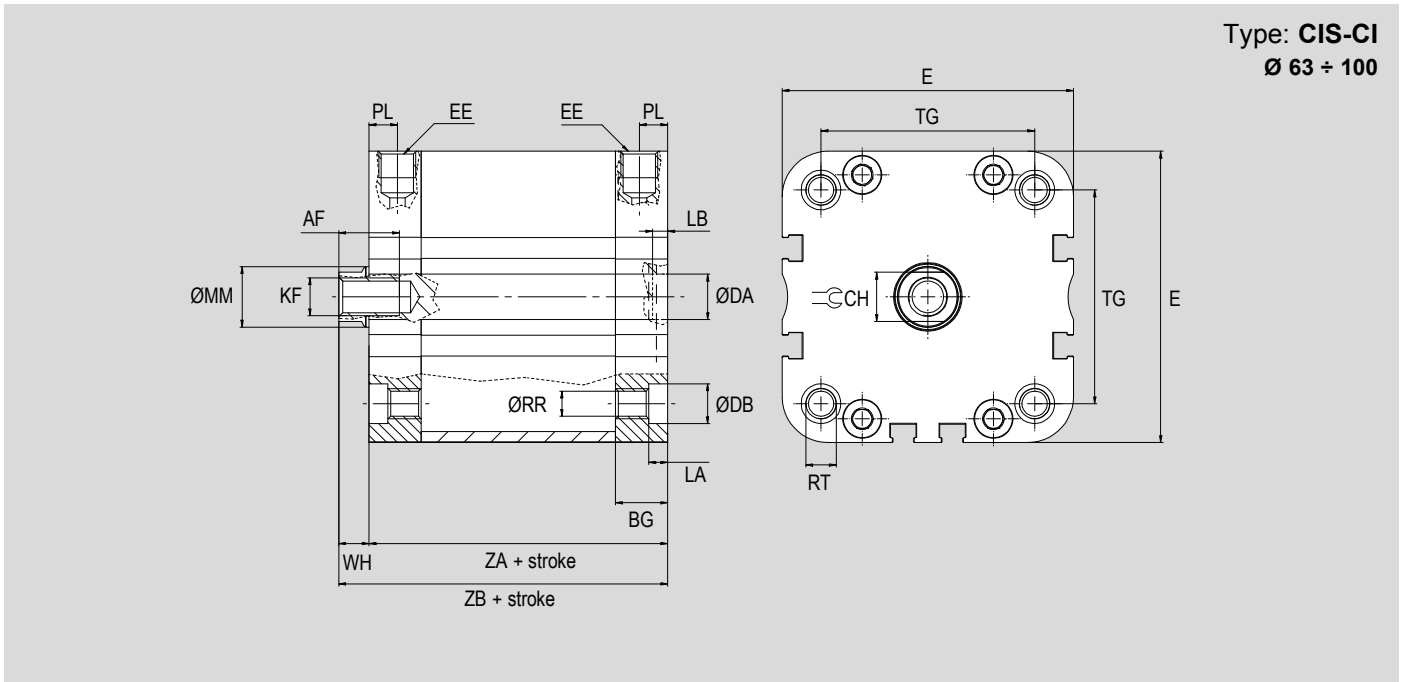

1 - CYLINDERS

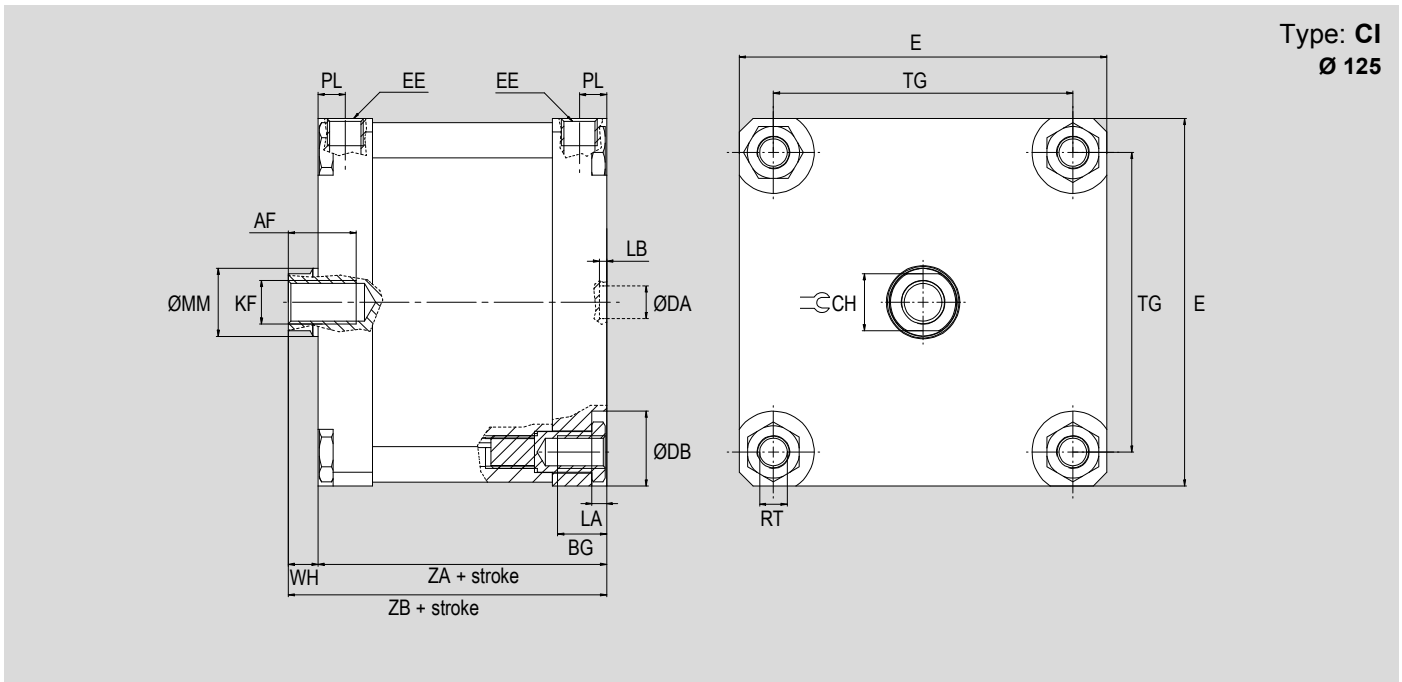

Ø (mm)	ØMM f7	AF	WH	ZA*	ZB*	KF	EE	BG	RR	TG	E	RT	LA	ØDB	PL	CH	ØDA h9	LB +0.1
63	16	16	8	49	57	M10	G1/8"	13,8	6,6	56,5	77	M8	5	10,5	7,5	13	12	4
80	20	20	10	54	64	M12	G1/8"	15	8,4	72	95,5	M10	3	13,5	8	17	12	4
100	25	20	10	67	77	M12	G1/8"	19,5	8,4	89	113,5	M10	3	14	10,5	21	12	4
125	25	25	11	81	92	M16	G1/4"	20	-	110	135	M12	-	-	10	21	12	2,6

* CIS type Ø 63 ÷ 100, for strokes > 25 mm, add +20 mm to dimension;

Dimensions with options

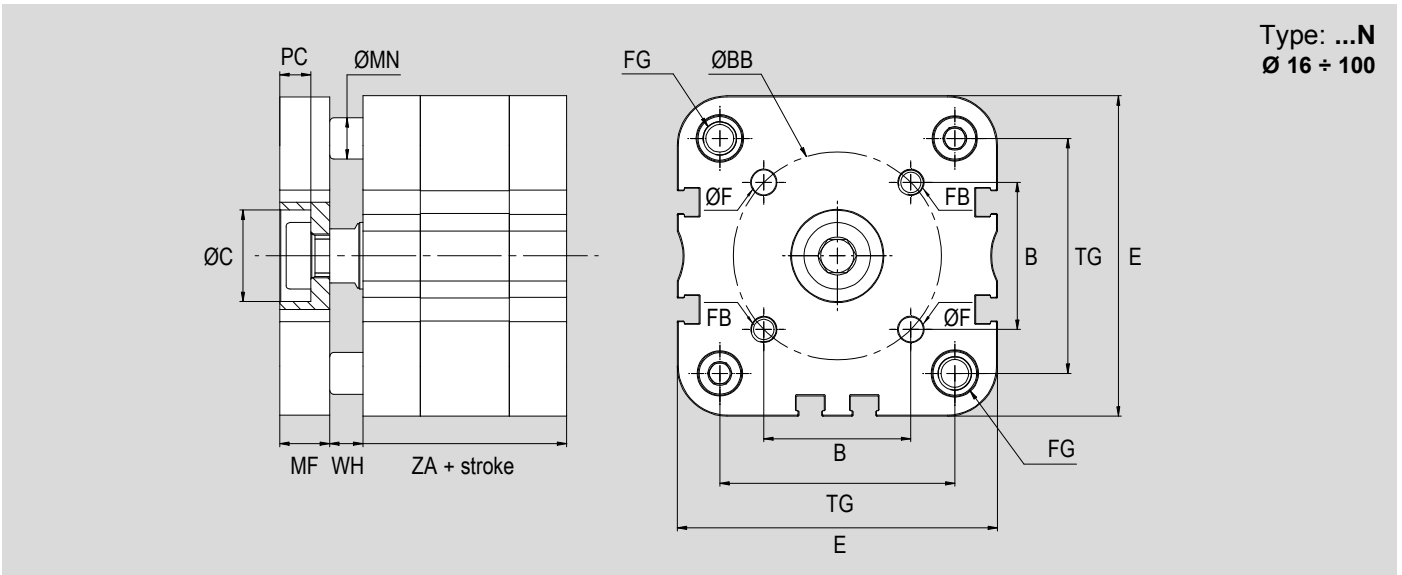
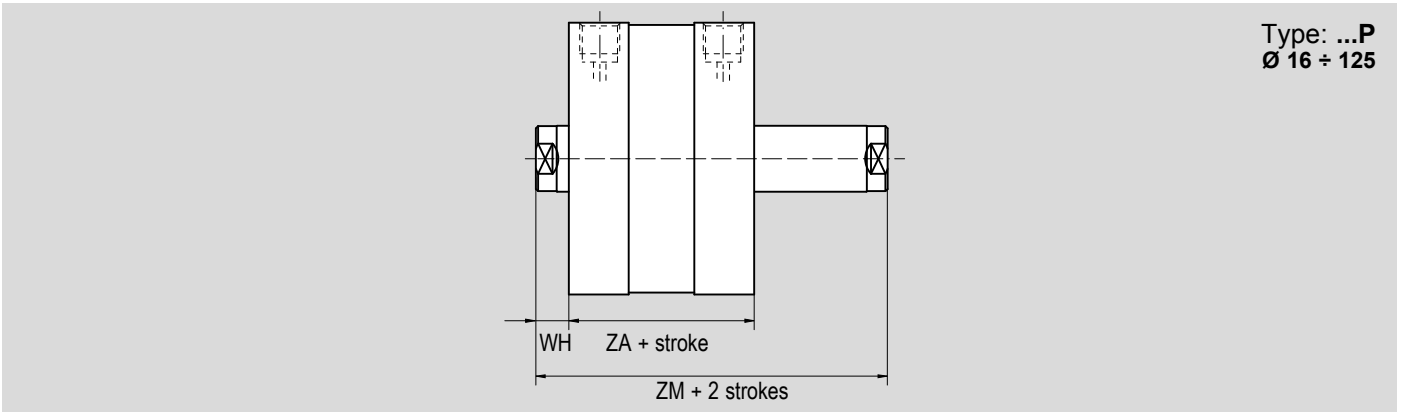
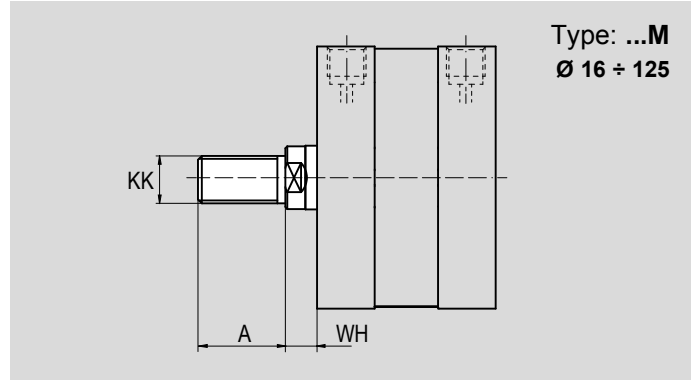
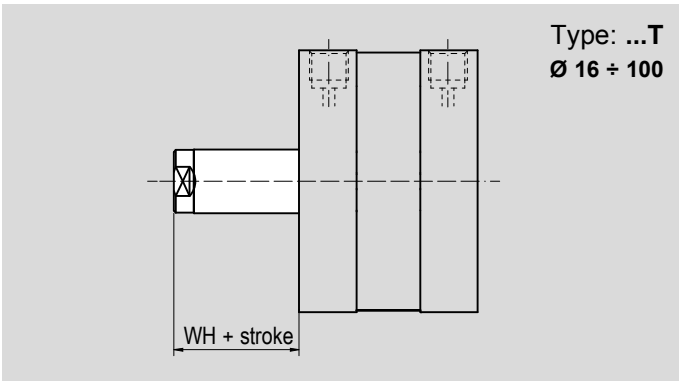

Ø (mm)	WH	MF +0.1	E	TG	B	FG	ØBB ±0.1	ØF +0.1	FB	ØC H9	PC	MN f7	ZA*	ZM*	KK	A
16	4,1	6	29	18	10	M4	14	3	M3	7,5	4,5	6	35	43,2	M6	12
20	6	8	36	22	12	M5	17	4	M4	11	5	6	37	49	M8x1,25	16
25	6	8	40	26	15,6	M5	22	5	M5	14	5	6	39	51	M8x1,25	16
32	7	10	49	32,5	19,8	M6	28	5	M5	17	6,5	6	44	58	M10x1,25	19
40	7	10	54,5	38	23,3	M6	33	5	M5	17	6,5	8	45	59	M10x1,25	19
50	8	12	65,5	46,5	29,7	M8	42	6	M6	22	7,5	10	45	61	M12x1,25	22
63	8	12	77	56,5	35,4	M8	50	6	M6	22	7,5	10	49	65	M12x1,25	22
80	10	14	95,5	72	46	M10	65	8	M8	28	9	14	54	74	M16x1,5	28
100	10	14	113,5	89	56,6	M10	80	10	M10	30	10	14	67	87	M16x1,5	28
125	11	-	-	-	-	-	-	-	-	-	-	-	81	103	M20x1,5	40

* CIS type Ø 20 ÷ 100, for strokes > 25 mm, add +20 mm to dimension;

Dimensions tandem versions

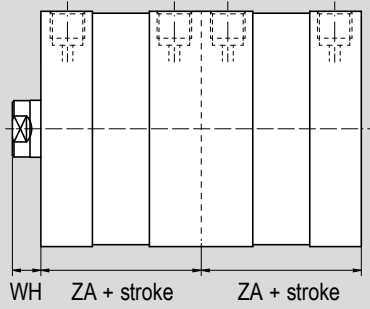

Type: ...TA1
Ø 25 - 40 - 63

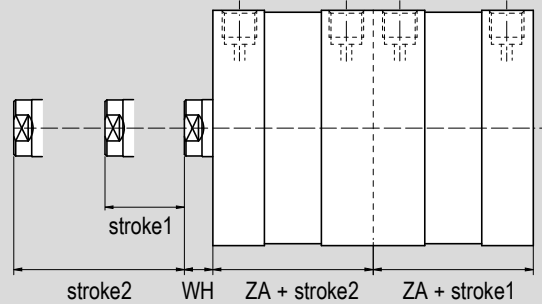

Type: ...TA2
Ø 25 - 40 - 63

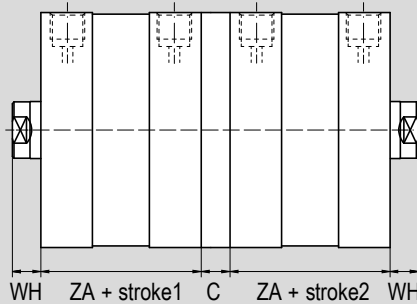

Type: ...TA3
Ø 20 ÷ 125

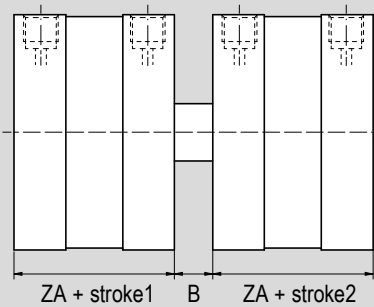

Type: ...TA4
Ø 20 ÷ 100

Ø mm	WH	ZA	B	C
20	6	37	9	13
25	6	39	11	13
32	7	44	12	15
40	7	45	13	15
50	8	45	15	15
63	8	49	15	15
80	10	54	16	17
100	10	67	20	19,5
125	11	81	-	19,5

Female clevis with clip FF..ISO

	For cylinder Ø mm	Code	Item	Compliance
	16	041002	FF06ISO/DIN	
	20-25	041003	FF08ISO/DIN	
	32-40	041004	FF10ISO	
	50-63	041005	FF12ISO	
	80-100	041006	FF16ISO	
	125	041007	FF20ISO	

Matching with option M only

Female clevis with pin and seeger FFP..ISO

	For cylinder Ø mm	Code	Item	Compliance
	16	-	FFP06ISO/DIN	
	20-25	-	FFP08ISO/DIN	
	32-40	041051	FFP10ISO	
	50-63	041040	FFP12ISO	
	80-100	041013	FFP16ISO	
	125	041017	FFP20ISO	

Matching with option M only

Female clevis (body only) FFN..ISO

	For cylinder Ø mm	Code	Item	Compliance
	16	041011	FFN06ISO/DIN	
	20-25	041018	FFN08ISO/DIN	
	32-40	041014	FFN10ISO	
	50-63	041016	FFN12ISO	
	80-100	041012	FFN16ISO	
	125	041015	FFN20ISO	

Matching with option M only

Bearing heads (DIN 648K) with female thread RF..SE

	For cylinder Ø mm	Code	Item	Compliance
	16	041552	RF6SE	
	20-25	041553	RF8SE	
	32-40	041554	RF10SE	
	50-63	041555	RF12SE	
	80-100	041557	RF16SE	
	125	041559	RF20SE	

Matching with option M only

Bearing heads (DIN 648K) with male thread RM..SE

	For cylinder Ø mm	Code	Item	Compliance
	16	041500	RM4SE	
	20-25	041502	RM6SE	
	32-40	041503	RM8SE	
	50-63	041550	RM10SE/M10x1,5	
	80-100	041514	RM12SE/M12	
	125	041517	RM16SE/M16	

Self-aligning articulated coupling GB..

	For cylinder Ø mm	Code	Item	Compliance
	16	041702	GB010	-
	20-25	041703	GB020	
	32-40	041704	GB040	
	50-63	041706	GB060	
	80-100	041708	GB100	
	125	041709	GB120	

Matching with option M only

Axial articulated coupling RBL..

	For cylinder Ø mm	Code	Item	Compliance
	32-40	041604	RBL10	-
	50-63	041605	RBL12	
	80-100	041607	RBL16	
	125	041609	RBL20	

Matching with option M only

Angular articulated coupling RBL..

	For cylinder Ø mm	Code	Item	Compliance
	32-40	041654	RBL10	-
	50-63	041655	RBL12	
	80-100	041657	RBL16	
	125	041659	RBL20	

Matching with option M only

Self-aligning coupling GC..

	For cylinder Ø mm	Code	Item	Compliance
	32-40	041722	GCM10x1,25	-
	50-63	041723	GCM12x1,25	
	80-100	041724	GCM16x1,5	
	125	041725	GCM20x1,5	

Matching with option M only

Rear clevis in aluminium with screws and pin CF..ALIS+VP

	For cylinder Ø mm	Code	Item	Compliance
	32	042050	CF032ALIS+VP	
	40	042051	CF040ALIS+VP	
	50	042052	CF050ALIS+VP	
	63	042053	CF063ALIS+VP	
	80	042054	CF080ALIS+VP	
	100	042055	CF100ALIS+VP	
	125	042056	CF125ALIS+VP	

Narrow rear clevis in aluminium with screws and pin CFS..ALIS+VP

	For cylinder Ø mm	Code	Item	Compliance
	32	042110	CFS032ALIS+VP	
	40	042111	CFS040ALIS+VP	
	50	042112	CFS050ALIS+VP	
	63	042113	CFS063ALIS+VP	
	80	042114	CFS080ALIS+VP	
	100	042115	CFS100ALIS+VP	
	125	042116	CFS125ALIS+VP	

Rear clevis in aluminium* with screws CF..ALIS+V

	For cylinder Ø mm	Code	Item	Compliance
	32	040441	CF032ALIS+V	
	40	040442	CF040ALIS+V	
	50	040443	CF050ALIS+V	
	63	040444	CF063ALIS+V	
	80	040445	CF080ALIS+V	
	100	040446	CF100ALIS+V	
	125	040447	CF125ALIS+V	

Narrow rear clevis in aluminium* with screws CFS..ALIS+V

	For cylinder Ø mm	Code	Item	Compliance
	32	040451	CFS032ALIS+V	
	40	040452	CFS040ALIS+V	
	50	040453	CFS050ALIS+V	
	63	040454	CFS063ALIS+V	
	80	040455	CFS080ALIS+V	
	100	040456	CFS100ALIS+V	
	125	040457	CFS125ALIS+V	

*Available also in steel (item CF..AQIS+V) in Ø 32 ÷ 125, see page 1.100.50

*Available also in steel (item CFS..AQIS+V) in Ø 32 ÷ 125, see page 1.100.50

Rear eye in aluminium* CM..ALUN

	For cylinder Ø mm	Code	Item	Compliance
	16	040701	CM012/016ALUN	
	20	040702	CM020ALUN	
	25	040703	CM025ALUN	

*Available also in steel (item CM..AQUN) in Ø 20 ÷ 25, see page 1.100.51
Screws to be ordered separately, see page 1.101.40

Rear eye in aluminium* with screws CM..ALIS+V

	For cylinder Ø mm	Code	Item	Compliance
	32	042061	CM032ALIS+V	
	40	042062	CM040ALIS+V	
	50	042063	CM050ALIS+V	
	63	042064	CM063ALIS+V	
	80	042065	CM080ALIS+V	
	100	042066	CM100ALIS+V	
	125	042067	CM125ALIS+V	

*Available also in steel (item CM..AQIS+V) in Ø 32 ÷ 125, see page 1.100.51

Narrow rear eye with bearing (DIN 648K) in aluminium* with screws CMS..ALIS+V

	For cylinder Ø mm	Code	Item	Compliance
	32	042101	CMS032ALIS+V	
	40	042102	CMS040ALIS+V	
	50	042103	CMS050ALIS+V	
	63	042104	CMS063ALIS+V	
	80	042105	CMS080ALIS+V	
	100	042106	CMS100ALIS+V	
	125	042107	CMS125ALIS+V	

Available also in steel (item CMS..AQIS+V) in Ø 32 ÷ 125, see page 1.100.52

Rod nut D..

	For cylinder Ø mm	Code	Item	Compliance
	16	041450	D6x1	
	20-25	041451	D8x1,25	
	32-40	041452	D10x1,25	
	50-63	041454	D12x1,25	
	80-100	041455	D16x1,5	
	25	041456	D20x1,5	

Matching with option M only

Pin with seeger* in steel SEC..AQIS

	For cylinder Ø mm	Code	Item	Compliance
	32	040261	SEC032AQIS	
	40	040262	SEC040AQIS	
	50	040263	SEC050AQIS	
	63	040264	SEC063AQIS	
	80	040265	SEC080AQIS	
	100	040266	SEC100AQIS	
	125	040267	SEC125AQIS	

*Supplied with 2 seeger

Anti-rotating pin with seeger* in steel SEC..ARAQIS

	For cylinder Ø mm	Code	Item	Compliance
	32	040571	SEC032ARAQIS	
	40	040572	SEC040ARAQIS	
	50	040573	SEC050ARAQIS	
	63	040574	SEC063ARAQIS	
	80	040575	SEC080ARAQIS	
	100	040576	SEC100ARAQIS	
	125	040577	SEC125ARAQIS	

*Supplied with 1 seeger

Flange in aluminium FL..ALUN

	For cylinder Ø mm	Code	Item	Compliance
	12-16	040721	FL012/016ALUN	
	20	040722	FL020ALUN	
	25	040723	FL025ALUN	

Screws to be ordered separately, see page 1.101.40

Flange in aluminium with screws FLV..ALIS+V

	For cylinder Ø mm	Code	Item	Compliance
	32	042150	FLV032ALIS+V	
	40	042151	FLV040ALIS+V	
	50	042152	FLV050ALIS+V	
	63	042153	FLV063ALIS+V	
	80	042154	FLV080ALIS+V	
	100	042155	FLV100ALIS+V	
	125	042156	FLV125ALIS+V	

Flange in steel FL..AQUN

	For cylinder Ø mm	Code	Item	Compliance
	12-16	040751	FL012/016AQUN	
	20	040752	FL020AQUN	
	25	040753	FL025AQUN	

Screws to be ordered separately, see page 1.101.40

Flange in steel with screws FLV..AQIS+V

	For cylinder Ø mm	Code	Item	Compliance
	32	042119	FLV032AQIS+V	
	40	042120	FLV040AQIS+V	
	50	042121	FLV050AQIS+V	
	63	042122	FLV063AQIS+V	
	80	042123	FLV080AQIS+V	
	100	042124	FLV100AQIS+V	
	125	042125	FLV125AQIS+V	

Low foot* in steel PB..AQUN

	For cylinder Ø mm	Code	Item	Compliance
	16	040761	PB012/016AQUN	
	20	040762	PB20AQUN	
	25	040763	PB25AQUN	

*Supplied individually



Screws to be ordered separately, see page 1.101.40

Low foot in steel* with screws PB..AQIS+V

	For cylinder Ø mm	Code	Item	Compliance
	32	042129	PB032AQIS+V	
	40	042130	PB040AQIS+V	
	50	042131	PB050AQIS+V	
	63	042132	PB063AQIS+V	
	80	042133	PB080AQIS+V	
	100	042134	PB100AQIS+V	
	125	042135	PB125AQIS+V	



*Supplied individually and available also in version foot, made of aluminium (item P..ALIS), for Ø 32 ÷ 125, see page 1.100.6

Center trunnion for heads in steel with screws CTA..AQIS+V

	For cylinder Ø mm	Code	Item	Compliance
	32	040591	CTA032AQIS+V	 MT5/MT6
	40	040592	CTA040AQIS+V	
	50	040593	CTA050AQIS+V	
	63	040594	CTA063AQIS+V	
	80	040595	CTA080AQIS+V	
	100	040596	CTA100AQIS+V	
125	040598	CTA125AQIS+V		



Support ST..AQIS to be ordered separately, see next

Support for center trunnion* in steel ST..AQIS

	For cylinder Ø mm	Code	Item	Compliance
	32	040681	ST032AQIS	 AT4
	40-50	040682	ST040/050AQIS	
	63-80	040684	ST063/080AQIS	
	100-125	040686	ST100/125AQIS	



*Supplied individually

Rear 90° hinge in aluminium* with screws ASV..ALIS+V



	For cylinder Ø mm	Code	Item	Compliance
	32	042081	ASV032ALIS+V	 AB7  RP 107P
	40	042082	ASV040ALIS+V	
	50	042083	ASV050ALIS+V	
	63	042084	ASV063ALIS+V	
	80	042085	ASV080ALIS+V	
	100	042086	ASV100ALIS+V	
125	042087	ASV125ALIS+V		

*Available also in steel: item CF..+P for Ø 16 ÷ 25 and item ASV..AQIS for Ø 32 ÷ 125, see page 1.100.53



Rear 90° hinge in aluminium AS..ALIS

	For cylinder Ø mm	Code	Item	Compliance
	32	040361	AS032ALIS	 6431
	40	040362	AS040ALIS	
	50	040363	AS050ALIS	
	63	040364	AS063ALIS	
	80	040365	AS080ALIS	
	100	040366	AS100ALIS	
125	040367	AS125ALIS		





Rear 90° hinge with bearing (DIN 648K) in steel ASS..AQIS

	For cylinder Ø mm	Code	Item	Compliance
	32	040551	ASS032AQIS	 CS7
	40	040552	ASS040AQIS	
	50	040553	ASS050AQIS	
	63	040554	ASS063AQIS	
	80	040555	ASS080AQIS	
	100	040556	ASS100AQIS	
125	040557	ASS125AQIS		

Magnetic reed switch T groove ASV..

	For cylinder Ø mm	Code	Item	Cylinder matching
	16 ÷ 125	070946	ASV1C525	 CIS CI
		071863	ASV1C550	
		071864	ASV1C51K	
		071189	ASV1C5M8	
		073639	ASV4D225	
		070246	ASV4D2M8	
		074900	ASV7N225	
		070247	ASV7N2M8	
		070372	ASV7M2M8	
		072918	ASV1H525	

ATEX magnetic reed switch T groove MK..

	For cylinder Ø mm	Code	Item	Compliance	Cylinder matching
	16 ÷ 125	071120	MK500A	 3D	 CIS CI
	071108	MK502A	 II1G		

Notes

COMPACT

Cylinders UNITOP



Find out our
key products



Solution for most applications



Easy and intuitive choice



Excellent value for money



Wide availability



Fast delivery



Features and certifications

Series of compact cylinders conforming to European UNITOP standards. The barrel with grooves allows the mounting of magnetic reed switches directly in the tube without brackets. Available in bores from \varnothing 12 to 100, single acting or double acting, magnetic, with elastic dampers on the piston. Supplied as standard in compliance with Reach and RoHS directives, and SIL certificated. On request, they can be also supplied according to the 2014/34/EU ATEX Directive.



Type CS \varnothing 12 ÷ 100

from page 1.17.20



Compact cylinders conforming to European UNITOP standards, available in bores from \varnothing 12 to 100, single acting, magnetic with elastic dampers on piston. Barrel with grooves allows mounting of magnetic reed switches directly, not protruding beyond the profile of the cylinder.

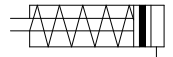

Type CD \varnothing 12 ÷ 100

from page 1.17.20



Compact cylinders conforming to European UNITOP standards, available in bores from \varnothing 12 to 100, double acting, magnetic with elastic dampers on piston. Barrel with grooves allows mounting of magnetic reed switches directly, not protruding beyond the profile of the cylinder.

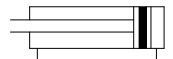

Options		
Description	Symbol	Suffix
Anti-rotating plate (available only for CD type, from Ø 16)		N
Rear spring (available only for CS type)		T
Male threaded rod		M
Through rod		P
FKM-PPDI seals	-20°C ÷ +135°C 	V
ATEX versions on request		/ATEX
Special versions on request		/S

The options, when this is possible, can be combined with each other. For options matching see from page 1.17.4; For code key see from page 1.17.5

Options matching

Series	Bore	Model	Standard options matching					
			N (Ø16÷100)	T	M	P	V	/ATEX
CS	Ø 12 ÷ 100	Standard	-	●	●	●	●	●
		Rear spring (T)	-		●	-	●	●
		Male threaded rod (M)	-	●		● ¹	●	●
		Through rod (P)	-	-	● ¹		●	●
CD	Ø 12 ÷ 100	Standard	●	-	●	●	●	●
	Ø 16 ÷ 100	Anti-rotating plate (N)		-	● ¹	●	●	●
	Ø 12 ÷ 100	Male threaded rod (M)	● ¹	-		● ¹	●	●
		Through rod (P)	●	-	● ¹		●	●

Key
 ● allowed matching; - not allowed matching

Options matching - notes

(1) The male threaded rod (option **M**) in combination with through rod (option **P**) is applied on both sides of rod, except when combined with the anti-rotation plate (option **N**), in which case the male rod will only be applied on the side opposite the plate.

Standard materials

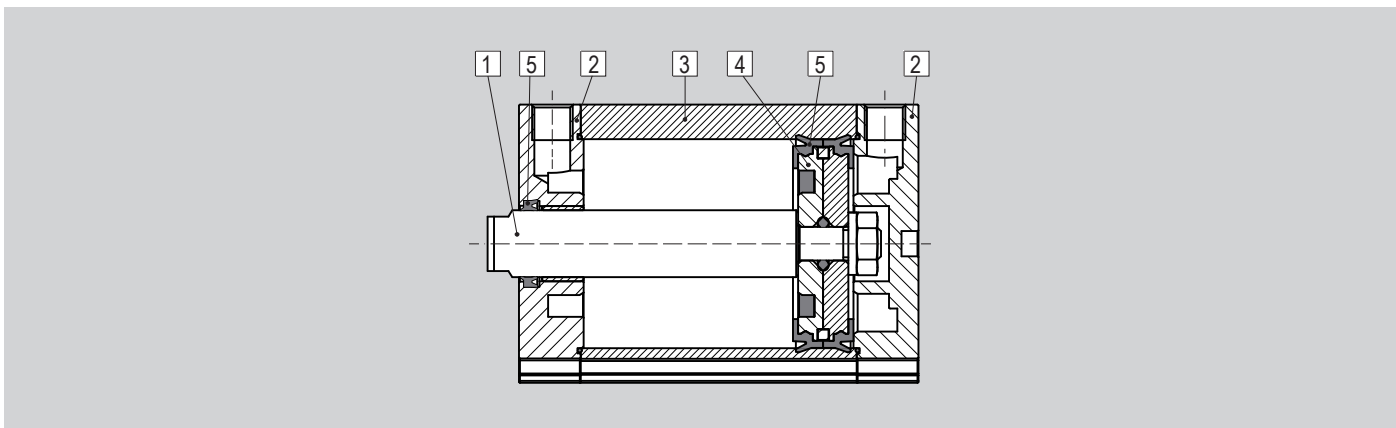

Position	Description	Materials
1	Rod	Stainless Steel AISI 304
2	Heads	Anodised aluminium
3	Tube	Anodised aluminium
4	Piston	Aluminium
5	Seals	NBR / Polyurethane (PU)
-	Anti-rotating plate (option N)	Anodised aluminium

Code key

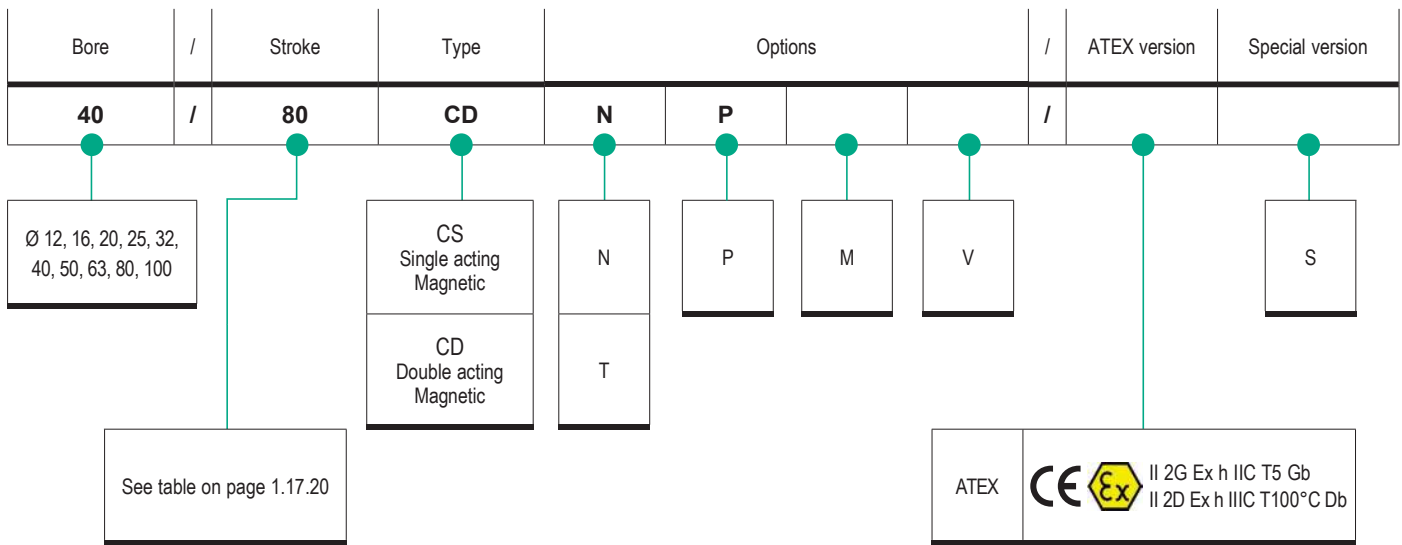

How to order

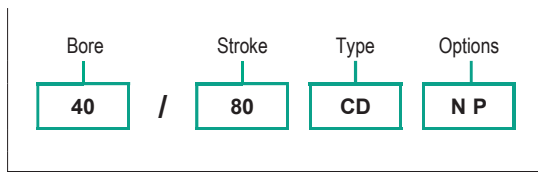

Notes

Options in the same grid are alternative to each others.
 For further information on options and their matching, see page 1.17.3 and page 1.17.4
 For further information on the ATEX 2014/34/EU Directive, on classifications and protections, see from page III.1

Standard* seal kit

Number of components	Description
n. 1	Rod seal
n. 2	Tube-head o-ring
n. 2	Piston seal

*For cylinders with option P, the kit include further components

Standard seal kit code key

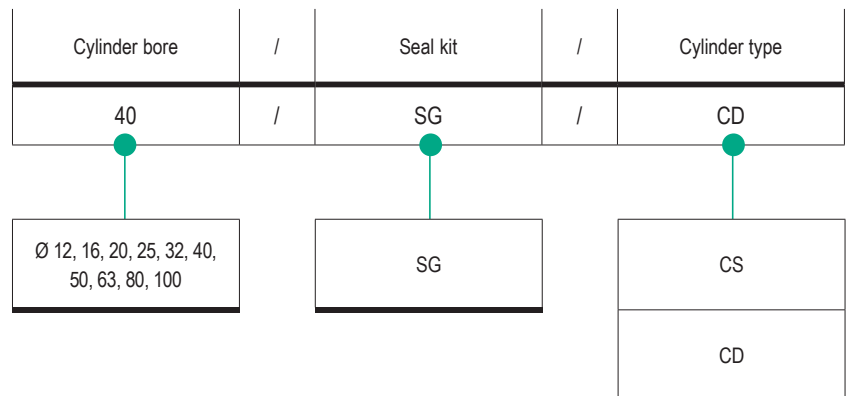

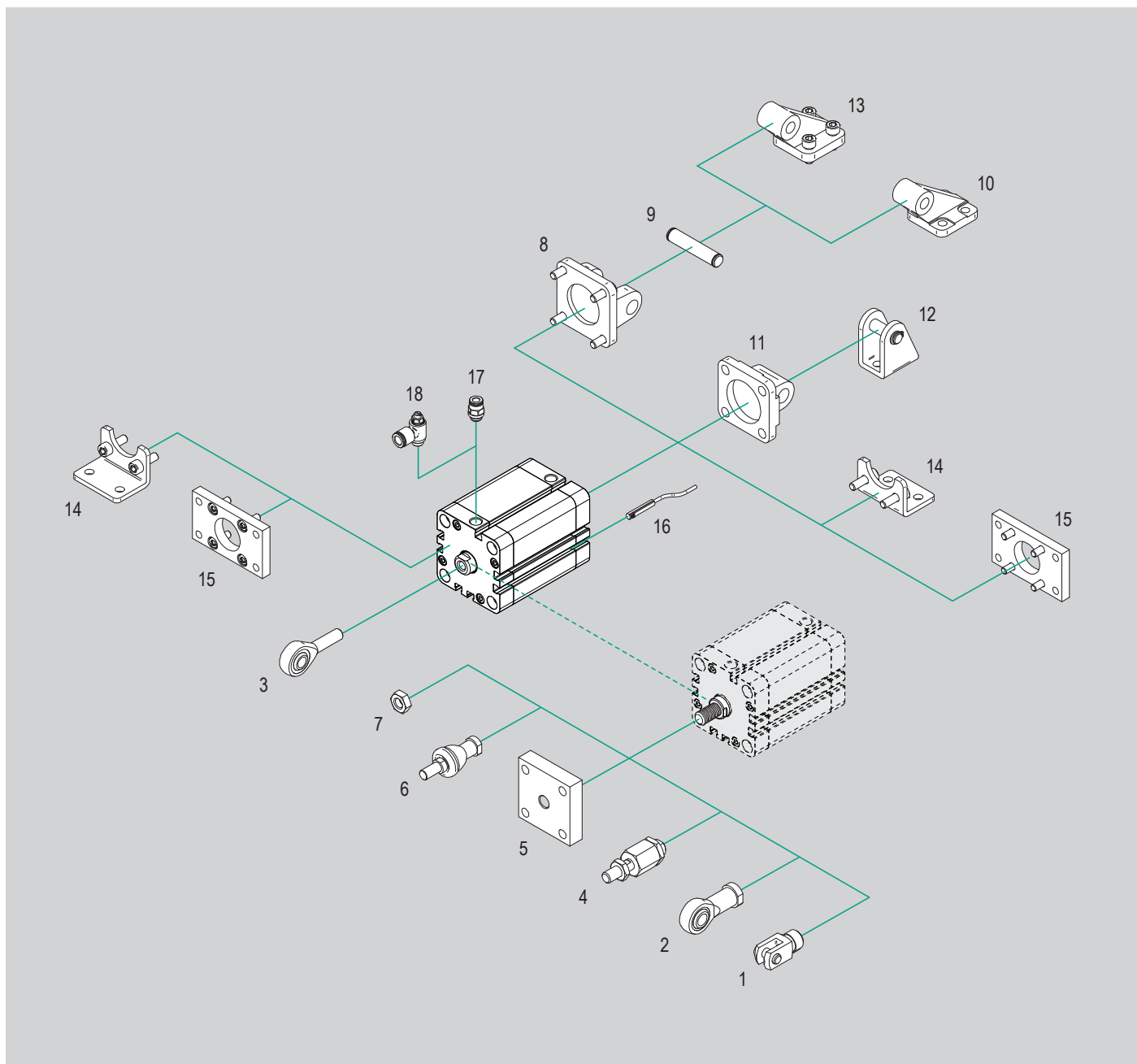

N.	Cylinder bore	Item	Description	Compliance	Matching		Code page	Data sheet page
					CS	CD		
1	Ø 12 ÷ 100	FF..ISO	ISO female clevis with clip	ISO 8140	● ⁽¹⁾	● ⁽¹⁾	1.17.90	1.85.10
	Ø 16 ÷ 100	FFP..ISO	ISO female clevis with pin and seeger		● ⁽¹⁾	● ⁽¹⁾		
	Ø 12 ÷ 100	FFN..ISO	ISO female clevis (body only)		● ⁽¹⁾	● ⁽¹⁾		
2	Ø 12 ÷ 100	RF..SE	Bearing head (DIN 648K) with female thread	ISO 8139	● ⁽¹⁾	● ⁽¹⁾	1.17.90	1.90.1
3	Ø 16 ÷ 63	RM..SE	Bearing head (DIN 648K) with male thread	DIN	●	●	1.17.90	1.90.2
	Ø 80 ÷ 100				●	●		
4	Ø 12 ÷ 100	GB..	Bearing - Self-aligning articulated coupling	-	● ⁽¹⁾	● ⁽¹⁾	1.17.91	1.90.10
5	Ø 16 ÷ 100	GC..	Self-aligning coupling		● ⁽¹⁾	● ⁽¹⁾		1.90.40
6	Ø 12 ÷ 100	RBI..	Bearing - Axial articulated coupling		● ⁽¹⁾	● ⁽¹⁾		1.90.20
		RBL..	Bearing - Angular articulated coupling	● ⁽¹⁾	● ⁽¹⁾	1.90.30		
7	Ø 12 ÷ 100	D..	Rod nut	UNI 5589	● ⁽¹⁾	● ⁽¹⁾	1.17.90	1.90.70
8	Ø 32 ÷ 100	CF..ALUN	Rear clevis	UNITOP	●	●	1.17.91	1.100.100
		CF..AQUN			●	●		1.100.150
9	Ø 32 ÷ 100	SEC..AQIS	Pin for rear clevis		●	●	1.17.92	1.98.5
10	Ø 12 ÷ 25	CM..ALUN	Rear eye	ISO MP4	●	●	1.17.91	1.100.100
	Ø 20 ÷ 25	CM..AQUN			●	●		1.100.150
11	Ø 32 ÷ 100	CM..ALIS			●	●		1.100.102
		CM..AQIS	●	●	1.100.154			
12	Ø 12 ÷ 25	CF..+P	Rear 90° hinge	ISO MP3	●	●	1.17.92	1.100.153
13	Ø 32 ÷ 100	ASV..ALIS	Rear 90° hinge	ISO AB7 CETOP RP 107P	●	●		1.100.102
		ASV..AQIS			●	●		1.100.153
14	Ø 12 ÷ 100	PB..AQUN	Low foot	UNITOP	●	●	1.17.91	1.100.152
15	Ø 12 ÷ 100	FLV..ALUN	Flange		●	●		1.100.101
		FLV..AQUN			●	●		1.100.151
16	Ø 12 ÷ 100	ASV..	Magnetic reed switch T groove	-	●	●	1.17.92	1.110.10
		MK..	ATEX magnetic reed switch T groove	2014/34/EU	●	●		1.113.1
17	Ø 12 ÷ 100	R..	Push-in fittings	-	●	●	4.2.1	
18	Ø 12 ÷ 100	V..C	Flow controls, for cylinders		●	●	4.94.1	

Key

● matching accessory; - not matching accessory

(1) Matching only with option **M**

Main features

12 ÷ 100

Bores Ø

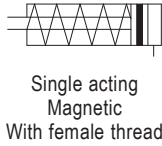

Single acting
Magnetic
With female thread

CS

Type



12 ÷ 100

Bores Ø

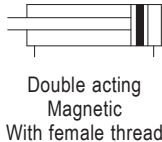

Double acting
Magnetic
With female thread

CD

Type



Technical data

Bore Ø mm	12	16	20	25	32	40	50	63	80	100	
Fluid	Filtered compressed air with or without lubrication. Lubrication, if started, must be continued.										
Pressure range	2 ÷ 10 bar										
Temperature range	-30°C ÷ +80°C (standard)					-20°C ÷ +135°C (V)					
Port	M5					1/8"			1/4"		
Grooves for switches	3						7				
Thrust force (N)*	59	110	177	270	448	700	1125	1800	2900	4510	
Spring traction force (N)*	6		7	12	16	23	30	35	60	100	
Strokes**	CS	5 ÷ 60 mm						10 ÷ 60 mm			
	CD	5 ÷ 100 mm	5 ÷ 125 mm	5 ÷ 160 mm	5 ÷ 200 mm		5 ÷ 250 mm	10 ÷ 250 mm			
Rod thread	CS-CD	M3	M4	M5	M6		M8		M10	M12	
	CSM-CDM	M6	M8	M10x1,25			M12x1,25		M16x1,5	M20x1,5	

*For cylinders CS type; **With option N, in Ø 20 maximum stroke is 125 mm

Standard strokes

Stroke mm	CS Bore Ø mm									
	12	16	20	25	32	40	50	63	80	100
5										
10										
15										
20										
25										
30										
40										
50										
60										

Stroke mm	CD Bore Ø mm									
	12	16	20	25	32	40	50	63	80	100
5										
10										
15										
20										
25										
30										
40										
50										
60										
80										
100										
125										
160										
200										
250										

Key
 Standard stroke

Standard dimensions

1 - CYLINDERS

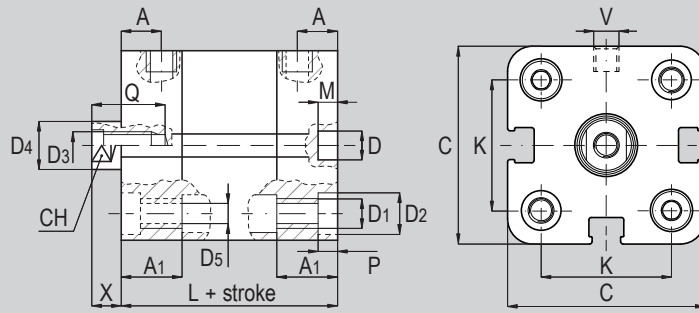

Type: **CS-CD**
Ø 12 ÷ 25

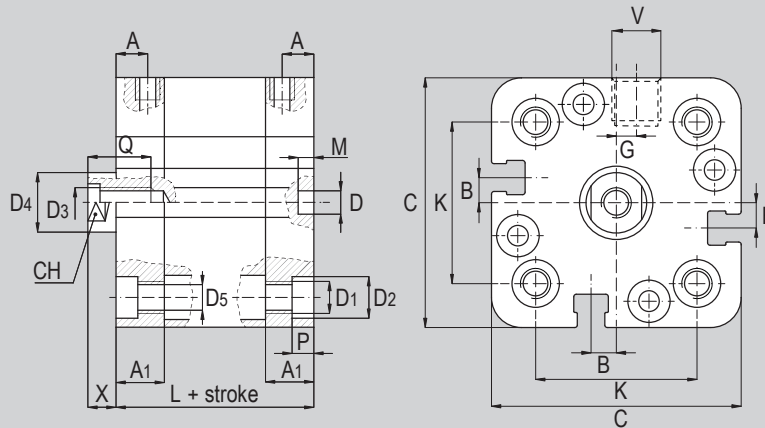

Type: **CS-CD**
Ø 32 ÷ 40

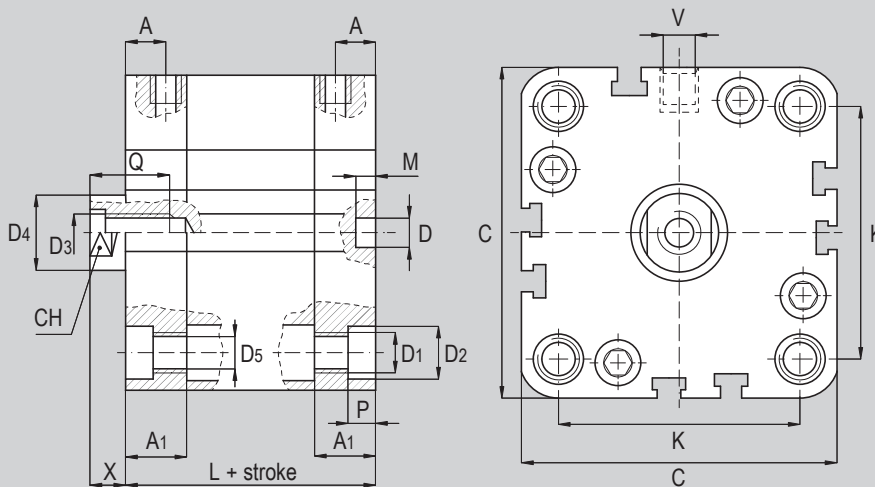

Type: **CS-CD**
Ø 50 ÷ 100

Ø (mm)	C	CH	D Ø	D ₁ Ø	D ₂ Ø	D ₃ Ø	D ₄ Ø	D ₅ Ø	G	V	A	A ₁	B	K	P	M	Q	X	L
12	29	5	6	M4	6	M3	6	3,3	-	M5	8	12,25	-	18	3,5	4	8	4,5	38 ⁽¹⁾
16	29	6	6	M4	6	M4	8	3,3	-	M5	8	12,25	-	18	3,5	4	11	4,5	38 ⁽¹⁾
20	36	8	6	M5	7,5	M5	10	4,2	-	M5	8	12,25	-	22	4,5	4	12	4,5	38 ⁽¹⁾
25	40	8	6	M5	7,5	M5	10	4,2	-	M5	8	12,75	-	26	4,5	4	12	5,5	39,5 ⁽²⁾
32	50	10	6	M6	9	M6	12	5,2	4	1/8"	8	14,5	3	32	5,5	4	15	6	44,5 ⁽²⁾
40	58	10	6	M6	9	M6	12	5,2	3	1/8"	8	14,75	5	42	5,5	4	15	6,5	45,5 ⁽²⁾
50	67	13	6	M8	10,5	M8	16	6,7	-	1/8"	8	14,75	-	50	6,5	4	17	7,5	45,5 ⁽²⁾
63	80	13	8	M10	13,5	M8	16	8,5	-	1/8"	8	14,25	-	62	8,5	4	17	7,5	50 ⁽²⁾
80	100	17	8	M10	13,5	M10	20	8,5	-	1/8"	8,5	16	-	82	8,5	4	17	8	56 ⁽³⁾
100	124	22	8	M10	13,5	M12	25	8,5	-	1/4"	10,5	19,25	-	103	8,5	4	22	10	66,5 ⁽³⁾

(1) CS type, for strokes > 30 mm, add +10 mm to dimension;
 (2) CS type, for strokes > 30 mm, add +20 mm to dimension;
 (3) CS type, for strokes > 30 mm, add +30 mm to dimension.

Dimensions with options

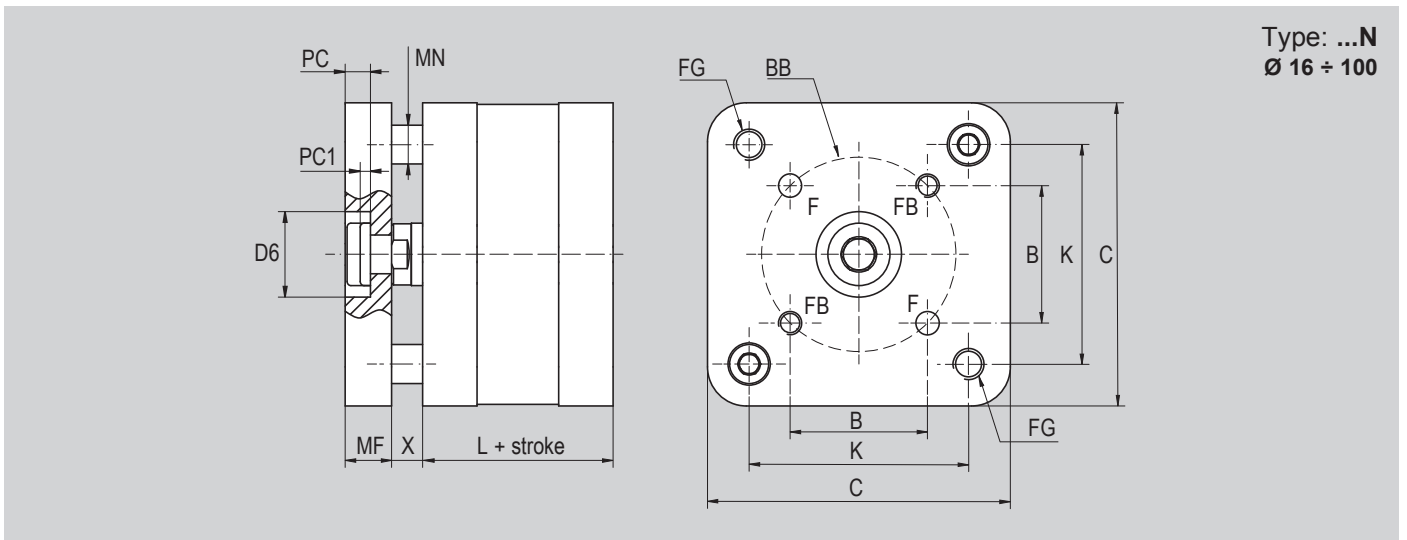
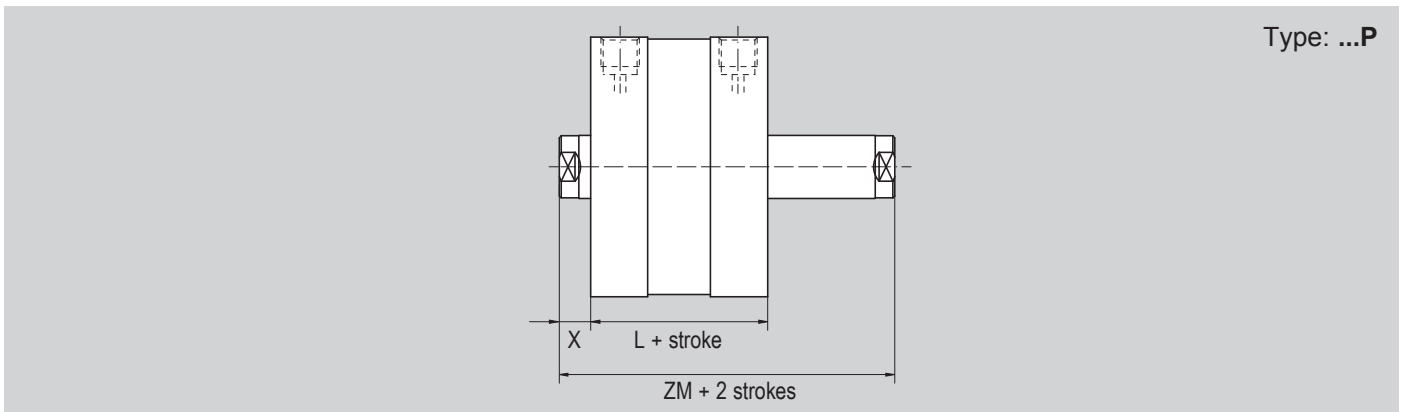
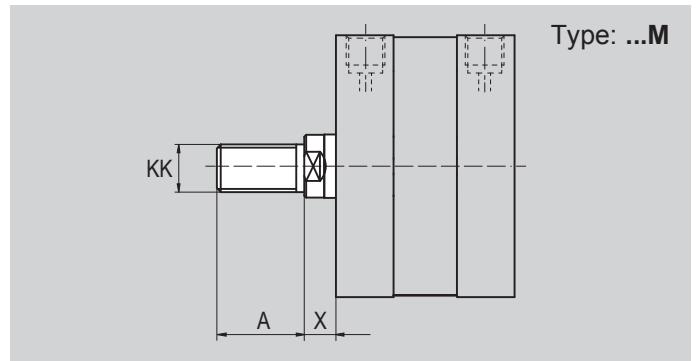
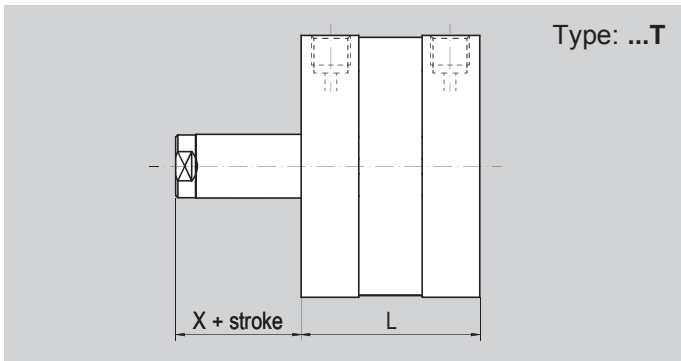

Ø (mm)	A	KK	X	L	MF +0,1	C	K	B	FG	ØBB ±0,1	ØF +0,1	FB	ZM	ØD6 h9	PC	MN f7	PC1
12	16	M6	4,5	38 ⁽¹⁾	-	-	-	-	-	-	-	-	47	-	-	-	-
16	20	M8x1.25	4,5	38 ⁽¹⁾	6	29	18	9,9	M5	14	3	M3	47	9	3,8	5	1
20	22	M10x1.25	4,5	38 ⁽¹⁾	8	36	22	12	M5	17	4	M4	47	11	5	5	1,5
25	22	M10x1.25	5,5	39,5 ⁽¹⁾	8	40	26	15,6	M5	22	5	M5	50,5	14	5	6	1,5
32	22	M10x1.25	6	44,5 ⁽¹⁾	10	50	32	19,8	M6	28	5	M5	56,5	17	6,5	8	2,5
40	22	M10x1.25	6,5	45,5 ⁽¹⁾	10	58	42	23,3	M6	33	5	M5	58,5	17	6,5	10	2,5
50	24	M12x1.25	7,5	45,5 ⁽¹⁾	12	67	50	29,7	M8	42	6	M6	60,5	22	7,5	10	2,5
63	24	M12x1.25	7,5	50 ⁽¹⁾	12	80	62	35,4	M10	50	6	M6	65	22	7,5	10	2,5
80	32	M16x1.5	8	56 ⁽²⁾	14	100	82	46	M10	65	8	M8	72	28	9	14	3
100	40	M20x1.5	10	66,5 ⁽²⁾	14	124	103	56,6	M10	80	10	M10	86,5	30	10	14	3

(1) CS type, with option T, for strokes > 30 mm, add +10 mm to dimension;
(2) CS type, with option T, for strokes > 30 mm, add +20 mm to dimension;

Female clevis with clip FF..ISO

	For cylinder Ø mm	Code	Item	Compliance
	12	041002	FF06ISO/DIN	
	16	041003	FF08ISO/DIN	
	20+40	041004	FF10ISO	
	50+63	041005	FF12ISO	
	80	041006	FF16ISO	
	100	041007	FF20ISO	

Matching with option M only

Female clevis with pin and seeger FFP..ISO

	For cylinder Ø mm	Code	Item	Compliance
	12	-	FFP06ISO/DIN	
	16	041049	FFP08ISO/DIN	
	20+40	041051	FFP10ISO	
	50+63	041040	FFP12ISO	
	80	041013	FFP16ISO	
	100	041017	FFP20ISO	

Matching with option M only

Female clevis (body only) FFN..ISO

	For cylinder Ø mm	Code	Item	Compliance
	12	041011	FFP06ISO/DIN	
	16	041018	FFP08ISO/DIN	
	20+40	041014	FFN10ISO	
	50+63	041016	FFN12ISO	
	80	041012	FFN16ISO	
	100	041015	FFN20ISO	

Matching with option M only

Rod nut D..

	For cylinder Ø mm	Code	Item	Compliance
	12	041450	D6x1	
	16	041451	D8x1,25	
	20+40	041452	D10x1,25	
	50+63	041454	D12x1,25	
	80	041455	D16x1,5	
	100	041456	D20x1,5zB	

Matching with option M only

Bearing heads (DIN 648K) with female thread RF..SE

	For cylinder Ø mm	Code	Item	Compliance
	12	041552	RF6SE	
	16	041553	RF8SE	
	20+40	041554	RF10SE	
	50+63	041555	RF12SE	
	80	041557	RF16SE	
	100	041559	RF20SE	

Matching with option M only

Bearing heads (DIN 648K) with male thread RM..SE

	For cylinder Ø mm	Code	Item	Compliance
	16	041500	RM4SE	
	20-25	041501	RM5SE	
	32-40	041502	RM6SE	
	50+63	041503	RM8SE	
	80	041550	RM10SE/M10x1,5	
	100	041514	RM12SE/M12x1,75	

Self-aligning articulated coupling GB..

	For cylinder Ø mm	Code	Item	Compliance
	12	041702	GB010	-
	16	041703	GB020	
	20+40	041704	GB040	
	50+63	041706	GB060	
	80	041708	GB100	
	100	041709	GB120	

Matching with option M only

Self-aligning coupling GC..

	For cylinder Ø mm	Code	Item	Compliance
	20+40	041722	GCM10x1,25	-
	50+63	041723	GCM12x1,25	
	80	041724	GCM16x1,5	
	100	041725	GCM20x1,5	

Matching with option M only

Axial articulated coupling RBI..

	For cylinder Ø mm	Code	Item	Compliance
	12	041602	RBI6	-
	16	041603	RBI8	
	20+40	041604	RBI10	
	50+63	041605	RBI12	
	80	041607	RBI16	
	100	041609	RBI20	

Matching with option M only

Angular articulated coupling RBL..

	For cylinder Ø mm	Code	Item	Compliance
	12	041652	RBL6	-
	16	041653	RBL8	
	20+40	041654	RBL10	
	50+63	041655	RBL12	
	80	041657	RBL16	
	100	041659	RBL20	

Matching with option M only

Rear clevis in aluminium* CF..ALUN

	For cylinder Ø mm	Code	Item	Compliance
	32	040711	CF032ALUN	UNI TOP
	40	040712	CF040ALUN	
	50	040713	CF050ALUN	
	63	040714	CF063ALUN	
	80	040715	CF080ALUN	
	100	040716	CF100ALUN	

*Available also in steel (item CF..AQUN) in Ø 32 ÷ 100, see page 1.100.150
Pin (item SEC..AQIS) to be ordered separately, see page 1.17.110
Screws to be ordered separately, see from page 1.101.40

Rear eye in aluminium* CM..ALUN

	For cylinder Ø mm	Code	Item	Compliance
	12-16	040701	CM012/016ALUN	UNI TOP
	20	040702	CM020ALUN	
	25	040703	CM025ALUN	

*Available also in steel (item CM..AQUN) in Ø 20 ÷ 25, see page 1.100.150
Screws to be ordered separately, see from page 1.101.40

Rear 90° hinge in aluminium* with screws ASV..ALIS+V

	For cylinder Ø mm	Code	Item	Compliance
	32	042081	ASV032ALIS+V	ISO AB7 cetop RP 107P
	40	042082	ASV040ALIS+V	
	50	042083	ASV050ALIS+V	
	63	042084	ASV063ALIS+V	
	80	042085	ASV080ALIS+V	
	100	042086	ASV100ALIS+V	

*Available also in steel: item CF..+P for Ø 12 ÷ 25 and item ASV..AQIS for Ø 32 ÷ 100, see page 1.100.153

Rear eye in aluminium* with screws CM..ALIS+V

	For cylinder Ø mm	Code	Item	Compliance
	32	042061	CM032ALIS+V	ISO MP4
	40	042062	CM040ALIS+V	
	50	042063	CM050ALIS+V	
	63	042064	CM063ALIS+V	
	80	042065	CM080ALIS+V	
	100	042066	CM100ALIS+V	

*Available also in steel (item CM..AQIS+V) in Ø 32 ÷ 100, see page 1.100.154

Flange in aluminium FL..ALUN

	For cylinder Ø mm	Code	Item	Compliance
	12-16	040721	FL012/016ALUN	UNI TOP
	20	040722	FL020ALUN	
	25	040723	FL025ALUN	
	32	040724	FL032ALUN	
	40	040725	FL040ALUN	
	50	040726	FL050ALUN	
	63	040727	FL063ALUN	
	80	040728	FL080ALUN	
100	040729	FL100ALUN		



Screws to be ordered separately, see from page 1.101.40

Flange in steel FL..AQUN

	For cylinder Ø mm	Code	Item	Compliance
	12-16	040751	FL012016AQUN	UNI TOP
	20	040752	FL020AQUN	
	25	040753	FL025AQUN	
	32	040754	FL032AQUN	
	40	040755	FL040AQUN	
	50	040756	FL050AQUN	
	63	040757	FL063AQUN	
	80	040758	FL080AQUN	
100	040759	FL100AQUN		

Screws to be ordered separately, see from page 1.101.40



Low foot* in steel PB..AQUN

	For cylinder Ø mm	Code	Item	Compliance
	12-16	040761	PB012/016AQUN	
	20	040762	PB20AQUN	
	25	040763	PB25AQUN	
	32	040764	PB32AQUN	

*Supplied individually.

Screws to be ordered separately, see from page 1.101.40



Low foot* in steel PB..AQUN

	For cylinder Ø mm	Code	Item	Compliance
	40	040765	PB040AQUN	
	50	040766	PB050AQUN	
	63	040767	PB063AQUN	
	80	040768	PB080AQUN	
	100	040769	PB100AQUN	

*Supplied individually.



Screws to be ordered separately, see from page 1.101.40

Pin with seeger in steel SEC..AQIS



	For cylinder Ø mm	Code	Item	Compliance
	32	040261	SEC032AQIS	
	40	040262	SEC040AQIS	
	50	040263	SEC050AQIS	
	63	040264	SEC063AQIS	
	80	040265	SEC080AQIS	
100	040266	SEC100AQIS		

*Supplied with 2 seeger

Magnetic reed switch T groove ASV..

	For cylinder Ø mm	Code	Item	Cylinder matching
	12 ÷ 100	070946 	ASV1C525	CS CD
		071863	ASV1C550	
		071864	ASV1C51K	
		071189	ASV1C5M8	
		073639	ASV4D225	
		070246 	ASV4D2M8	
		074900	ASV7N225	
		070247	ASV7N2M8	
		070372	ASV7M2M8	
072918		ASV1H525		

ATEX magnetic reed switch T groove MK..

	For cylinder Ø mm	Code	Item	Compliance	Cylinder matching
	12 ÷ 100	071120	MK500A		CS CD
		071108	MK502A		

COMPACT

Cylinders



Find out our
key products



Solution for most applications



Easy and intuitive choice



Excellent value for money



Wide availability



Fast delivery



Features and certifications

Series of compact cylinders not conforming to standards, available in bores from Ø 6 to 32, double acting, magnetic or non magnetic. The barrel with grooves allows the magnetic versions to mount magnetic reed switches directly in the tube.
Supplied as standard in compliance with Reach and RoHS directives.



Type DU Ø 16 ÷ 32

from page 1.18.20



Compact cylinders not conforming to standards, available in bores from Ø 16 to 32, double acting, non magnetic.

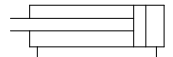

Type DUM Ø 6 ÷ 32

from page 1.18.20



Compact cylinders not conforming to standards, available in bores from Ø 16 to 32, double acting, magnetic.
The barrel with grooves allows mounting magnetic reed switches directly.

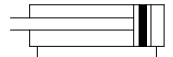

Options		
Description	Symbol	Suffix
Anti-rotating plate (available from Ø 16)		N
Special versions on request		/S

The options, when this is possible, can be combined with each other. For options matching and code key, see the tables below.

Options matching			
Series	Bore	Model	Standard options matching
			N (Ø16÷32)
DU	Ø 6 ÷ 32	Standard	●
	Ø 16 ÷ 32	Anti-rotating plate (N)	
DUM	Ø 6 ÷ 32	Standard	●
	Ø 16 ÷ 32	Anti-rotating plate (N)	

Key
 ● allowed matching; - not allowed matching

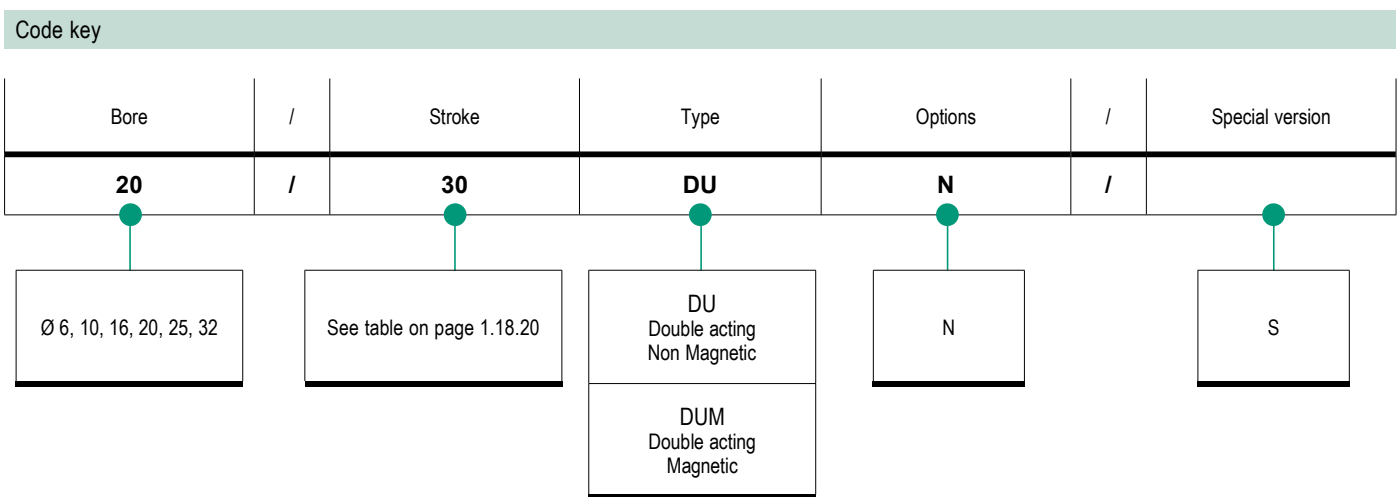

How to order

Bore	Stroke	Type	Options
20	/	30	DU
		N	

Notes

For further information on options and their matching, see tables above.

Standard materials

1 - CYLINDERS

Type: **DU**

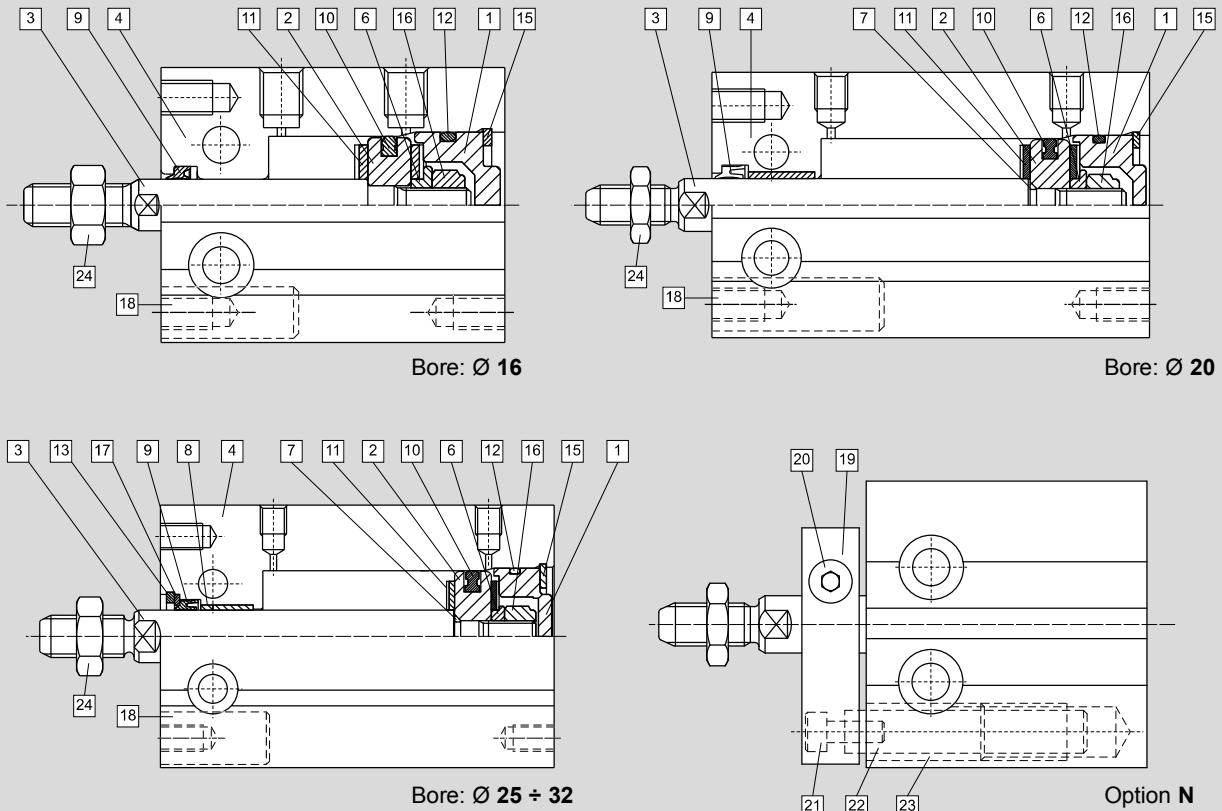

Position	Description	Materials					
		Ø 6	Ø 10	Ø 16	Ø 20	Ø 25	Ø 32
1	End cover	Hard anodised aluminium					
2	Piston	Brass		Hard anodised aluminium			
3	Rod	Stainless Steel			Carbon steel		
4	Tube	Hard anodised aluminium					
5	Magnet holder	Hard anodised aluminium					
6	T-washer	Nickel-plated carbon steel					
7	O-ring	NBR					
8	Oilless bearing	Oil-impregnated sintered alloy					
9	Rod packing	Polyurethane (PU)			NBR		
10	Piston seal	NBR					
11	Rubber lining	NBR					
12	Cylinder gasket	NBR					
13	Retaining ring	Nickel-plated carbon steel					
14	Magnet	Magnetic material					
15	Retaining ring	Nickel-plated carbon steel					
16	Piston nut	Galvanized carbon steel					
17	Rod washer	Stainless Steel					
18	Screw plug	Hard anodised aluminium					
19	Guide plate	Hard anodised aluminium					
20	Screw	Nickel-plated carbon steel					
21	Screw	Nickel-plated carbon steel					
22	Guide rod	Carbon steel					
23	Oilless bearing	Oil-impregnated sintered alloy					
24	Rod and nut	Stainless Steel			Nickel-plated carbon steel		

Type: **DUM**

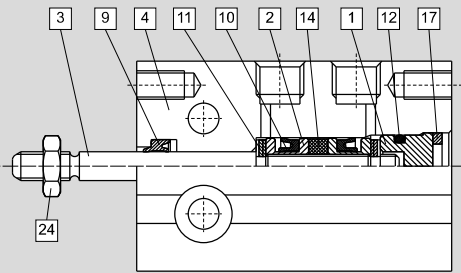

Bore: \varnothing 6

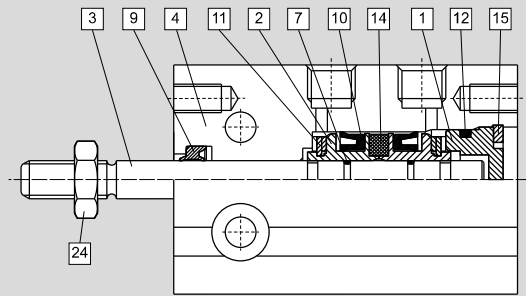

Bore: \varnothing 10

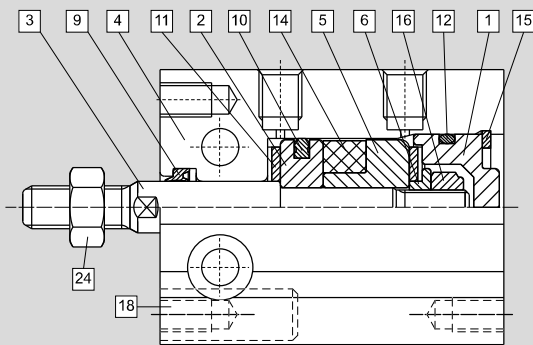

Bore: \varnothing 16

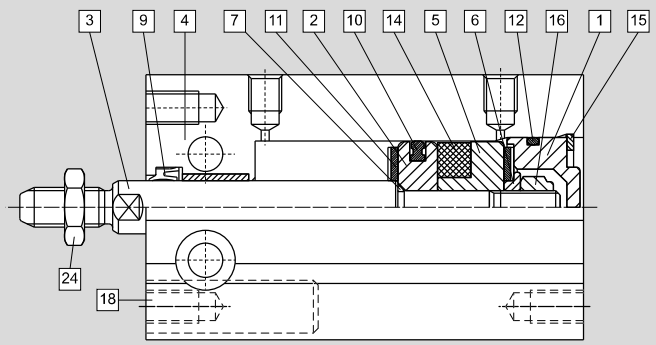

Bore: \varnothing 20

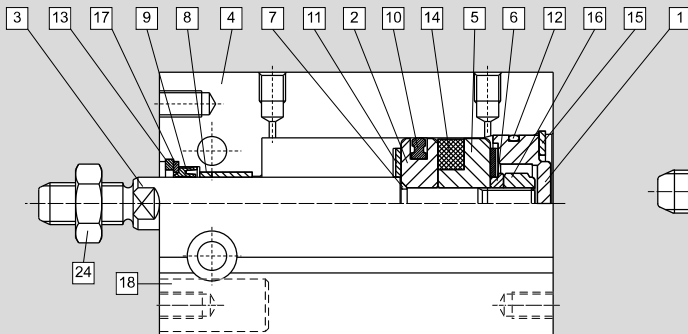

Bore: \varnothing 25 ÷ 32

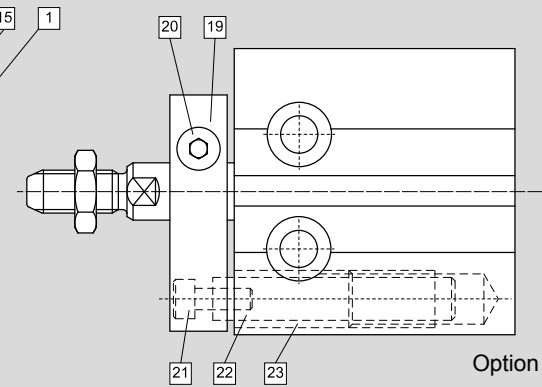

Option N

Accessories

1 - CYLINDERS

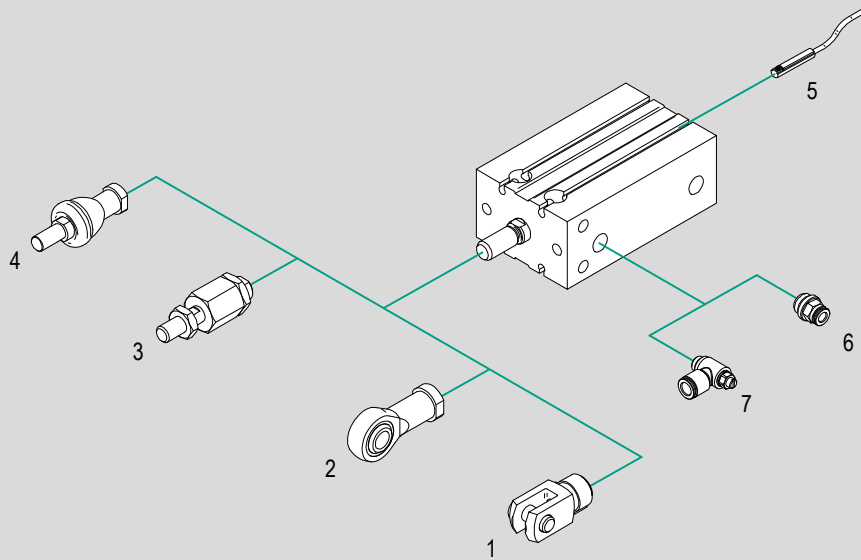

N.	Cylinder bore	Item	Description	Compliance	Matching		Code page	Data sheet page
					DU	DUM		
1	Ø 10 ÷ 32	FF..DIN	DIN female clevis with clip	DIN 71752 UNI 1676	●	●	1.18.90	1.86.1
		FFP..DIN	DIN female clevis with pin and seeger		●	●		
		FFN..DIN	DIN female clevis (body only)		●	●		1.86.2
2	Ø 20 ÷ 32	RF..SE	Bearing head (DIN 648K) with female thread	ISO 8139	●	●	1.18.90	1.90.1
3	Ø 10 ÷ 32	GB..	Bearing - Self-aligning articulated coupling	-	●	●		1.90.10
4	Ø 16 ÷ 32	RBI..	Bearing - Axial articulated coupling		●	●		1.90.20
	Ø 16 ÷ 25	RBL..	Bearing - Angular articulated coupling		●	●	1.90.30	
5	Ø 6 ÷ 32	ASC..	Magnetic reed switch C groove	-	-	●	4.2.1	1.110.30
6	Ø 6 ÷ 32	R..	Push-in fittings		●	●		
7	Ø 6 ÷ 32	V..C	Flow controls, for cylinders		●	●		4.94.1

Key

● matching accessory; - not matching accessory

Main features

16 ÷ 32

Bores Ø

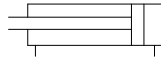

Double acting
Non magnetic

DU

Type



6 ÷ 32

Bores Ø

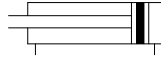

Double acting
Magnetic

DUM

Type



Technical data

Bore Ø mm	6	10	16	20	25	32	
Fluid	Filtered compressed air with or without lubrication. Lubrication, if started, must be continued.						
Pressure range	3 ÷ 7 bar	1,5 ÷ 7 bar		1 ÷ 7 bar			
Temperature range	-10°C ÷ +60°C						
Port	M5					1/8"	
Strokes	DU	-		5 ÷ 30 mm	5 ÷ 50 mm		
	DUM	5 ÷ 30 mm			5 ÷ 50 mm		
Rod thread	DU	-		M5	M6	M8	M10
	DUM	M3	M4	M5	M6	M8	M10

Standard strokes

Stroke mm	DU Bore Ø mm			
	16	20	25	32
5				
10				
15				
20				
25				
30				
40				
50				

Stroke mm	DUM Bore Ø mm					
	6	10	16	20	25	32
5						
10						
15						
20						
25						
30						
40						
50						

Key
 Standard stroke

Standard dimensions

1 - CYLINDERS

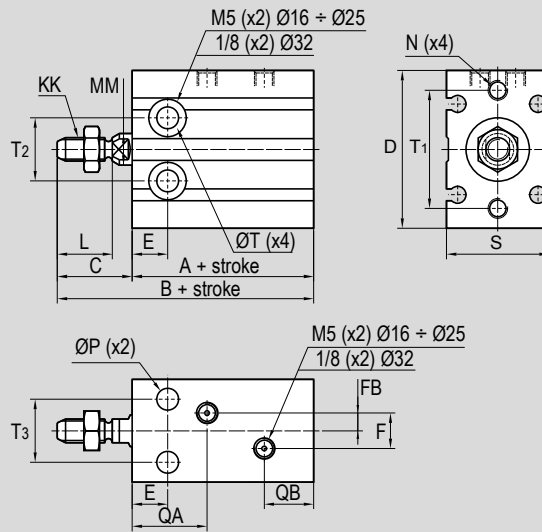

Type: **DU**
Ø 16 ÷ 32

Ø (mm)	A	B	C	D	E	F	FB	L	KK	ØMM	N	ØP	QA	QB	S	T	T ₁	T ₂	T ₃
16	30	46	16	32	7	4	2	12,5	M5	6	M4	4,3	14	11,5	20	Ø 7,6 depth 6,5	25	14	12
20	36	55	19	40	9	9	4,5	14	M6	8	M5	5,2	18	12,5	26	Ø 9 depth 7,6	30	16	16
25	40	63	23	50	10	9	4,5	18	M8	10	M5	5,5	21,5	12,5	32	Ø 9,5 depth 9	38	20	20
32	42	69	27	62	11	13,5	4,5	22	M10	12	M6	6,6	23	13	40	Ø 11 depth 11	48	24	24

Standard dimensions

Type: **DUM**
Ø 6 ÷ 10

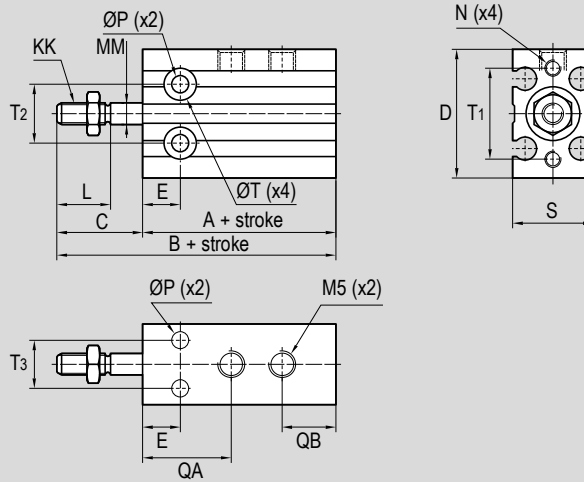

Ø (mm)	A	B	C	D	E	L	KK	ØMM	N	ØP	QA	QB	S	T	T ₁	T ₂	T ₃
6	33	46	13	22	7	7	M3	3	M3	3,2	15	10	13	Ø 6 depth 4.8	17	10	7
10	36	52	16	24	7	10	M4	4	M3	3,2	15	11	18	Ø 6 depth 5	17	10	7

Standard dimensions

Type: **DUM**
Ø 16 ÷ 32

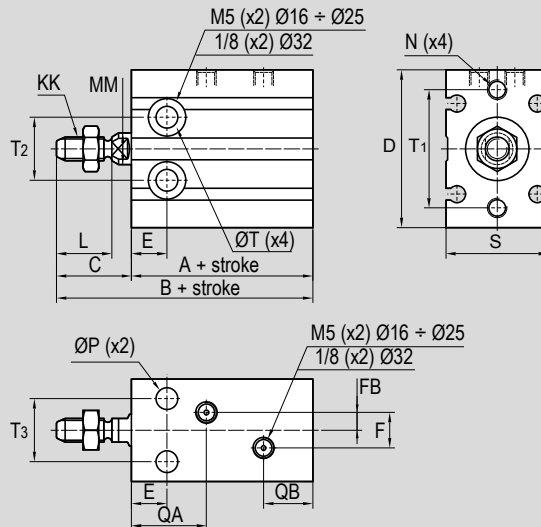

Ø (mm)	A	B	C	D	E	F	FB	L	KK	ØMM	N	ØP	QA	QB	S	T	T ₁	T ₂	T ₃
16	40	56	16	32	7	4	2	12,5	M5	6	M4	4,3	14	11,5	20	Ø 7,6 depth 6,5	25	14	12
20	46	65	19	40	9	9	4,5	14	M6	8	M5	5,2	18	12,5	26	Ø 9 depth 7,6	30	16	16
25	50	73	23	50	10	9	4,5	18	M8	10	M5	5,5	21,5	12,5	32	Ø 9,5 depth 9	38	20	20
32	52	79	27	62	11	13,5	4,5	22	M10	12	M6	6,6	23	13	40	Ø 11 depth 11	48	24	24

Dimensions with options

1 - CYLINDERS

Type: ...N
Ø 16 ÷ 32

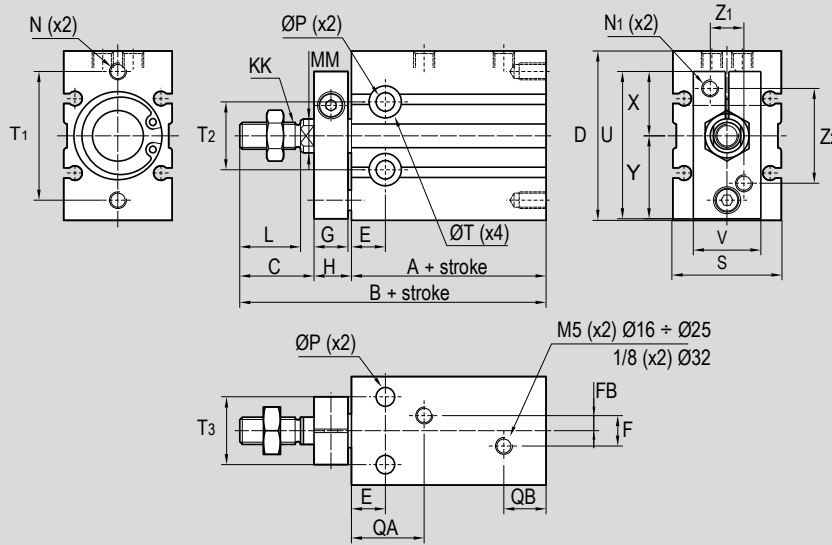

Ø (mm)	A		B		C	D	E	F	FB	G	H	L	KK	ØMM	N	N ₁	ØP
	DU	DUM	DU	DUM													
16	30	40	56	66	17	32	7	4	2	8	9	12,5	M5	6	M4	M4	4,3
20	36	46	65	75	20	40	9	9	4,5	8	9	14	M6	8	M5	M4	5,2
25	40	50	73	83	22	50	10	9	4,5	10	11	18	M8	10	M5	M5	5,5
32	42	52	84	94	29	62	11	13,5	4,5	12	13	22	M10	12	M6	M5	6,5

Ø (mm)	T	T ₁	T ₂	T ₃	QA	QB	S	U	V	X	Y	Z ₁	Z ₂
16	Ø 7,6 depth 6,5	25	14	12	14	11,5	20	28	13	12,5	15,5	6	18
20	Ø 9 depth 7,6	30	16	16	18	12,5	26	33	16	13,5	19,5	8	20
25	Ø 9,5 depth 9	38	20	20	21,5	12,5	32	43,5	20	19	24,5	10	28
32	Ø 11 depth 11	48	24	24	23	13	40	51,5	24	21	30,5	12	32

Female clevis with clip FF..DIN

	For cylinder Ø mm	Code	Item	Compliance
	6	-	-	DIN 71752
	10	041001	FF04ISO/DIN	
	16	041022	FF05DIN	UNI 1676
	20	041002	FF06ISO/DIN	
	25	041003	FF08ISO/DIN	
	32	041025	FF10DIN	

Female clevis with pin and seeger FFP..DIN

	For cylinder Ø mm	Code	Item	Compliance
	6	-	-	DIN 71752
	10	-	FFP04DIN	
	16	-	FFP05DIN	UNI 1676
	20	-	FFP06DIN	
	25	-	FFP08DIN	
	32	041096	FFP10DIN	

Female clevis (body only) FFN..DIN

	For cylinder Ø mm	Code	Item	Compliance
	6	-	-	DIN 71752
	10	041091	FFN04DIN	
	16	-	-	UNI 1676
	20	041011	FFN06DIN	
	25	041018	FFN08DIN	
	32	041020	FFN10DIN	

Bearing heads (DIN 648K) with female thread RF..SE

	For cylinder Ø mm	Code	Item	Compliance
	6	-	-	ISO 8139
	10	-	-	
	16	-	-	
	20	041552	RF6SE	
	25	041553	RF8SE	
	32	041565	RF10x1,5SE	

Self-aligning articulated coupling GB..

	For cylinder Ø mm	Code	Item	Compliance
	10	041701	GB008	-
	16	041700	GB005	
	20	041702	GB010	
	25	041703	GB020	
	32	041704	GB050	

Axial articulated coupling RBL..

	For cylinder Ø mm	Code	Item	Compliance
	16	041601	RBI5	-
	20	041602	RBI6	
	25	041603	RBI8	
	32	041611	RBI10x1,5	

Angular articulated coupling RBL..

	For cylinder Ø mm	Code	Item	Compliance
	16	041651	RBL5	-
	20	041652	RBL6	
	25	041653	RBL8	

Magnetic reed switch C groove ASC..

	For cylinder Ø mm	Code	Item	Cylinder matching
	6 ÷ 32	070248	ASC1C525	DUM
		070249	ASC7N2M8	
		070382	ASC7M2M8	

SHORT STROKE

Cylinders



Find out our
key products



Solution for most applications



Easy and intuitive choice



Excellent value for money



Wide availability



Fast delivery



Features and certifications

Series of short stroke cylinders, available in bores from Ø 12 to 100, single acting or double acting, magnetic or non magnetic, with female thread. Up to bore Ø 100 with extruded aluminium profile barrel allowing the direct mounting of magnetic reed switches, and built-in mounting holes. Supplied as standard in compliance with Reach and RoHS directives, and SIL certificated. On request, they can be also supplied according to the 2014/34/EU ATEX Directive.



Type BS Ø 12 ÷ 100

from page 1.20.20



Short stroke cylinders, available in bores from Ø 12 to 100, single acting, non magnetic, with female thread.
Mounting holes are built-in the barrel.

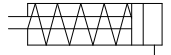

Type BSM Ø 12 ÷ 100

from page 1.20.20



Short stroke cylinders, available in bores from Ø 12 to 100, single acting, magnetic, with female thread and elastic dampers on the heads.
Barrell present built-in mounting holes and grooves allowing the mounting of magnetic reed switches (with bracket to be ordered separately).

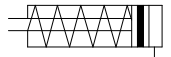

Type BD Ø 12 ÷ 100

from page 1.20.40



Short stroke cylinders, available in bores from Ø 12 to 100, double acting, non magnetic, with female thread.
Mounting holes are built-in the barrel.

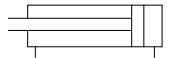

Type BDM Ø 12 ÷ 100

from page 1.20.40



Short stroke cylinders, available in bores from Ø 12 to 100, double acting, magnetic, with female thread and elastic dampers on the heads.
Barrell present built-in mounting holes and grooves allowing the mounting of magnetic reed switches (with bracket to be ordered separately).

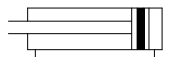

Options		
Description	Symbol	Suffix
Anti-rotating plate (available only for type BDM from Ø 20 to 100)		N
Rear spring (available only for type BS e BSM, from Ø 12 to 63)		T
Through rod (available from Ø 16 to 100)		P
FKM seals (available from Ø 16 to 100)	-20°C ÷ +150°C 	V
Stainless steel seeger for front head (from Ø 25 to 100)		SGX
ATEX versions on request		/ATEX
Special versions on request		/S

The options, when this is possible, can be combined with each other. For options matching see from page 1.20.4; For code key see from page 1.20.5

Options matching

Series	Bore	Model	Standard options matching					
			N (Ø20+100)	T (Ø12+63)	P (Ø16+100)	V (Ø16+100)	SGX (Ø25+100)	/ATEX
BS-BSM	Ø 12 ÷ 100	Standard	-	●	-	●	●	●
	Ø 12 ÷ 63	Rear spring (T)	-		-	●	●	●
BD	Ø 12 ÷ 100	Standard	●	-	●	●	●	●
	Ø 16 ÷ 100	Through rod (P)	●	-		●	●	●
BDM	Ø 12 ÷ 100	Standard	●	-	●	●	●	●
	Ø 20 ÷ 100	Anti-rotating plate (N)		-	●	●	●	●
	Ø 16 ÷ 100	Through rod (P)	●	-		●	●	●

Key

● allowed matching; - not allowed matching

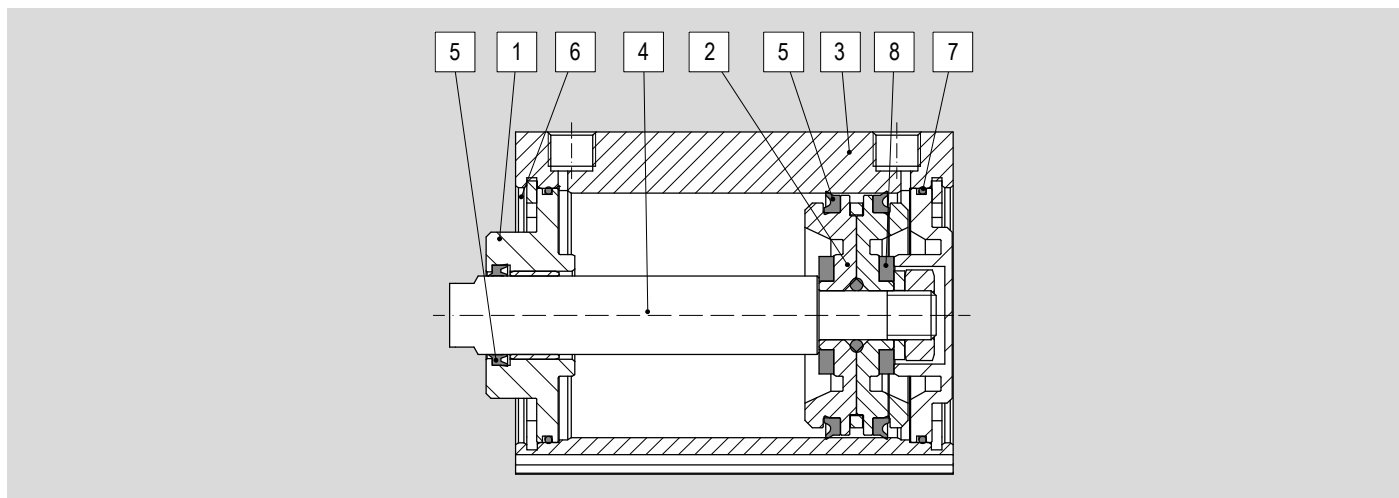
Standard materials

Position	Description	Materials										
		Ø 12	Ø 16	Ø 20	Ø 25	Ø 32	Ø 40	Ø 50	Ø 63	Ø 80	Ø 100	
1	End cover	Brass					Aluminium					
2	Semi-piston	Magnetic	Acetalic resin (POM)							Aluminium		
		Non magnetic	Acetalic resin (POM)					Aluminium				
3	Tube	Anodised aluminium										
4	Rod	Stainless Steel AISI 303										
5	Rod seal	Polyurethane (PU)										
6	Seeger	Steel										
7	Seals	NBR										
8	Elastic dampers	NBR										

Code key

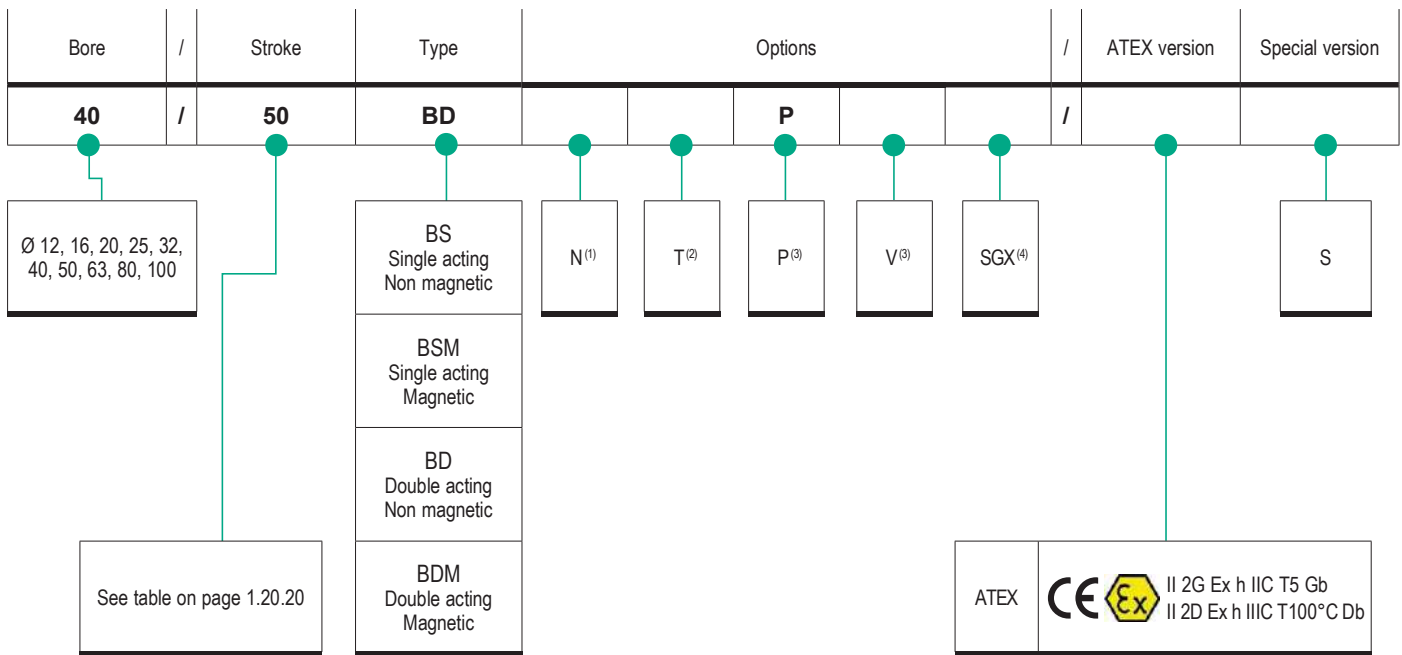

How to order

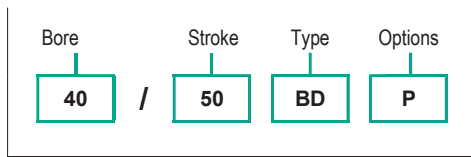

Notes

Options in the same grid are alternative to each others.
 For further information on options and their matching, see page 1.20.3 and page 1.20.4

- (1) Available only for types BD and BDM from Ø 25 to 100
- (2) Available only for types BS and BSM from Ø 12 to 63
- (3) Available from Ø 16 to 100
- (4) Available from Ø 25 to 100

For further information on the ATEX 2014/34/EU Directive, on classifications and protections, see from page III.1

Seal kit standard*

Number of components	Description
n. 1	Rod seal
n. 2	Barrell o-ring
n. 1	Semipiston o-ring
n. 2	Piston seal
n. 2	Elastic dampers

Standard seal kit code key

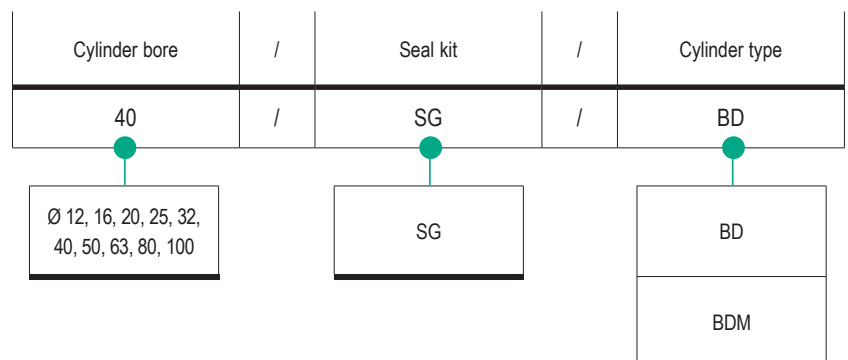

*For cylinders with options P or V, the kit include further components.

Accessories

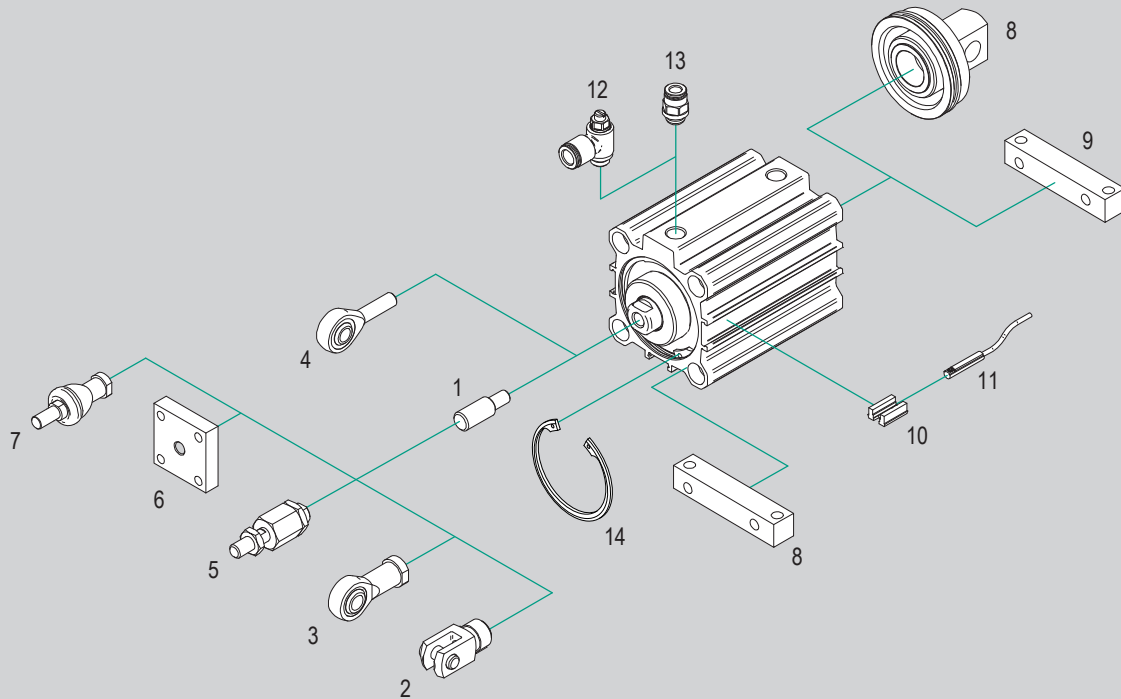

N.	Cylinder bore	Item	Description	Compliance	Matching		Code page	Data sheet page	
					BS-BD	BSM-BDM			
1	Ø 12 ÷ 100	N..AQB	Rod nipple	-	●	●	1.20.90	1.90.60	
2	Ø 12 ÷ 100	FF..ISO	ISO female clevis with clip	ISO 8140	● ⁽¹⁾	● ⁽¹⁾		1.85.10	
	Ø 32 ÷ 100	FFP..ISO	ISO female clevis with pin and seeger		● ⁽¹⁾	● ⁽¹⁾		1.85.11	
	Ø 12 ÷ 100	FFN..ISO	ISO female clevis (body only)		● ⁽¹⁾	● ⁽¹⁾		1.90.1	
3	Ø 12 ÷ 100	RF..SE	Bearing head (DIN 648K) with female thread	ISO 8139	● ⁽¹⁾	● ⁽¹⁾		1.90.2	
4	Ø 16 ÷ 63	RM..SE	Bearing head (DIN 648K) with male thread	ISO 8139	●	●		1.20.91	1.90.10
	Ø 80 ÷ 100			DIN	●	●			
5	Ø 12 ÷ 100	GB..	Bearing - Self-aligning articulated coupling	-	● ⁽¹⁾	● ⁽¹⁾		1.90.40	
6	Ø 32 ÷ 100	GC..	Self-aligning coupling		● ⁽¹⁾	● ⁽¹⁾		1.90.20	
7	Ø 12 ÷ 100	RBL..	Bearing - Axial articulated coupling		● ⁽¹⁾	● ⁽¹⁾		1.90.30	
		RBL..	Bearing - Angular articulated coupling		● ⁽¹⁾	● ⁽¹⁾		1.100.201	
8	Ø 16 ÷ 100	CM..ALB	Back head with integrated rear eye		● ⁽²⁾	● ⁽²⁾		1.100.200	
9	Ø 16 ÷ 100	P..ALB	High foot		●	●		1.120.2	
10	Ø 12 ÷ 100	AS108	Bracket for reed switches type "T"		-	●		1.110.10	
11	Ø 12 ÷ 100	ASV..	Magnetic reed switch T groove		-	●	1.113.1		
		MK..	ATEX magnetic reed switch T groove		2014/34/EU	-	●		
12	Ø 12 ÷ 100	R..	Push-in fittings		-	●	●	4.2.1	
13	Ø 12 ÷ 100	V..C	Flow controls, for cylinders		-	●	●	4.94.1	
14	Ø 25 ÷ 100	SGX..	Stainless steel seeger for front head		-	●	●	1.20.91	-

Key

● matching accessory; - not matching accessory

(1) Matching only with rod nipple N..AQB mounted

(2) Accessory to be ordered with the cylinder

Short Stroke Cylinders

Series BS - BSM



Main features

12 ÷ 100

Bores Ø

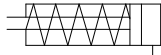

Single acting
Non magnetic
With female thread

BS

Type



12 ÷ 100

Bores Ø

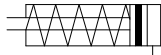

Single acting
Magnetic
With female thread

BSM

Type



Technical data

Bore Ø mm	12	16	20	25	32	40	50	63	80	100
Fluid	Filtered compressed air with or without lubrication. Lubrication, if started, must be continued.									
Pressure range	2 ÷ 10 bar									
Temperature range	-20°C ÷ +80°C (standard)					-20°C ÷ +150°C (V)				
Port	M5				1/8"				1/4"	
Thrust force (N)	51	106	170	258	441	729	1070	1720	2880	4400
Spring traction force (N)	5	6		13	18	20	40	49	76	131
Strokes*	5 ÷ 25 mm				5 ÷ 50 mm					
Rod thread	M3	M4	M5		M6		M8		M10	M12

*In case of intermediate strokes from the standard strokes (see table below), the cylinder body will have the overall dimensions of the cylinder with the next standard stroke, as desired stroke is obtained by applying a spacer.

Standard strokes

Stroke mm	BS Bore Ø mm									
	12	16	20	25	32	40	50	63	80	100
5										
10										
15										
20										
25										
30										
40										
50										

Stroke mm	BSM Bore Ø mm									
	12	16	20	25	32	40	50	63	80	100
5										
10										
15										
20										
25										
30										
40										
50										

Key
 Standard stroke

Standard dimensions

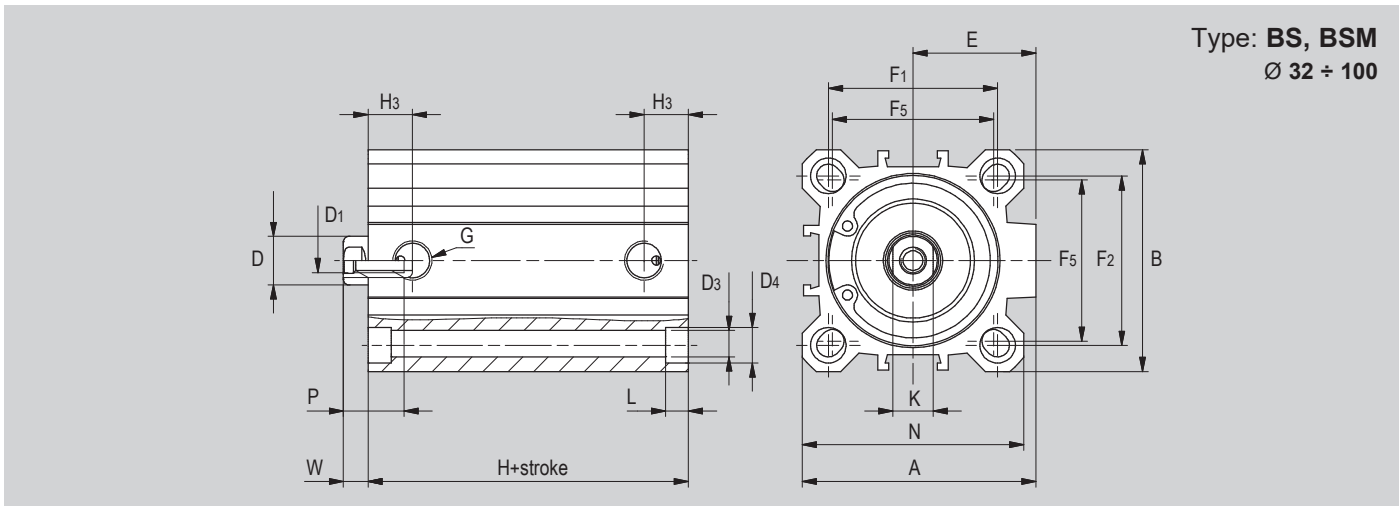
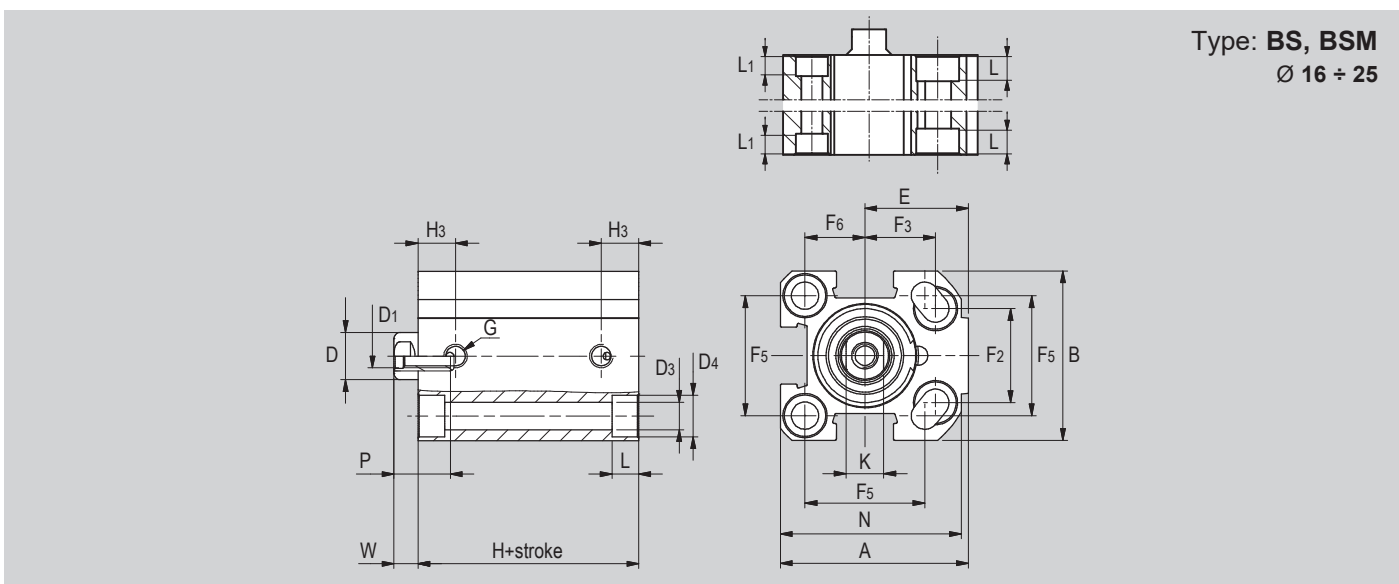
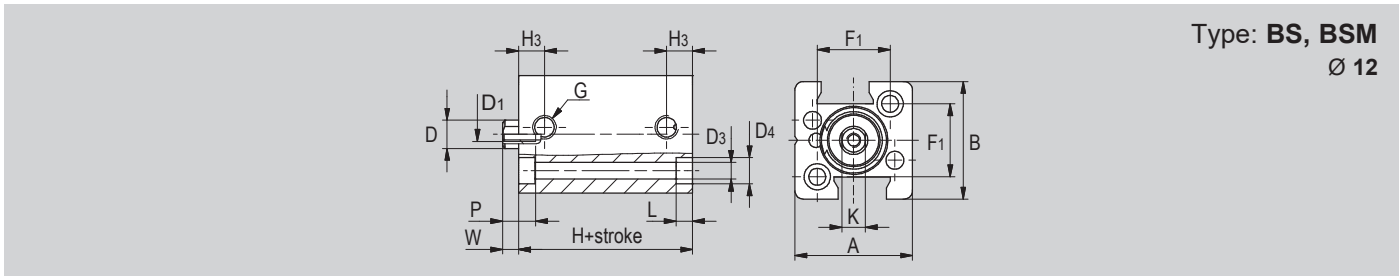

Ø (mm)	A	B	ØD	D ₁	ØD ₃	ØD ₄	E	G	H		H ₃	F ₁	F ₂	F ₃	F ₅	F ₆	K	L	L ₁	N	P	W
									type BS	type BSM												
12	25	25	6	M3	3,7	5,6	-	M5	17 ⁽¹⁾	27	5,5	15,5	-	-	-	-	5	3,5	-	-	7	3,5
16	34	30	8	M4	4,7	7,5	19	M5	27	32 ⁽³⁾	8	-	18	12	20	10	6	4,6	3,5	32	11	4,5
20	40	36	10	M5	5,8	9	22	M5	27	32 ⁽³⁾	8	-	20	15	25,5	12,7	8	5,7	5,7	38,5	12	5
25	44,5	40	10	M5	5,8	9	24,5	1/8"	28,5	38,5 ⁽⁴⁾	10,5 ⁽⁶⁾	-	26	15,5	28	14	8	5,7	5,7	42	12	5,5
32	51	46	12	M6	5,8	9	27	1/8"	29,5 ⁽²⁾	39,5 ⁽⁵⁾	11,5 ⁽⁷⁾	36	32	-	34	-	10	5,7	-	48	15	6
40	58	55	12	M6	5,8	9	30,5	1/8"	29,5 ⁽²⁾	39,5 ⁽⁵⁾	11 ⁽⁷⁾	42	42	-	40	-	10	5,7	-	55	15	6
50	70	65	16	M8	6,8	11	37,5	1/8"	34,5 ⁽²⁾	39,5 ⁽⁵⁾	11,5	50	50	-	50	-	13	6,8	-	65	17	7,5
63	89	80	16	M8	9	14	46	1/8"	37 ⁽²⁾	42 ⁽³⁾	11	62	62	-	60	-	13	8,8	-	80	17	7
80	105	100	20	M10	9	14	55	1/4"	46 ⁽²⁾	46 ⁽³⁾	14	82	82	-	77	-	17	9	-	100	17	8
100	131	124	25	M12	11	17,2	69	1/4"	56 ⁽²⁾	56 ⁽³⁾	16	103	103	-	94	-	22	11	-	124	22	10

(1) For strokes 15, 20 and 25 mm, add +5 mm to dimension; (2) For strokes 40 and 50 mm, add +10 mm to dimension; (3) For stroke 25 mm, add +6 mm to dimension; (4) For strokes 25 mm, add +1 mm to dimension; (5) For strokes 40 and 50 mm, add +10 mm to dimension; (6) If quote H is less than 38,5 the dimension is 8,5; (7) If quote H is less than 39,5 the dimension is 8.

Dimensions with options

1 - CYLINDERS

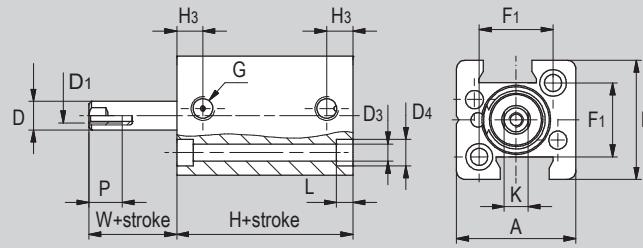

Type: ...T
Ø 12

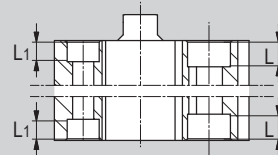

Type: ...T
Ø 16 ÷ 25

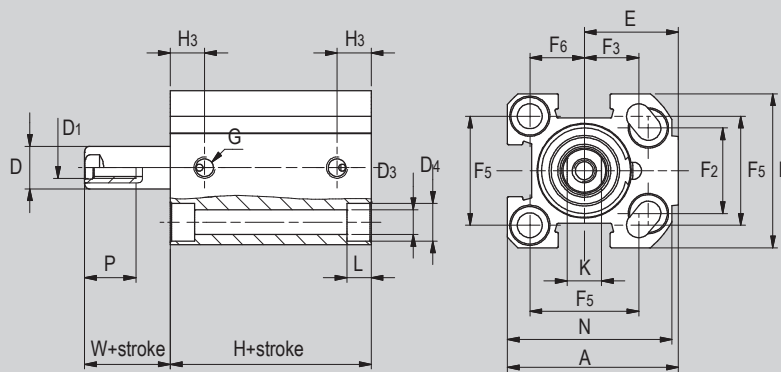

Type: ...T
Ø 32 ÷ 63

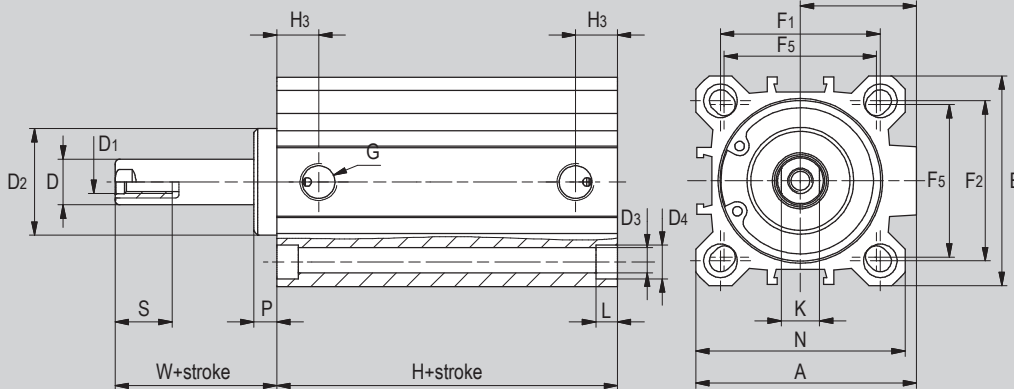

Ø (mm)	A	B	ØD	D ₁	ØD ₂	ØD ₃	ØD ₄	E	G	H	H ₃	F ₁	F ₂	F ₃	F ₅	F ₆	K	L	L ₁	N	P	S	W
12	25	25	6	M3	-	3,7	5,6	-	M5	17 ⁽¹⁾	5,5	15,5	-	-	-	-	5	3,5	-	-	7	-	3,5
16	34	30	8	M4	-	4,7	7,5	19	M5	32 ⁽²⁾	8	-	18	12	20	10	6	4,6	3,5	32	11	-	4,5
20	40	36	10	M5	-	5,8	9	22	M5	32 ⁽²⁾	8	-	20	15	25,5	12,7	8	5,7	5,7	38,5	12	-	4,5
25	44,5	40	10	M5	-	5,8	9	24,5	1/8"	38,5 ⁽³⁾	10,5	-	26	15,5	28	14	8	5,7	5,7	42	12	-	5,5
32	51	46	12	M6	24,5	5,8	9	27	1/8"	39,5 ⁽⁴⁾	11,5	36	32	-	34	-	10	5,7	-	48	15	5	11
40	58	55	12	M6	28	5,8	9	30,5	1/8"	39,5	11	42	42	-	40	-	10	5,7	-	55	15	6	12,5
50	70	65	16	M8	34	6,8	11	37,5	1/8"	39,5	11,5	50	50	-	50	-	13	6,8	-	65	17	6	13,5
63	89	80	16	M8	38,5	9	14	46	1/8"	42	11	62	62	-	60	-	13	8,8	-	80	17	8	15

(1) For BS type the dimension is 17, for BSM type the dimension is 27; (2) For strokes 20 and 25 mm, add +11 mm to dimension; (3) For strokes 20 and 25 mm, add +6 mm to dimension; (4) For strokes 20 and 25 mm, add +5 mm to dimension, while for stroke 30 mm add +10 mm to dimension.

Short Stroke Cylinders

Series BD - BDM



1 - CYLINDERS

Main features

12 ÷ 100

Bores Ø

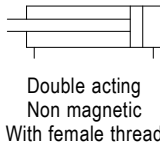

BD

Type



12 ÷ 100

Bores Ø

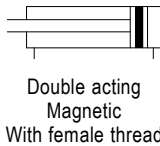

BDM

Type



Technical data

Bore Ø mm	12	16	20	25	32	40	50	63	80	100		
Fluid	Filtered compressed air with or without lubrication. Lubrication, if started, must be continued.											
Pressure range	2 ÷ 10 bar											
Temperature range	-20°C ÷ +80°C (standard)					-20°C ÷ +150°C (V)						
Port	M5					1/8"			1/4"			
Strokes*	BD	5 ÷ 40 mm		5 ÷ 50 mm			5 ÷ 100 mm		10 ÷ 100 mm			
	BDM	5 ÷ 40 mm		5 ÷ 100 mm		5 ÷ 125 mm		5 ÷ 160 mm		10 ÷ 200 mm		10 ÷ 250 mm
	..N	-			5 ÷ 125 mm				10 ÷ 125 mm		10 ÷ 160 mm	
Rod thread	M3	M4	M5	M6	M8	M10	M12					

*In case of intermediate strokes from the standard strokes (see table below), the cylinder body will have the overall dimensions of the cylinder with the next standard stroke, as desired stroke is obtained by applying a spacer.

Standard strokes

Stroke mm	BD Bore Ø mm										Stroke mm	BDM Bore Ø mm										Stroke mm	..N Bore Ø mm							
	12	16	20	25	32	40	50	63	80	100		12	16	20	25	32	40	50	63	80	100		20	25	32	40	50	63	80	100
5	✓	✓	✓	✓	✓	✓	✓				✓	✓	✓	✓	✓	✓														
10	✓	✓	✓	✓	✓	✓	✓	✓	✓		✓	✓	✓	✓	✓	✓	✓	✓	✓											
15	✓	✓	✓	✓	✓	✓	✓	✓	✓		✓	✓	✓	✓	✓	✓	✓	✓	✓											
20	✓	✓	✓	✓	✓	✓	✓	✓	✓		✓	✓	✓	✓	✓	✓	✓	✓	✓											
25	✓	✓	✓	✓	✓	✓	✓	✓	✓		✓	✓	✓	✓	✓	✓	✓	✓	✓											
30	✓	✓	✓	✓	✓	✓	✓	✓	✓		✓	✓	✓	✓	✓	✓	✓	✓	✓											
40	✓	✓	✓	✓	✓	✓	✓	✓	✓		✓	✓	✓	✓	✓	✓	✓	✓	✓											
50			✓	✓	✓	✓	✓	✓	✓				✓	✓	✓	✓	✓	✓	✓											
60																														
80																														
100																														
125																														
160																														
200																														
250																														

Key
 Standard stroke

Standard dimensions

1 - CYLINDERS

Type: **BD**
Ø 12

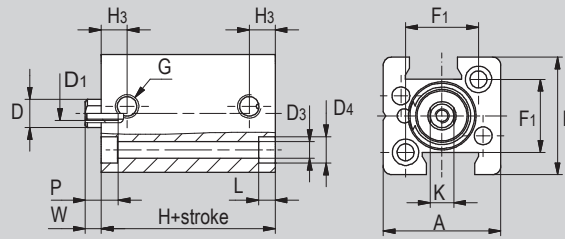

Type: **BD**
Ø 16 ÷ 25

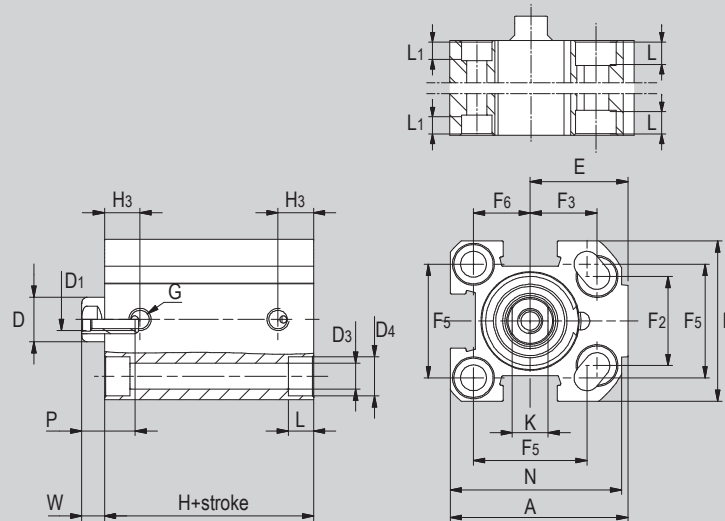

Type: **BD**
Ø 32 ÷ 100

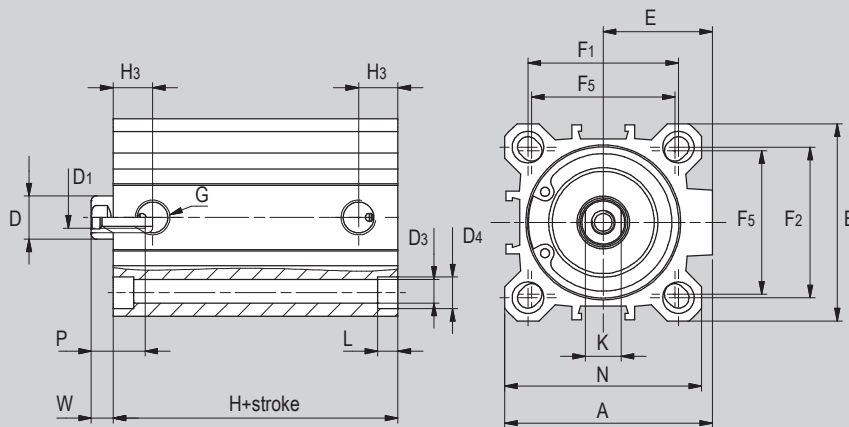

Ø (mm)	A	B	ØD	D ₁	ØD ₃	ØD ₄	E	G	H	H ₃	F ₁	F ₂	F ₃	F ₅	F ₆	K	L	L ₁	N	P	W
12	25	25	6	M3	3,7	5,6	-	M5	17	5,5	15,5	-	-	-	-	5	3,5	-	-	7	3,5
16	34	30	8	M4	4,7	7,5	19	M5	27 ⁽¹⁾	8	-	18	12	20	10	6	4,6	3,5	32	11	4,5
20	40	36	10	M5	5,8	9	22	M5	27 ⁽¹⁾	8	-	20	15	25,5	12,7	8	5,7	5,7	38,5	12	5
25	44,5	40	10	M5	5,8	9	24,5	1/8"	28,5 ⁽²⁾	10,5 ⁽³⁾	-	26	15,5	28	14	8	5,7	5,7	42	12	5,5
32	51	46	12	M6	5,8	9	27	1/8"	29,5	11,5 ⁽⁴⁾	36	32	-	34	-	10	5,7	-	48	15	6
40	58	55	12	M6	5,8	9	30,5	1/8"	29,5	11 ⁽⁴⁾	42	42	-	40	-	10	5,7	-	55	15	6
50	70	65	16	M8	6,8	11	37,5	1/8"	34,5	11,5	50	50	-	50	-	13	6,8	-	65	17	7,5
63	89	80	16	M8	9	14	46	1/8"	37	11	62	62	-	60	-	13	8,8	-	80	17	7
80	105	100	20	M10	9	14	55	1/4"	46	14	82	82	-	77	-	17	9	-	100	17	8
100	131	124	25	M12	11	17,2	69	1/4"	56	16	103	103	-	94	-	22	11	-	124	22	10

(1) For strokes 30, 40 and 50 mm, add +1 mm to dimension; (2) For strokes 40 and 50 mm, add +1 mm to dimension; (3) If quote H is less than 38,5 the dimension is 8,5; (4) If quote H is less than 39,5 the dimension is 8

Standard dimensions

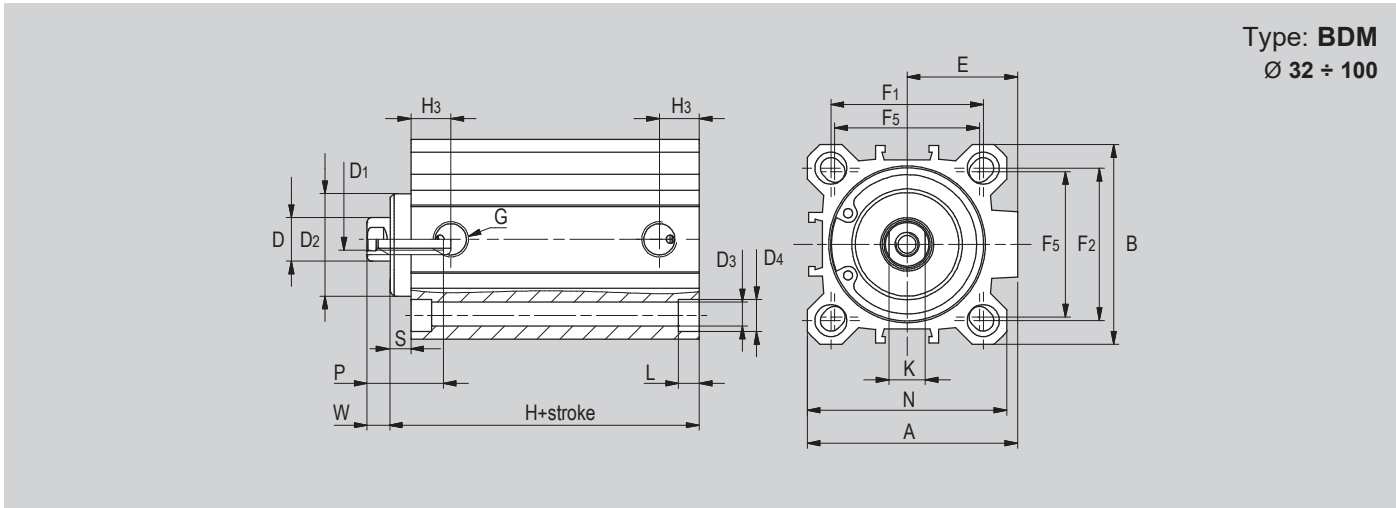
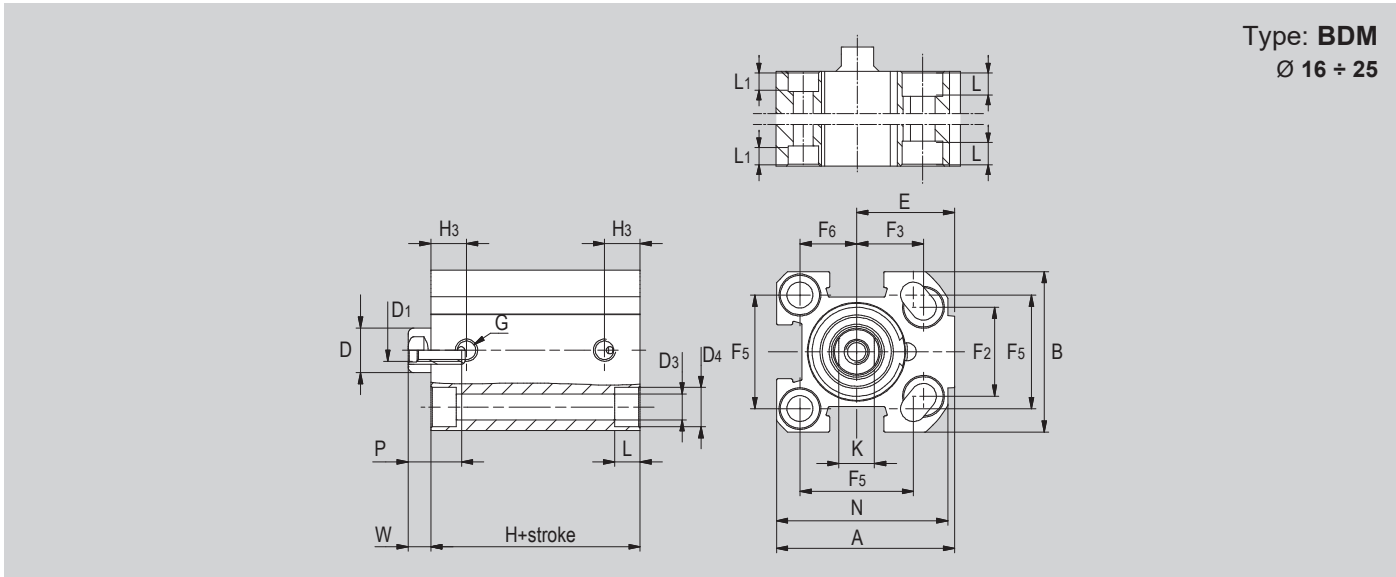
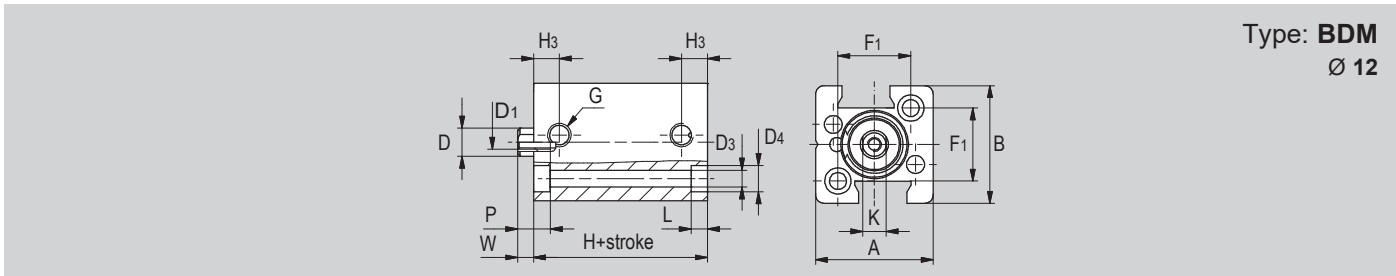

Ø (mm)	A	B	ØD	D ₁	ØD ₂	ØD ₃	ØD ₄	E	G	H	H ₃	F ₁	F ₂	F ₃	F ₅	F ₆	K	L	L ₁	N	P	S	W
12	25	25	6	M3	-	3,7	5,6	-	M5	27	5,5	15,5	-	-	-	-	5	3,5	-	-	7	-	3,5
16	34	30	8	M4	-	4,7	7,5	19	M5	32 ⁽¹⁾	8	-	18	12	20	10	6	4,6	3,5	32	11	-	4,5
20	40	36	10	M5	-	5,8	9	22	M5	32 ⁽¹⁾	8	-	20	15	25,5	12,7	8	5,7	5,7	38,5	12	-	5
25	44,5	40	10	M5	-	5,8	9	24,5	1/8"	38,5 ⁽²⁾	10,5	-	26	15,5	28	14	8	5,7	5,7	42	12	-	5,5
32	51	46	12	M6	24,5	5,8	9	27	1/8"	39,5	11,5	36	32	-	34	-	10	5,7	-	48	15	5	6
40	58	55	12	M6	28	5,8	9	30,5	1/8"	39,5	11 ⁽⁴⁾	42	42	-	40	-	10	5,7	-	55	15	6	6,5
50	70	65	16	M8	34	6,8	11	37,5	1/8"	39,5	11,5	50	50	-	50	-	13	6,8	-	65	17	6	7,5
63	89	80	16	M8	38,5	9	14	46	1/8"	42	11	62	62	-	60	-	13	8,8	-	80	17	8	7
80	105	100	20	M10	44	9	14	55	1/4"	46	14	82	82	-	77	-	17	9	-	100	17	10	8
100	131	124	25	M12	56	11	17,2	69	1/4"	56	16	103	103	-	94	-	22	11	-	124	22	10,5	10

(1) For strokes ≥ 25 mm, add +6 mm to dimension; (2) For strokes ≥ 25 mm, add +1 mm to dimension.

Dimensions with options

Type: ...N
Ø 20 ÷ 25

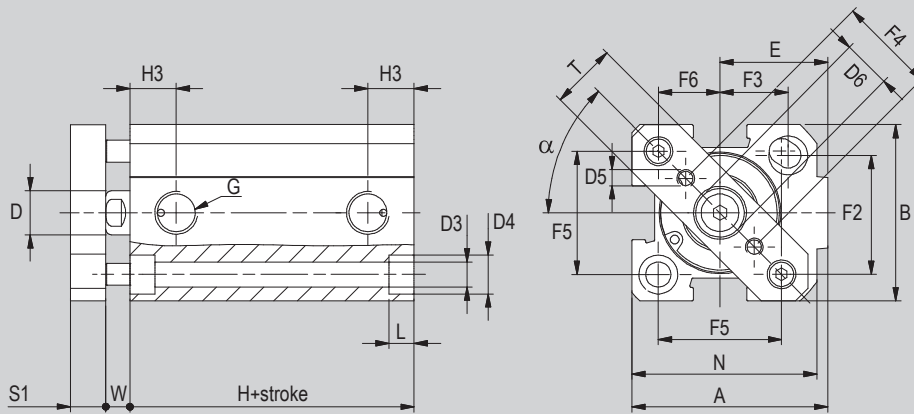

Type: ...N
Ø 32 ÷ 100

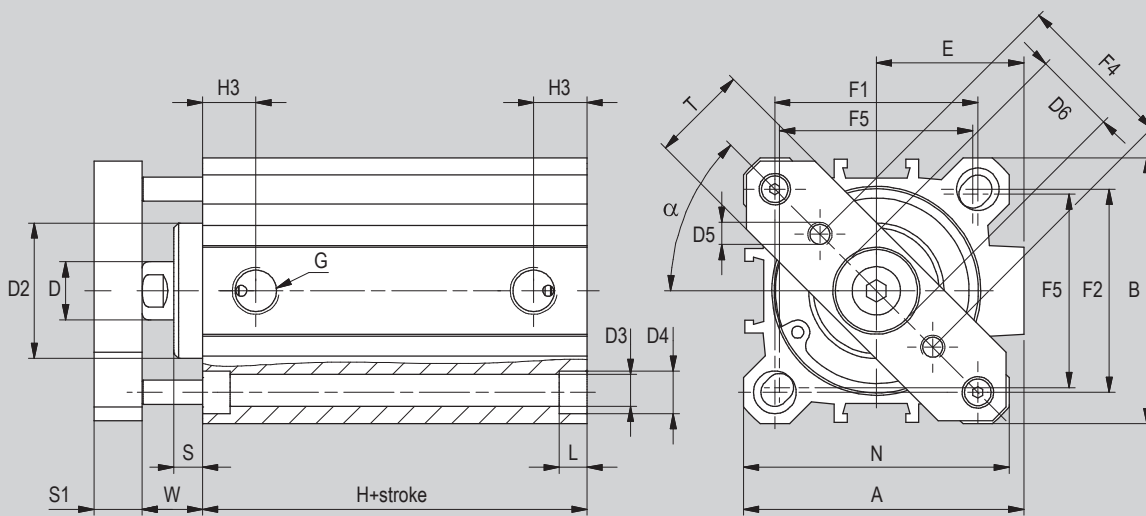

Ø (mm)	A	B	α	ØD	ØD ₂	ØD ₃	ØD ₄	D ₅	ØD ₆	E	G	H	H ₃	F ₁	F ₂	F ₃	F ₄	F ₅	F ₆	K	L	L ₁	N	S	S ₁	T	W
20	40	36	45°	10	-	5,8	9	M4	11	22	M5	32 ⁽¹⁾	8	-	20	15	20	25,5	12,7	8	5,7	5,7	38,5	-	8	15	4,5
25	44,5	40	45°	10	-	5,8	9	M4	11	24,5	1/8"	38,5 ⁽²⁾	10,5	-	26	15,5	22	28	14	8	5,7	5,7	42	-	8	15	5,5
32	51	46	41,5°	12	24,5	5,8	9	M5	17	27	1/8"	39,5	11,5	36	32	-	28	34	-	10	5,7	-	48	5	10	20	11
40	58	55	45°	12	28	5,8	9	M5	17	30,5	1/8"	39,5	11	42	42	-	33	40	-	10	5,7	-	55	6	10	20	12,5
50	70	65	45°	16	34	6,8	11	M6	22	37,5	1/8"	39,5	11,5	50	50	-	42	50	-	13	6,8	-	65	6	12	30	13,5
63	89	80	45°	16	38,5	9	14	M6	22	46	1/8"	42	11	62	62	-	50	60	-	13	8,8	-	80	8	12	30	15
80	105	100	45°	20	44	9	14	M8	28	56	1/4"	46	14	82	82	-	65	77	-	17	9	-	100	10	14	50	18
100	131	124	45°	25	56	11	17,2	M10	30	69	1/4"	56	16	103	103	-	80	94	-	22	11	-	124	10,5	14	50	20,5

(1) For strokes ≥ 25 mm, add +6 mm to dimension; (2) For strokes ≥ 25 mm, add +1 mm to dimension.

Dimensions with options

Type: ...P
Ø 16 ÷ 25

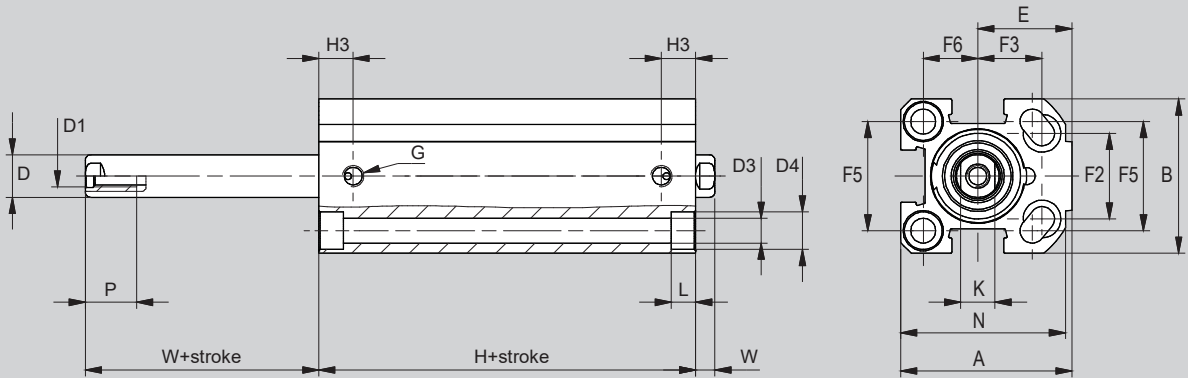

Type: ...P
Ø 32 ÷ 100

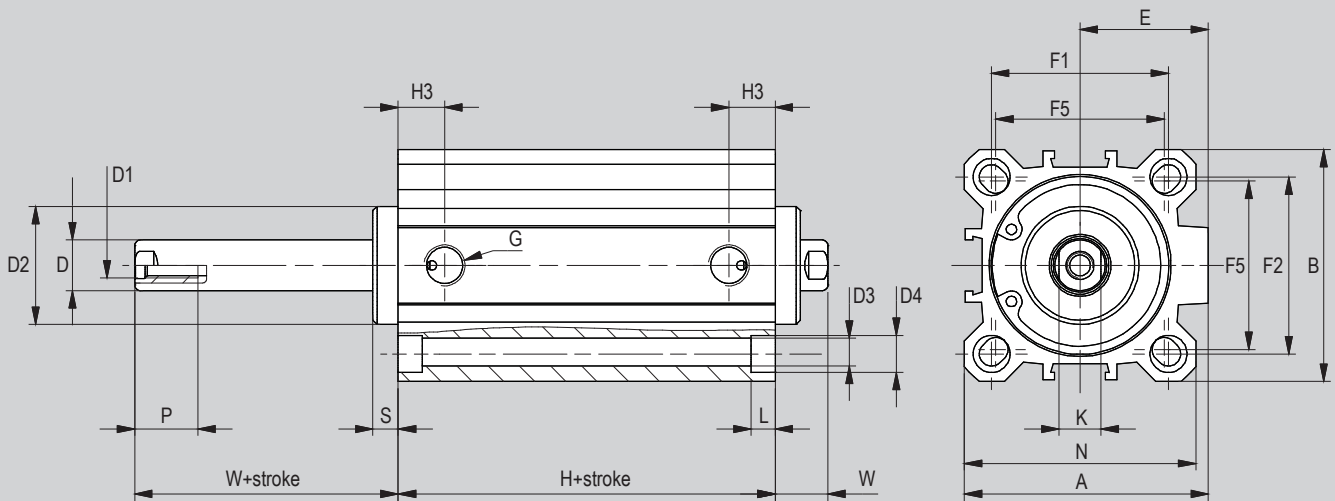

Ø (mm)	A	B	ØD	D ₁	ØD ₂	ØD ₃	ØD ₄	E	G	H	H ₃	F ₁	F ₂	F ₃	F ₅	F ₆	K	L	L ₁	N	P	S	W
16	34	30	8	M4	-	4,7	7,5	19	M5	32 ⁽¹⁾	8	-	18	12	20	10	6	4,6	3,5	32	11	-	4,5
20	40	36	10	M5	-	5,8	9	22	M5	32 ⁽¹⁾	8	-	20	15	25,5	12,7	8	5,7	5,7	38,5	12	-	4,5
25	44,5	40	10	M5	-	5,8	9	24,5	1/8"	38,5 ⁽²⁾	10,5	-	26	15,5	28	14	8	5,7	5,7	42	12	-	5,5
32	51	46	12	M6	24,5	5,8	9	27	1/8"	39,5	11,5	36	32	-	34	-	10	5,7	-	48	15	5	11
40	58	55	12	M6	28	5,8	9	30,5	1/8"	39,5	11	42	42	-	40	-	10	5,7	-	55	15	6	12,5
50	70	65	16	M8	34	6,8	11	37,5	1/8"	39,5	11,5	50	50	-	50	-	13	6,8	-	65	17	6	13,5
63	89	80	16	M8	38,5	9	14	46	1/8"	42	11	62	62	-	60	-	13	8,8	-	80	17	8	15
80	105	100	20	M10	44	9	14	55	1/4"	46	14	82	82	-	77	-	17	9	-	100	17	10	18
100	131	124	25	M12	56	11	17,2	69	1/4"	56	16	103	103	-	94	-	22	11	-	124	22	10,5	20,5

(1) For strokes ≥ 25 mm, add +6 mm to dimension; (2) For strokes ≥ 25 mm, add +1 mm to dimension.

Rod nipple N..AQB



For cylinder Ø mm	Code	Item	Filetto 1	Filetto 2
12	040079	N6-3AQB	M6x1	M3x0,5
16	040080	N6-4AQB	M6x1	M4x0,7
20-25	040081	N8-5AQB	M8x1,25	M5x0,8
32-40	040082	N10-6AQB	M10x1,25	M6x1
50-63	040083	N12-8AQB	M12x1,25	M8x1,25
50-63	040084	N16-8AQB	M16x1,5	M8x1,25
80	040085	N16-10AQB	M16x1,5	M10x1,5
100	040086	N20-12AQB	M20x1,5	M12x1,75

Female clevis* with clip FF..ISO



For cylinder Ø mm	Code	Item	Compliance
12-16	041002	FF06ISO/DIN	
20-25	041003	FF08ISO/DIN	
32-40	041004	FF10ISO	
50-63	041005	FF12ISO	
50-63-80	041006	FF16ISO	
100	041007	FF20ISO	

*Matching only with rod nipple N..AQB mounted

Female clevis* with pin and seeger FFP..ISO



For cylinder Ø mm	Code	Item	Compliance
12-16	-	FFP06ISO/DIN	
20-25	-	FFP08ISO/DIN	
32-40	041051	FFP10ISO	
50-63	041040	FFP12ISO	
50-63-80	041013	FFP16ISO	
100	041017	FFP20ISO	

*Matching only with rod nipple N..AQB mounted

Female clevis* (body only) FFN..ISO



For cylinder Ø mm	Code	Item	Compliance
12-16	041011	FFN06ISO/DIN	
20-25	041018	FFN08ISO/DIN	
32-40	041014	FFN10ISO	
50-63	041016	FFN12ISO	
50-63-80	041012	FFN16ISO	
100	041015	FFN20ISO	

*Matching only with rod nipple N..AQB mounted

Bearing head (DIN 648K) with female thread* RF..SE



For cylinder Ø mm	Code	Item	Compliance
12-16	041552	RF6SE	
20-25	041553	RF8SE	
32-40	041554	RF10SE	
50-63	041555	RF12SE	
50-63-80	041557	RF16SE	
100	041559	RF20SE	

*Matching only with rod nipple N..AQB mounted

Bearing head (DIN 648K) with male thread RM..SE



For cylinder Ø mm	Code	Item	Compliance
16	041500	RM4SE	
20-25	041501	RM5SE	
32-40	041502	RM6SE	
50-63	041503	RM8SE	
80	041550	RM10SE	
100	041514	RM12SE	

Axial articulated coupling* RBI..



For cylinder Ø mm	Code	Item	Compliance
12-16	041602	RBI6	-
20-25	041603	RBI8	
32-40	041604	RBI10	
50-63	041605	RBI12	
50-63-80	041607	RBI16	
100	041609	RBI20	

*Matching only with rod nipple N..AQB mounted

Angular articulated coupling* RBL..



For cylinder Ø mm	Code	Item	Compliance
12-16	041652	RBL6	-
20-25	041653	RBL8	
32-40	041654	RBL10	
50-63	041655	RBL12	
50-63-80	041657	RBL16	
100	041659	RBL20	

*Matching only with rod nipple N..AQB mounted

Self-aligning articulated coupling* GB..

	For cylinder Ø mm	Code	Item	Compliance
	12-16	041702	GB010	-
20-25	041703	GB020		
32-40	041704	GB040		
50-63	041706	GB060		
50-63-80	041708	GB100		
100	041709	GB120		

*Matching only with rod nipple N..AQB mounted

Self-aligning coupling* GC..

	For cylinder Ø mm	Code	Item	Compliance
	32-40	041722	GCM10x1,25	-
50-63	041723	GCM12x1,25		
50-63-80	041724	GCM16x1,5		
100	041725	GCM20x1,5		

*Matching only with rod nipple N..AQB mounted

Back head with integrated rear eye* in aluminium CM..ALB

	For cylinder Ø mm	Code	Item	Compliance
	16	040070	CM16ALB	-
20	040071	CM20ALB		
25	040072	CM25ALB		
32	040073	CM32ALB		
40	040074	CM40ALB		
50	040075	CM50ALB		
63	040076	CM63ALB		
80	040077	CM80ALB		
100	040078	CM100ALB		

Accessory to be ordered together with the cylinder

High foot in aluminium P..ALB

	For cylinder Ø mm	Code	Item	Compliance
	16	040087	P16ALB	-
20	040088	P20ALB		
25	040095	P25ALB		
32	040089	P32ALB		
40	040090	P40ALB		
50	040091	P50ALB		
63	040092	P63ALB		
80	040093	P80ALB		
100	040094	P100ALB		



Stainless Steel seeger for front head SGX..

	For cylinder Ø mm	Code	Item	Compliance
	25	171315	SGX025	-
32	171316	SGX032		
40	171317	SGX040		
50	171318	SGX050		
63	171319	SGX063		
80	171320	SGX080		
100	171321	SGX100		

Bracket AS108 (for magnetic reed switches T groove)

	For cylinder Ø mm	Code	Item	Cylinder matching
	12 ÷ 100	072915	AS108	BSM BDM

Magnetic reed switch T groove ASV..

	For cylinder Ø mm	Code	Item	Cylinder matching
	12 ÷ 100	070946 	ASV1C525	BSM* BDM*
071863		ASV1C550		
071864		ASV1C51K		
071189		ASV1C5M8		
073639		ASV4D225		
070246 		ASV4D2M8		
074900		ASV7N225		
070247		ASV7N2M8		
070372		ASV7M2M8		
072918		ASV1H525		

*With bracket AS.. for magnetic reed switches T groove

ATEX magnetic reed switch T groove MK..

	For cylinder Ø mm	Code	Item	Compliance	Cylinder matching
	12 ÷ 100	071120	MK500A	BSM* BDM*	
071108		MK502A			

*With bracket AS.. for magnetic reed switches T groove

COMPACT "L"

Cylinders



Find out our
key products



Solution for most applications



Easy and intuitive choice



Excellent value for money



Wide availability



Fast delivery



Features and certifications

Series of cylinders with reduced overall dimensions, available in bores from Ø 125 to 250, single acting or double acting, magnetic or non magnetic, with female thread. Made with round tube and tie-rods. Supplied as standard in compliance with Reach and RoHS directives, and SIL certified. On request, can be also supplied according to the 2014/34/EU ATEX Directive.



Type CLS Ø 125 ÷ 200 from page 1.21.20



Reduced overall dimension cylinders, available in bores from Ø 125 to 200, single acting, non magnetic, with female thread, made with round tube and tie-rods.

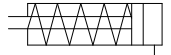

Type CLSM Ø 125 ÷ 200 from page 1.21.20



Reduced overall dimension cylinders, available in bores from Ø 125 to 200, single acting, magnetic, with female thread, made with round tube and tie-rods. Suitable for mounting magnetic reed switches on tie rods (with bracket to be ordered separately).

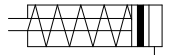

Type CLD Ø 125 ÷ 250 from page 1.21.40



Reduced overall dimension cylinders, available in bores from Ø 125 to 250, double acting, non magnetic, with female thread, made with round tube and tie-rods.

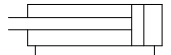

Type CLDM Ø 125 ÷ 250 from page 1.21.40



Reduced overall dimension cylinders, available in bores from Ø 125 to 250, double acting, magnetic, with female thread, made with round tube and tie-rods. Suitable for mounting magnetic reed switches on tie rods (with bracket to be ordered separately).

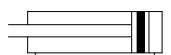

Options

Description	Symbol	Suffix
Male threaded rod		M1
Anti-rotating plate (available only for type CLD and CLDM up to Ø 200)		N
Through rod (available only for type CLD and CLDM)		P
FKM seals -20°C ÷ +150°C		V
ATEX versions on request		/ATEX
Special versions on request		/S

The options, when possible, can be combined with each other. For options matching see from page 1.21.4; For code key see from page 1.21.5

Standard materials

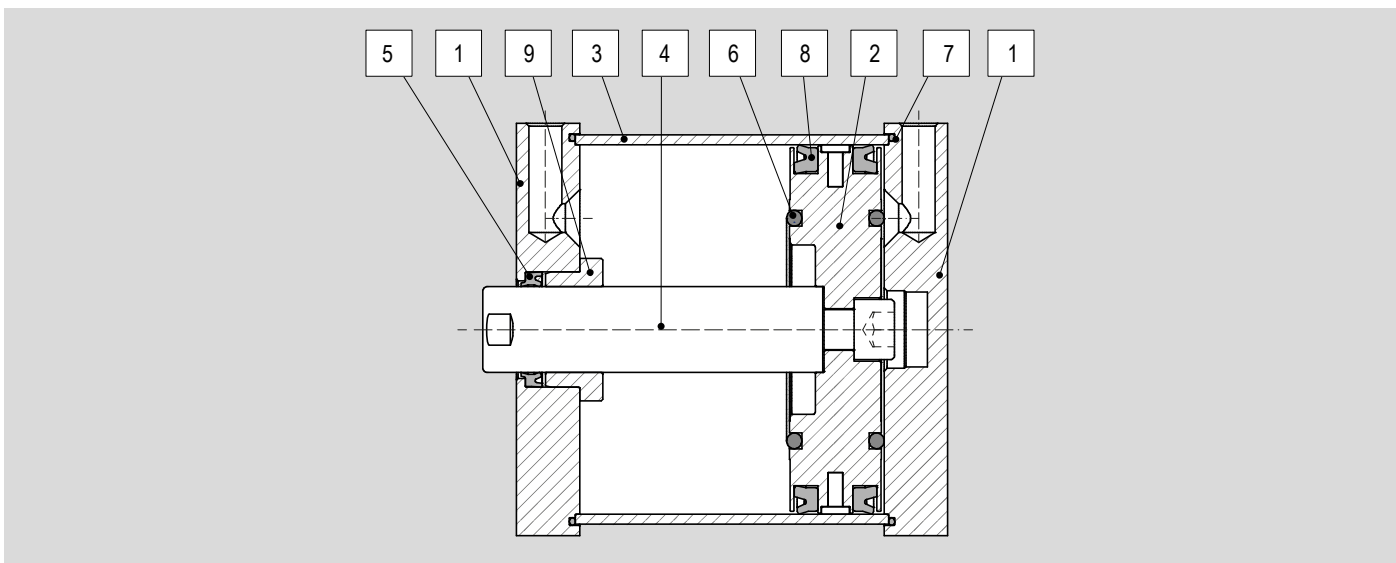

Position	Description	Materials			
		Ø 125	Ø 160	Ø 200	Ø 250
1	End cover	Aluminium			
2	Piston	Aluminium			
3	Tube	Anodised aluminium			
4	Rod	Stainless Steel AISI 303			
5	Rod seal	Polyurethane (PU)			
6	Elastic damper	NBR			
7	Barrel o-ring	NBR			
8	Piston seal	Polyurethane (PU)			
9	Bush	Brass			
-	Tie-rods	Steel			

Options matching

Series	Bore	Model	Standard options matching				
			M1	N (Ø125÷200)	P	V	/ATEX
CLS-CLSM	Ø 125 ÷ 200	Standard	●	-	-	●	●
	Ø 125 ÷ 200	Male threaded rod (M1)		-	-	●	●
CLD	Ø 125 ÷ 250	Standard	●	●	●	●	●
	Ø 125 ÷ 250	Through rod (P)	● ⁽¹⁾	-		●	●
	Ø 125 ÷ 250	Male threaded rod (M1)		● ⁽¹⁾	● ⁽¹⁾	●	●
CLDM	Ø 125 ÷ 250	Standard	●	●	●	●	●
	Ø 125 ÷ 250	Anti-rotating plate (N)	● ⁽¹⁾		●	●	●
	Ø 125 ÷ 250	Through rod (P)	● ⁽¹⁾	-		●	●
	Ø 125 ÷ 250	Male threaded rod (M1)		● ⁽¹⁾	● ⁽¹⁾	●	●

Key

● allowed matching; - not allowed matching

Option combinations - notes

(1) The male threaded rod (option **M1**) in combination with through rod (option **P**) is applied on both sides of rod, except when combined with the anti-rotation plate (option **N**), in which case the male rod will only be applied on the side opposite the plate.

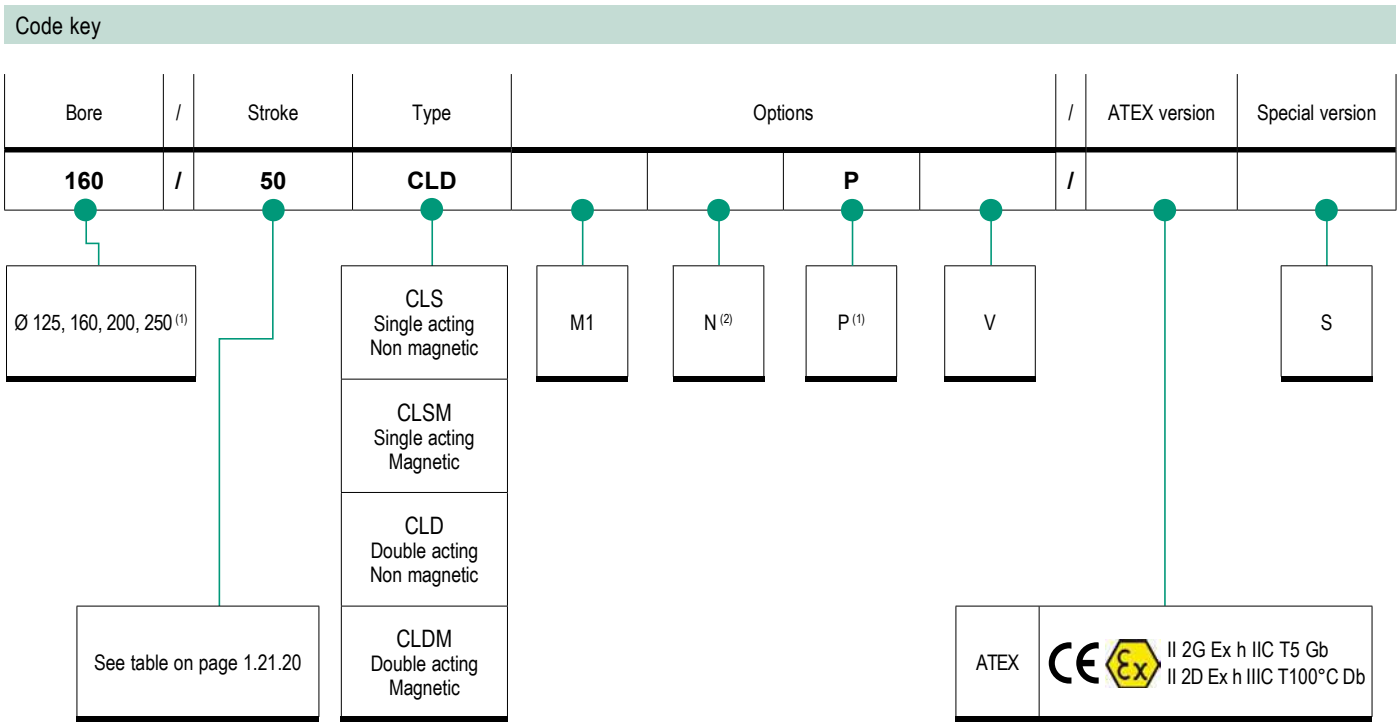

How to order

Bore	/	Stroke	Type	Options
160	/	50	CLD	P

Notes

Options in the same grid are alternative to each others.
 For further information on options and their matching, see page 1.21.3 and 1.21.4
 For standard materials see page 1.21.3
 (1) Available only for types CLD and CLDM
 (2) Available only for types CLD and CLDM, up to Ø 200
 For further information on the ATEX 2014/34/EU Directive, on classifications and protections, see from page III.1

Seal kit standard*

Number of components	Description
n. 1	Rod seal
n. 2	Barrell o-ring
n. 2	Piston seal
n. 2	Elastic dampers

*For cylinders with option P or V, the kit include further components.

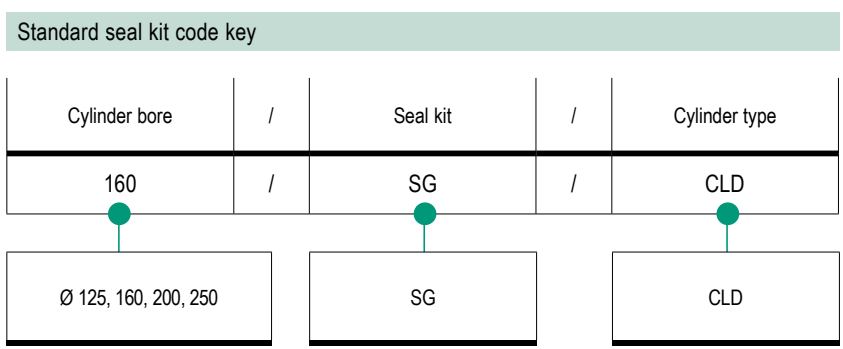

Accessories

1 - CYLINDERS

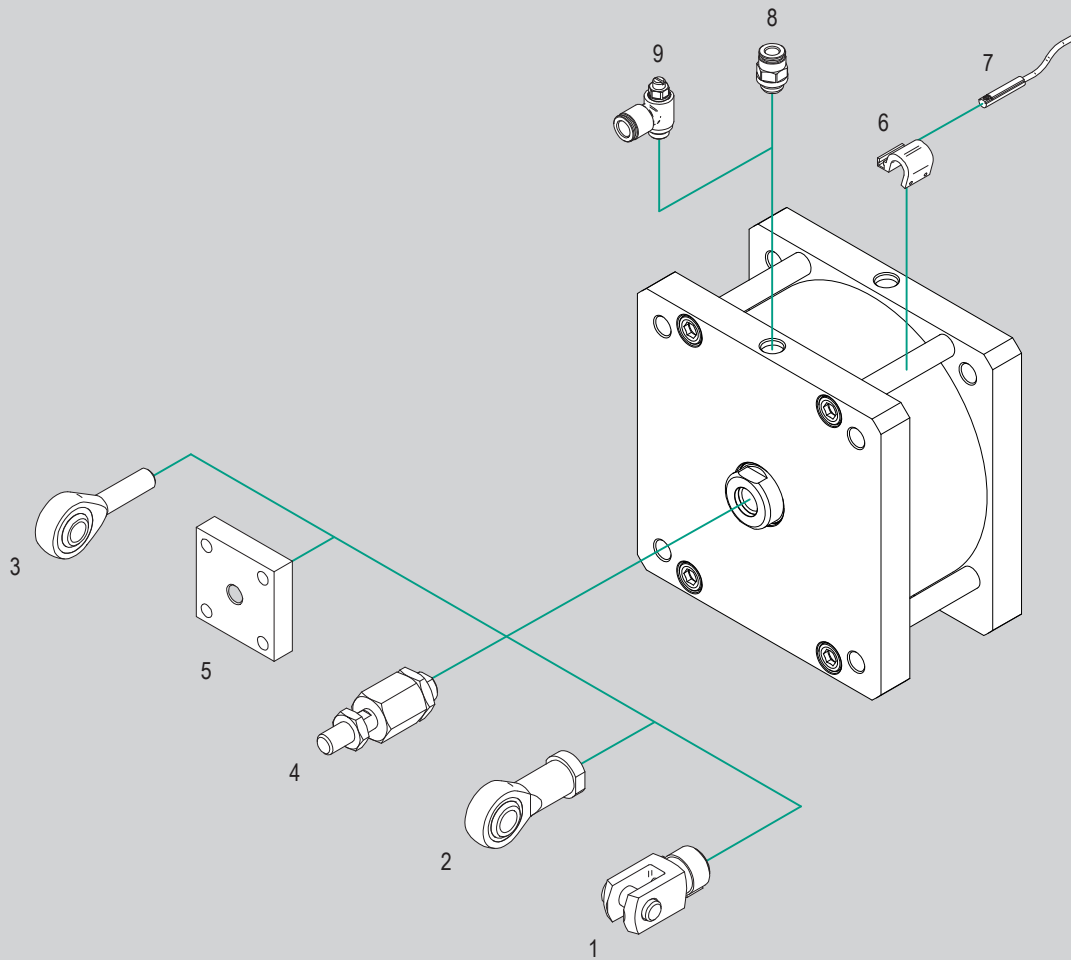

N.	Cylinder bore	Item	Description	Compliance	Matching		Code page	Data sheet page
					CLS-CLD	CLSM-CLDM		
1	Ø 125 ÷ 250	FFP..ISO	ISO female clevis with pin and seeger		● ⁽¹⁾	● ⁽¹⁾	1.21.90	1.85.11
		FFN..ISO	ISO female clevis (body only)		● ⁽¹⁾	● ⁽¹⁾		
2	Ø 125 ÷ 250	RF..SE	Bearing head (DIN 648K) with female thread	ISO 8139	● ⁽¹⁾	● ⁽¹⁾		1.90.1
3	Ø 125	RM..SE	Bearing head (DIN 648K) with male thread		●	●		1.90.2
4	Ø 125 ÷ 250	GB..	Bearing - Self-aligning articulated coupling		● ⁽¹⁾	● ⁽¹⁾		1.90.10
5	Ø 125 ÷ 250	GC..	Self-aligning coupling		● ⁽¹⁾	● ⁽¹⁾		1.90.40
6	Ø 125 ÷ 250	AS..	Bracket for reed switches type "T"	-	-	●		1.120.3
7	Ø 125 ÷ 250	ASV..	Magnetic reed switch T groove	2014/34/UE	-	●		1.110.10
		MK..	ATEX magnetic reed switch T groove		-	●		1.113.1
8	Ø 125 ÷ 250	R..	Push-in fittings	-	●	●		4.2.1
9	Ø 125 ÷ 250	V..C	Flow controls, for cylinders	-	●	●		4.94.1

Key

● matching accessory; - not matching accessory

(1) Matching only with option M1

Compact "L" Cylinders

Series CLS - CLSM



Main features

125 ÷ 200

Bores Ø

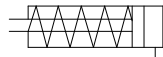

Single acting
Non magnetic
With female thread

CLS

Type



125 ÷ 200

Bores Ø

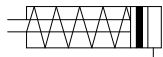

Single acting
Magnetic
With female thread

CLSM

Type



Technical data

Bore Ø mm	125	160	200
Fluid	Filtered compressed air with or without lubrication. Lubrication, if started, must be continued.		
Pressure range	2 ÷ 10 bar		
Temperature range	-20°C ÷ +80°C (standard)		-20°C ÷ +150°C (V)
Port	1/4"	3/8"	
Strokes	CLS	10 ÷ 50 mm	
	CLSM	10 ÷ 50 mm	
Rod thread	M14	M20	

Standard strokes

Stroke mm	CLS Bore Ø mm		
	125	160	200
10			
25			
50			

Stroke mm	CLSM Bore Ø mm		
	125	160	200
10			
25			
50			

Key
 Standard stroke

Standard dimensions

Type: CLS, CLSM

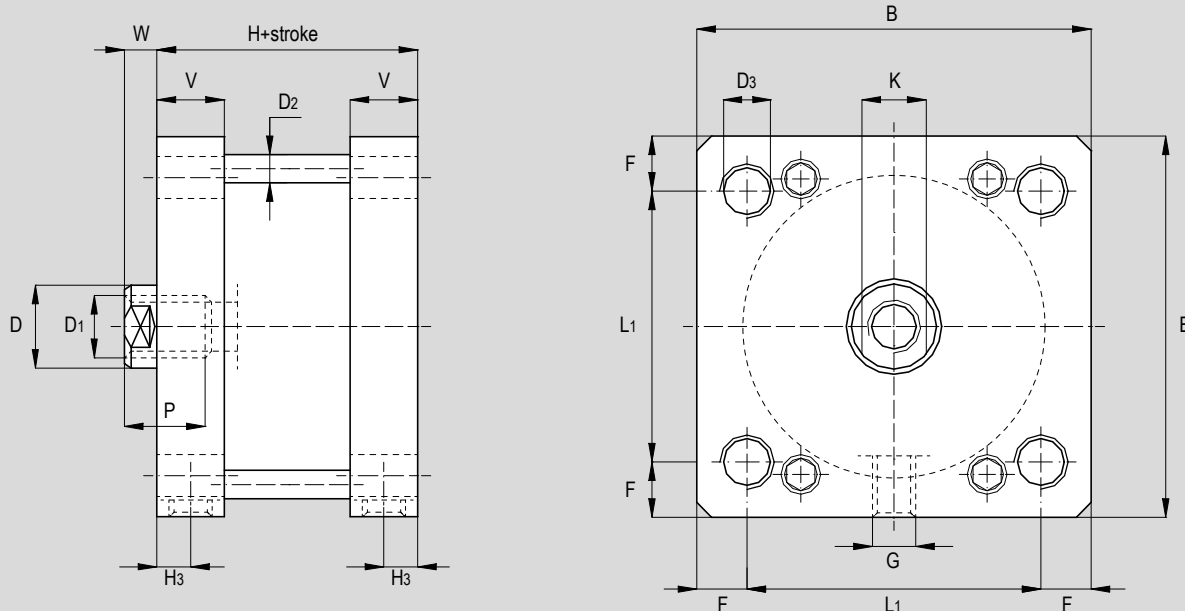

Ø (mm)	B	ØD	ØD ₁	ØD ₂	ØD ₃	F	G	H ₃	L ₁	K	P	V	W	H
125	140	30	M14	10	M12	15	1/4"	10	110	28	25	22	10	78
160	180	40	M20	12	M16	20	3/8"	12	140	36	30	26	12	87
200	220	40	M20	14	M16	22,5	3/8"	12	175	36	30	26	12	87

Dimensions with options

Type: ..M1

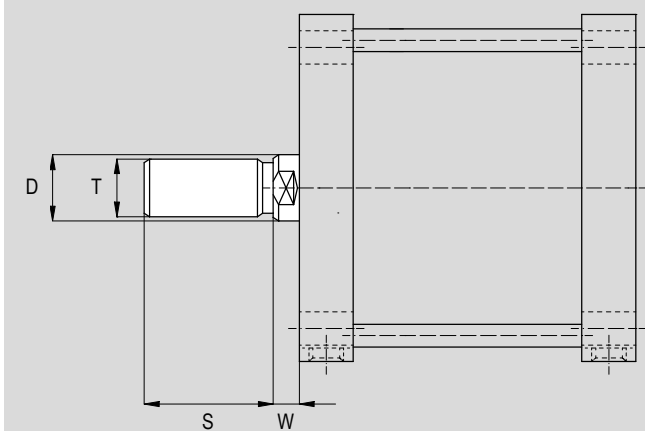

Type: ..V

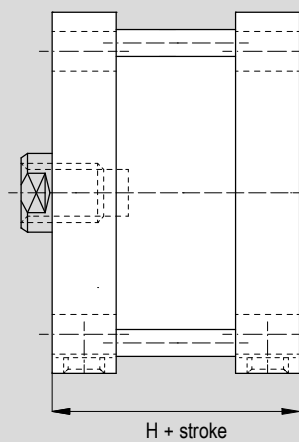

\varnothing (mm)	T	$\varnothing D$	W	S	H
125	M27x2	30	10	54	83
160	M36x2	40	12	72	91
200	M36x2	40	12	72	105

Compact "L" Cylinders

Series CLD - CLDM



1 - CYLINDERS

Main features

125 ÷ 250

Bores Ø

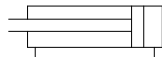

Double acting
Non magnetic
With female thread

CLD

Type



125 ÷ 250

Bores Ø

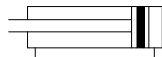

Double acting
Magnetic
With female thread

CLDM

Type



Technical data

Bore Ø mm	125	160	200	250
Fluid	Filtered compressed air with or without lubrication. Lubrication, if started, must be continued.			
Pressure range	2 ÷ 10 bar			
Temperature range	-20°C ÷ +80°C (standard)		-20°C ÷ +150°C (V)	
Port	1/4"	3/8"	1/2"	
Strokes	CLD	25 ÷ 300 mm		
	CLDM	25 ÷ 300 mm		
Rod thread	M14	M20	M24	

Standard strokes

Stroke mm	CLD Bore Ø mm			
	125	160	200	250
25				
50				
75				
100				
125				
160				
200				
250				
300				

Stroke mm	CLDM Bore Ø mm			
	125	160	200	250
25				
50				
75				
100				
125				
160				
200				
250				
300				

Key
 Standard stroke

Standard dimensions

Type: **CLD, CLDM**

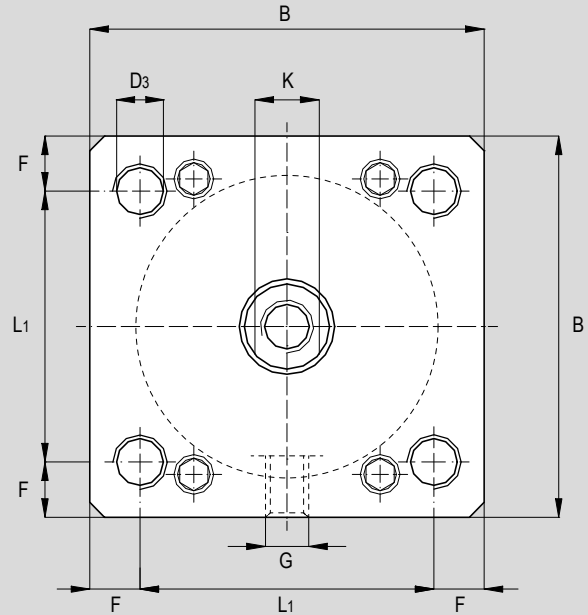
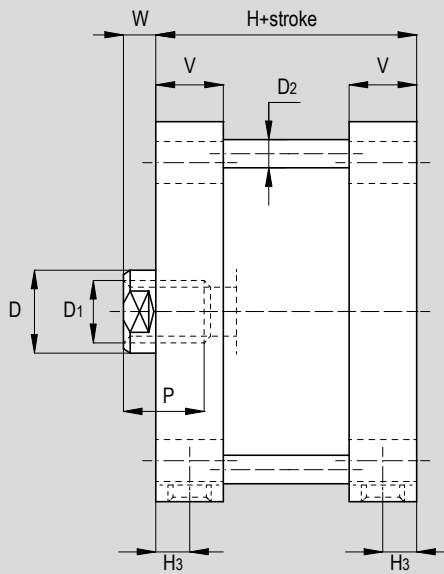

∅ (mm)	B	∅D	∅D ₁	∅D ₂	∅D ₃	F	G	H ₃	L ₁	K	P	V	W	H
125	140	30	M14	10	M12	15	1/4"	10	110	28	25	22	10	78
160	180	40	M20	12	M16	20	3/8"	12	140	36	30	26	12	87
200	220	40	M20	14	M16	22,5	3/8"	12	175	36	30	26	12	87
250	270	40	M24	16	M20	25	1/2"	15	220	36	35	-	12	116

Dimensions with options

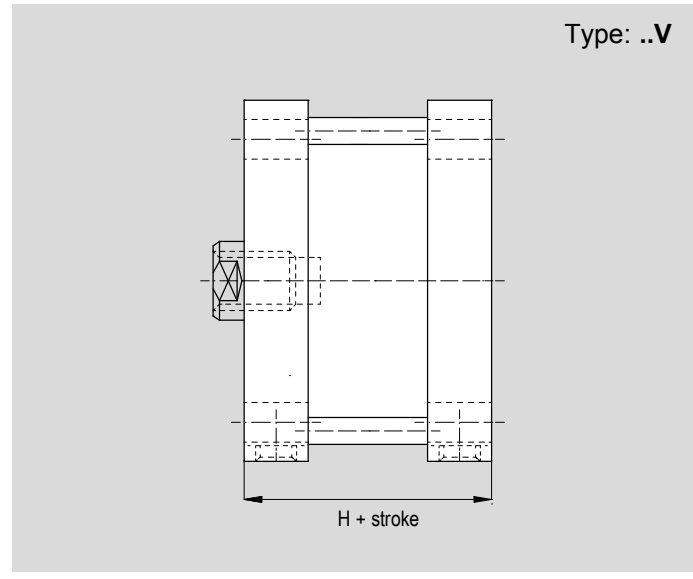
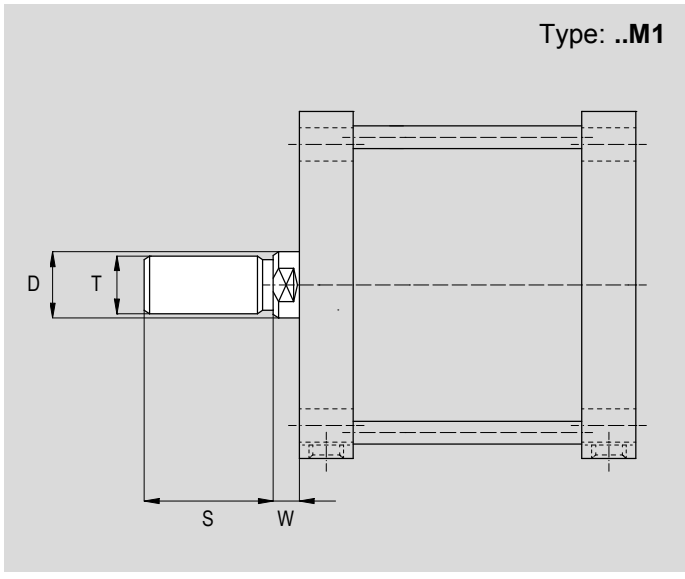

\varnothing (mm)	T	$\varnothing D$	W	S	H
125	M27x2	30	10	54	83
160	M36x2	40	12	72	91
200	M36x2	40	12	72	105
250	M36x2	40	12	72	116

Dimensions with options

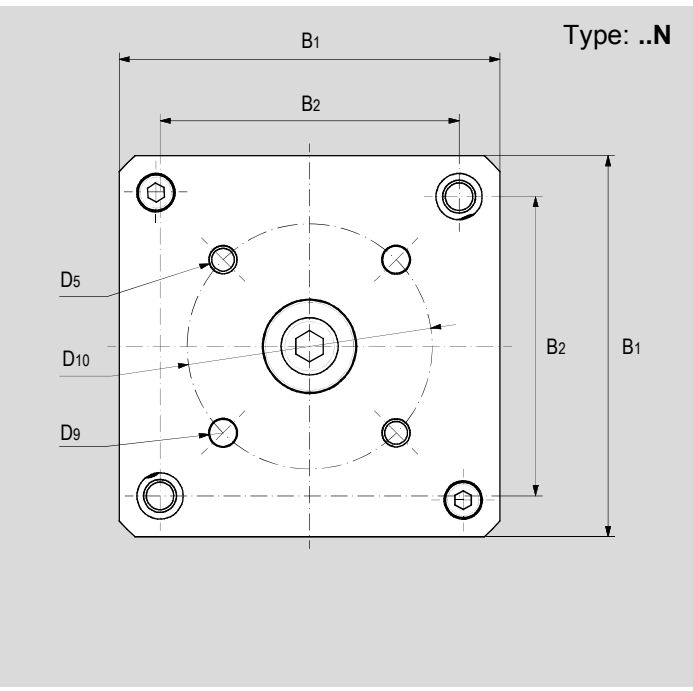
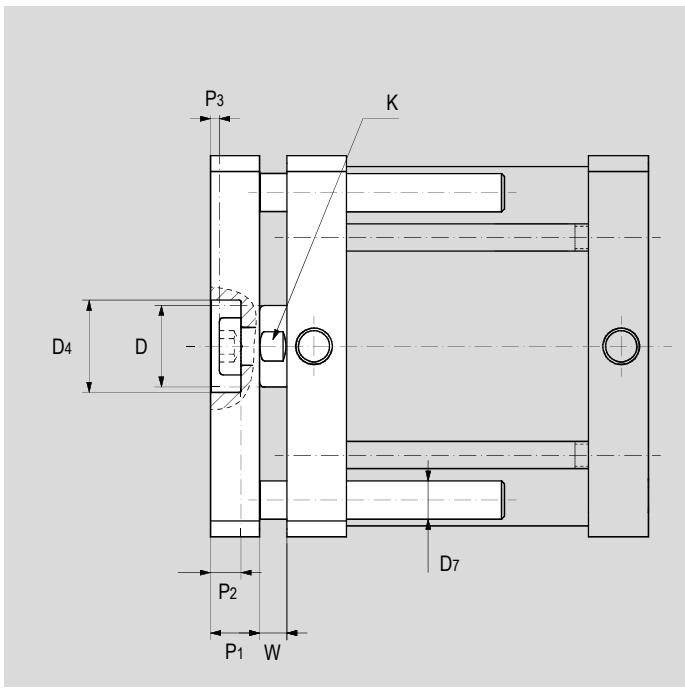

\varnothing (mm)	B_1	B_2	$\varnothing D$	$\varnothing D_4$	$\varnothing D_5$	$\varnothing D_7$	$\varnothing D_9$	$\varnothing D_{10}$	P_1	P_2	P_3	K	W
125	140	110	30	34	M10	14	10	90	18	12	3	28	10
160	180	140	40	46	M12	20	12	110	23	16	3	36	12
200	220	175	40	46	M12	20	12	110	23	16	3	36	12

Dimensions with options

Type: ..P

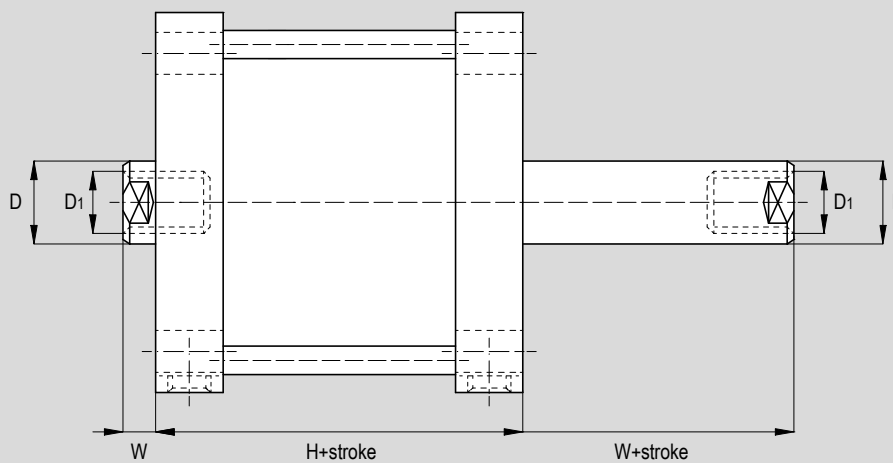

\varnothing (mm)	$\varnothing D$	$\varnothing D_1$	W	H
125	30	M14	10	78
160	40	M20	12	87
200	40	M20	12	87
250	40	M24	12	116

Female clevis* with pin and seeger FFP..ISO

	For cylinder Ø mm	Code	Item	Compliance
	125	041009	FFP27ISO	
	160÷250	041010	FFP36ISO	

*Matching only with option M1

Female clevis* (body only) FFN..ISO

	For cylinder Ø mm	Code	Item	Compliance
	125	**	FFN27ISO	
	160÷250	**	FFN36ISO	

*Matching only with option M1

**For codes, please contact the sales department

Bearing head (DIN 648K) with female thread* RF..SE

	For cylinder Ø mm	Code	Item	Compliance
	125	041562	RF27SE	
	160÷250	041563	RF35SE	

*Matching only with option M1

Bearing head (DIN 648K) with male thread RM..SE

	For cylinder Ø mm	Code	Item	Compliance
	125	041506	RM14SE	
	160÷250	041506	RM14SE	

Giunti autoallineanti assiali* GB..

	For cylinder Ø mm	Code	Item	Compliance
	125	041711	GB130	-
	160÷250	041712	GB160-200	



*Matching only with option M1

Giunti autoallineanti* GC..

	For cylinder Ø mm	Code	Item	Compliance
	125	041726	GCM27x2	-
	160÷250	041727	GCM36x2	

*Matching only with option M1

Magnetic reed switch T groove ASV..

	For cylinder Ø mm	Code	Item	Cylinder matching
	125 ÷ 250	070946 	ASV1C525	CLSM* CLDM*
		071863	ASV1C550	
		071864	ASV1C51K	
		071189	ASV1C5M8	
		073639	ASV4D225	
		070246 	ASV4D2M8	
		070247	ASV7N2M8	
		070372	ASV7M2M8	
		072918	ASV1H525	

*With bracket type AS.. for magnetic reed switches T groove

ATEX magnetic reed switch T groove MK..

	For cylinder Ø mm	Code	Item	Compliance	Cylinder matching
	125 ÷ 250	071120	MK500A		CLSM* CLDM*
		071108	MK502A		

*With bracket type AS.. for magnetic reed switches T groove

Bracket AS.. for magnetic reed switches T groove

	For cylinder Ø mm	Code	Item	Cylinder matching
	125	072908	AS101	CLSM* CLDM*
	160	072909	AS102	
	200	072910	AS103	
	250	072911	AS104	

COMPACT

Guided cylinders



Find out our
key products



Solution for most applications



Easy and intuitive choice



Excellent value for money



Wide availability



Fast delivery



Features and certifications

Series of compact guided cylinders, available in bores from $\varnothing 6$ to 100, double acting, magnetic, with self-lubricating bushings or spherical bearings. Supplied as standard in compliance with Reach and RoHS directives. On request, type GEDB and GEDS can be also supplied according to the 2014/34/EU ATEX Directive.



Type GEDB $\varnothing 6 \div 100$

from page 1.23.20



Compact guided cylinders, available in bores from $\varnothing 6$ to 100, double acting, magnetic, with self-lubricating bushings. The extruded body is machined with grooves allowing the mounting of magnetic reed switches directly, not protruding beyond the profile of the cylinder, and elastic dampers on front and end covers. On request these cylinders can be supplied according to the ATEX Directive.

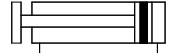

Type GEDS $\varnothing 12 \div 100$

from page 1.23.20



Compact guided cylinders, available in bores from $\varnothing 12$ to 100, double acting, magnetic, with spherical bearings. The extruded body is machined with grooves allowing the mounting of magnetic reed switches directly, not protruding beyond the profile of the cylinder, and elastic dampers on front and end covers. On request these cylinders can be supplied according to the ATEX Directive.

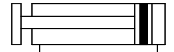

Type GPB $\varnothing 12 \div 63$

from page 1.23.50



Compact guided cylinders, available in bores from $\varnothing 12$ to 63, double acting, magnetic, with self-lubricating bushings. Made of solid aluminium machined allow high torsion and lateral loads. Equipped with grooves for mounting magnetic reed switches directly, not protruding beyond the profile of the cylinder, and elastic dampers on front and end covers.

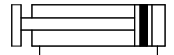

Type GPS $\varnothing 12 \div 63$

from page 1.23.50



Compact guided cylinders, available in bores from $\varnothing 12$ to 63, double acting, magnetic, with spherical bearings. Made of solid aluminium machined allow high torsion and lateral loads. Equipped with grooves for mounting magnetic reed switches directly, not protruding beyond the profile of the cylinder, and elastic dampers on front and end covers.

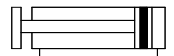

Options		
Description	Symbol	Suffix
FKM seals (only for series GED.. from Ø 10 to 100) -20°C ÷ +150°C		V
ATEX versions on request (only for series GED..)		/ATEX
Special versions on request		/S

The options, when this is possible, can be combined with each other. For options matching and code key, see the tables below.

Options matching				
Series	Bore	Model	Standard options matching	
			V (Ø10÷100)	/ATEX
GEDB	Ø 6 ÷ 100	Standard	●	●
GEDS	Ø 12 ÷ 100	Standard	●	●
GPB-GPS	Ø 12 ÷ 63	Standard	-	-

Key

● allowed matching; - not allowed matching

Code key

Bore	/	Stroke	Type	Options ⁽¹⁾	/	ATEX version ⁽¹⁾	Special version
32	/	50	GEDB	V	/		

Ø 6*, 10*, 12, 16, 20, 25, 32, 40, 50, 63, 80**, 100**

For strokes see table on page 1.23.20 (GEDB-GEDS) 1.23.50 (GPB-GPS)

GEDB
Single acting
Magnetic
With self-lubricating bushings

 GEDS
Double acting
Magnetic
With spherical bearings

 GPB
Double acting
Magnetic
With self-lubricating bushings

 GPS
Double acting
Magnetic
With spherical bearings

V

ATEX II 2G Ex h IIC T5 Gb II 2D Ex h IIIC T100°C Db

S

*Only GEDB type
**Only GEDB - GEDS type

How to order

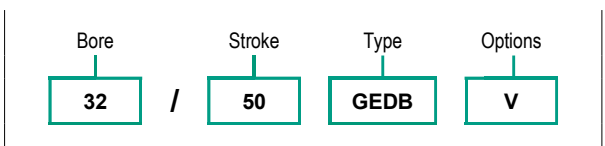

Notes

For further information on options and their matching, see tables above.
 For further information on the ATEX 2014/34/EU Directive, on classifications and protections, see from page III.1
 (1) Only for GEDB and GEDS type.

Standard materials

Type: **GEDB, GEDS**

1 - CYLINDERS

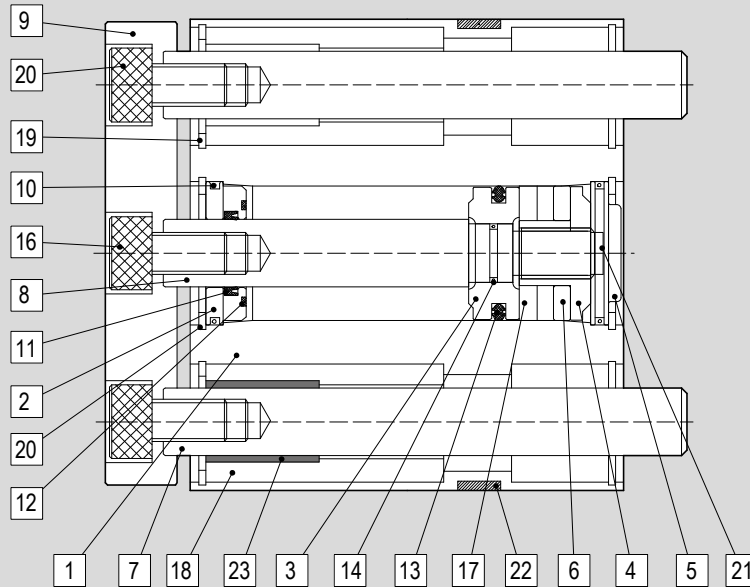

Position	Description	Materials		
		GEDB		GEDS
		Ø 6 ÷ 10	Ø 12 ÷ 100	Ø 12 ÷ 100
1	Body	Anodised aluminium		Anodised aluminium
2	Head cover	Iron	Anodised aluminium	Anodised aluminium
3	Piston	Copper		
4	Ring	Copper		
5	End cover	Anodised aluminium		
6	Ring	PTFE		
7	Rod	Carbon steel		
8	Rod	Carbon steel		
9	Plate	Anodised aluminium		
10	Head cover o-ring	NBR		
11	Rod seal	NBR		
12	Cushioning o-ring	NBR		
13	Piston seal	NBR		
14	Piston o-ring	NBR		
15	Snap ring	Armonic steel		
16	Mounting rod nut	Steel		
17	Magnet	Polymer		
18	Bush support	Copper		
19	Snap ring holder	Steel		
20	Plate screw	Steel		
21	Rubber lining	NBR		
22	Magnet	Polymer		
23	Bush	PTFE		
24	Linear bearing	-		Steel
25	Rod	Steel		

Standard materials

Type: **GPB, GPS**

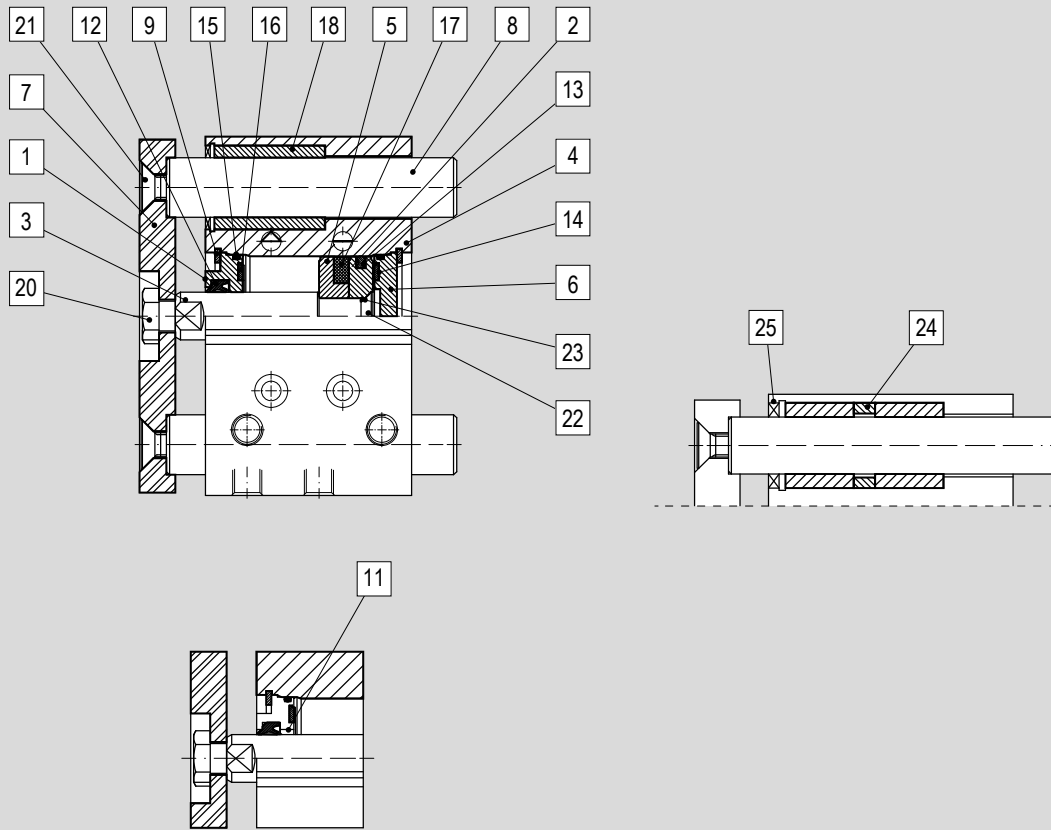

1 - CYLINDERS

Position	Description	Materials							
		Ø 12	Ø 16	Ø 20	Ø 25	Ø 32	Ø 40	Ø 50	Ø 63
1	Head cover	Brass		Hard anodised aluminium					
2	Piston	Hard anodised aluminium							
3	Rod	Stainless Steel		Carbon steel					
4	Body	Hard anodised aluminium							
5	Magnet holder	Hard anodised aluminium							
6	End cover	Hard anodised aluminium							
7	Guide plate	Nickel-plated carbon steel							
8	Rod guide	GPB	Carbon steel						
		GPS	Special steel						
9	Retaining ring	Nickel-plated carbon steel							
10	Retaining ring	Nickel-plated carbon steel							
11	Oilless bearing	Oil-impregnated sintered alloy							
12	Rod packing	NBR							
13	Piston seal	NBR							
14	Rubber lining	NBR							
15	Cylinder gasket	NBR							
16	Rubber lining	NBR							
17	Magnet	Magnetic material							
18	Oilless bearing	Oil-impregnated sintered alloy							
19	Linear bearing	Special steel							
20	Hexagon socket head screw	Nickel-plated carbon steel							
21	Screw	Nickel-plated carbon steel							
22	Screw	Nickel-plated carbon steel							
23	O-ring	NBR							
24	Stroke pad	Hard anodised aluminium							
25	Dust cover	Aluminium			Carbon steel - NBR				

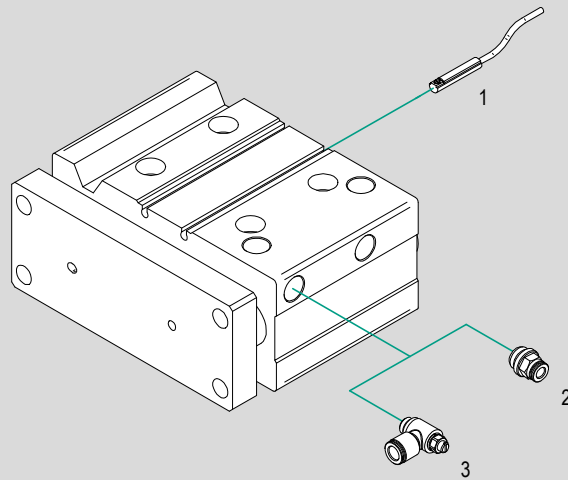

N.	Cylinder bore	Item	Description	Compliance	Matching		Code page	Data sheet page
					GEDB - GEDS	GPB - GPS		
1	Ø 6 ÷ 100	ASC..	Magnetic reed switch C groove	-	●	●	1.23.90	1.110.30
2	Ø 6 ÷ 100	R..	Push-in fittings		●	●	4.2.1	
3	Ø 6 ÷ 100	V..C	Flow controls, for cylinders		●	●	4.94.1	

Key

● matching accessory; - not matching accessory

Main features

6 ÷ 100

Bores Ø

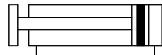

Double acting
Magnetic
With self-lubricating
bushings

GEDB

Type



12 ÷ 100

Bores Ø

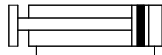

Double acting
Magnetic
With spherical
bearings

GEDS

Type



Technical data

Bore Ø mm	6	10	12	16	20	25	32	40	50	63	80	100	
Fluid	Filtered compressed air with or without lubrication. Lubrication, if started, must be continued.												
Pressure range	1,5 ÷ 7 bar							1 ÷ 7 bar					
Maximum pressure	9 bar												
Temperature range	0°C ÷ +60°C (standard)						-20°C ÷ +150°C (V)						
Speed	50 ÷ 500 mm/s								50 ÷ 350 mm/s				
Port	M3			M5				1/8"		1/4"		3/8"	
Strokes*	GEDB	5 ÷ 15 mm	5 ÷ 20 mm	10 ÷ 100 mm	25 ÷ 200 mm			30 ÷ 250 mm		30 ÷ 150 mm			
	GEDS	-		10 ÷ 100 mm	25 ÷ 200 mm			30 ÷ 250 mm		30 ÷ 150 mm			

*In case of intermediate strokes from the standard strokes (see table below), the cylinder body will have the overall dimensions of the cylinder with the next standard stroke, as desired stroke is obtained by applying a spacer.

Standard strokes

Stroke mm	GEDB Bore Ø mm											
	6	10	12	16	20	25	32	40	50	63	80	100
5												
10												
15												
20												
25												
30												
40												
50												
75												
100												
125												
150												
175												
200												
250												

Stroke mm	GEDS Bore Ø mm									
	12	16	20	25	32	40	50	63	80	100
5										
10										
15										
20										
25										
30										
40										
50										
75										
100										
125										
150										
175										
200										
250										

Key
 Standard stroke

Theoretical thrust force

Unit: N

1 - CYLINDERS

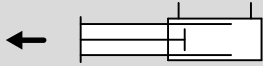

Ø Cylinder (mm)	Ø Rod (mm)	Cylinder Area (cm²)	Pressure range (bar)						
			1	2	3	4	5	6	7
6	3	0,28	-	5	8	11	14	17	20
10	5	0,79	-	15	23	31	39	47	55
12	6	1,13	-	23	34	45	57	68	79
16	8	2,01	-	40	60	80	101	121	140
20	10	3,14	-	60	90	120	150	180	210
25	12	4,90	-	90	140	190	240	290	340
32	16	8,04	-	160	240	320	400	480	550
40	16	12,56	120	250	370	500	620	750	870
50	20	19,63	190	390	580	780	980	1170	1370
63	20	31,17	310	620	930	1240	1550	1870	2180
80	25	50,20	502	1005	1507	2010	2512	3014	3517
100	25	78,50	785	1570	2355	3140	3925	4710	5495

Theoretical traction force

Unit: N



Ø Cylinder (mm)	Ø Rod (mm)	Cylinder Area (cm²)	Pressure range (bar)						
			1	2	3	4	5	6	7
6	3	0,21	-	4	6	8	10	13	15
10	5	0,59	-	11	17	23	29	35	41
12	6	0,85	-	17	25	34	42	51	59
16	8	1,51	-	30	45	60	76	91	106
20	10	2,35	-	47	71	94	118	141	165
25	12	3,77	-	75	113	151	189	226	263
32	16	6,03	-	121	181	242	302	362	422
40	16	10,55	100	210	310	420	520	630	730
50	20	16,49	160	320	490	650	820	980	1150
63	20	28,03	280	560	840	1120	1400	1680	1960
80	25	45,30	453	907	1360	1813	2267	2720	3173
100	25	73,60	736	1472	2208	2944	3680	4416	5152

Admissible transverse load

Unit: N

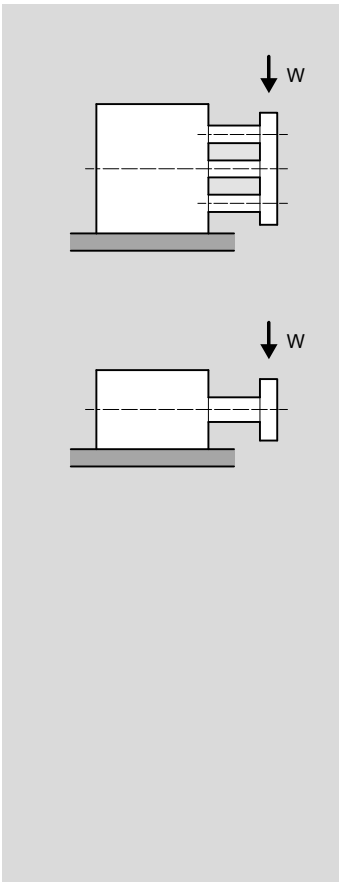

Series	Ø (mm)	Stroke (mm)											
		5	10	15	20	25	30	40	50	75	100	125	150
GEDB	6	0,72	0,61	0,51	-	-	-	-	-	-	-	-	-
GEDS		-	-	-	-	-	-	-	-	-	-	-	-
GEDB	10	2,45	2,05	1,70	1,50	-	-	-	-	-	-	-	-
GEDS		-	-	-	-	-	-	-	-	-	-	-	-
GEDB	12	-	21,0	-	18,0	-	15,0	13,0	12,0	9,0	8,0	-	-
GEDS		-	-	27,0	-	22,0	-	17,0	21,0	19,0	15,0	13,0	-
GEDB	16	-	-	-	-	26,0	-	-	19,0	15,0	13,0	27,0	24,0
GEDS		-	-	-	-	28,0	-	-	33,0	28,0	23,0	20,0	17,0
GEDB	20	-	-	-	-	48,0	-	-	34,0	57,0	49,0	42,0	37,0
GEDS		-	-	-	-	49,0	-	-	65,0	53,0	44,0	30,0	26,0
GEDB	25	-	-	-	-	70,0	-	-	47,0	77,0	65,0	56,0	49,0
GEDS		-	-	-	-	71,0	-	-	72,0	59,0	51,0	42,0	36,0
GEDB	32	-	-	-	-	-	200	-	180	179	156	138	124
GEDS		-	-	-	-	-	-	160	-	120	190	159	123
GEDB	40	-	-	-	-	-	200	-	180	179	156	138	124
GEDS		-	-	-	-	-	-	160	-	120	190	159	123
GEDB	50	-	-	-	-	-	330	-	286	292	257	230	208
GEDS		-	-	-	-	-	-	170	-	129	215	181	139
GEDB	63	-	-	-	-	-	330	-	286	292	257	230	208
GEDS		-	-	-	-	-	-	170	-	129	215	181	139
GEDB	80	-	-	-	-	370	-	-	304	345	309	280	256
GEDS		-	-	-	-	235	-	-	157	263	226	199	178
GEDB	100	-	-	-	-	539	-	-	470	412	343	278	252
GEDS		-	-	-	-	470	-	-	313	400	332	261	206

1 - CYLINDERS

Maximum admissible torque

Unit: N·m

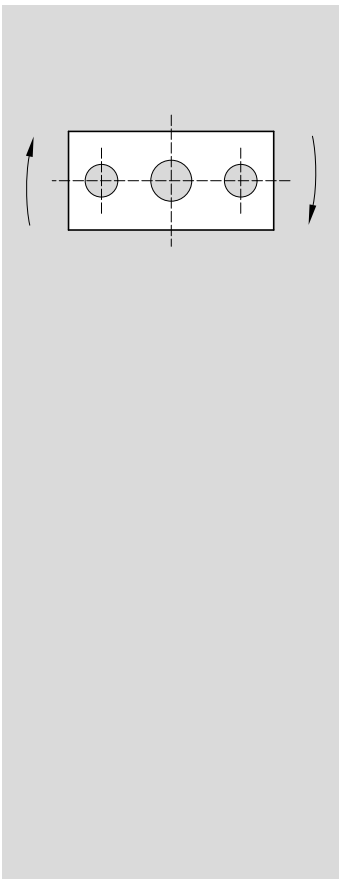

Series	Ø (mm)	Stroke (mm)											
		5	10	15	20	25	30	40	50	75	100	125	150
GEDB	6	0,09	0,073	0,061	-	-	-	-	-	-	-	-	-
GEDS		-	-	-	-	-	-	-	-	-	-	-	-
GEDB	10	0,47	0,39	0,33	0,28	-	-	-	-	-	-	-	-
GEDS		-	-	-	-	-	-	-	-	-	-	-	-
GEDB	12	-	0,40	-	0,30	-	0,28	0,25	0,22	0,45	0,37	-	-
GEDS		-	-	0,54	-	0,42	-	0,35	0,30	0,27	0,50	0,42	-
GEDB	16	-	-	-	-	0,50	-	-	0,36	0,65	0,55	0,40	0,35
GEDS		-	-	-	-	0,70	-	-	0,44	0,82	0,70	0,62	0,58
GEDB	20	-	-	-	-	1,02	-	-	0,78	1,95	1,69	1,49	1,28
GEDS		-	-	-	-	1,28	-	-	0,95	2,23	1,91	1,68	1,47
GEDB	25	-	-	-	-	1,70	-	-	1,31	2,96	2,57	2,26	2,02
GEDS		-	-	-	-	1,35	-	-	1,03	2,42	2,07	1,82	1,60
GEDB	32	-	-	-	-	-	20,0	-	18,0	17,9	15,6	13,8	12,4
GEDS		-	-	-	-	-	-	16,0	-	12,0	19,0	15,9	12,3
GEDB	40	-	-	-	-	-	7,10	-	6,42	5,80	6,30	5,50	4,90
GEDS		-	-	-	-	-	-	3,87	-	3,50	3,10	6,70	5,80
GEDB	50	-	-	-	-	-	13,6	-	11,4	11,9	10,5	9,40	8,50
GEDS		-	-	-	-	-	-	5,80	-	4,80	9,30	8,20	7,30
GEDB	63	-	-	-	-	-	15,0	-	12,5	13,1	11,6	10,4	9,40
GEDS		-	-	-	-	-	-	6,40	-	5,30	10,3	9,10	8,10
GEDB	80	-	-	-	-	21,0	-	-	18,0	23,0	21,0	19,0	18,0
GEDS		-	-	-	-	15,0	-	-	23,0	22,0	20,0	18,0	16,0
GEDB	100	-	-	-	-	38,0	-	-	33,0	38,0	33,0	30,0	28,0
GEDS		-	-	-	-	27,0	-	-	30,0	37,0	34,0	31,0	29,0

Non-rotating accuracy

1 - CYLINDERS

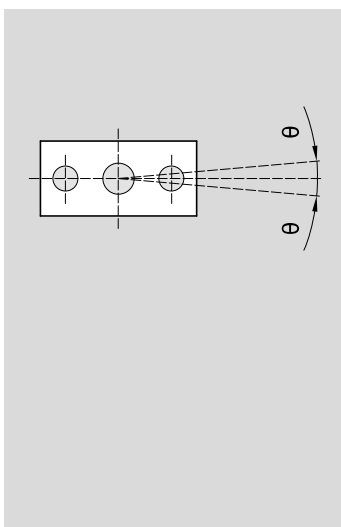

Series	Ø (mm)	Non-rotating accuracy μ
GEDB	6 ÷ 10	±0.2
GEDB	12 ÷ 16	±0.18
GEDS		
GEDB	20 ÷ 25	±0.17
GEDS		
GEDB	32 ÷ 40	±0.16
GEDS		
GEDB	50 ÷ 63	±0.15
GEDS		
GEDB	80 ÷ 100	±0.1
GEDS		

Dimensions

Type: **GEDB**
Ø 6

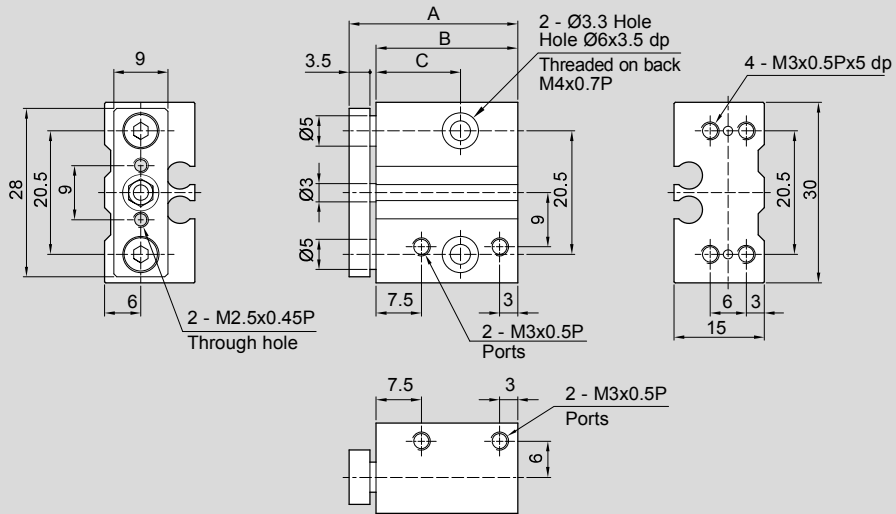

stroke (mm)	5	10	15
A	28	33	38
B	23,5	28,5	33,5
C	14	19	24

Dimensions

Type: **GEDB**
Ø 10

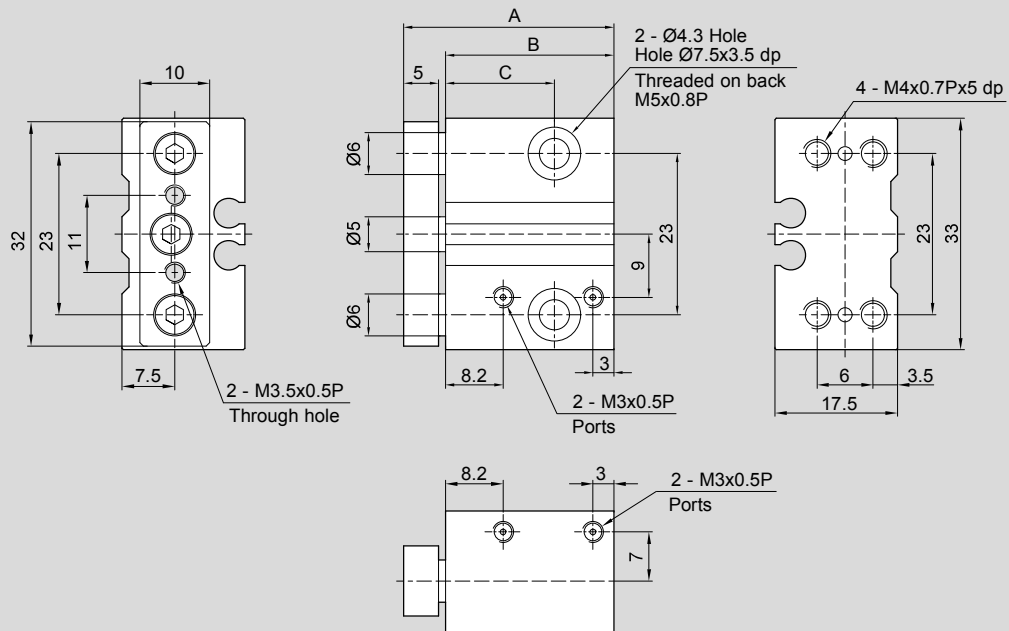

stroke (mm)	5	10	15	20
A	30	35	40	45
B	24	29	34	39
C	15,5	20,5	25,5	30,5

Dimensions

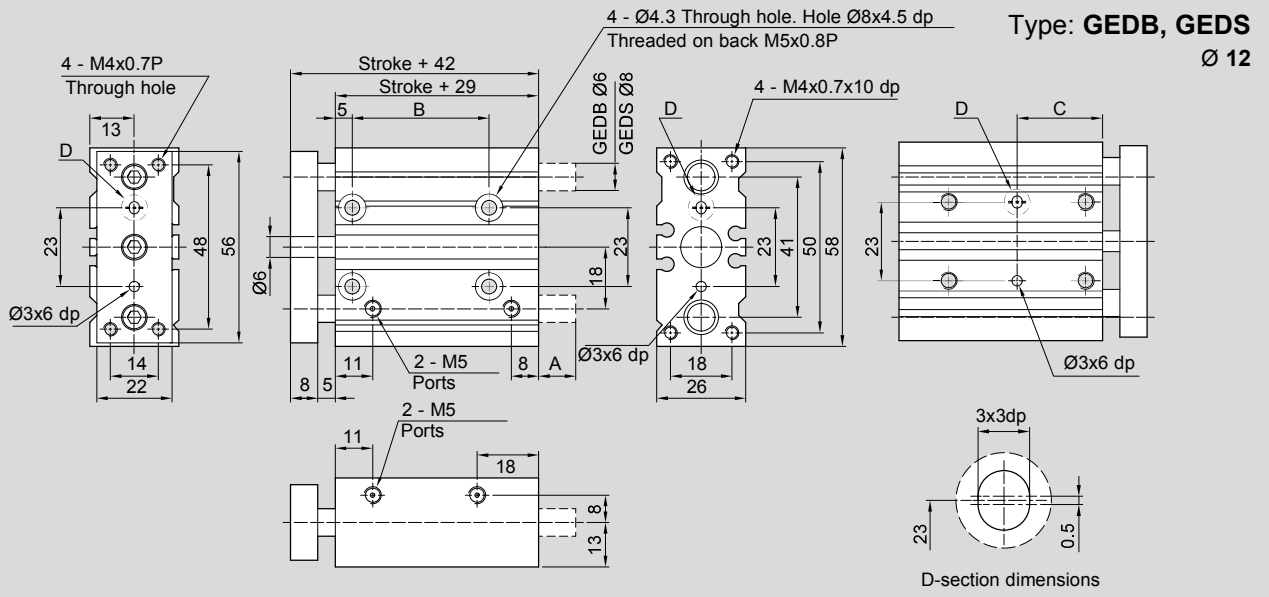

stroke (mm)	10	20	30	40	50	75	100
A	0	0	0	0	0	18,5	18,5
B	20	20	20	40	40	40	40
C	15	15	15	25	25	25	25

Dimensions

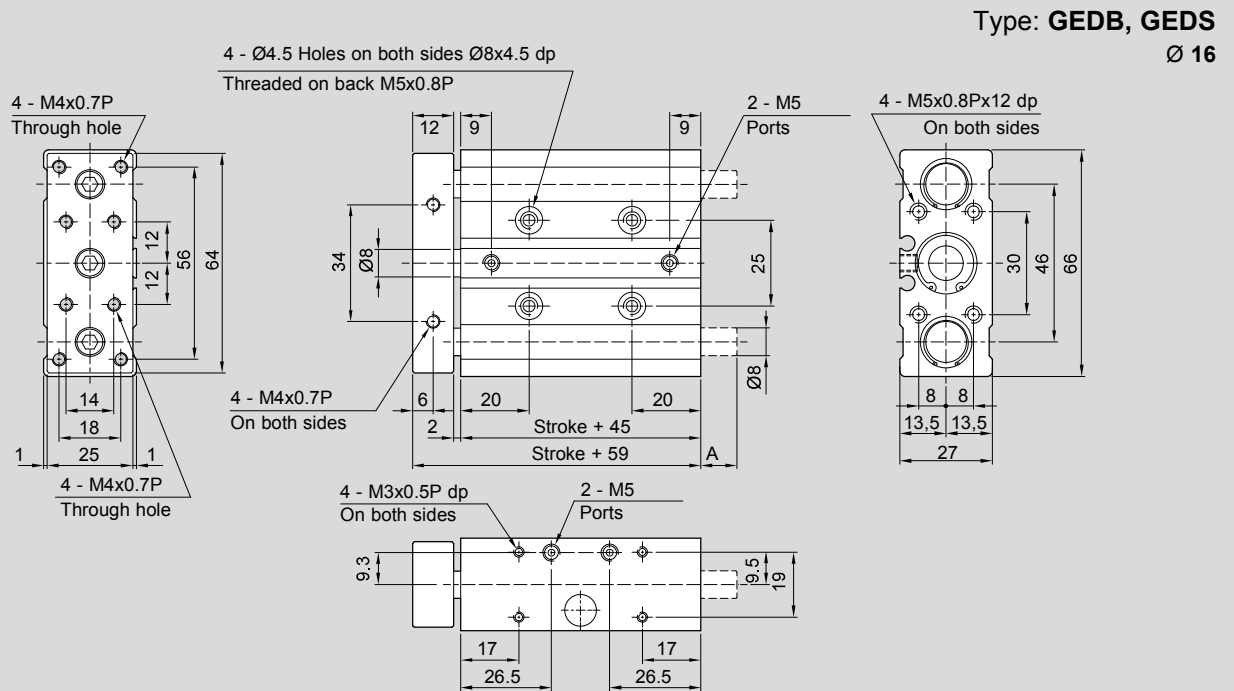

stroke (mm)	25	50	75	100	125	150	175	200
A	0	0	11,5	11,5	11,5	11,5	11,5	11,5

Dimensions

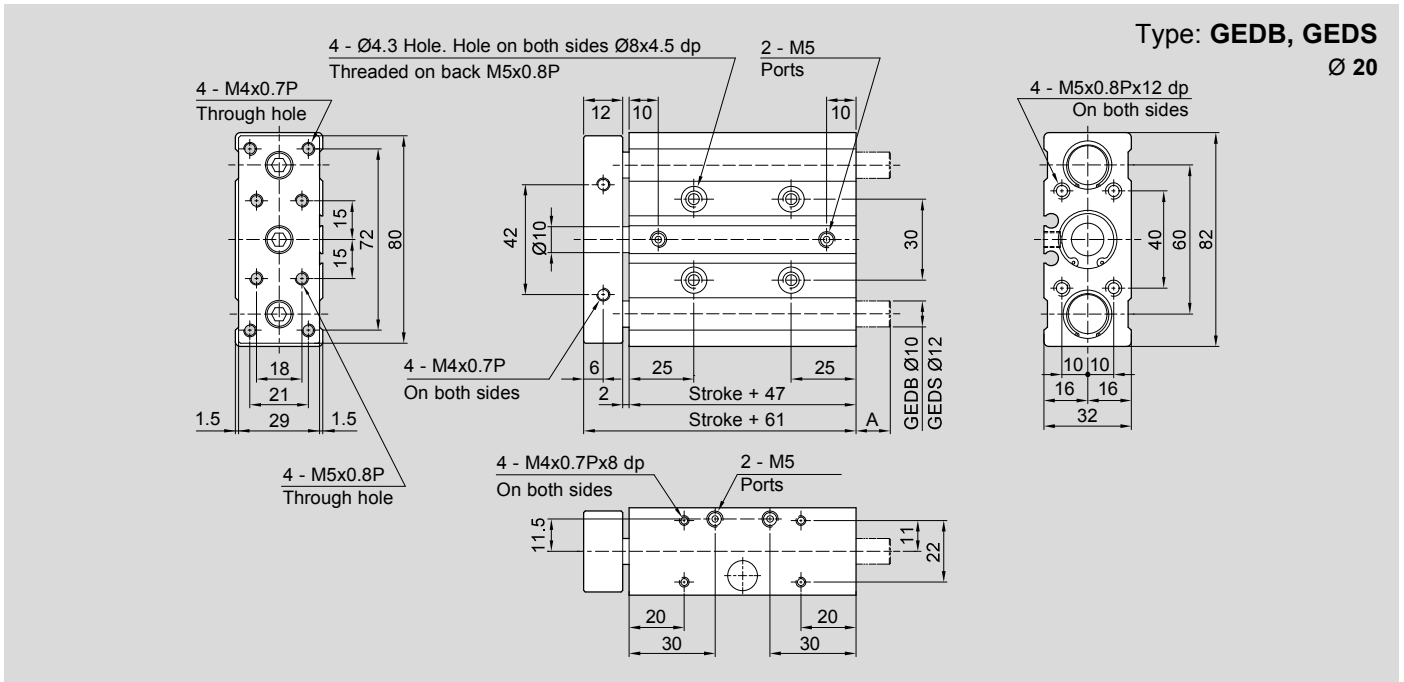

stroke (mm)	25	50	75	100	125	150	175	200
A	0	0	14,9	14,9	14,9	14,9	14,9	14,9

Dimensions

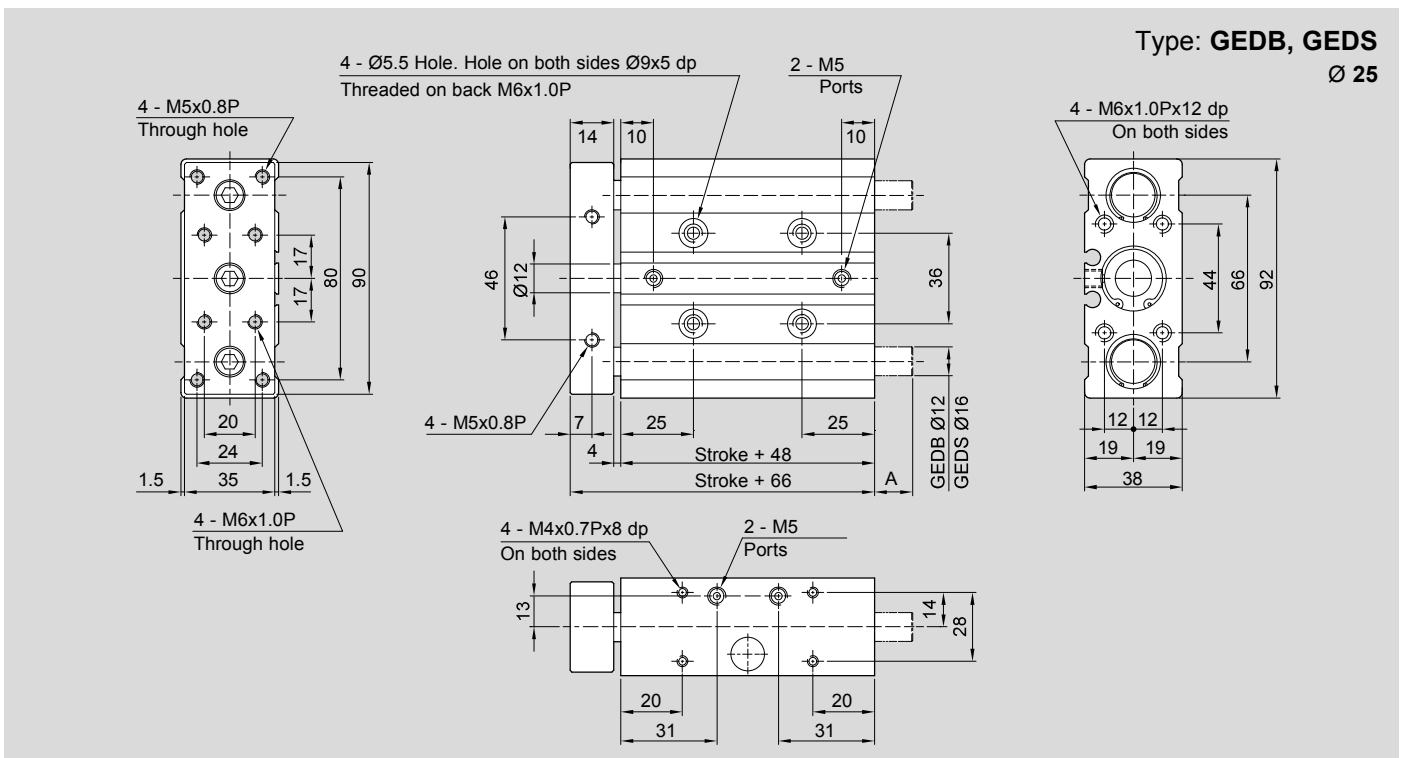

stroke (mm)	25	50	75	100	125	150	175	200
A	0	0	11	11	11	11	11	11

Dimensions

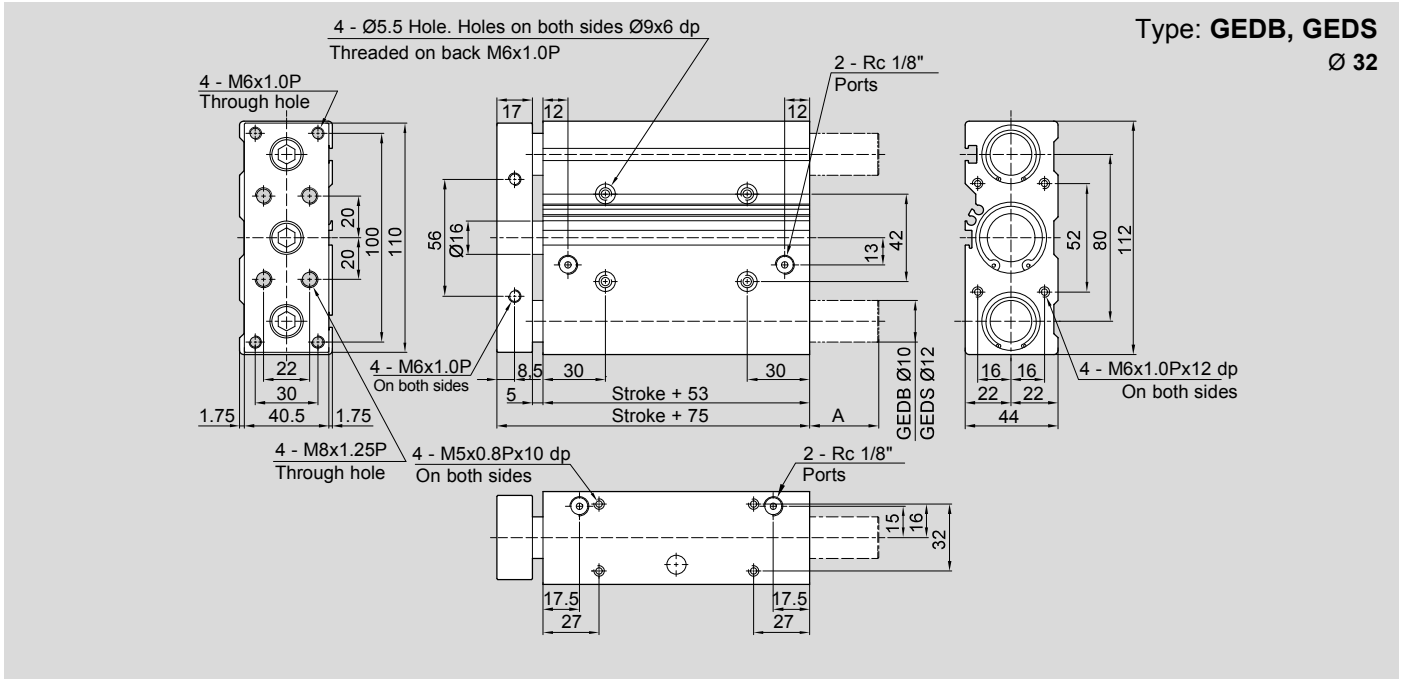

stroke (mm)	30	50	75	100	125	150	175	200	250
A	0	0	34	34	34	34	34	34	34

Dimensions

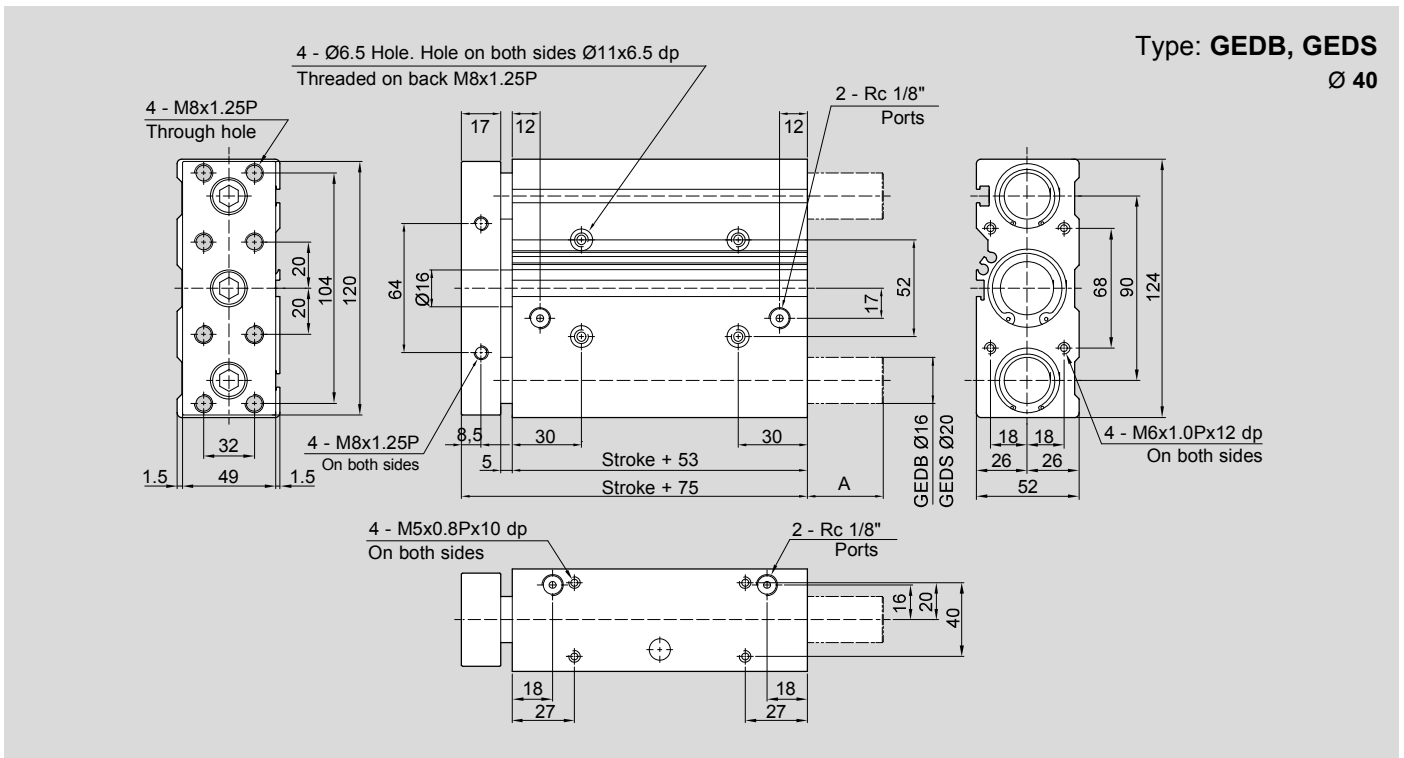

stroke (mm)	30	50	75	100	125	150	175	200	250
A	0	0	33	33	33	33	33	33	33

Dimensions

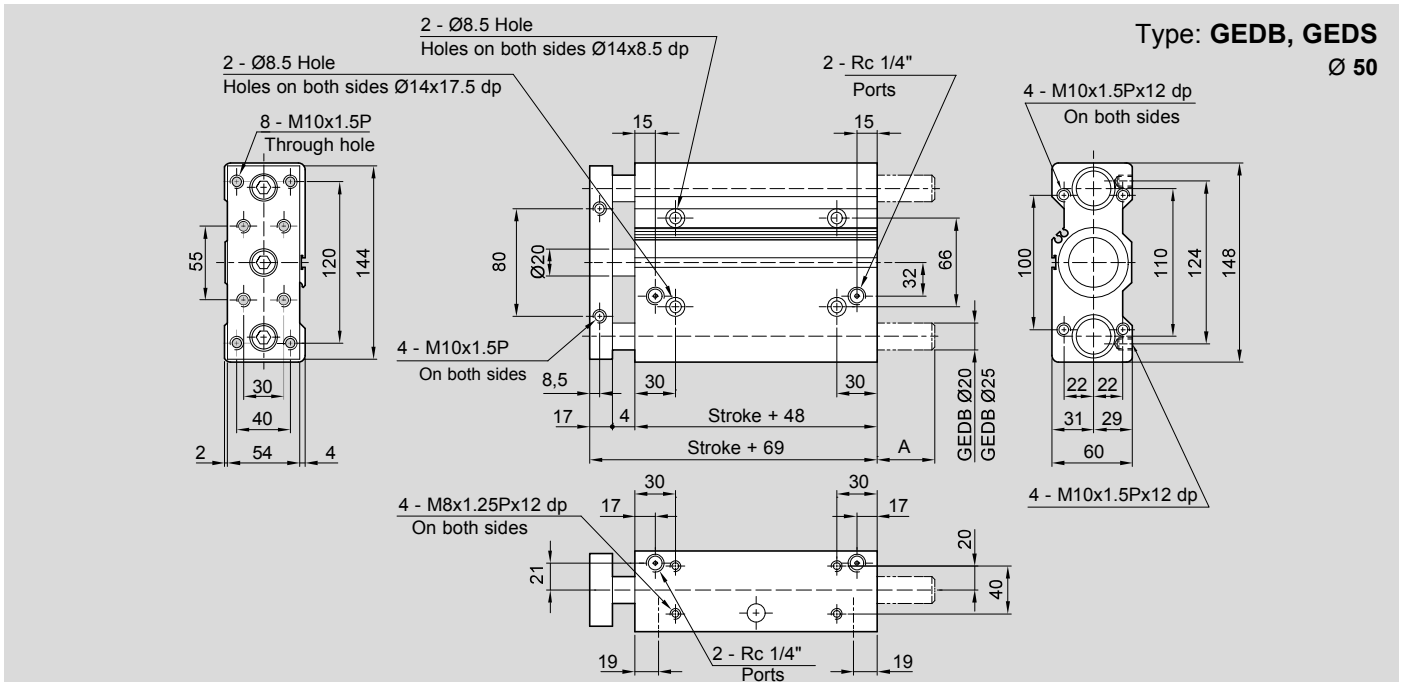

stroke (mm)	30	50	75	100	125	150
A	0	0	0	49	49	49

Dimensions

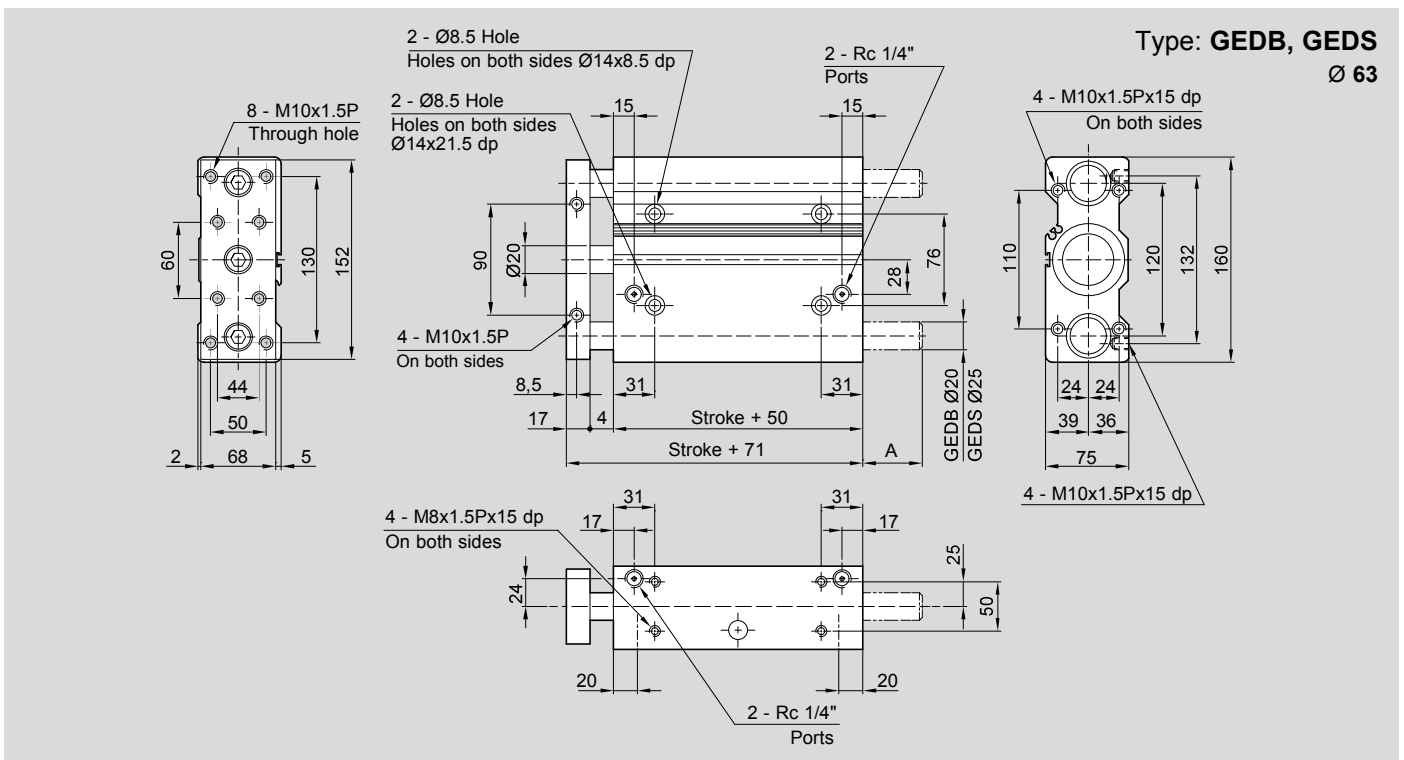

stroke (mm)	30	50	75	100	125	150
A	0	0	0	47	47	47

Dimensions

Type: **GEDB, GEDS**
Ø 80

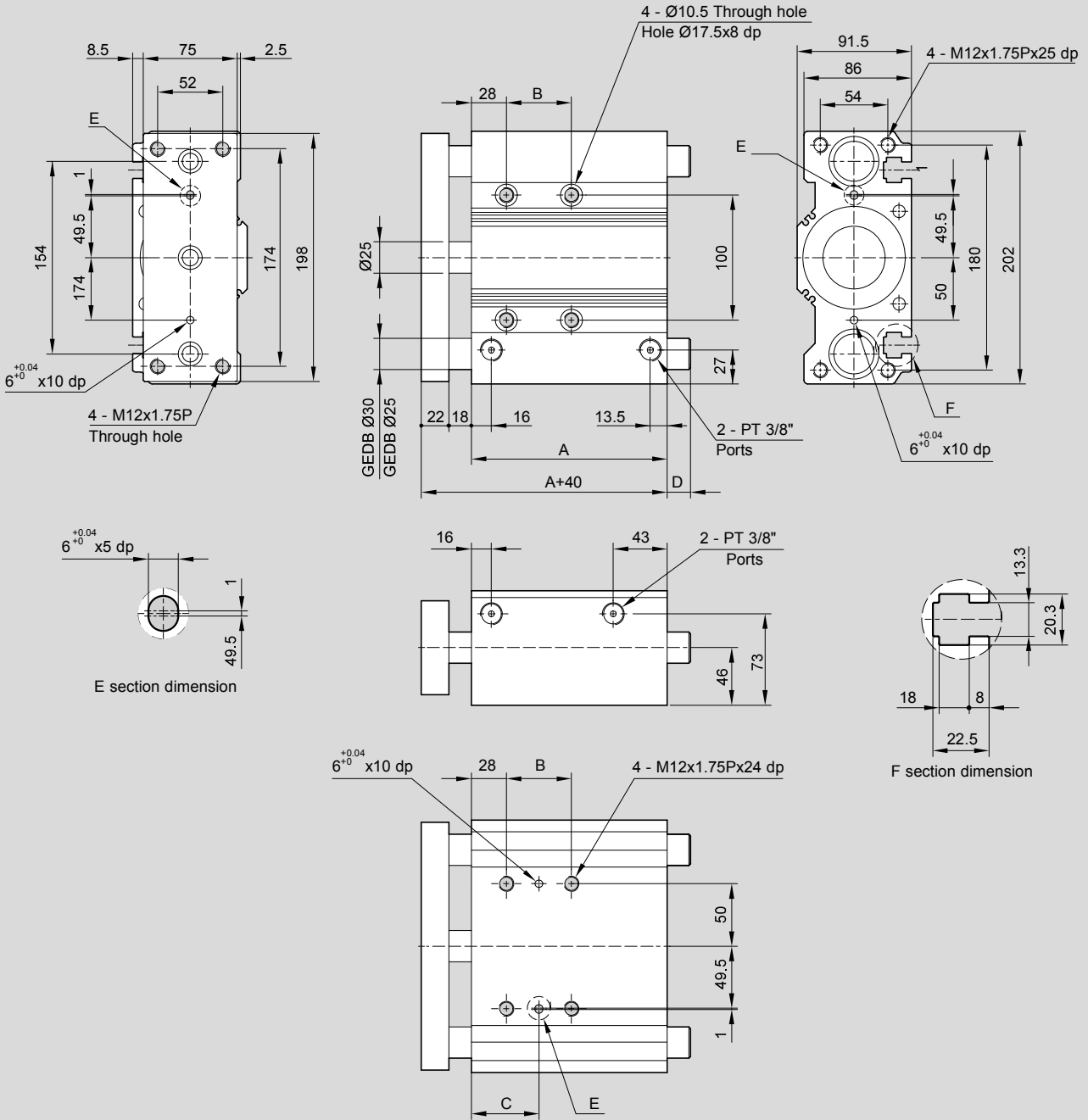

stroke (mm)	30	50	75	100	125	150
A	81,5	106,5	131,5	156,5	181,5	206,5
B	28	52	52	52	128	128
C	42	54	54	54	92	92
D	10	10	63	63	63	63

Dimensions

Type: **GEDB, GEDS**
Ø 100

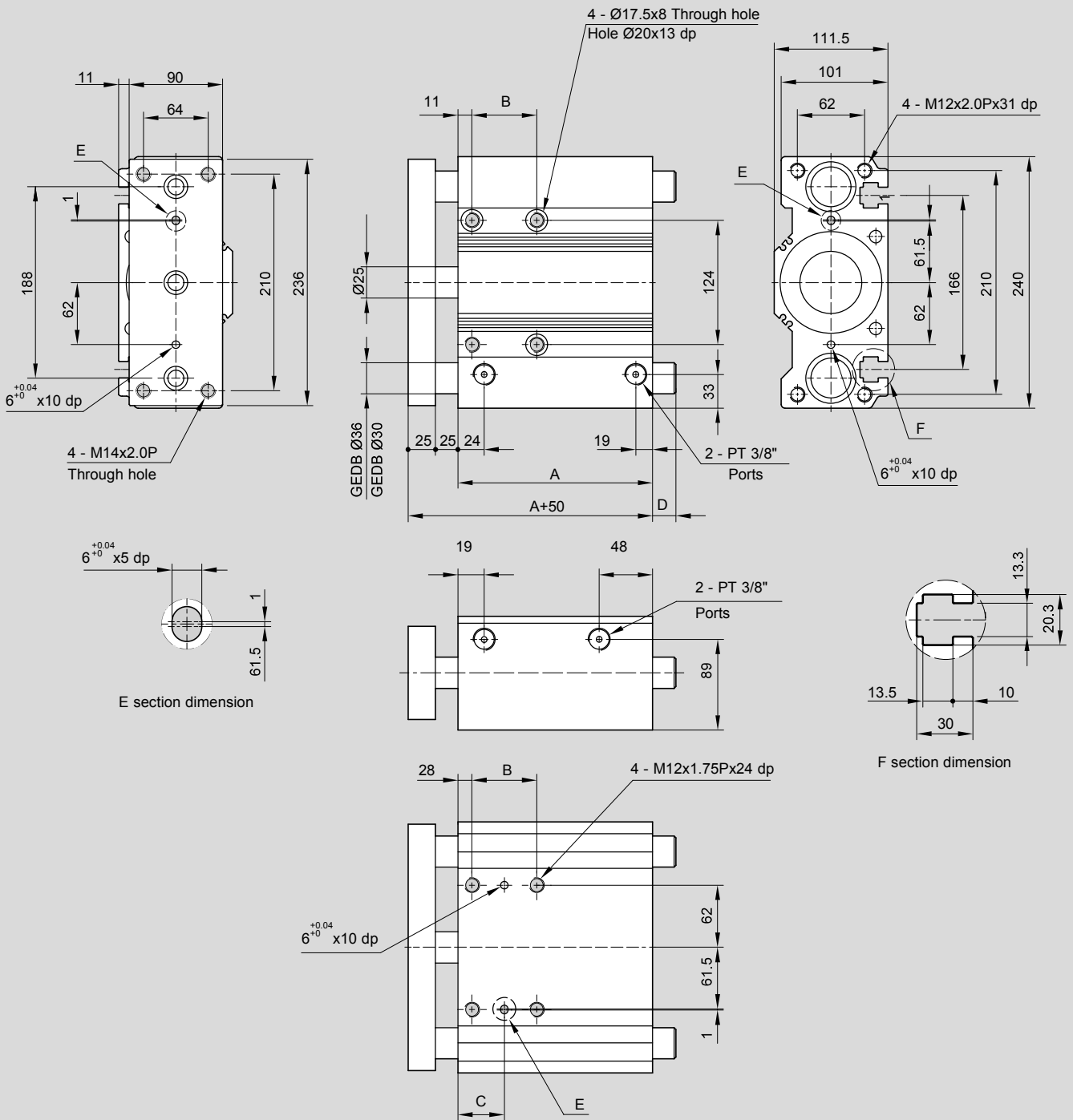

1 - CYLINDERS

stroke (mm)	30	50	75	100	125	150
A	91	116	141	166	191	216
B	48	72	72	72	148	148
C	35	47	47	47	85	85
D	5	5	64	64	64	64

Main features

12 ÷ 63

Bores Ø

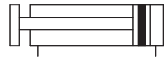

Double acting
Magnetic
With self-lubricating
bushings

GPB

Type



12 ÷ 63

Bores Ø

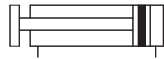

Double acting
Magnetic
With spherical
bearings

GPS

Type



Technical data

Bore Ø mm	12	16	20	25	32	40	50	63
Fluid	Filtered compressed air with or without lubrication. Lubrication, if started, must be continued.							
Pressure range	2 ÷ 7 bar							
Temperature range	-10°C ÷ +60°C							
Speed	50 ÷ 500 mm/s						50 ÷ 350 mm/s	
Port	M5		1/8"			1/4"		
Strokes*	10 ÷ 100 mm		20 ÷ 175 mm		25 ÷ 150 mm			

*In case of intermediate strokes from the standard strokes (see table below), the cylinder body will have the overall dimensions of the cylinder with the next standard stroke, as desired stroke is obtained by applying a spacer.

Standard strokes

Stroke mm	GPB Bore Ø mm							
	12	16	20	25	32	40	50	63
10								
20								
25								
30								
40								
50								
75								
100								
125								
150								
175								

Stroke mm	GPS Bore Ø mm							
	12	16	20	25	32	40	50	63
10								
20								
25								
30								
40								
50								
75								
100								
125								
150								
175								

Key
 Standard stroke

Theoretical thrust force

Unit: N

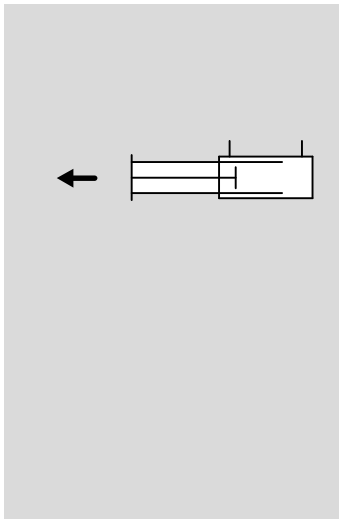

Ø Cylinder (mm)	Ø Rod (mm)	Cylinder Area (cm ²)	Pressure range (bar)					
			2	3	4	5	6	7
12	6	1,13	23	34	45	57	68	79
16	8	2,01	40	60	80	101	121	141
20	10	3,14	63	94	126	157	188	220
25	12	4,91	98	147	196	245	295	344
32	16	8,04	161	241	322	402	483	563
40	16	12,57	251	377	503	628	754	880
50	20	19,63	393	589	785	982	1178	1374
63	20	31,17	623	935	1247	1559	1870	2182

Theoretical traction force

Unit: N

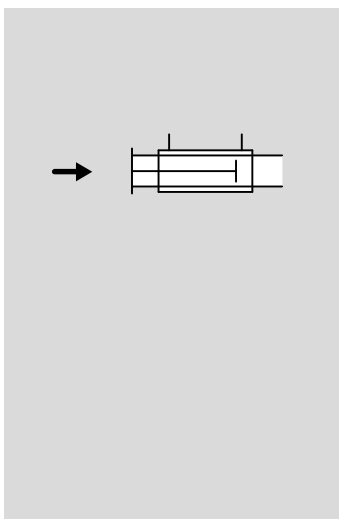

Ø Cylinder (mm)	Ø Rod (mm)	Cylinder Area (cm ²)	Pressure range (bar)					
			2	3	4	5	6	7
12	6	1,13	17	25	34	42	51	59
16	8	2,01	30	45	60	75	90	106
20	10	3,14	47	71	94	118	141	165
25	12	4,91	76	113	151	189	227	264
32	16	8,04	121	181	241	302	362	422
40	16	12,57	211	317	422	528	633	739
50	20	19,63	330	495	660	825	990	1155
63	20	31,17	561	841	1121	1402	1682	1962

Dimensions

Type: **GPB, GPS**
Ø 12 ÷ 25

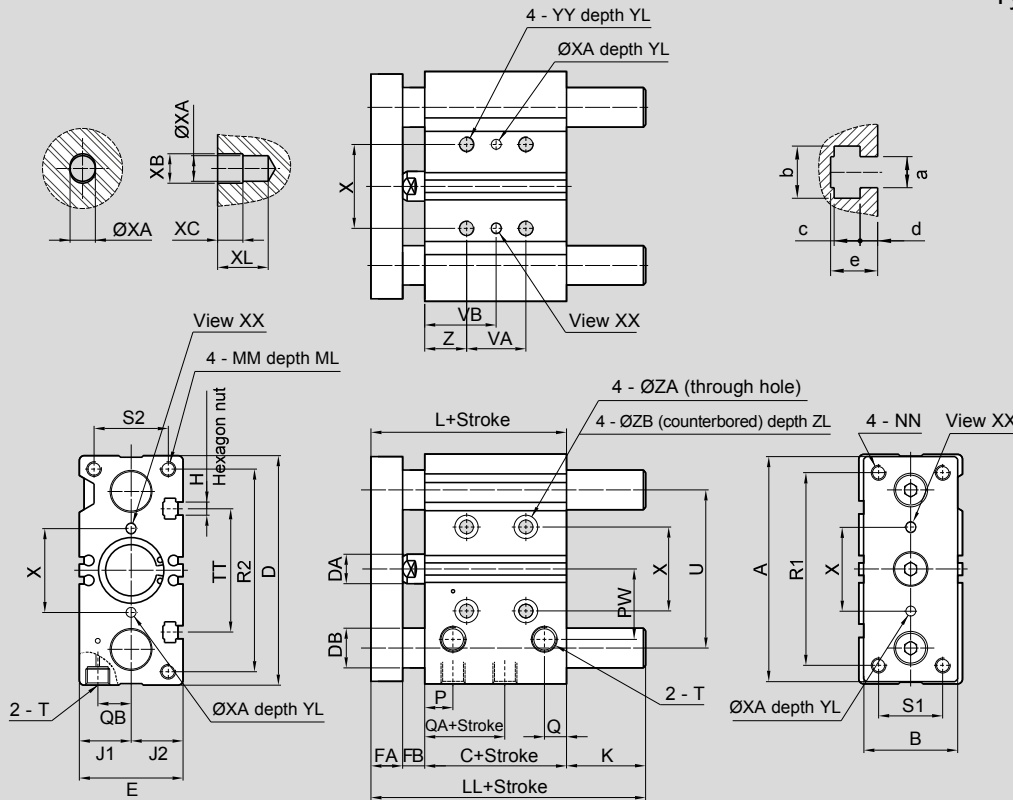

Ø (mm)	A	B	C	D	DA	DB		E	FA	FB	H	J ₁	J ₂	L	MM	ML	NN	T	P	Q	a	b	c	d	e
						GPB	GPS																		
12	56	22	29	58	6	8	6	26	8	5	M4	13	13	42	M4	10	M4	M5	11	7.5	4,4	7,4	3,7	2	6,2
16	62	25	33	64	8	10	8	30	8	5	M4	15	15	46	M5	12	M5	M5	11	8	4,4	7,4	3,7	2,5	6,7
20	81	30	37	83	10	12	10	36	10	6	M5	18	18	53	M5	13	M5	1/8"	11.5	9	5,4	8,4	4,5	2,3	7,3
25	91	38	37.5	93	12	16	12	42	10	6	M5	21	21	53.5	M6	15	M6	1/8"	11.5	9	5,4	8,4	4,5	3	8,2

Ø (mm)	QA	QB	PW	TT	U	VA			VB			S ₁	S ₂	R ₁	R ₂	X ±0,02	XA H ₇	XB	XC
						stroke 10÷30	stroke 40÷100	stroke 125÷175	stroke 10÷30	stroke 40÷100	stroke 125÷175								
12	12	7.5	18	37	41	20	40	-	15	25	-	14	18	48	50	23	3	3.5	3
16	14	10	19	38	46	24	44	-	17	27	-	16	22	54	56	24	3	3.5	3
20	12.5	11.5	25	44	54	24	44	120	29	39	77	18	24	70	72	28	3	3.5	3
25	12.5	13.5	28.5	50	64	24	44	120	29	39	77	26	30	78	82	34	4	4.5	3

Ø (mm)	XL	YY	YL	Z	ZA	ZB	ZL	K					LL				
								GPB		GPS			GPB		GPS		
								stroke 10÷50	stroke 75÷100	stroke 10÷30	stroke 40÷100	stroke 125÷175	stroke 10÷50	stroke 75÷100	stroke 10÷30	stroke 40÷100	stroke 125÷175
12	6	M5	10	5	4.3	8	4.5	0	15	0	15	-	42	57	42	57	-
16	6	M5	10	5	4.3	8	4.5	0	22	0	22	-	46	68	46	68	-
20	6	M6	12	17	5.6	9.5	5	0	28	0	28	52	53	81	53	81	105
25	6	M6	12	17	5.6	9.5	5.5	0	29	0	31	50	53.5	82.5	53.5	84.5	103.5

Dimensions

Type: **GPB, GPS**
Ø 32 ÷ 63

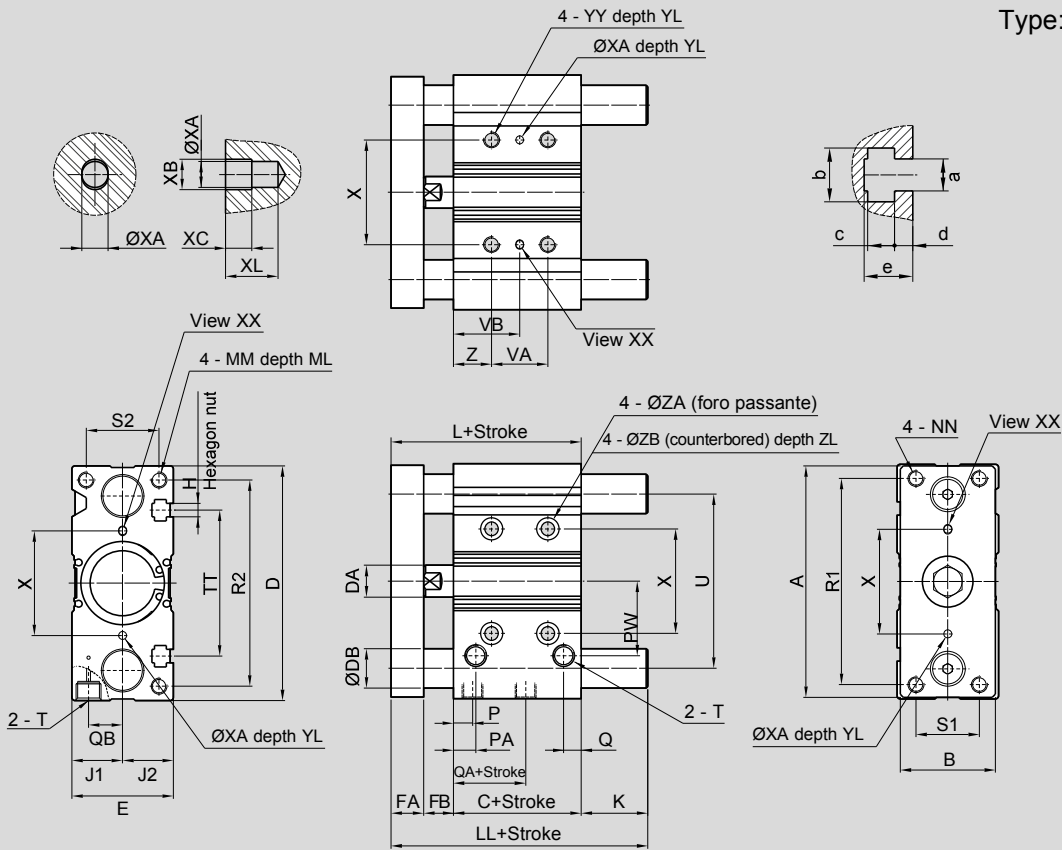



Ø (mm)	A	B	C	D	DA	DB		E	FA	FB	H	J ₁	J ₂	L	MM	ML	NN	T	P	Q	a	b	c	d	e
						GPB	GPS																		
32	110	44	37.5	112	16	20	16	48	12	10	M6	24	24	59.5	M8	20	M8	1/8"	11.5	10	6.5	10.5	5.35	3.5	9.5
40	118	44	44	120	16	20	16	54	12	10	M6	27	27	66	M8	20	M8	1/8"	14	11	6.5	10.5	5.35	4	11
50	146	60	44	148	20	25	20	64	16	12	M8	32	32	72	M10	22	M10	1/4"	12	11	8.5	13.5	7.5	4.5	13.5
63	158	70	49	162	20	25	20	78	16	12	M10	39	39	77	M10	22	M10	1/4"	16.5	13	11	17.8	10	7	18.5

Ø (mm)	QA	QB	PA	PW	TT	U	VB						S ₁	S ₂	R ₁	R ₂	X ±0.02	XA H ₁	XB
							stroke	stroke	stroke	stroke	stroke	stroke							
							25÷40	50÷100	125÷175	25÷40	50÷100	125÷175							
32	5	16.5	11.5	34	63	78	24	48	124	33	45	83	30	34	96	98	42	4	4.5
40	11	18	14	38	72	86	24	48	124	34	46	84	30	40	104	106	50	4	4.5
50	9	21.5	14	47	92	110	24	48	124	36	48	86	40	46	130	130	66	5	6
63	14	28	16.5	55	110	124	28	52	128	38	50	88	50	58	130	142	80	5	6

Ø (mm)	XC	XL	YY	YL	Z	ZA	ZB	ZL	K						LL					
									GPB			GPS			GPB		GPS			
									stroke	stroke	stroke	stroke	stroke	stroke	stroke	stroke	stroke	stroke	stroke	stroke
									25÷50	75÷175	25÷50	75÷100	125÷175	25÷50	75÷175	25÷50	75÷175	25÷50	75÷100	125÷175
32	3	6	M8	16	21	6.5	11	7.5	8	45	8	45	65	67.5	104.5	67.5	104.5	124.5		
40	3	6	M8	16	22	6.5	11	7.5	1.5	38.5	1.5	38.5	58.5	67.5	104.5	67.5	104.5	124.5		
50	4	8	M10	20	24	8.5	14	9	6.5	48.5	6.5	48.5	68.5	78.5	120.5	78.5	120.5	140.5		
63	4	8	M10	20	24	8.5	14	9	1.5	43.5	1.5	43.5	63.5	78.5	120.5	78.5	120.5	140.5		

Magnetic reed switch C groove ASC..

	For cylinder Ø mm	Code	Item	Cylinder matching
	6 ÷ 100	070248 	ASC1C525	GEDB
		070249	ASC7N2M8	GEDS
		070382	ASC7M2M8	GPB GPS

TWIN ROD

Cylinders



Find out our
key products



Solution for most applications



Easy and intuitive choice



Excellent value for money



Wide availability



Fast delivery



Features and certifications

Series of twin rod cylinders, available in bores from Ø 6 to 32, double acting, magnetic, with self-lubricating bushings or with spherical bearings. These cylinders are of double rod with double thrust force and smooth and precise operation. Supplied as standard in compliance with Reach and RoHS directives.



Type GSB Ø 6 ÷ 32 from page 1.24.20



Twin rod cylinders, available in bores from Ø 6 to 32, double acting, magnetic, with self-lubricating bushings . These cylinders are double rod with double thrust force and smooth and precise operation. The extruded body is machined with grooves allowing the mounting of magnetic reed switches directly, not protruding beyond the profile of the cylinder, and elastic dampers on front and end covers.

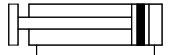

Type GSS Ø 6 ÷ 32 from page 1.24.20



Twin rod cylinders, available in bores from Ø 6 to 32, double acting, magnetic, with spherical bearings. These cylinders are double rod with double thrust force and smooth and precise operation. The extruded body is machined with grooves allowing the mounting of magnetic reed switches directly, not protruding beyond the profile of the cylinder, and elastic dampers on front and end covers.

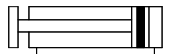

Options

Description	Symbol	Suffix
Special versions on request		/S

Code key

Bore	/	Stroke	Type	/	Special version
32	/	50	GSB	/	

Ø 6, 10, 16, 20, 25, 32

See table on page 1.24.20

GSB
Double acting
Magnetic
With self-lubricating bushings

GSS
Double acting
Magnetic
With spherical bearings

S

How to order

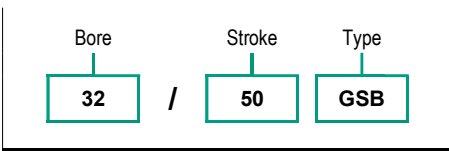

Notes

For further information on options see the table above.

Standard materials

Type: **GSB, GSS**

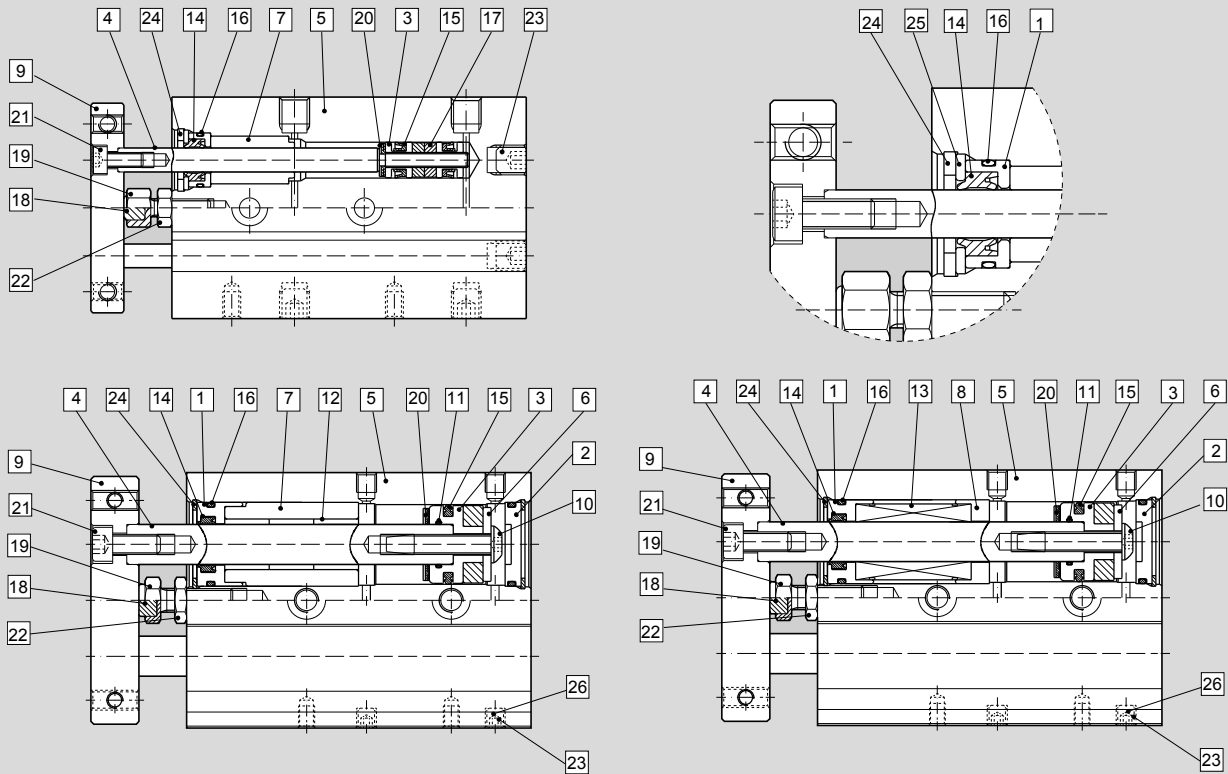

Position	Description	Materials					
		GSB			GSS		
		Ø 6	Ø 10	Ø 16 ÷ 32	Ø 6	Ø 10	Ø 16 ÷ 32
1	Front head cover	Hard anodised aluminium					
2	Rear covers	Hard anodised aluminium					
3	Piston	Brass	Aluminium		Brass	Aluminium	
4	Piston rod	Stainless Steel		Carbon steel	Special steel		
5	Cylinder barrel	Hard anodised aluminium					
6	Magnet holder	Stainless Steel					
7	Support	Brass	Aluminium		Brass	Aluminium	
8	Support	Brass	Aluminium		Brass	Aluminium	
9	Guide plate	Hard anodised aluminium					
10	Nut	Nickel-plated carbon steel					
11	O-ring	NBR					
12	Oilless bearing	Oil-impregnated sintered alloy					
13	Linear bearing	Special steel					
14	Rod packing	Polyurethane (PU)					
15	Piston packing	NBR					
16	Cylinder gasket	NBR					
17	Magnet	Magnetic material					
18	Elastic dampers	NBR					
19	Adjusting screw	Stainless Steel					
20	Rubber lining	NBR					
21	Screw	Nickel-plated carbon steel					
22	Lock nut	Nickel-plated carbon steel					
23	Seat screw	Carbon steel					
24	Retaining ring	Nickel-plated carbon steel					
25	Steel pad	Stainless Steel					
26	Port gasket	NBR					

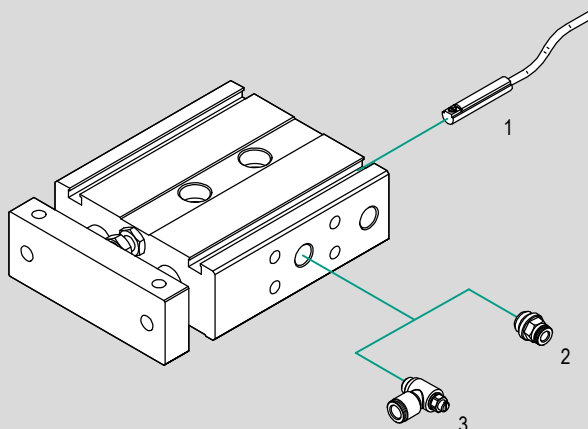

N.	Cylinder bore	Item	Description	Compliance	Matching		Code page	Data sheet page
					GSB	GSS		
1	Ø 6 ÷ 32	ASV..	Magnetic reed switch T groove	-	●	●	1.24.90	1.110.10
2	Ø 6 ÷ 32	R..	Push-in fittings		●	●	4.2.1	
3	Ø 6 ÷ 32	V..C	Flow controls, for cylinders		●	●	4.94.1	

Key

● matching accessory; - not matching accessory

Twin Rod Cylinders

Series GSB - GSS



1 - CYLINDERS

Main features

6 ÷ 32

Bores Ø

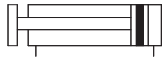

Double acting
Magnetic
With self-lubricating bushings

GSB

Type



6 ÷ 32

Bores Ø

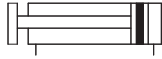

Double acting
Magnetic
With spherical bearings

GSS

Type



Technical data

Bore Ø mm	6	10	16	20	25	32
Fluid	Filtered compressed air with or without lubrication. Lubrication, if started, must be continued.					
Pressure range	1,5 ÷ 7 bar	1 ÷ 7 bar		0,5 ÷ 7 bar		
Temperature range	-10°C ÷ +60°C					
Speed	30 ÷ 300 mm/s		30 ÷ 500 mm/s			
Port	M5				1/8"	
Strokes*	10 ÷ 50 mm		10 ÷ 150 mm			
Adjustable stroke	0 ÷ -5 mm					

Standard strokes

Stroke mm	GSB Bore Ø mm					
	6	10	16	20	25	32
10						
15						
20						
25						
30						
35						
40						
45						
50						
60						
70						
75						
80						
90						
100						
125						
150						

Stroke mm	GSS Bore Ø mm					
	6	10	16	20	25	32
10						
15						
20						
25						
30						
35						
40						
45						
50						
60						
70						
75						
80						
90						
100						
125						
150						

Key
 Standard stroke

Dimensions

Type: **GSB, GSS**
Ø 6

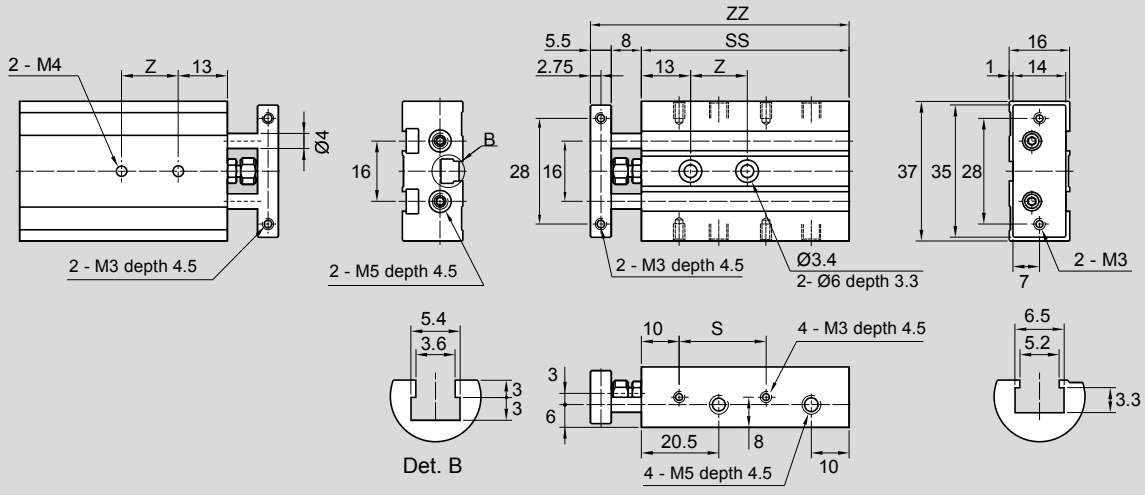

Ø (mm)	S					Z					SS					ZZ				
	stroke 10	stroke 20	stroke 30	stroke 40	stroke 50	stroke 10	stroke 20	stroke 30	stroke 40	stroke 50	stroke 10	stroke 20	stroke 30	stroke 40	stroke 50	stroke 10	stroke 20	stroke 30	stroke 40	stroke 50
6	23	33	43	53	63	15	20	25	30	35	55	65	75	85	95	68,5	78,5	88,5	98,5	108,5

1 - CYLINDERS

Dimensions

Type: **GSB, GSS**
Ø 10 ÷ 16

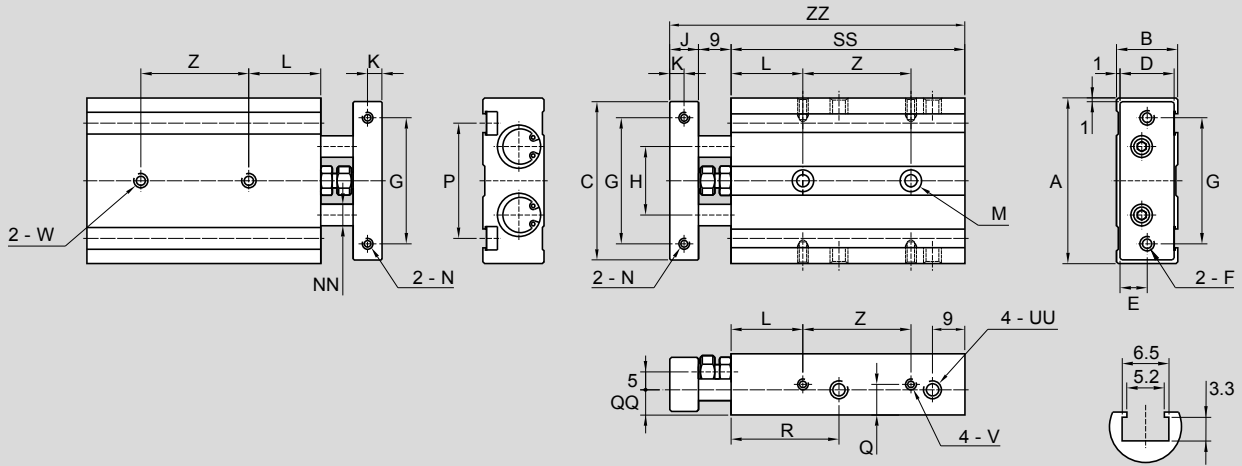

Ø (mm)	A	B	C	D	E	F	G	H	K	J	L	M	N	NN Ø	P	Q	QQ	R	W	V	UU
10	46	17	44	15	7.5	M4	35	19	4	8	20	Ø 3.4 - Ø 6 depth 3.3	M3 depth 5	Ø 6	32	8.5	7	30	M4 depth 8	M3 depth 4.5	M5 depth 4.5
16	58	20	56	18	9	M5	45	24	5	10	30	Ø 4.3 - Ø 8 depth 4.4	M4 depth 6	Ø 8	47	10	10	36	M5 depth 9	M4 depth 5	M5 depth 5.5

Ø (mm)	SS																	
	stroke 10	stroke 15	stroke 20	stroke 25	stroke 30	stroke 35	stroke 40	stroke 45	stroke 50	stroke 60	stroke 70	stroke 75	stroke 80	stroke 90	stroke 100	stroke 125	stroke 150	
10	65	70	75	80	85	90	95	100	105	-	-	-	-	-	-	-	-	-
16	70	75	80	85	90	95	100	105	110	120	130	135	140	150	160	185	210	

Ø (mm)	Z																	
	stroke 10	stroke 15	stroke 20	stroke 25	stroke 30	stroke 35	stroke 40	stroke 45	stroke 50	stroke 60	stroke 70	stroke 75	stroke 80	stroke 90	stroke 100	stroke 125	stroke 150	
10	30	30	30	30	40	40	40	40	40	-	-	-	-	-	-	-	-	
16	25	25	25	25	35	35	35	35	35	45	45	45	45	55	55	80	80	

Ø (mm)	ZZ																	
	stroke 10	stroke 15	stroke 20	stroke 25	stroke 30	stroke 35	stroke 40	stroke 45	stroke 50	stroke 60	stroke 70	stroke 75	stroke 80	stroke 90	stroke 100	stroke 125	stroke 150	
10	82	87	92	97	102	107	112	117	122	-	-	-	-	-	-	-	-	
16	89	94	99	104	109	114	119	124	129	139	149	154	159	169	179	204	229	

Dimensions

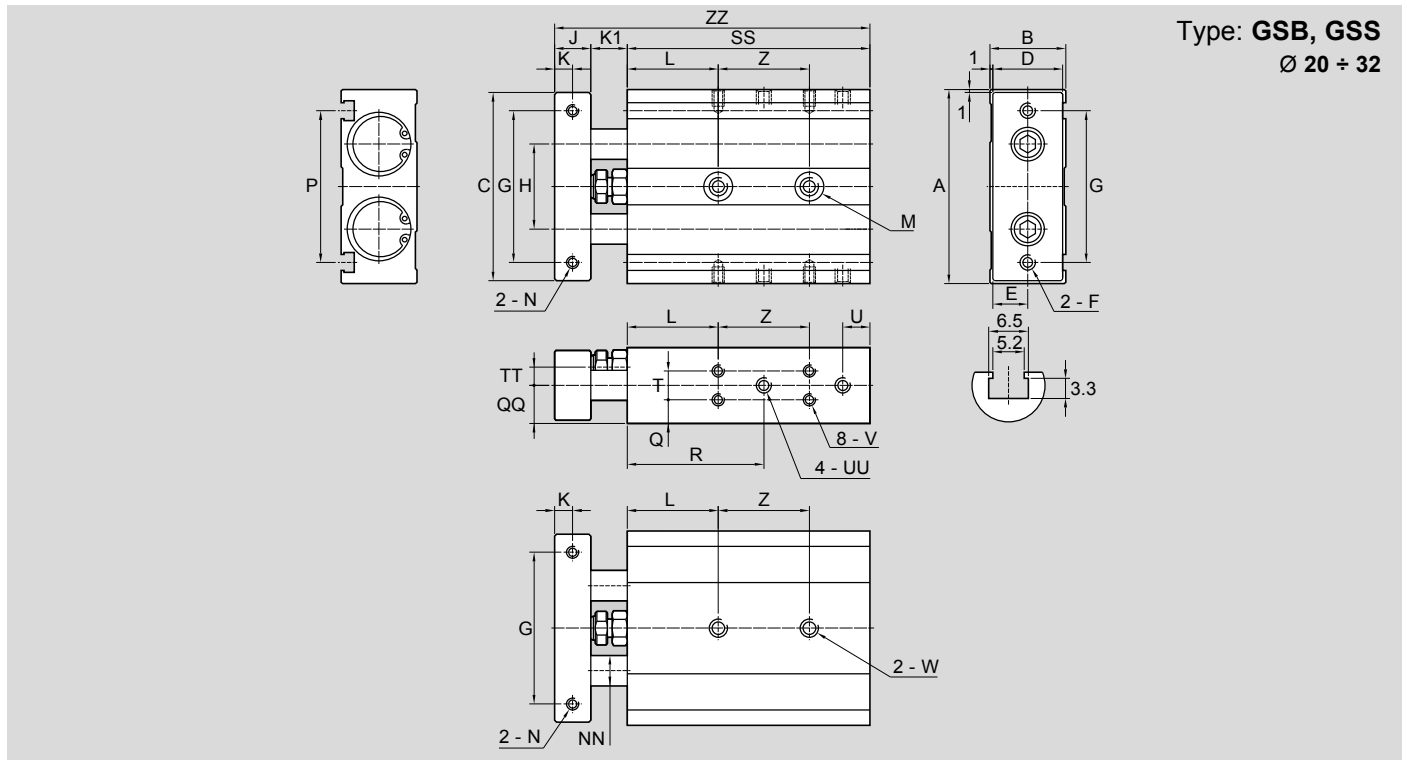

1 - CYLINDERS

Ø (mm)	A	B	C	D	E	F	G	H	K	J	K1	L	M
20	64	25	62	23	11.5	M5	50	28	6	12	12	30	Ø 5.5 - Ø 9.5 depth 5.4
25	80	30	78	28	14	M6	60	35	6	12	12	30	Ø 6.8 - Ø 11 depth 6.3
32	98	38	96	36	18	M6	75	44	8	16	14	30	Ø 6.8 - Ø 11 depth 6.3

Ø (mm)	N	NN Ø	P	Q	QQ	R	T	TT	U	UU	V	W
20	M4 depth 7.5dp	10	50	7.75	12.5	45	9.5	6	9	M5	M4 depth 5.5	M6 depth 10dp
25	M5 depth 7.5dp	12	60	8.5	15	44.5	13	9	10	1/8"	M5 depth 7.5	M8 depth 16dp
32	M5 depth 10dp	16	74	9	19	52.5	20	11	12	1/8"	M5 depth 7.5	M8 depth 16dp

Ø (mm)	SS																	
	stroke 10	stroke 15	stroke 20	stroke 25	stroke 30	stroke 35	stroke 40	stroke 45	stroke 50	stroke 60	stroke 70	stroke 75	stroke 80	stroke 90	stroke 100	stroke 125	stroke 150	
20	80	85	90	95	100	105	110	115	120	130	140	145	150	160	170	195	220	
25	82	87	92	97	102	107	112	117	122	132	142	147	152	162	172	197	222	
32	92	97	102	107	112	117	122	127	132	142	152	157	162	172	182	207	232	

Ø (mm)	Z																	
	stroke 10	stroke 15	stroke 20	stroke 25	stroke 30	stroke 35	stroke 40	stroke 45	stroke 50	stroke 60	stroke 70	stroke 75	stroke 80	stroke 90	stroke 100	stroke 125	stroke 150	
20	30	30	30	30	40	40	40	40	40	60	60	60	60	60	60	85	85	
25	30	30	30	30	40	40	40	40	40	60	60	60	60	60	60	85	85	
32	40	40	40	40	50	50	50	50	50	70	70	70	70	70	70	95	95	

Ø (mm)	ZZ																	
	stroke 10	stroke 15	stroke 20	stroke 25	stroke 30	stroke 35	stroke 40	stroke 45	stroke 50	stroke 60	stroke 70	stroke 75	stroke 80	stroke 90	stroke 100	stroke 125	stroke 150	
20	104	109	114	119	124	129	134	139	144	154	164	169	174	184	194	219	244	
25	106	111	116	121	126	131	136	141	146	156	166	171	176	186	196	221	246	
32	122	127	132	137	142	147	152	157	162	172	182	187	192	202	212	237	262	

Magnetic reed switch T groove ASV..

	For cylinder Ø mm	Code	Item	Cylinder matching
	6 ÷ 32	070946	ASV1C525	GSB GSS
		071863	ASV1C550	
		071864	ASV1C51K	
		071189	ASV1C5M8	
		073639	ASV4D225	
		070246	ASV4D2M8	
		074900	ASV7N225	
		070247	ASV7N2M8	
		070372	ASV7M2M8	
		072918	ASV1H525	

RODLESS

Cylinders



Find out our
key products



Solution for most applications



Easy and intuitive choice



Excellent value for money



Wide availability



Fast delivery



Features and certifications

Series of rodless cylinders, double acting, magnetic, available in bores from Ø 18 to 63. Characterized by the absence of the rod and with a direct power transmission to the yoke, and equipped with newly developed adjustable dampers on both sides. The flow rate can be adjusted from 0 to 100% by turning a pin of an angle of 90°. The new barrel with huge deflection resistance, is provided with grooves for mounting various accessories. Magnetic reed switches can be mounted by a bracket or directly in the grooves, not protruding beyond the profile of the cylinder.

Supplied as standard in compliance with Reach and RoHS directives.



Type S1 Ø 18 ÷ 63 from page 1.26.20



Rodless standard cylinders, available in bores from Ø 18 to 63, double acting, magnetic. Adjustable flow rate, dampers and newly developed tube.

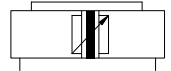

Type S2 Ø 18 ÷ 63 from page 1.26.20



Rodless short standard cylinders, available in bores from Ø 18 to 63, double acting, magnetic. In comparison with type S1, at 0 stroke, has reduced dimension around 42%, so the cylinder is more compact and economic, but suitable for lighter loads.

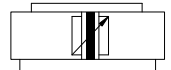

Type S3 Ø 18 ÷ 63 from page 1.26.40



Rodless guided cylinders, available in bores from Ø 18 to 63, double acting, magnetic. The side carriage (which can also be mounted at a later date), is adjustable and allows the cylinder to be used with heavier loads than type S1 and S2. The guide moves by PTFE slides, fixed in the grooves of the barrel.

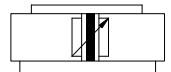

Type S5 Ø 18 ÷ 63 from page 1.26.40



Rodless short guided cylinders, available in bores from Ø 18 to 63, double acting, magnetic. The side carriage (which can also be mounted at a later date), is adjustable and allows the cylinder to be used with heavier loads than type S1 and S2. The guide moves by PTFE slides, fixed in the grooves of the barrel. In comparison with type S3, at 0 stroke, has reduced dimension around 42%, so the cylinder is more compact and economic, but suitable for lighter loads.

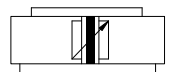

Type S6 Ø 18 ÷ 63 from page 1.26.40



Rodless double guide cylinders, available in bores from Ø 18 to 63, double acting, magnetic. The side carriages (which can also be mounted at a later date), are adjustable and allow the cylinder to be used with heavier loads than type S1, S2, S3 and S5. The guides move by PTFE slides, fixed in the grooves of the barrel.

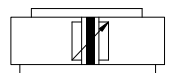

Type S4 Ø 25 ÷ 63 from page 1.26.60



Rodless parallel cylinders, available in bores from Ø 25 to 63, double effect, magnetic. With frontal and lateral yokes and wiper rings. Suitable for high loads and every-direction momentum. Double force and central air connections. If needed it's also possible mount (even at a later date), the lateral guides (special execution).

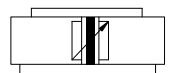

Options		
Description	Symbol	Suffix
Both ports on one head (available from Ø 25, not available for type S4)		U
Carriage with integral brake (available only for type S1)		B

The options, when this is possible, can be combined with each other. For options matching see the table below. Fod code key see page 1.26.4

Options matching				
Series	Bore	Model	Standard options matching	
			U (Ø25+63)	B
S1	Ø 18 ÷ 63	Standard	●	●
		Carriage with integral brake (B)	●	
S2	Ø 18 ÷ 63	Standard	●	-
S3	Ø 18 ÷ 63	Standard	●	-
S4	Ø 25 ÷ 63	Standard	-	-
S5	Ø 18 ÷ 63	Standard	●	-
S6	Ø 18 ÷ 63	Standard	●	-

Key

● allowed matching; - not allowed matching

Code key

Bore	/	Stroke	Type	Options	
32	/	500	S1	U	

Ø 18, 25, 32, 40, 50, 63	10 mm ÷ 9000 mm	S1 Standard Double acting, Magnetic S2 Short Standard Double acting, Magnetic S3 Guided Double acting, Magnetic S4 Parallel Double acting, Magnetic S5 Short Guided Double acting, Magnetic S6 Double Guide Double acting, Magnetic	U from Ø 25 not available for type S4	B Only for type S1
--------------------------	-----------------	--	---	-----------------------

How to order

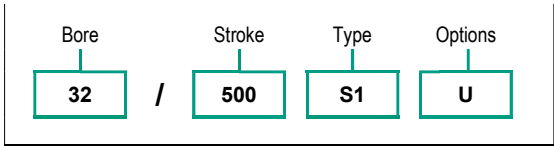

Notes

For further information on options and their matching, see page 1.26.3.

Spare Parts Kit code key

Cylinder bore	/	Spare Parts Set type	/	Length*	/	Cylinder type
50	/	BA	/	5MT	/	S3

Ø 18, 25, 32, 40, 50, 63 mm	SG, PT, BA	1, 5, 10 mt.	S1, S2, S3, S4, S5, S6
-----------------------------	------------	--------------	------------------------

*For Strip Kit only

Seal Kit⁽¹⁾ SG

Number ⁽¹⁾ of components	Description
n. 2	Guide ring
n. 2	Head slide guide
n. 2	Piston seal
n. 2	Cushioning seal
n. 2	Head o-ring

(1) Every cylinder type S4 needs double Seal Kit

Slide Guide Kit⁽²⁾ PT

Number ⁽²⁾ of components	Description
n. 2	PTFE slide guide

(2) Kit for type S6 contains twice components

Strip Kit⁽³⁾ BA

Number ⁽³⁾ of components	Description
n. 1	Internal strip
n. 1	External strip
n. 2	Strip/tube seals

(3) Kit for type S4 contains twice components

Standard materials

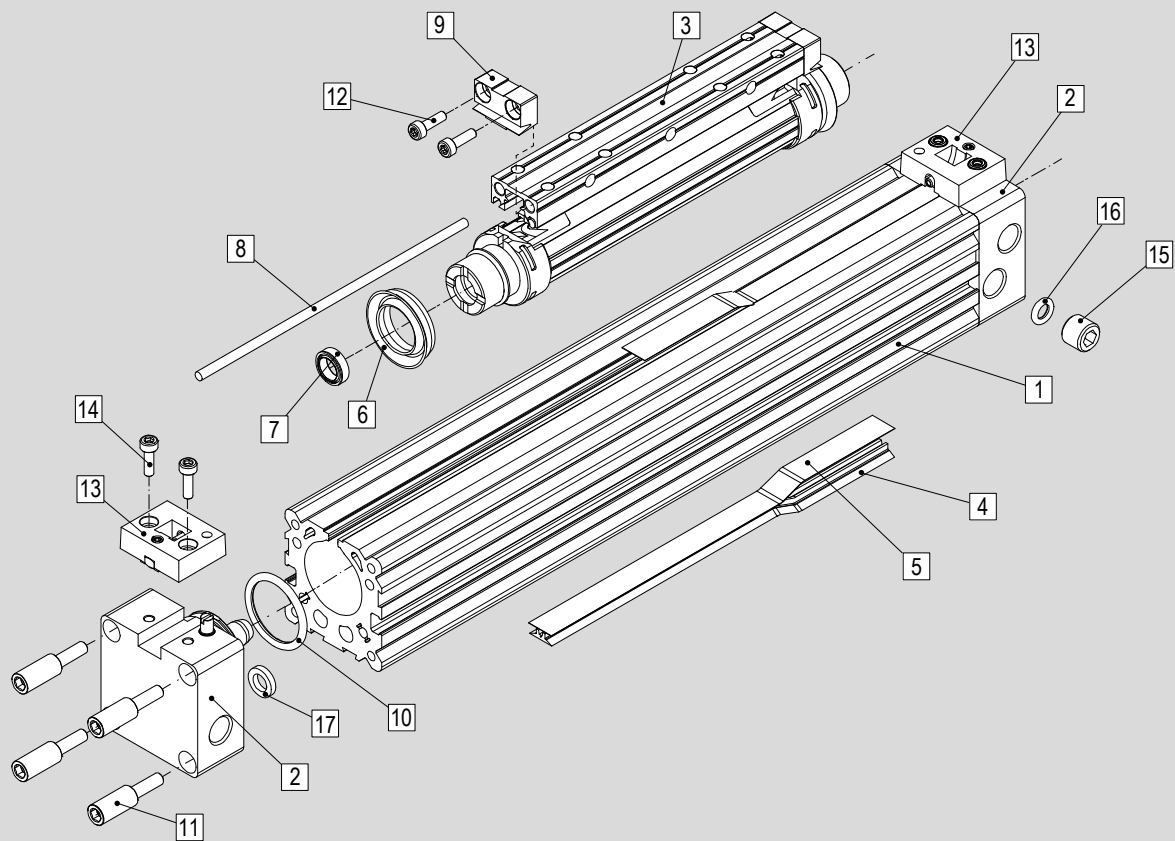

Position	Description	Materials
1	Barrel	Anodised aluminium
2	Head	Anodised aluminium
3	Piston/Yoke block	Aluminium
4	Internal strip	Polyurethane (PU)
5	External strip	Stainless Steel AISI 304
6	Piston seal	Polyurethane (PU)
7	Cushioning seal	PVC
8	Guide ring	PTFE
9	Head slide guide	PVC
10	Head o-ring	Polyurethane (PU)
11	Head special screw	Steel
12	Head slide guide screw	Steel
13	Head cover	PVC
14	Head cover screw	Steel
15	Cushioning screw	Steel
16	O-ring	Polyurethane (PU)
17	Seal	Polyurethane (PU)

Accessories

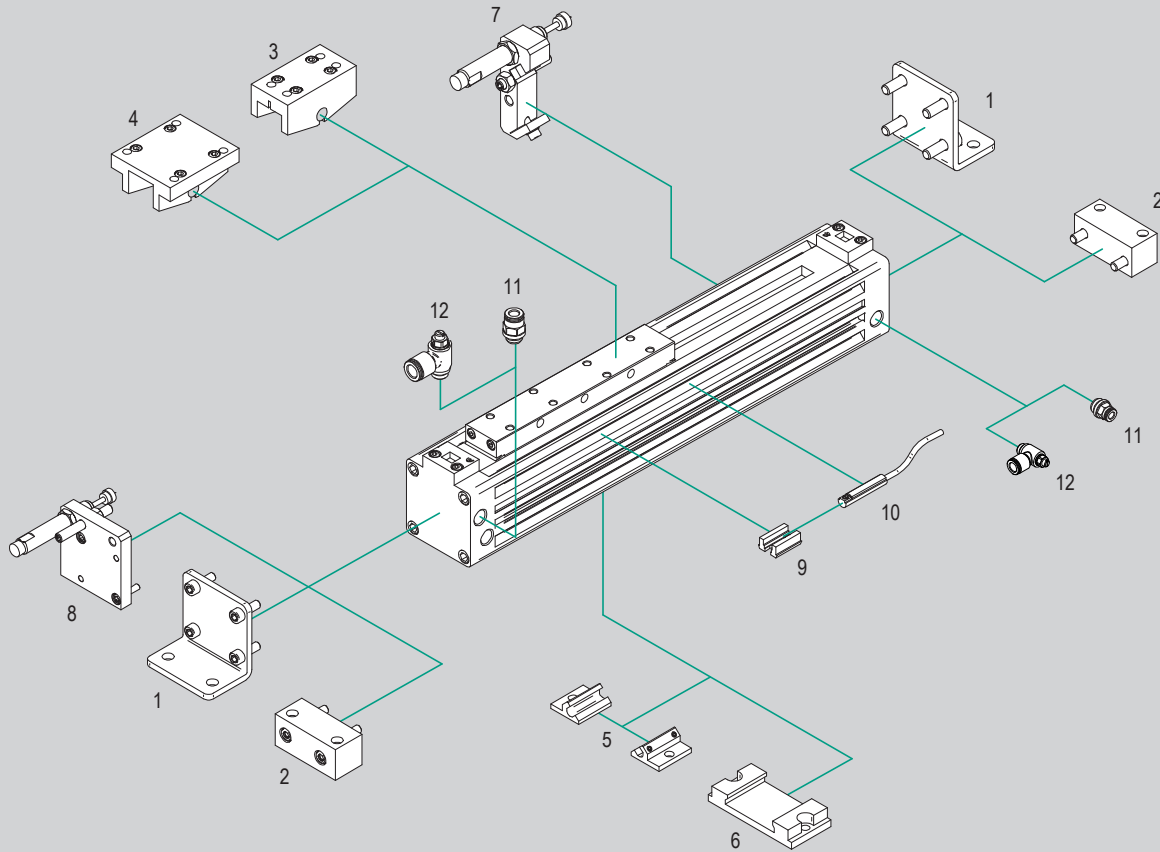

N.	Cylinder bore	Item	Description	Compliance	Matching						Code page	Data sheet page	
					S1	S2	S3	S4	S5	S6			
1	Ø 18 ÷ 63	P..S	Light foot		●	●	●	●	●	●	1.26.90	1.100.253	
2	Ø 18 ÷ 63	PP..S	Heavy foot		●	●	●	●	●	●			1.100.252
3	Ø 18 ÷ 63	CL..S	Light flexible coupling		● ⁽¹⁾	●	-	-	-	-			
4	Ø 18 ÷ 63	C..S	Heavy flexible coupling		● ⁽¹⁾	●	-	-	-	-		1.100.251	
5	Ø 18 ÷ 63	SI..S	Light mid support		● ⁽¹⁾	●	-	●	-	-			1.100.251
6	Ø 18 ÷ 63	SIP..S	Heavy mid support		● ⁽¹⁾	●	-	●	-	-			
7	Ø 18 ÷ 63	SID..S	Mid support for shock absorbers	-	-	-	●	-	●	●	1.100.251		
8	Ø 18 ÷ 63	STD..S	End support for shock absorbers	-	-	-	●	-	●	●		1.100.251	
9	Ø 18	AS109	Bracket for T type magnetic reed switches		●	●	●	-	●	●			1.26.91
10	Ø 18 ÷ 63	ASV..	Magnetic reed switch T groove		●	●	●	●	●	●	1.110.10		
11	Ø 18 ÷ 63	R..	Push-in fittings		●	●	●	●	●	●	4.2.1		
12	Ø 18 ÷ 63	V..C	Flow controls, for cylinders		●	●	●	●	●	●	4.94.1		

Key

● matching accessory; - not matching accessory

(1) Do not matching with option **B** mounted

Main features

18 ÷ 63

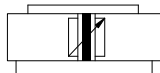

S1

Bores Ø

Standard
Double acting
Magnetic

Type



18 ÷ 63

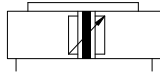

S2

Bores Ø

Short Standard
Double acting
Magnetic

Type



Technical data

Bore Ø mm	18	25	32	40	50	63		
Fluid	Filtered compressed air with or without lubrication. Lubrication, if started, must be continued.							
Pressure range	1,5 ÷ 9 bar							
Temperature range	-10°C ÷ +70°C							
Strokes	10 ÷ 9000 mm							
Ports	M5	G 1/8"		G 1/4"		G 3/8"		
Deceleration stroke	15	18	24	34	40	49		
Theoretical thrust force at 6 bar (N)	140	270	440	680	1060	1680		
Weight (g)	Basic weight	S1	400	800	1300	2200	4300	6600
		S2	100	500	1000	1600	2700	4200
	Additional 10 mm stroke	15	25	34	45	75	95	

Loads and momentum

Type: **S1**

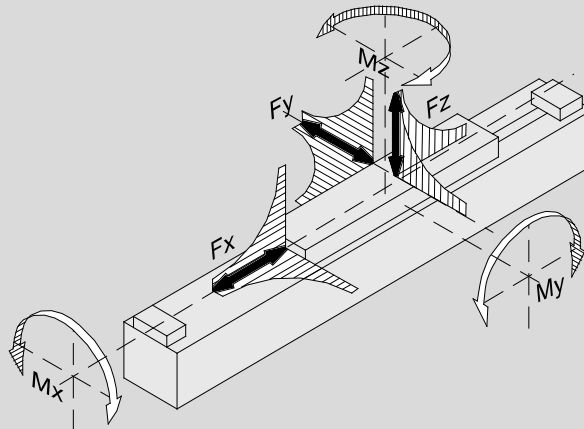

Ø (mm)	Force (Vmax ≤ 0,35 m/s)			F (load in N)			Momentum		
	Fx (N) 6 bar	Fy (N) 6 bar	Fz (N) 6 bar	a 0,75 m/s	a 1 m/s	a 1,5 m/s	Mx (Nm) Fy/Fz	My (Nm) Fx/Fz	Mz (Nm) Fx/Fy
18	140	80	300	80	40	20	1	3	3
25	270	110	480	155	90	40	2	13	13
32	440	165	650	280	155	70	3,5	25	25
40	680	225	800	500	290	125	5,5	40	40
50	1060	325	1060	790	420	195	10	65	65
63	1680	435	1680	1500	850	370	16	100	100

Type: **S2**

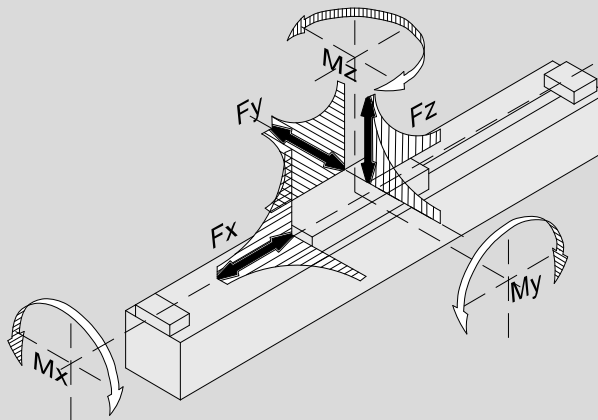

Ø (mm)	Force (Vmax ≤ 0,35 m/s)			F (load in N)			Momentum		
	Fx (N) 6 bar	Fy (N) 6 bar	Fz (N) 6 bar	a 0,75 m/s	a 1 m/s	a 1,5 m/s	Mx (Nm) Fy/Fz	My (Nm) Fx/Fz	Mz (Nm) Fx/Fy
18	140	40	140	40	25	10	0,4	1,7	1,7
25	270	55	230	90	50	25	0,7	2,7	2,7
32	440	70	320	200	110	45	1	5	5
40	680	100	400	420	240	110	2	8,5	8,5
50	1060	140	480	750	440	190	3,5	13	13
63	1680	180	590	1500	850	380	5	18	18

All data regarding the forces, refer to a speed of $V \leq 0,35$ m/s.

Maintaining the indicated values will allow to optimize lifetime, noise and efficiency. Higher speeds greatly reduce allowable forces. If operating conditions are outside the allowable limits (see table above), the energy of the moving mass must be absorbed by appropriate devices (hydraulic decelerators, stops, and similar), mounted as close as possible to the mass center of gravity.

Maximum allowable deflections

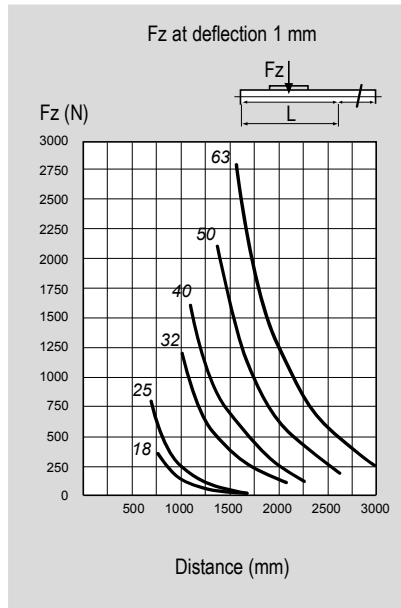
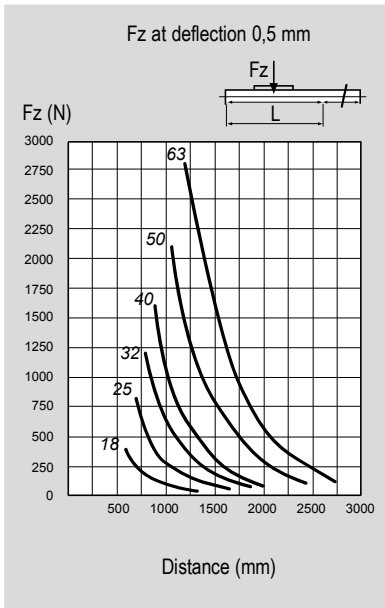

With long strokes cylinders or heavy loads, you should pay attention to the tube deflection. One or more mid supports can be used according to the admissible deflection.

Example:
When applying a force $F_z = 500$ N to a cylinder 25 mm which could not deflect over 0,5 mm cannot be longer than 750 mm according to the diagram.
Should you exceed 750 mm use one or more mid supports (for mid support see page 1.26.90).

Standard dimensions

Type: S1

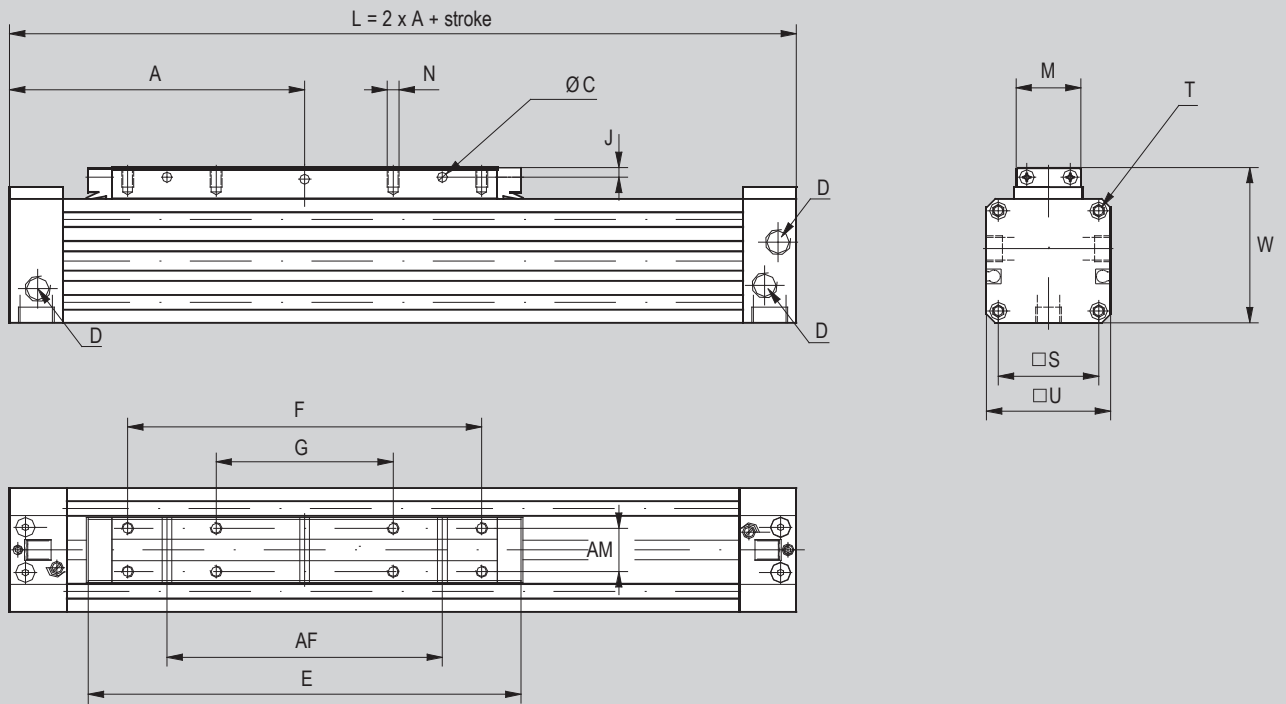

1 - CYLINDERS

Ø (mm)	A	AF	AM	D	E	F	G	J	M	N	ØC	□S	T	□U	W
18	80	50	10	M5x6	103	75	-	3	15.5	M3x6	3.5	23.5	M3x7	30	39
25	100	70	13	G1/8x8	131	100	50	3.5	20	M4x7	4.5	33	M4x9	42	53
32	120	100	16	G1/8x8	171	140	70	4.5	25	M5x9	5.5	41	M5x10	52	65
40	150	140	22	G1/4x12	220	180	90	5	33	M6x10	7	51	M6x12	63	79
50	180	180	29	G1/4x12	280	220	110	6.5	42	M8x12.5	7	63	M8x12	78	96
63	215	230	40	G3/8x12	333	280	140	8	54	M8 x 15	9	78	M8x12	93	113.5

Standard dimensions

Type: S2

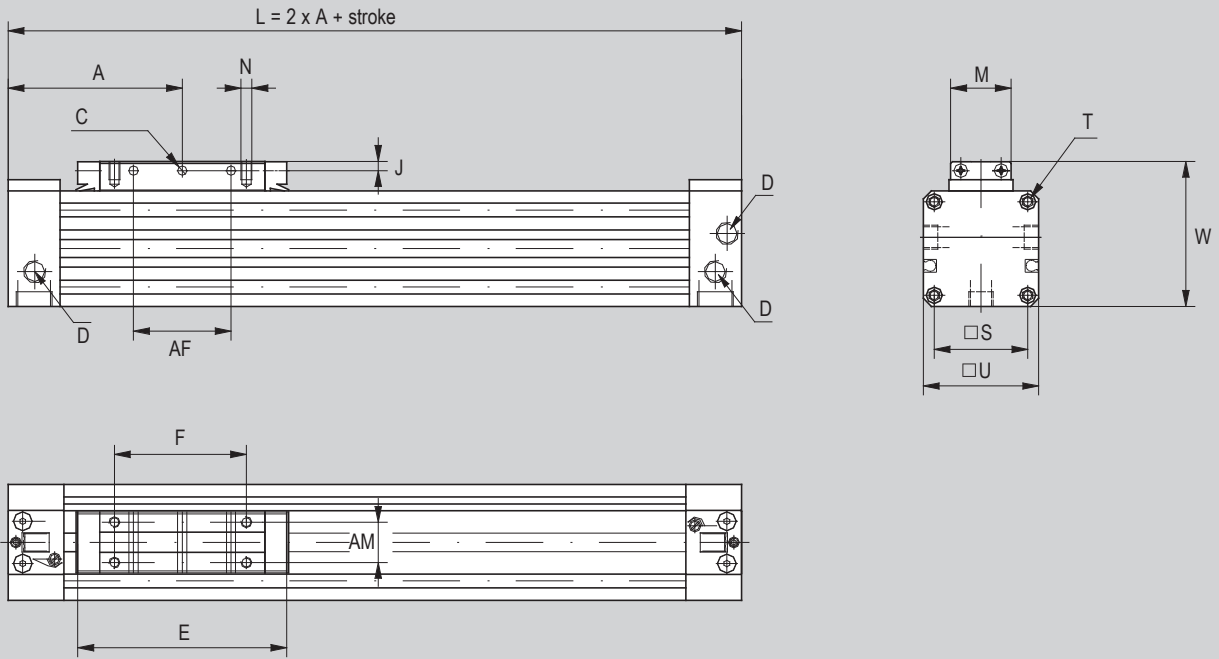

Ø (mm)	A	AF	AM	D	E	F	J	M	N	ØC	ØS	T	ØU	W
18	57.5	15	10	M5x6	58	30	3	15.5	M3x6	3.5	23.5	M3x7	30	39
25	67.5	19	13	G1/8x8	66	35	3.5	20	M4x7	4.5	33	M4x9	42	53
32	77.5	35	16	G1/8x8	86	55	4.5	25	M5x9	5.5	41	M5x10	52	65
40	95	50	22	G1/4x12	110	70	5	33	M6x10	7	51	M6x12	63	79
50	105	46	29	G1/4x12	130	70	6.5	42	M8x12	7	63	M8x12	78	96
63	125	70	40	G3/8x12.5	153	100	8	54	M8x15	9	78	M8x12	93	113.5

Dimensions with options

Type: ...B
only for type S1

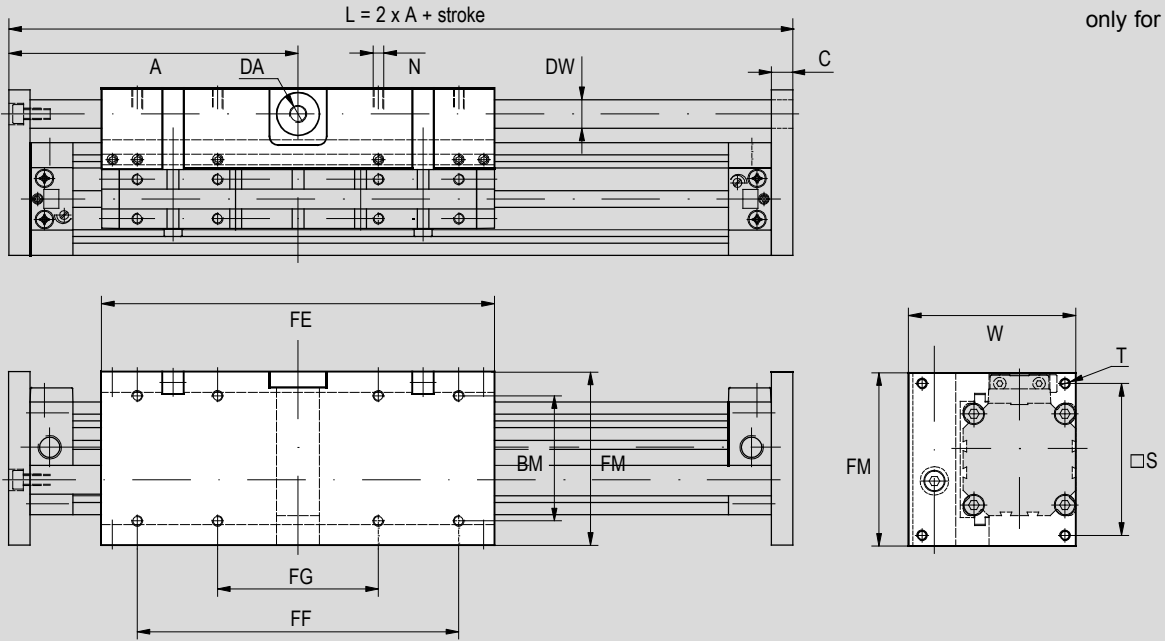

Type: ...U
Ø 25 ÷ 63

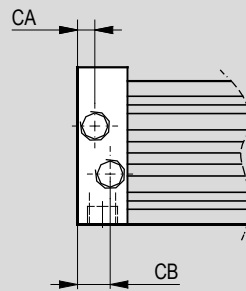

Ø (mm)	A	BM	C	DA	DW	FE	FF	FG	FM	W	N	S	T	CA	CB
18	86	35	6	M5	Ø 6	103	75	-	50	48	M4x7,5	42	M3	-	-
25	110	45	10	M5	Ø 12	131	100	50	66	67	M4x8	54	M4	7	13
32	130	55	10	M5	Ø 12	171	140	70	80	79	M5x10	68	M5	7	13
40	162	70	12	1/8"	Ø 16	220	180	90	97	93,5	M6x12	80	M6	11	14,5
50	195	85	15	1/8"	Ø 20	280	220	110	116	115,5	M8x16	100	M8	12	14
63	230	105	15	1/8"	Ø 20	333	280	140	136	139	M8x16	120	M8	12,5	15,5

Main features

18 ÷ 63

Bores Ø

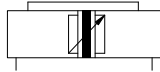

Guided
Double acting
Magnetic

S3

Type



18 ÷ 63

Bores Ø

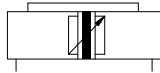

Short Guided
Double acting
Magnetic

S5

Type



18 ÷ 63

Bores Ø

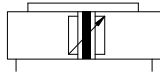

Double Guide
Double acting
Magnetic

S6

Type



Technical data

Bore Ø mm		18	25	32	40	50	63	
Fluid		Filtered compressed air with or without lubrication. Lubrication, if started, must be continued.						
Pressure range		2 ÷ 8 bar						
Temperature range		-20°C ÷ +80°C						
Strokes		10 ÷ 9000 mm						
Ports		M5	G 1/8"		G 1/4"		G 3/8"	
Deceleration stroke		15	18	24	34	40	49	
Theoretical thrust force at 6 bar (N)		140	270	440	680	1060	1680	
Weight (g)	Basic weight	S3	500	1100	1800	3200	5900	8400
		S5	300	700	1300	2100	3400	5500
		S6	600	1300	2400	4200	7500	10000
Additional 10 mm stroke		15	25	34	45	75	95	

Loads and momentum

1 - CYLINDERS

Type: **S3**

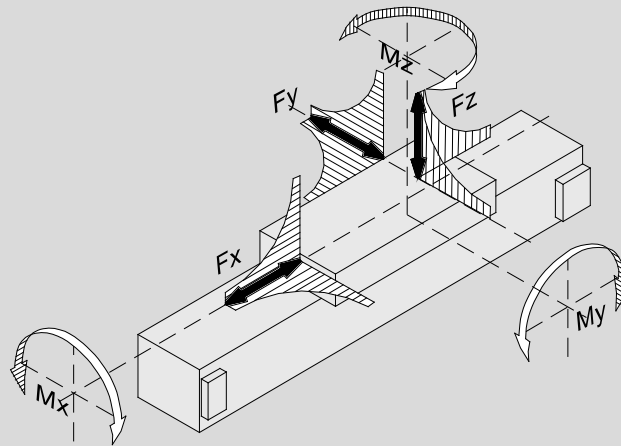

Ø (mm)	Force (Vmax ≤ 0,35 m/s)			F (load in N)			Momentum		
	Fx (N) 6 bar	Fy (N) 6 bar	Fz (N) 6 bar	a 0,75 m/s	a 1 m/s	a 1,5 m/s	Mx (Nm) Fy/Fz	My (Nm) Fx/Fz	Mz (Nm) Fx/Fy
18	140	370	370	100	58	26	3,5	6	6
25	270	800	800	280	160	65	10	20	20
32	440	1200	1200	510	300	140	25	45	45
40	680	1600	1600	1000	550	250	40	75	75
50	1060	2100	2100	1500	850	380	80	150	150
63	1680	2800	2800	2500	1400	610	110	250	250

Type: **S5**

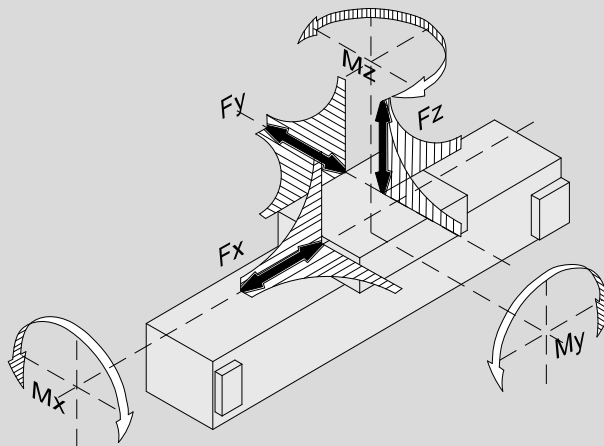

Ø (mm)	Force (Vmax ≤ 0,35 m/s)			F (load in N)			Momentum		
	Fx (N) 6 bar	Fy (N) 6 bar	Fz (N) 6 bar	a 0,75 m/s	a 1 m/s	a 1,5 m/s	Mx (Nm) Fy/Fz	My (Nm) Fx/Fz	Mz (Nm) Fx/Fy
18	140	150	150	50	30	12	1,8	1,8	1,8
25	270	250	250	100	60	30	4	4	4
32	440	450	450	250	135	65	10	10	10
40	680	600	600	480	280	140	16	16	16
50	1060	900	900	800	480	220	30	30	30
63	1680	1100	1100	1500	950	400	45	45	45

Loads and momentum

Type: **S6**

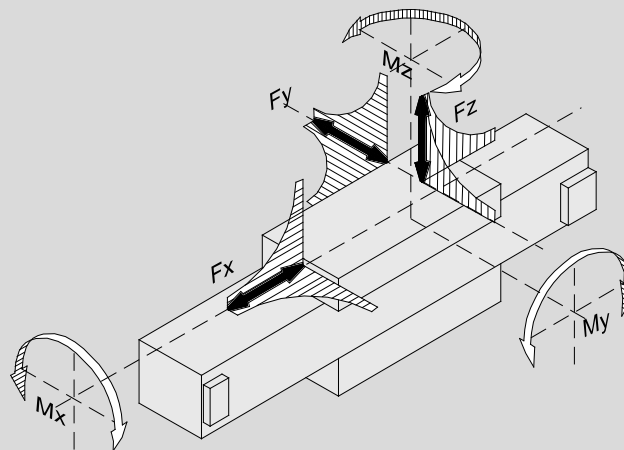

1 - CYLINDERS

Ø (mm)	Force (Vmax ≤ 0,35 m/s)			F (load in N)			Momentum		
	Fx (N) 6 bar	Fy (N) 6 bar	Fz (N) 6 bar	a 0,75 m/s	a 1 m/s	a 1,5 m/s	Mx (Nm) Fy/Fz	My (Nm) Fx/Fz	Mz (Nm) Fx/Fy
18	140	550	550	150	80	20	5,2	9	9
25	270	1200	1200	420	210	80	15	30	30
32	440	1800	1800	750	400	170	37	67	67
40	680	2400	2400	1500	750	300	60	110	110
50	1060	3200	3200	2200	1150	460	120	220	220
63	1680	4200	4200	3700	1900	740	170	370	370

All data regarding the forces, refer to a speed of $V \leq 0,35$ m/s.
Maintaining the indicated values will allow to optimize lifetime, noise and efficiency. Higher speeds greatly reduce allowable forces. If operating conditions are outside the allowable limits (see table above), the energy of the moving mass must be absorbed by appropriate devices (hydraulic decelerators, stops, and similar), mounted as close as possible to the mass center of gravity.

Maximum allowable deflections

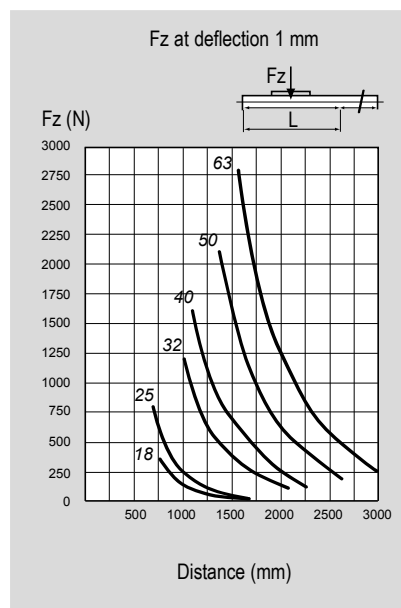
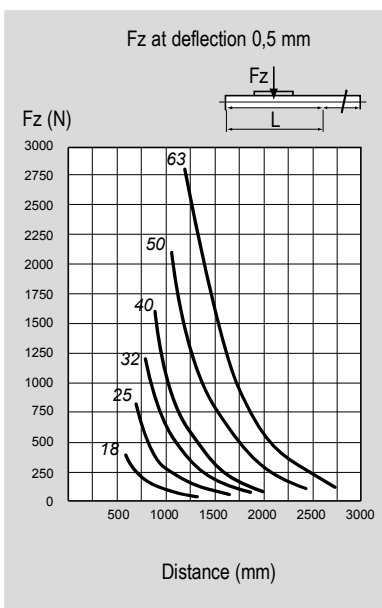

With long strokes cylinders or heavy loads, you should pay attention to the tube deflection.
One or more mid supports can be used according to the admissible deflection.

Example:
When applying a force $Fz = 500$ N to a cylinder 25 mm which could not deflect over 0,5 mm cannot be longer than 750 mm according to the diagram.
Should you exceed 750 mm use one or more mid supports (for mid support see page 1.26.90).

Standard dimensions

Type: S3

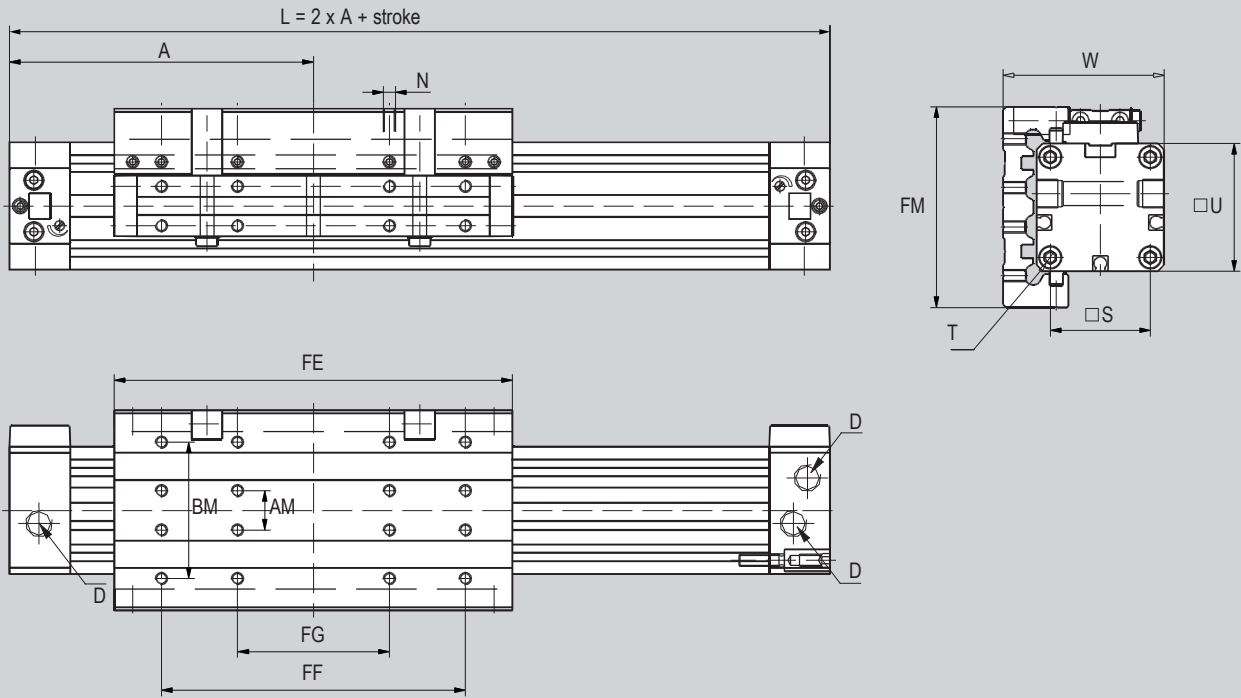

∅ (mm)	A	AM	BM	D	FE	FF	FG	FM	W	N	□S	T	□U
18	80	10	35	M5x6	103	75	-	50	39	M4x7,5	23,5	M3x7	30
25	100	13	45	G1/8x8	131	100	50	66	53	M4x8	33	M4x9	42
32	120	16	55	G1/8x8	171	140	70	80	65	M5x10	41	M5x10	52
40	150	22	70	G1/4x12	220	180	90	97	79	M6x12	51	M6x12	63
50	180	29	85	G1/4x12	280	220	110	116	96	M8x16	63	M8x12	78
63	215	40	105	G3/8x12	333	280	140	136	113,5	M8x16	78	M8x12	93

Standard dimensions

Type: **S5**

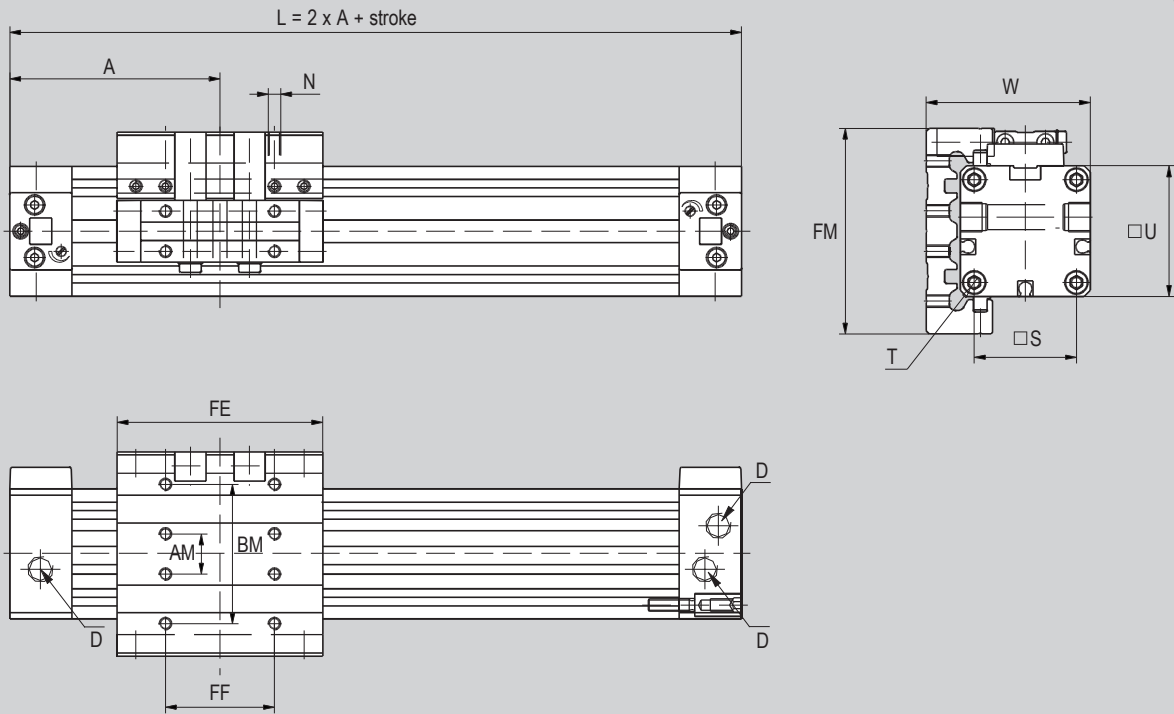

\varnothing (mm)	A	AM	BM	D	FE	FF	FM	W	N	$\square S$	T	$\square U$
18	57.5	10	35	M5x6	58	30	50	39	M4x7.5	23.5	M3x7	30
25	67.5	13	45	G1/8x8	66	35	66	53	M4x8	33	M4x9	42
32	77.5	16	55	G1/8x8	86	55	80	65	M5x10	41	M5x10	52
40	95	22	70	G1/4x12	110	70	97	79	M6x12	51	M6x12	63
50	105	29	85	G1/4x12	130	70	116	96	M8x16	63	M8x12	78
63	125	40	105	G3/8x12	153	100	136	113.5	M8x16	78	M8x12	93

Standard dimensions

Type: S6

1 - CYLINDERS

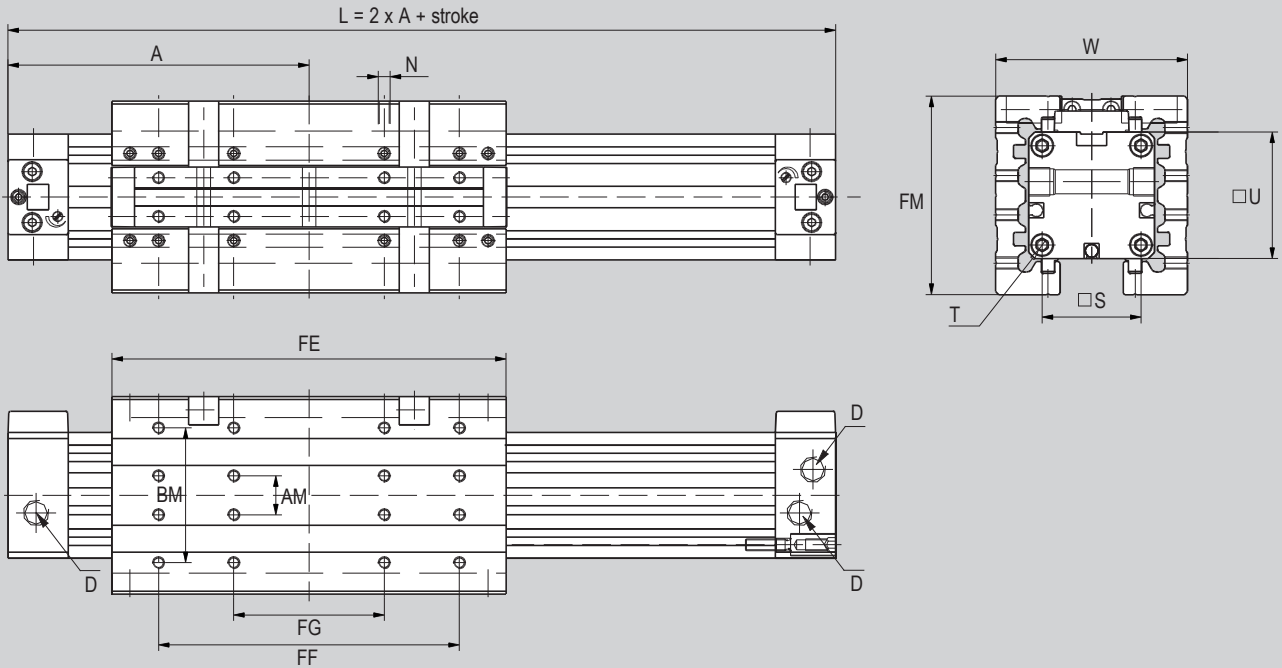

\varnothing (mm)	A	AM	BM	D	FE	FF	FG	FM	W	N	$\square S$	T	$\square U$
18	80	10	35	M5x6	103	75	-	50	48	M4x7.5	23.5	M3x7	30
25	100	13	45	G1/8x8	131	100	50	66	64	M4x8	33	M4x9	42
32	120	16	55	G1/8x8	171	140	70	80	78	M5x10	41	M5x10	52
40	150	22	70	G1/4x12	220	180	90	97	95	M6x12	51	M6x12	63
50	180	29	85	G1/4x12	280	220	110	116	114	M8x16	63	M8x12	78
63	215	40	105	G3/8x12	333	280	140	136	134	M8x16	78	M8x12	93

Dimensions with options

Type: ...U
Ø 25 ÷ 63

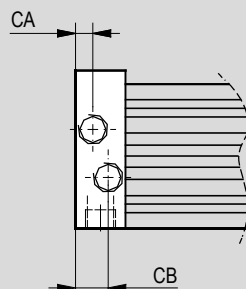

Ø (mm)	CA	CB	
25	7	13	
32	7	13	
40	11	14.5	
50	12	14	
63	12,5	15,5	

Rodless Cylinders

Series S4



Main features

25 ÷ 63

Bores Ø

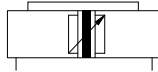

Parallel
Double acting
Magnetic

S4

Type



Technical data

Bore Ø mm	25	32	40	50	63	
Fluid	Filtered compressed air with or without lubrication. Lubrication, if started, must be continued.					
Pressure range	2 ÷ 8 bar					
Temperature range	-20°C ÷ +80°C					
Strokes	10 ÷ 9000 mm					
Ports	G 1/4"		G 3/8"		G 1/2"	
Deceleration stroke	18	24	34	40	49	
Theoretical thrust force at 6 bar (N)	540	880	1360	2120	3360	
Weight (g)	Basic weight	1900	3300	5800	11700	17000
	Additional 10 mm stroke	50	68	98	150	190

Loads and momentum

Type: **S4**

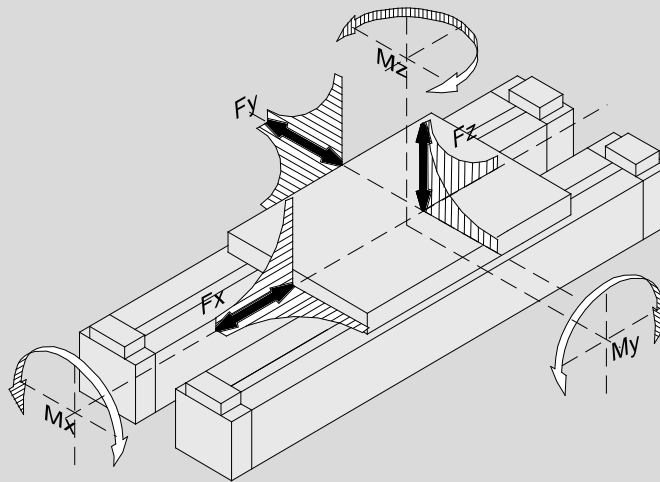

Ø (mm)	Force (Vmax ≤ 0,35 m/s)			F (load in N)			Momentum		
	Fx (N) 6 bar	Fy (N) 6 bar	Fz (N) 6 bar	a 0,75 m/s	a 1 m/s	a 1,5 m/s	Mx (Nm) Fy/Fz	My (Nm) Fx/Fz	Mz (Nm) Fx/Fy
25	540	240	900	300	175	75	16	27	27
32	880	360	1220	540	300	130	29	52	52
40	1360	540	1750	1090	620	280	55	88	88
50	2120	750	2500	1760	1000	450	90	155	155
63	3360	1000	3300	2900	1660	720	148	260	260

All data regarding the forces, refer to a speed of $V \leq 0,35$ m/s.

Maintaining the indicated values will allow to optimize lifetime, noise and efficiency. Higher speeds greatly reduce allowable forces. If operating conditions are outside the allowable limits (see table above), the energy of the moving mass must be absorbed by appropriate devices (hydraulic decelerators, stops, and similar), mounted as close as possible to the mass center of gravity.

Maximum allowable deflections

Fz at deflection 0,5 mm

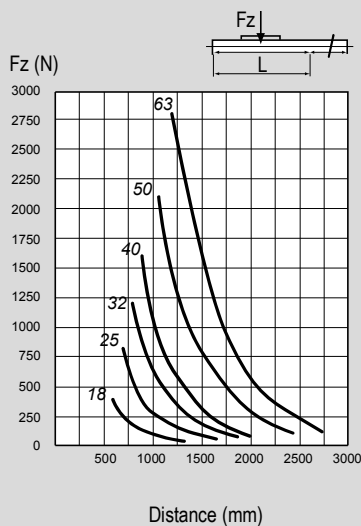

Fz at deflection 1 mm

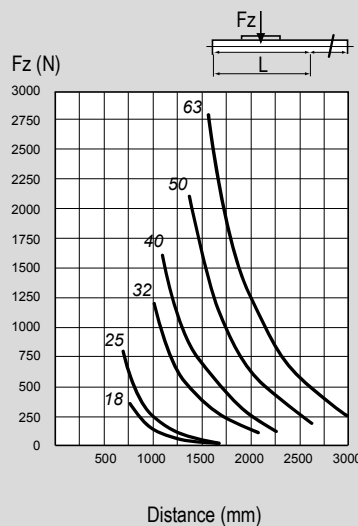

With long strokes cylinders or heavy loads, you should pay attention to the tube deflection.

One or more mid supports can be used according to the admissible deflection.

Example:

When applying a force $Fz = 500$ N to a cylinder 25 mm which could not deflect over 0,5 mm cannot be longer than 750 mm according to the diagram.

Should you exceed 750 mm use one or more mid supports (for mid support see page 1.26.90).

Standard dimensions

Type: **S4**

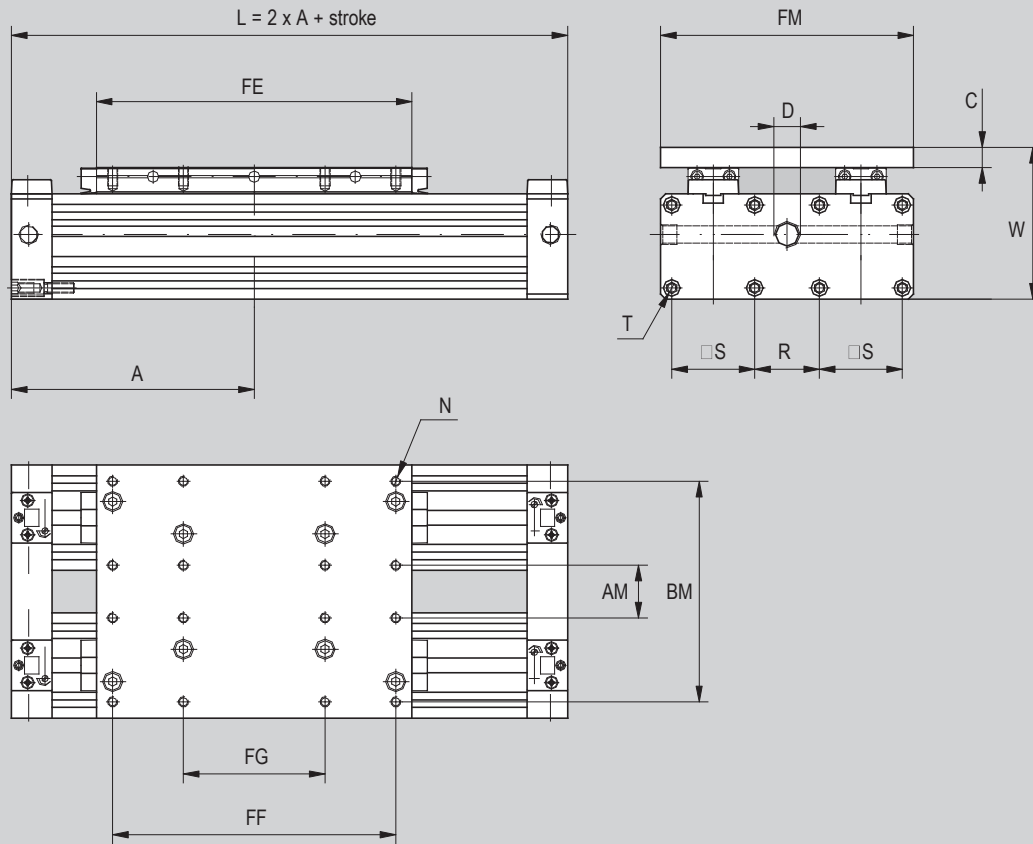

Ø (mm)	A	C	D	FE	FF	FG	AM	BM	FM	N	R	S	T	W
25	100	8	G1/4x12	116	100	50	21	79	92	M4	17	33	M4x9	61
32	120	10	G1/4x12	156	140	70	26	109	125	M5	31	41	M5x10	75
40	150	12	G3/8x12	200	180	90	35	139	159	M6	45	51	M6x12	91
50	180	15	G3/8x12	260	220	110	44	164	184	M8	43	63	M8x12	111
63	215	15	G1/2x13	313	280	140	55	195	218	M8	47	78	M8x12	128.5

Light foot* P..S

	For cylinder Ø mm	Code	Item	Cylinder matching
	18	559010	P18S	S1 S2 S3 S4 S5 S6
	25	559011	P25S	
	32	559012	P32S	
	40	559013	P40S	
	50	559014	P50S	
	63	559015	P63S	

*Kit composed by 2 feet

Heavy foot* PP..S

	For cylinder Ø mm	Code	Item	Cylinder matching
	18	559096	PP18S	S1 S2 S3 S4 S5 S6
	25	559097	PP25S	
	32	559098	PP32S	
	40	559099	PP40S	
	50	559100	PP50S	
	63	559101	PP63S	

*Kit composed by 2 feet

Light mid support* SI..S

	For cylinder Ø mm	Code	Item	Cylinder matching
	18	559020	SI18S	S1** S2 S4
	25	559021	SI25S	
	32	559022	SI32S	
	40	559023	SI40S	
	50	559024	SI50S	
	63	559025	SI63S	

*Kit composed by 2 supports

Do not matching with option **B mounted

Heavy mid support* SIP..S

	For cylinder Ø mm	Code	Item	Cylinder matching
	18	559102	SIP18S	S1** S2 S4
	25	559103	SIP25S	
	32	559104	SIP32S	
	40	559105	SIP40S	
	50	559106	SIP50S	
	63	559107	SIP63S	

*Kit composed by 2 supports

Do not matching with option **B mounted

Light flexible coupling CL..S

	For cylinder Ø mm	Code	Item	Cylinder matching
	18	559038	CL18S	S1** S2
	25	559037	CL25S	
	32	559032	CL32S	
	40	559033	CL40S	
	50	559034	CL50S	
	63	559035	CL63S	

Do not matching with option **B mounted

Heavy flexible coupling C..S

	For cylinder Ø mm	Code	Item	Cylinder matching
	18	559001	C18S	S1** S2
	25	559002	C25S	
	32	559003	C32S	
	40	559004	C40S	
	50	559005	C50S	
	63	559006	C63S	

Do not matching with option **B mounted

Mid support for shock absorbers* SID..S

	For cylinder Ø mm	Code	Item	Cylinder matching
	18	559060	SID18S	S3 S5 S6
	25	559061	SID25S	
	32	559062	SID32S	
	40	559063	SID40S	
	50	559064	SID50S	
	63	559065	SID63S	

*Shock absorber to be ordered separately, see page 1.105.1

End support for shock absorbers* STD..S

	For cylinder Ø mm	Code	Item	Cylinder matching
	18	559070	STD18S	S3 S5 S6
	25	559071	STD25S	
	32	559072	STD32S	
	40	559073	STD40S	
	50	559074	STD50S	
	63	559075	STD63S	



*Shock absorber to be ordered separately, see page 1.105.1

Bracket AS109 (for magnetic reed switches T groove)

	For cylinder Ø mm	Code	Item	Cylinder matching*
	18	072916	AS109	S..

*Required only for Ø 18

Magnetic reed switch T groove ASV..

	For cylinder Ø mm	Code	Item	Cylinder matching*
	18 ÷ 63	070946 	ASV1C525	S1 S2 S3 S4 S5 S6
		071863	ASV1C550	
		071864	ASV1C51K	
		071189	ASV1C5M8	
		073639	ASV4D225	
		070246 	ASV4D2M8	
		074900	ASV7N225	
		070247	ASV7N2M8	
		070372	ASV7M2M8	
		072918	ASV1H525	

*For Ø 18 use the bracket type AS109, for Ø 25 ÷ 63 use grooves.

ROTARY

Cylinders



Find out our
key products



Solution for most applications



Easy and intuitive choice



Excellent value for money



Wide availability



Fast delivery



Features and certifications

Series of rotary cylinders with rack and pinion, available in bores \varnothing 40, 63 and 80, double acting, magnetic, with 90° or 180° rotation angle. Equipped with adjustable cushionings, and with possibility to apply magnetic reed switches. Available in three configurations: male pinion, double male pinion or female pinion. Supplied as standard in compliance with Reach and RoHS directives.



Type CRTH \varnothing 40 - 63 - 80 from page 1.40.20



Rotary cylinders with male pinion, available in bores \varnothing 40, 63 and 80, double acting, magnetic, with 90° or 180° rotation angle. Equipped with adjustable cushionings, and with possibility to apply magnetic reed switches.

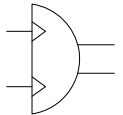

Type CRTHD \varnothing 40 - 63 - 80 from page 1.40.20



Rotary cylinders with double male pinion, available in bores \varnothing 40, 63 and 80, double acting, magnetic, with 90° or 180° rotation angle. Equipped with adjustable cushionings, and with possibility to apply magnetic reed switches.

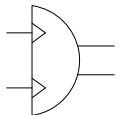

Type CRTF \varnothing 40 - 63 - 80 from page 1.40.20



Rotary cylinders with female pinion, available in bores \varnothing 40, 63 and 80, double acting, magnetic, with 90° or 180° rotation angle. Equipped with adjustable cushionings, and with possibility to apply magnetic reed switches.

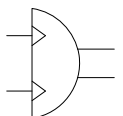

Options

Description	Symbol	Suffix
Special versions on request		/S

Code key

Bore	/	Angle of rotation	Type	/	Special version
63	/	90°	CRTH	/	

Ø 40, 63, 80

90° - 180°

CRTH
Double acting, magnetic
Male pinion

CRTHD
Double acting, magnetic
Double male pinion

CRTF
Double acting, magnetic
Female pinion

S

How to order

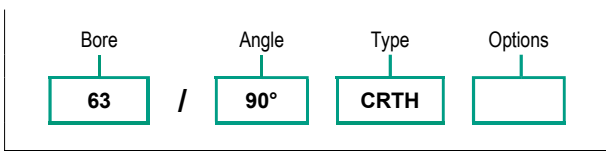

Notes

For further information on options see the table above.

Standard materials

1 - CYLINDERS

Type: CRTH, CRTHD

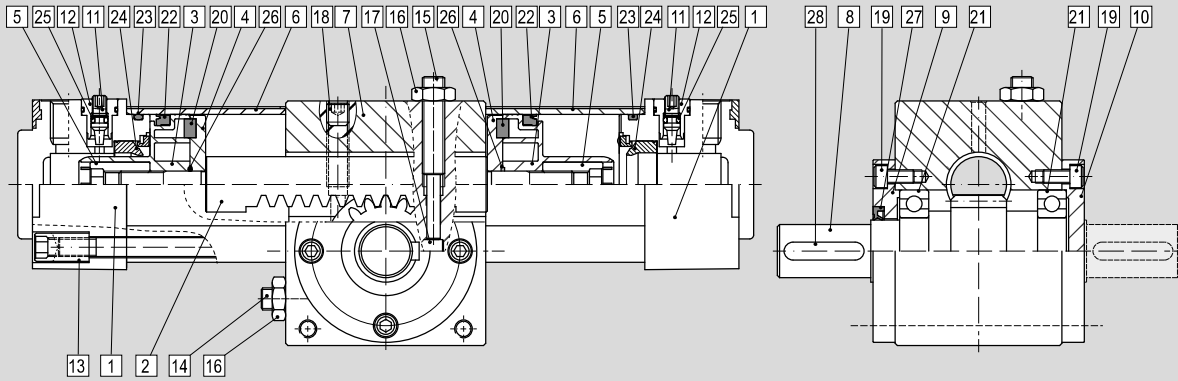

Type: CRTF

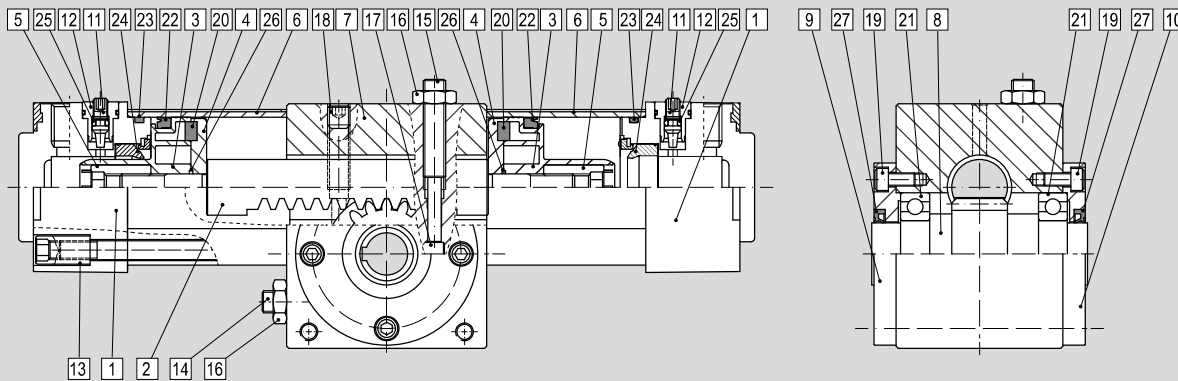

Position	Description	Materials
1	End cover	Anodised aluminium
2	Rack	Carbon steel
3	Piston	Acetalic resin (POM)
4	Magnet holder	Anodised aluminium
5	Piston nut	Carbon steel
6	Cylinder barrel	Anodised aluminium
7	Body	Anodised aluminium
8	Pinion	Carbon steel
9	End cover	Anodised aluminium
10	End cover	Anodised aluminium
11	Cushion needle	Stainless Steel
12	Cushion screw guide	Nickel-plated brass
13	Tie bolt	Galvanized carbon steel
14	Adjusting screw	Carbon steel blackening
15	Adjusting screw	Carbon steel blackening
16	Lock nut	Carbon steel
17	Stopper pin	Carbon steel
18	Adjusting screw	Carbon steel blackening
19	Screw	Nickel-plated carbon steel
20	Magnet	Magnetic material
21	Ball bearing	Carbon steel
22	Piston packing	NBR
23	Tube-head gasket	NBR
24	Cushioning seal	NBR
25	O-ring	NBR
26	Piston o-ring	NBR
27	Rod packing	NBR
28	Key	Carbon steel

Accessories

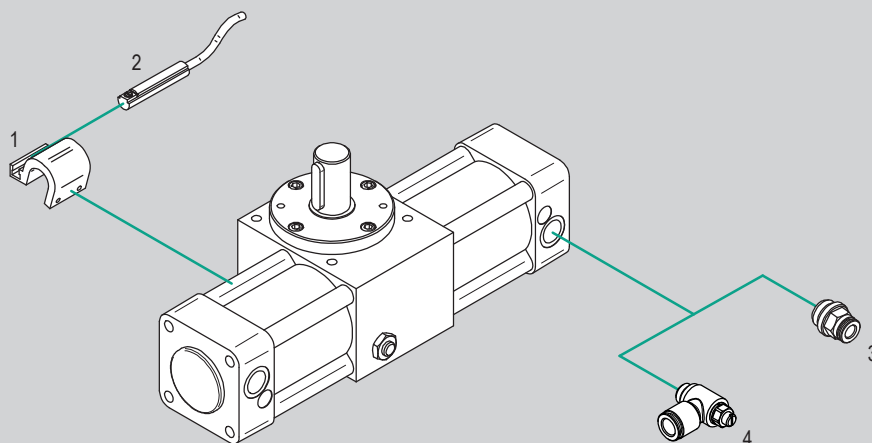

N.	Cylinder bore	Item	Description	Compliance	Matching			Code page	Data sheet page
					CRTH	CRTHD	CRTF		
1	Ø 40 - 63 - 80	AS..	Bracket for T type magnetic reed switches	-	●	●	●	1.40.90	1.120.3
2		ASV..	Magnetic reed switch T groove		●	●	●		1.110.10
3	Ø 40 - 63 - 80	R..	Push-in fittings		●	●	●	4.2.1	
4	Ø 40 - 63 - 80	V..C	Flow controls, for cylinders		●	●	●	4.94.1	

Key

● allowed matching; - not allowed matching

Rotary Cylinders

Series CRTH - CRTHD - CRTF



1 - CYLINDERS

Main features

40 - 63 - 80

90°-180°



CRTH

Bores Ø

Angle of rotation

Double acting
Magnetic
Male pinion

Type



40 - 63 - 80

90°-180°



CRTHD

Bores Ø

Angle of rotation

Double acting
Magnetic
Double Male
Pinion

Type



40 - 63 - 80

90°-180°



CRTF

Bores Ø

Angle of rotation

Double acting
Magnetic
Female Pinion

Type



Technical data

Bore Ø mm	40		63		80		
Fluid	Filtered compressed air with or without lubrication. Lubrication, if started, must be continued.						
Angle of rotation	90°	180°	90°	180°	90°	180°	
Adjustable angle	±5°						
Pinion diameter	16		24		28		
Pressure range	1,3 ÷ 7 bar						
Maximum allowable axial thrust (Kg)	10		12		20		
Cushion angle	74°		75°		80°		
Temperature range	-10°C ÷ +60°C						
Weight (g)	CRTH	3000	3100	5400	5800	9750	10300
	CRTHD	3050	3150	5550	5950	9990	10540
	CRTF	2840	2940	5070	5470	9990	9740

Rotating direction and adjustable angle

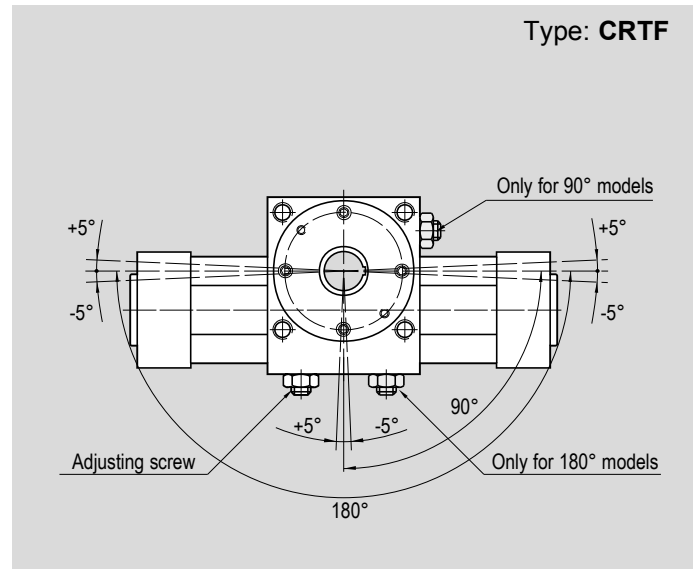
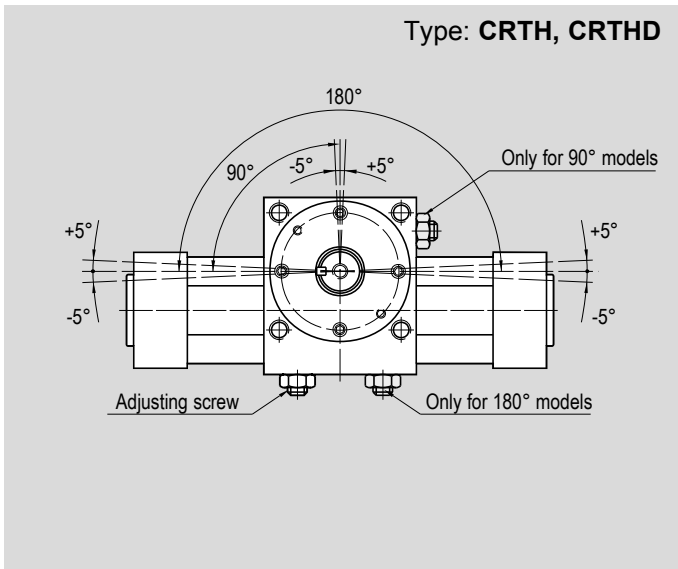

1 - CYLINDERS

Output torque table

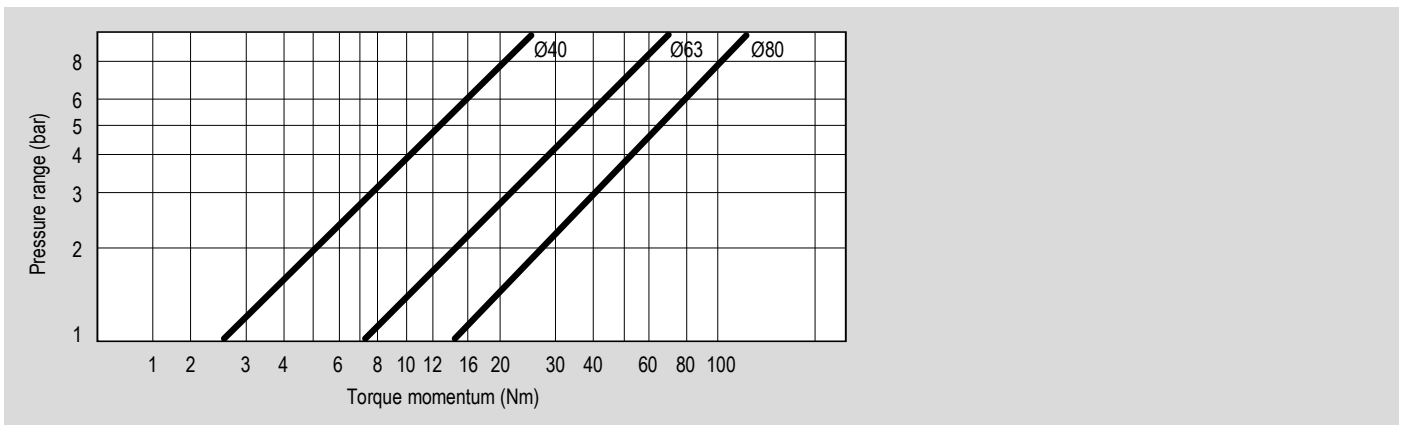

Air consumption for a complete circle

unit: litres/cycle

Ø (mm)	Rotation	Pressure range									
		1 bar	2 bar	3 bar	4 bar	5 bar	6 bar	7 bar	8 bar	9 bar	10 bar
40	90°	0,1571	0,2352	0,3133	0,3915	0,4696	0,5477	0,6259	0,7040	0,7821	0,8603
	180°	0,3141	0,4704	0,6267	0,7829	0,9392	1,0955	1,2517	1,4080	1,5643	1,7205
63	90°	0,4383	0,6564	0,8744	1,0925	1,3105	1,5286	1,7466	1,9647	2,1828	2,4008
	180°	0,8766	1,3127	1,7488	2,1850	2,6211	3,0572	3,4933	3,9294	4,3655	4,8016
80	90°	0,8480	1,2698	1,6917	2,1135	2,5354	2,9572	3,3791	3,8009	4,2228	4,6447
	180°	1,6959	2,5396	3,3834	4,2271	5,0708	5,9145	6,7582	7,6019	8,4456	9,2893

Dimensions

Type: **CRTH**

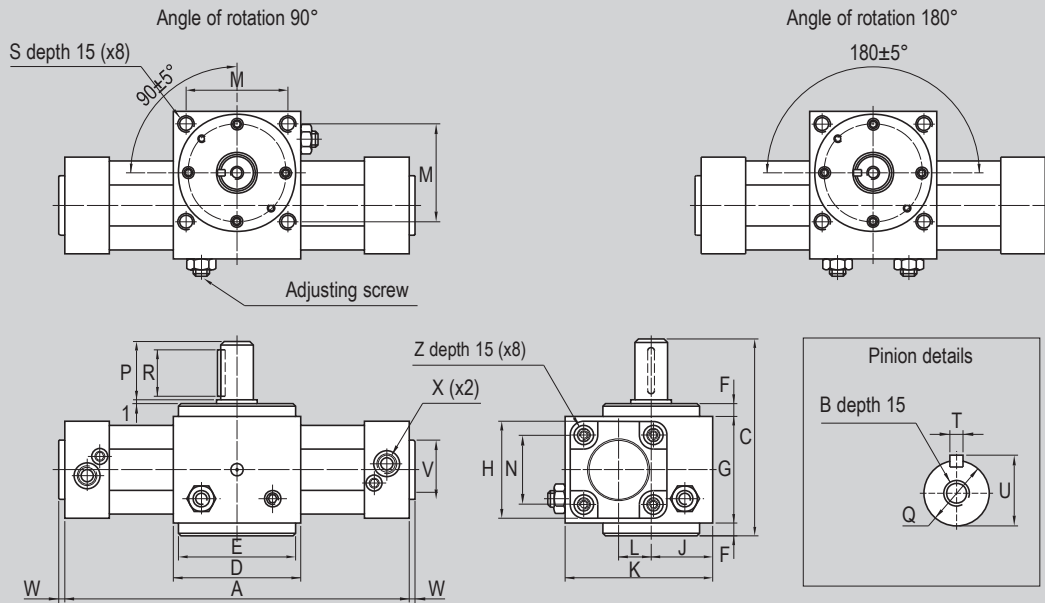

Ø (mm)	A		C	D	ØE	F	G	□H	J	K	L	M	□N	B	P	ØQ _{h6}	R	S	T	U	ØV	W	X	Z
	90°	180°																						
40	263	326	112	75	72	8	65	53	37,5	93	27,5	60	38	M5	30	16	25	M6	5	18	35	4	1/4"	M6
63	306	377	138	90	82	10	75	75	42,5	110	30	70	56,5	M8	42	24	36	M8	8	27	45	5	3/8"	M8
80	343	428	170	105	96	12	95	95	51,5	135	36	82	72	M8	50	28	45	M10	8	31	45	6	3/8"	M10

Type: **CRTHD**

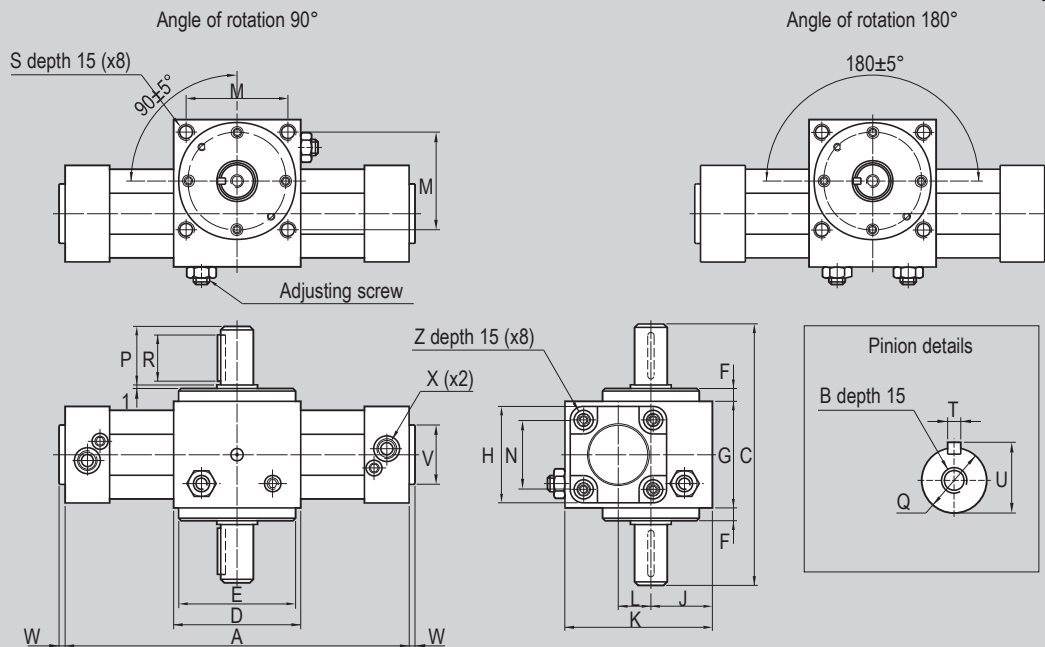

Ø (mm)	A		C	D	ØE	F	G	□H	J	K	L	M	□N	B	P	ØQ _{h6}	R	S	T	U	ØV	W	X	Z
	90°	180°																						
40	263	326	143	75	72	8	65	53	37,5	93	27,5	60	38	M5	30	16	25	M6	5	18	35	4	1/4"	M6
63	306	377	181	90	82	10	75	75	42,5	110	30	70	56,5	M8	42	24	36	M8	8	27	45	5	3/8"	M8
80	343	428	221	105	96	12	95	95	51,5	135	36	82	72	M8	50	28	45	M10	8	31	45	6	3/8"	M10

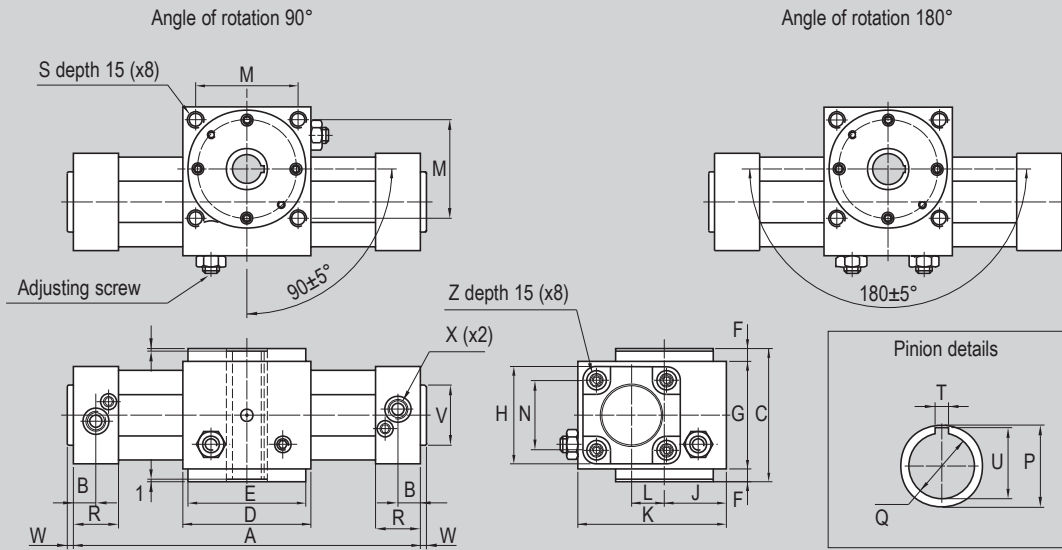

Dimensions

Type: CRTF



Ø (mm)	A		C	D	ØE	F	G	□H	J	K	L	M	□N	B	ØP	ØQ _{h7}	R	S	T	U	ØV	W	X	Z
	90°	180°																						
40	263	326	81	75	72	8	65	53	37,5	93	27,5	60	38	15	25	14	30	M6	5	16,5	35	4	1/4"	M6
63	306	377	95	90	82	10	75	75	42,5	110	30	70	56,5	16	30	19	32	M8	6	22	45	5	3/8"	M8
80	343	428	119	105	96	12	95	95	51,5	135	36	82	72	19	35	24	38	M10	6	27,5	45	6	3/8"	M10

Magnetic reed switch T groove ASV..

	For cylinder Ø mm	Code	Item	Cylinder matching*
	40 ÷ 80	070946 	ASV1C525	CRT..
		071863	ASV1C550	
		071864	ASV1C51K	
		071189	ASV1C5M8	
		073639	ASV4D225	
		070246 	ASV4D2M8	
		074900	ASV7N225	
		070247	ASV7N2M8	
		070372	ASV7M2M8	
		072918	ASV1H525	

Bracket AS.. (for magnetic reed switches T groove)

	For cylinder Ø mm	Code	Item	Cylinder matching
	40	072908	AS101	CRT..
	63	072909	AS102	
	80	072910	AS103	

*With bracket type AS.. for magnetic reed switches T groove

ROTARY VANE

Cylinders



Find out our
key products



Solution for most applications



Easy and intuitive choice



Excellent value for money



Wide availability



Fast delivery



Features and certifications

Series of rotary vane cylinders, available in bores from Ø 4 to 25, double acting, with reduced overall dimensions. With fixed and adjustable rotation angles and equipped with elastic dampers (hydraulic shock absorbers in adjustable versions for bores from Ø 12 to 25) to relieve the impacts of vanes. Supplied as standard in compliance with Reach and RoHS directives.



Type ARTM Ø 4 ÷ 10 from page 1.50.20



Rotary vane cylinders available in bores from Ø 4 to 10, double acting non-magnetic, with elastic dampers.
Rotation angle: 90°, 180° or 270°.



Type ARTMC Ø 4 ÷ 10 from page 1.50.20



Rotary vane cylinders available in bores from Ø 4 to 10, double acting magnetic, with elastic dampers.
Rotation angle: 90°, 180° or 270°



Type ARTML Ø 4 ÷ 10 from page 1.50.20



Rotary vane cylinders available in bores from Ø 4 to 10, double acting non-magnetic, with adjustable rotation angles and elastic dampers.
Rotation angle: 90°, 180° or 270°



Type ARTMLC Ø 4 ÷ 10 from page 1.50.20



Rotary vane cylinders available in bores from Ø 4 to 10, double acting magnetic, with adjustable rotation angles and elastic dampers.
Rotation angle: 90°, 180° or 270°



Type ARTMF Ø 4 ÷ 10 from page 1.50.40



Flanged rotary vane cylinders available in bores from Ø 4 to 10, double acting non-magnetic, with elastic dampers.
Rotation angle: 90°, 180° or 270°.



Type ARTMFC Ø 4 ÷ 10 from page 1.50.40



Flanged rotary vane cylinders available in bores from Ø 4 to 10, double acting magnetic, with elastic dampers.
Rotation angle: 90°, 180° or 270°



Type ARTMFL Ø 4 ÷ 10

from page 1.50.40



Flanged rotary vane cylinders available in bores from Ø 4 to 10, double acting non-magnetic, with adjustable rotation angles and elastic dampers.
Rotation angle: 90°, 180° or 270°



Type ARTMFLC Ø 4 ÷ 10

from page 1.50.40



Flanged rotary vane cylinders available in bores from Ø 4 to 10, double acting magnetic, with adjustable rotation angles and elastic dampers.
Rotation angle: 90°, 180° or 270°



Type ARTM Ø 12 ÷ 25

from page 1.50.60



Rotary vane cylinders available in bores from Ø 12 to 25, double acting non-magnetic, with elastic dampers.
Rotation angle: 90°, 180° or 270°.



Type ARTMC Ø 12 ÷ 25

from page 1.50.60



Rotary vane cylinders available in bores from Ø 12 to 25, double acting magnetic, with elastic dampers.
Rotation angle: 90°, 180° or 270°



Type ARTML Ø 12 ÷ 25

from page 1.50.60



Rotary vane cylinders available in bores from Ø 12 to 25, double acting non-magnetic, with adjustable rotation angles and hydraulic shock absorbers.
Rotation angle: 90°, 180° or 270°



Type ARTMLC Ø 12 ÷ 25

from page 1.50.60



Rotary vane cylinders available in bores from Ø 12 to 25, double acting magnetic, with adjustable rotation angles and hydraulic shock absorbers.
Rotation angle: 90°, 180° or 270°



Code key

Size	/	Angle of rotation	Type
30	/	90°	ARTM

10	= Ø 4
15	= Ø 5
20	= Ø 6
30	= Ø 8
40	= Ø 10
50	= Ø 12
63	= Ø 15
80	= Ø 17
100	= Ø 25

90°, 180°, 270°

ARTM Double acting Non-magnetic With fixed rotation angle
ARTMC Double acting Magnetic With fixed rotation angle
ARTML Double acting Non-magnetic With adjustable rotation angle
ARTMLC Double acting Magnetic With adjustable rotation angle
ARTMF⁽¹⁾ Flanged Double acting Non-magnetic With fixed rotation angle
ARTMFC⁽¹⁾ Flanged Double acting Magnetic With fixed rotation angle
ARTMFL⁽¹⁾ Flanged Double acting Non-magnetic With adjustable rotation angle
ARTMFLC⁽¹⁾ Flanged Double acting Magnetic With adjustable rotation angle

How to order

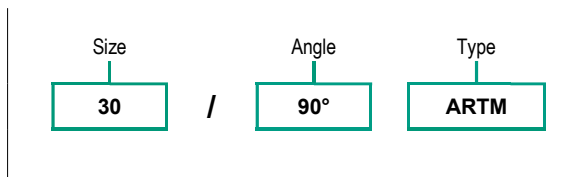

Note

For standard materials see page 1.50.5
 (1) Only for bores from Ø 4 to 10

Materiali standard

1 - CYLINDERS

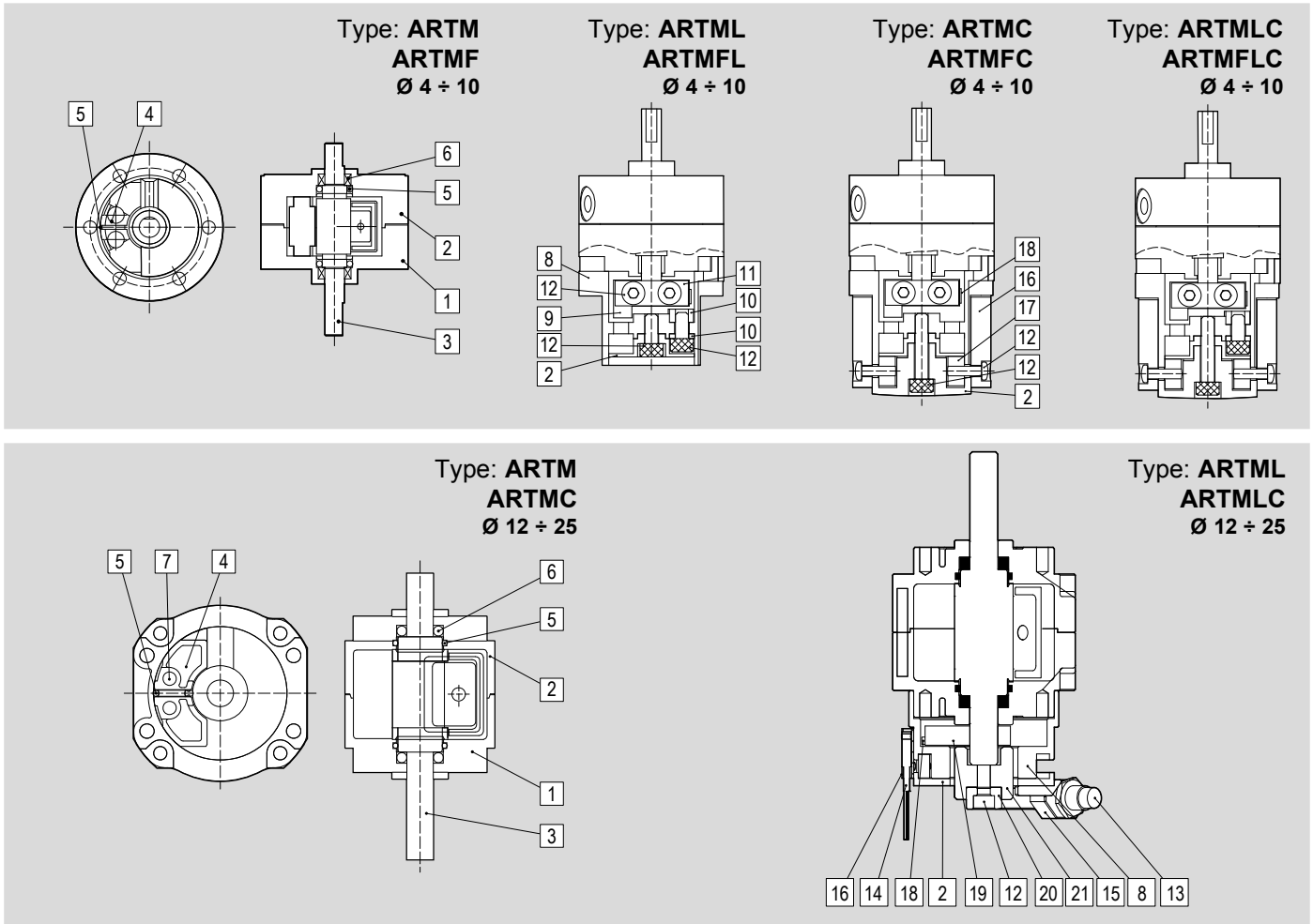

Posizione	Descrizione	Materiale	
		Ø 4 ÷ 10	Ø 20 ÷ 25
1	Front cover	Aluminium alloy	
2	End cover	Aluminium alloy	
3	Rod	Steel alloy	
4	Dampers	Plastic - Steel	
5	O-ring	NBR	
6	Bearing	Steel	
7	Position pin	-	Zinc alloy
8	Base	Zinc alloy	Stainless Steel
9	Stopper	Stainless Steel	-
10	Stopper base	Steel	-
11	Blocco	Stainless Steel	-
12	Screw	Steel alloy	Stainless Steel
13	Shoche absorber (x2)	-	Steel alloy
14	Magnetic reed switch	-	Steel alloy
15	Angle adjustment	-	Aluminium
16	Mounting base	Aluminium alloy	
17	Base and lump	Aluminium alloy	-
18	Magnet	TME	Steel alloy
19	Magnet seat	-	Steel alloy
20	Rocker arm	-	Steel
21	Rocker arm seat	-	Steel

Accessories

Type: **ARTM..**
Ø 4 ÷ 10

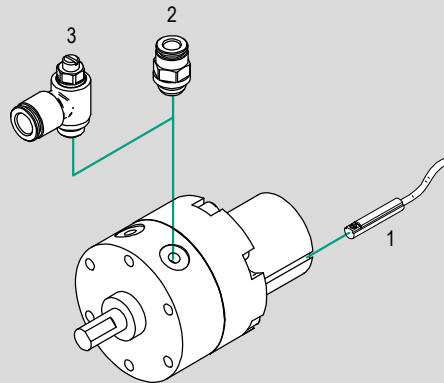

Type: **ARTM..**
Ø 12 ÷ 25

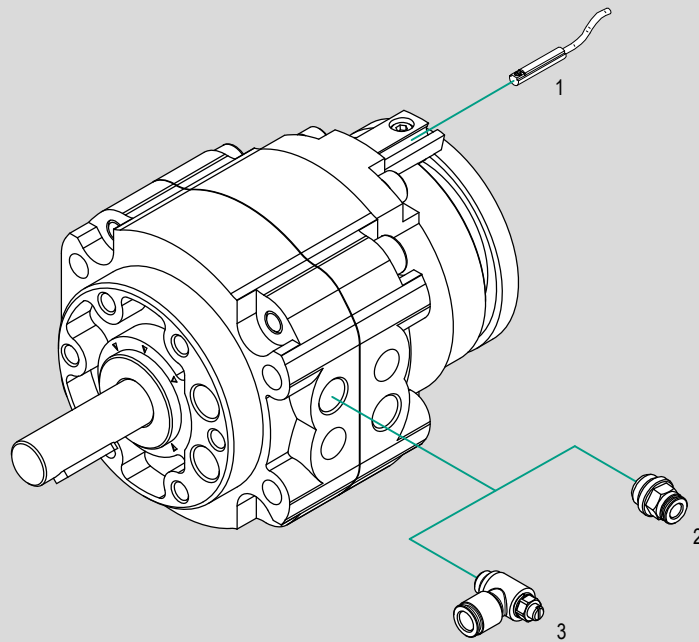



N.	Cylinder bore	Item	Description	Compliance	Matching				Code page	Data sheet page
					ARTM ARTMF	ARTMC ARTMFC	ARTML ARTMFL	ARTMLC ARTMFLC		
1	Ø 4 ÷ 25	ASC..	Magnetic reed switch C groove	-	-	●	-	●	1.50.90	1.110.30
2	Ø 4 ÷ 25	R..	Push-in fittings		●	●	●	●	4.2.1	
3	Ø 4 ÷ 25	V..C	Flow controls, for cylinders		●	●	●	●	4.94.1	



Key

● allowed matching; - not allowed matching

Main features



4 ÷ 10  **ARTM** 

Bores Ø Double acting Non magnetic Type



4 ÷ 10  **ARTMC** 

Bores Ø Double acting Magnetic Type

Main features

4 ÷ 10  **ARTML** 

Bores Ø Double acting Non magnetic Adjustable angle Type

4 ÷ 10  **ARTMLC** 

Bores Ø Double acting Magnetic Adjustable angle Type

Technical data

Size	10	15	20	30	40	
Bore	Ø 4	Ø 5	Ø 6	Ø 8	Ø 10	
Fluid	Filtered compressed air with or without lubrication. Lubrication, if started, must be continued.					
Angle of rotation	90° - 180° - 270°					
Pressure range	1,5 ÷ 7 bar					
Temperature range	0°C ÷ +50°C					
Ports	M5					
Torque momentum (Nm) at 6 bar	0,14	0,38	0,81	1,8	3,8	
Admissible kinetic energy (J)	0,0015	0,001	0,003	0,02	0,04	
Weight (g)	ARTM	28	48	112	200	342
	ARTMC	78	116	240	390	604
	ARTML ARTMLC					

Output torque table

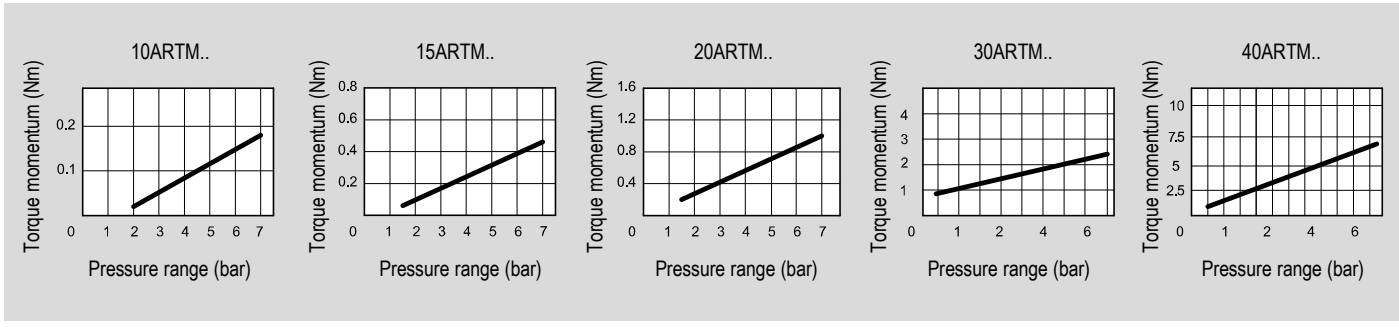

Assembly type

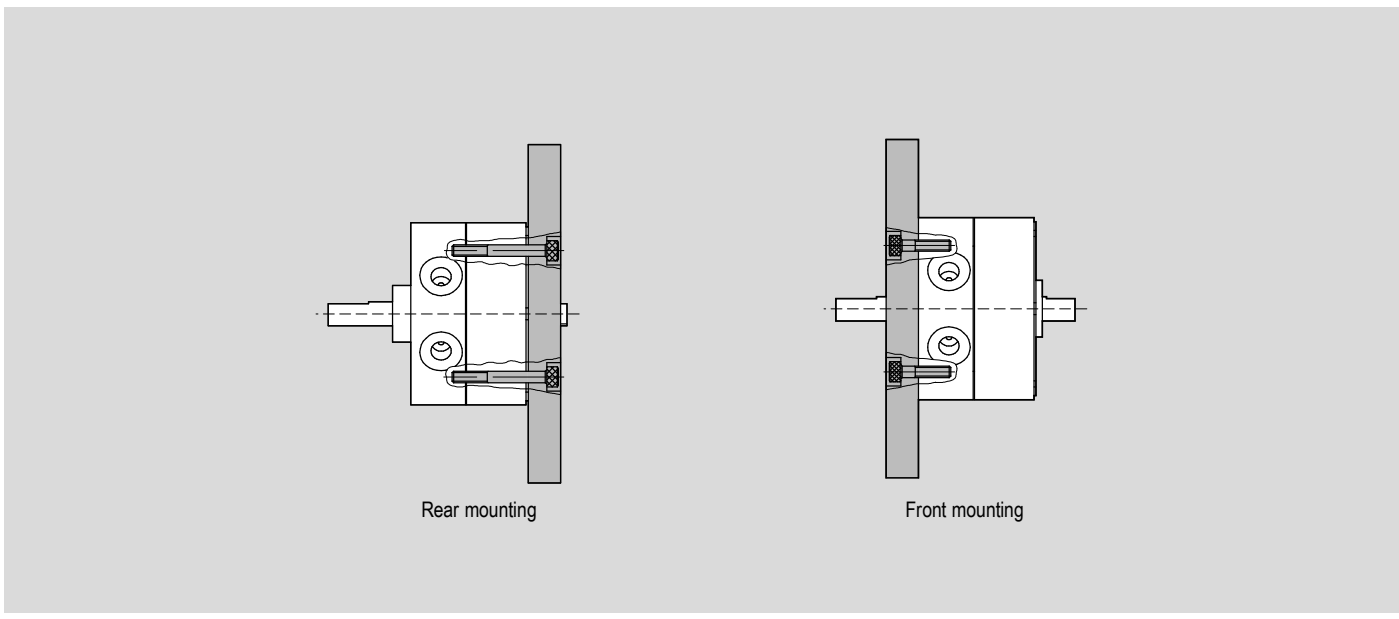

Angle of rotation

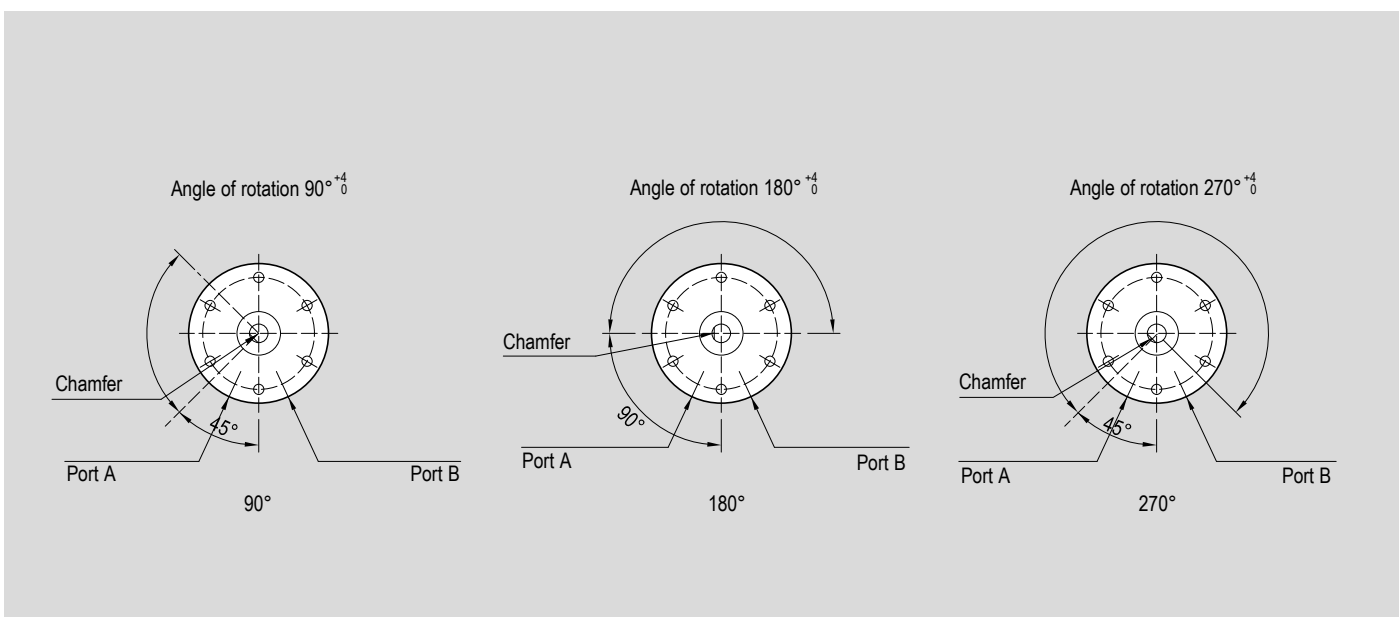

Rotation angle settings

1 - CYLINDERS

90° rotation setting

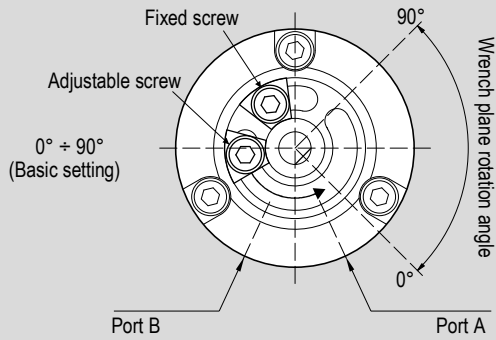

180° rotation setting

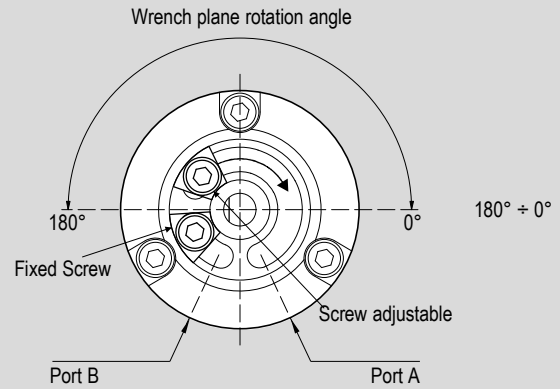
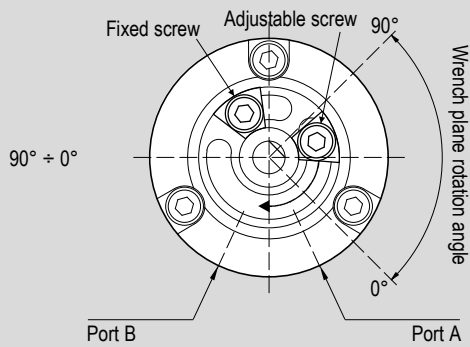
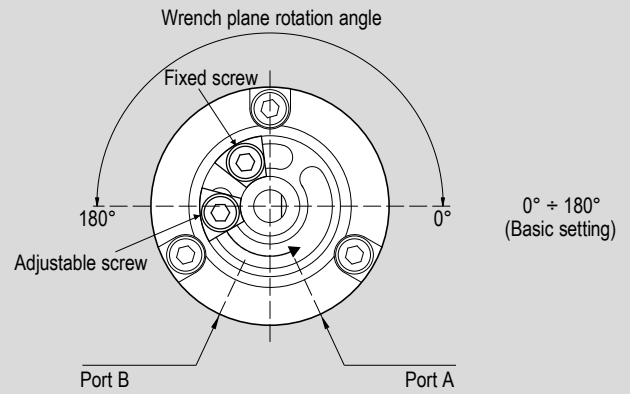

270° rotation setting

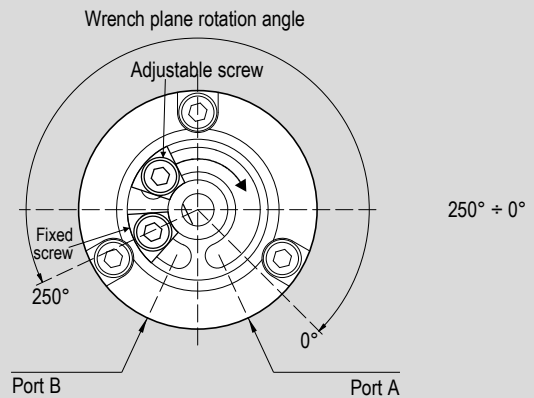
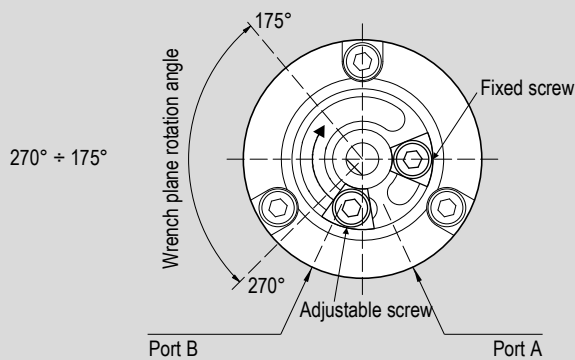
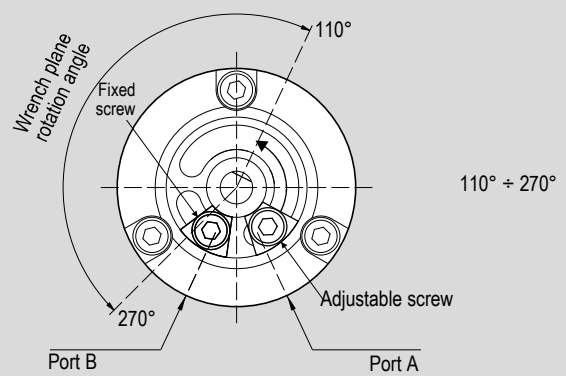
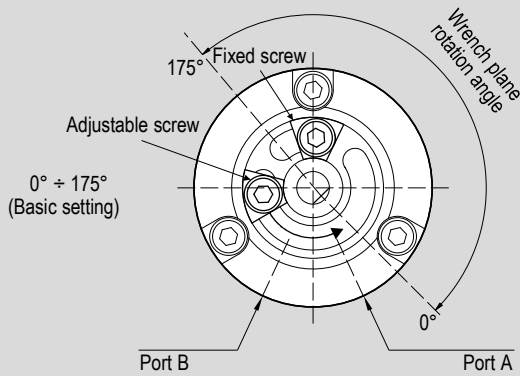

Dimensions

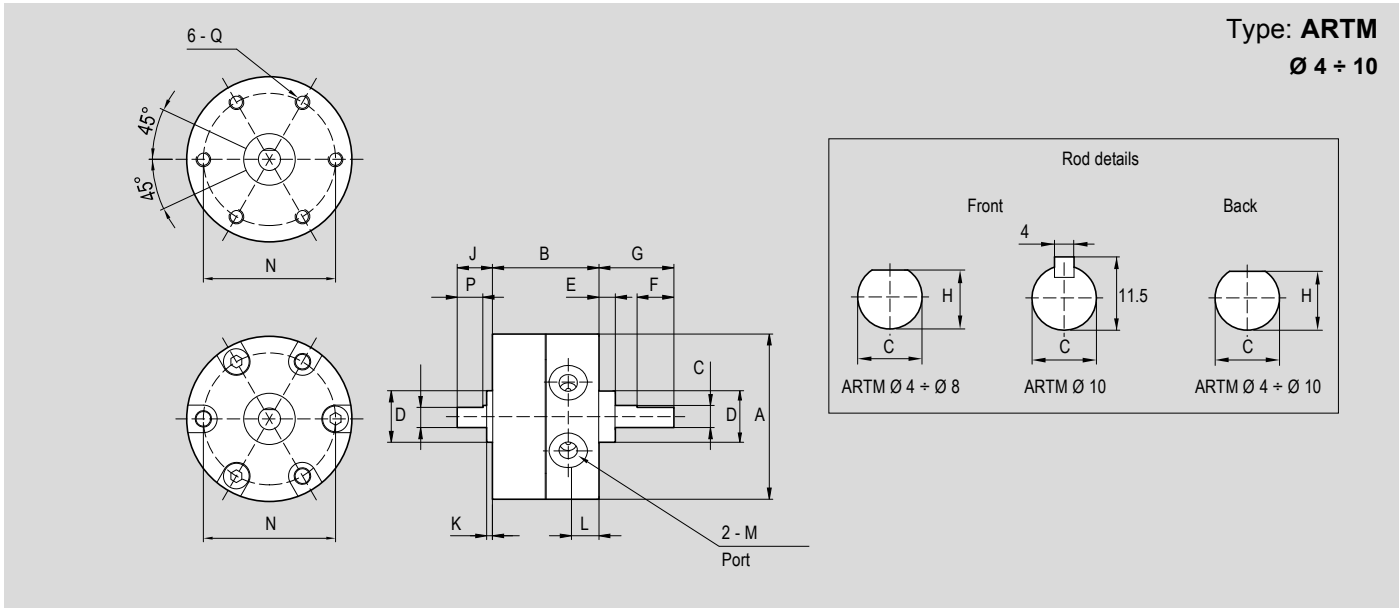

Type: **ARTM**
Ø 4 ÷ 10

Ø (mm)	size	ØA	B	ØC	ØD	E	F	G	H	P	J	K	L	M	ØN	Q
4	10	30	17	4	9	3	9	14	3,5	5	8	1	4,2	M5x0,8	24	M3x0,5
5	15	3	20,1	5	12	4	10	18	4,5	6	9	1,5	5	M5x0,8	29	M3x0,5
6	20	44	29,1	6	14	4,5	10	20,3	5,5	7	9,6	1,6	8,5	M5x0,8	36	M4x0,7
8	30	51	40	8	16	5	12	22	7,5	8	13	2	11	M5x0,8	43	M5x0,8
10	40	64	45	10	25	6,5	22	30	9	9	15	4,5	9,5	M5x0,8	56	M5x0,8

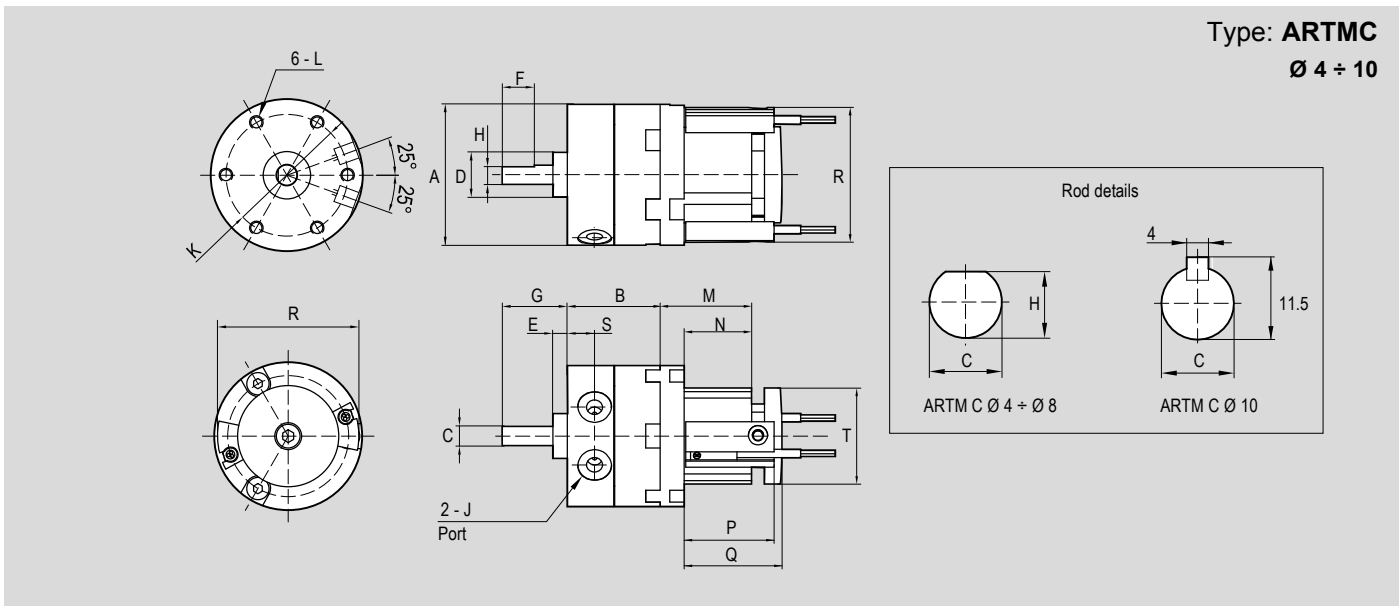

Type: **ARTMC**
Ø 4 ÷ 10

Ø (mm)	size	ØA	B	ØC	ØD	E	F	G	H	S	J	ØK	L	M	N	ØT	P	Q	ØR
4	10	30	17	4	9	3	9	14	3,5	4,2	M5x0,8	24	M3x0,5	24	18	18	23,3	24	29
5	15	35	20,1	5	12	4	10	18	4,5	5	M5x0,8	29	M3x0,5	28	22	24	27,3	29,5	34
6	20	44	29,1	6	14	4,5	10	20,3	5,5	8,5	M5x0,8	36	M4x0,7	28,5	21	30	28	30,5	42
8	30	51	40	8	16	5	12	22	7,5	11	M5x0,8	43	M5x0,8	32,5	24	34	30,8	34	47
10	40	64	45	10	25	6,5	22	30	-	9,5	M5x0,8	56	M5x0,8	34,5	26	34	33	36	47

Dimensions

Type: **ARTML**
Ø 4 ÷ 10

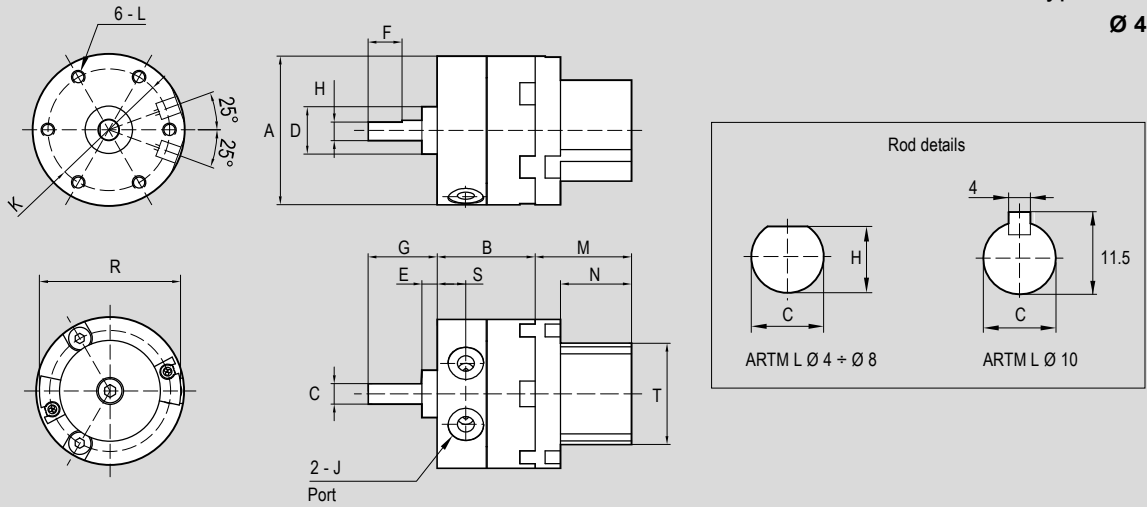



Ø (mm)	size	ØA	B	ØC	ØD	E	F	G	H	S	J	K	L	M	N	ØT	ØR
4	10	30	17	4	9	3	9	14	3,5	4,2	M5x0,8	24	M3x0,5	24	18	18	29
5	15	35	20,1	5	12	4	10	18	4,5	5	M5x0,8	29	M3x0,5	28	22	24	34
6	20	44	29,1	6	14	4,5	10	20,3	5,5	8,5	M5x0,8	36	M4x0,7	28,5	21	30	42
8	30	51	40	8	16	5	12	22	7,5	11	M5x0,8	43	M5x0,8	32,5	24	34	47
10	40	64	45	10	25	6,5	22	30	-	9,5	M5x0,8	56	M5x0,8	34,5	26	34	47

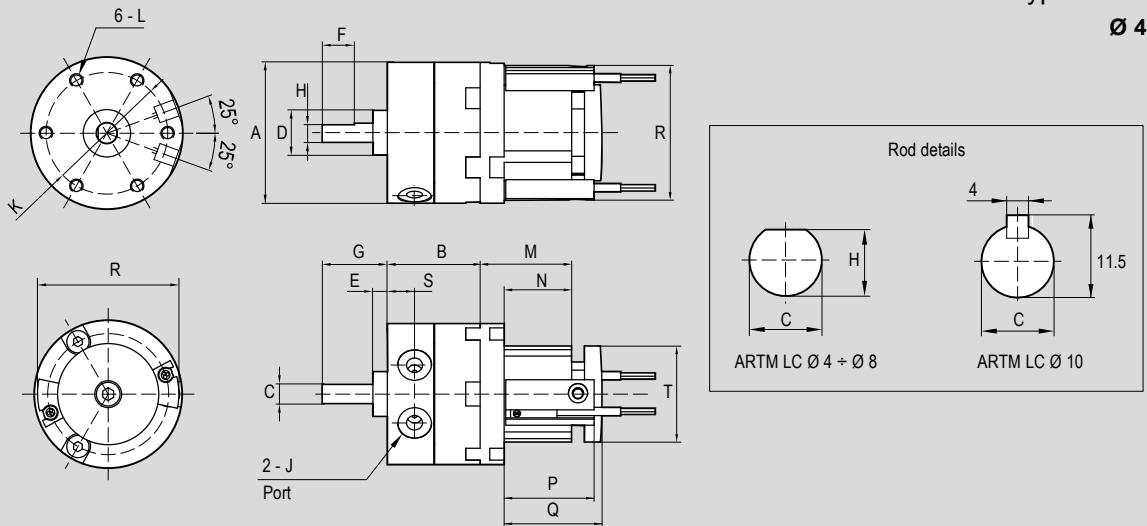

Type: **ARTMLC**
Ø 4 ÷ 10





Ø (mm)	size	ØA	B	ØC	ØD	E	F	G	H	S	J	ØK	L	M	N	ØT	P	Q	ØR
4	10	30	17	4	9	3	9	14	3,5	4,2	M5x0,8	24	M3x0,5	24	18	18	23,3	24	29
5	15	35	20,1	5	12	4	10	18	4,5	5	M5x0,8	29	M3x0,5	28	22	24	27,3	29,5	34
6	20	44	29,1	6	14	4,5	10	20,3	5,5	8,5	M5x0,8	36	M4x0,7	28,5	21	30	28	30,5	42
8	30	51	40	8	16	5	12	22	7,5	11	M5x0,8	43	M5x0,8	32,5	24	34	30,8	34	47
10	40	64	45	10	25	6,5	22	30	-	9,5	M5x0,8	56	M5x0,8	34,5	26	34	33	36	47



Main features

4 ÷ 10  **ARTMF** 
Bores Ø Double acting Non magnetic Type

4 ÷ 10  **ARTMFC** 
Bores Ø Double acting Magnetic Type

Main features

4 ÷ 10  **ARTMFL** 
Bores Ø Double acting Non magnetic Adjustable angle Type

4 ÷ 10  **ARTMFLC** 
Bores Ø Double acting Magnetic Adjustable angle Type

Technical data

Size	10	15	20	30	40	
Bore	Ø 4	Ø 5	Ø 6	Ø 8	Ø 10	
Fluid	Filtered compressed air with or without lubrication. Lubrication, if started, must be continued.					
Angle of rotation	90° - 180° - 270°					
Pressure range	1,5 ÷ 7 bar					
Temperature range	0°C ÷ +50°C					
Ports	M5					
Torque momentum (Nm) at 6 bar	0,14	0,38	0,81	1,8	3,8	
Admissible kinetic energy (J)	0,0015	0,001	0,003	0,02	0,04	
Weight (g)	ARTMF	41	70	138	268	438
	ARTMFC ARTMFL ARTMFLC	91	138	266	468	700

Output torque table

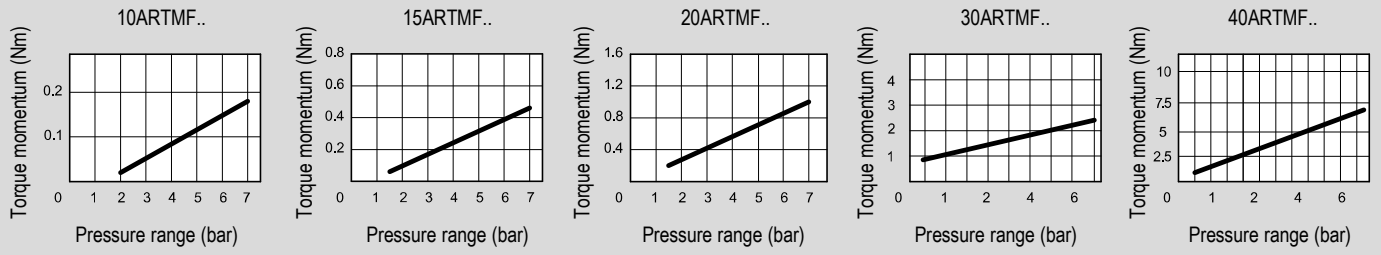

Assembly type

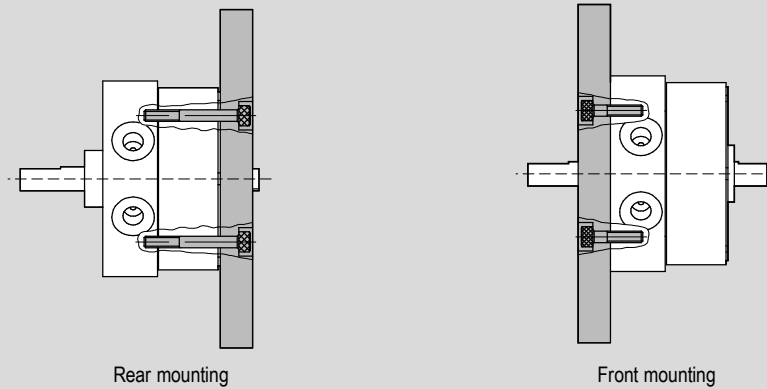

Angle of rotation

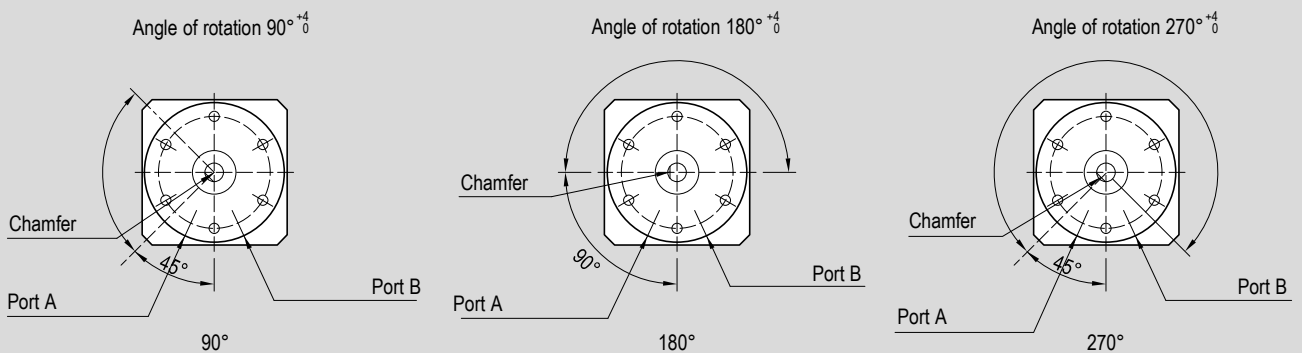

Rotation angle settings

1 - CYLINDERS

90° rotation setting

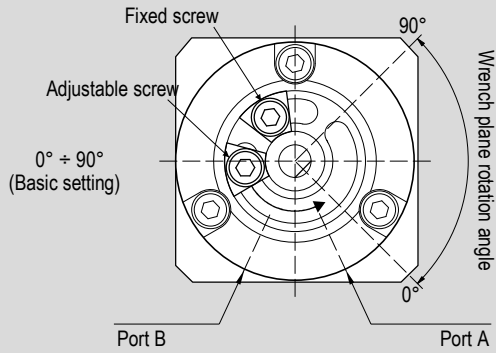

180° rotation setting

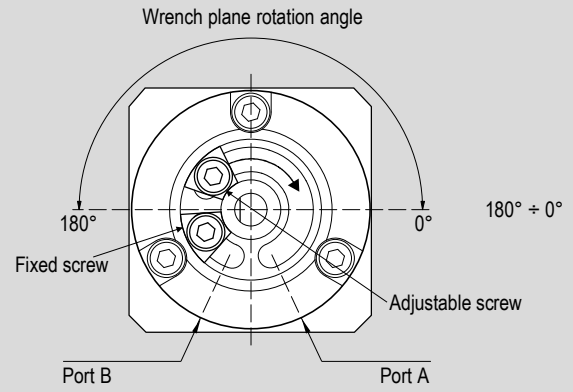
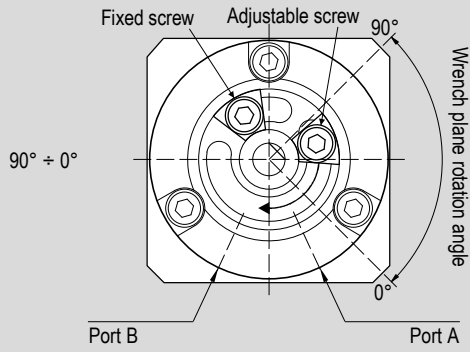
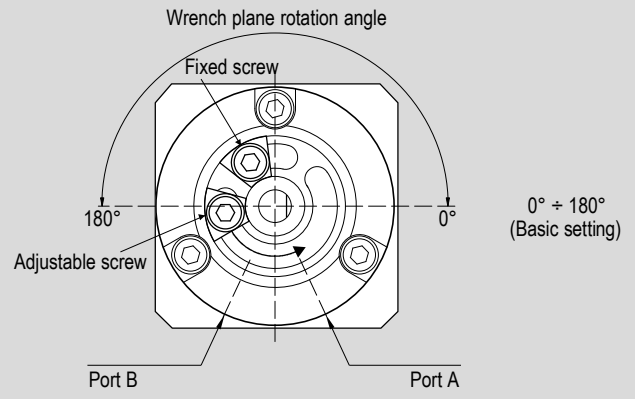

270° rotation setting

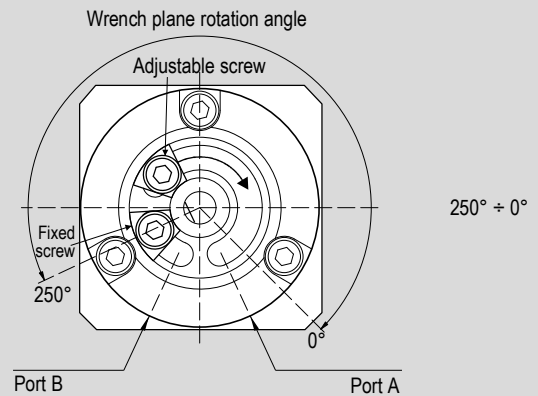
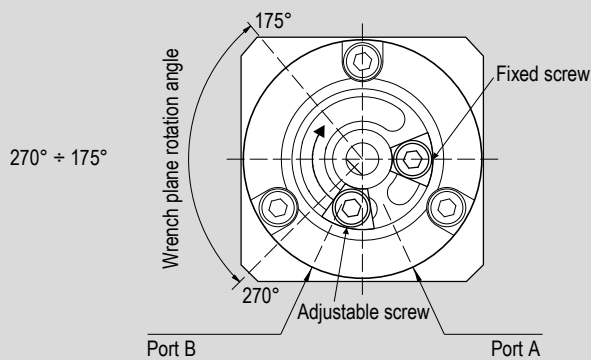
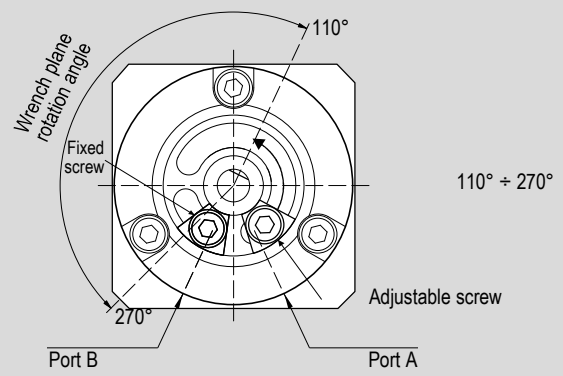
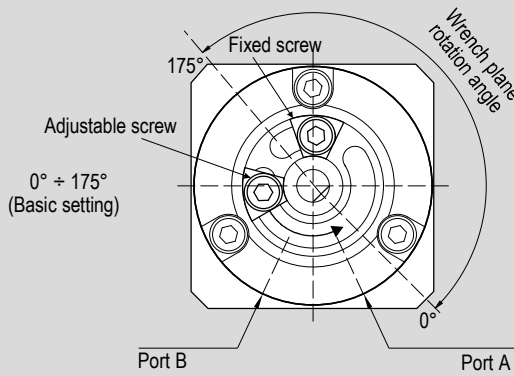

Dimensions

Type: **ARTMF**
Ø 4 ÷ 10

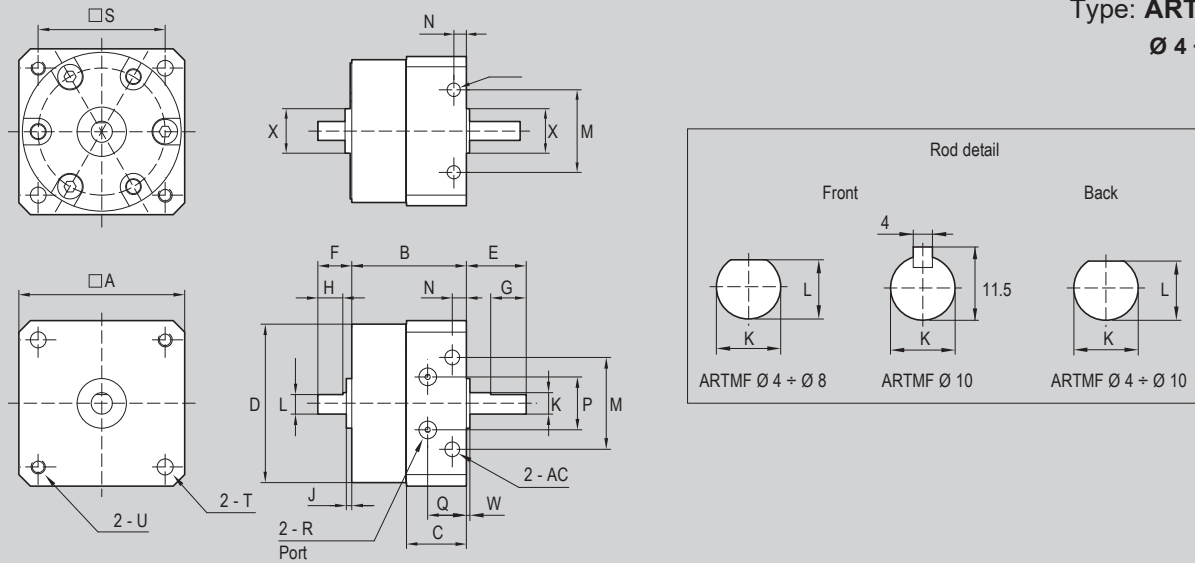

Ø (mm)	size	□A	B	C	ØD	E	F	G	H	ØX	J	ØK	L	M	N	AC	P	Q	R	□S	T	U	V	W
4	10	31	22	13,3	30	14	8	9	5	9	1	4	3,5	17	3	3,5	10,5	9,2	M5x0,8	25	3,5	M3x0,5	24	1
5	15	36	25,7	15,5	35	18	9	10	6	12	1,5	5	4,5	21	3	3,5	10,5	10,5	M5x0,8	29	3,5	M3x0,5	29	1,5
6	20	44	33,6	19	44	20	10	10	7	14	1,6	6	5,5	26	4	4,2	15	13	M5x0,8	36	4,5	M4x0,7	36	1
8	30	52	47,5	27,2	51	22	13	12	8	16	2	8	7,5	29	4,5	5,5	13,5	18,5	M5x0,8	42	5,5	M5x0,8	43	2
10	40	64	53	30,4	64	30	15	22	9	25	4,5	10	9	38	5	5,5	19	14	M5x0,8	52	5,5	M5x0,8	56	3

Type: **ARTMFC**
Ø 4 ÷ 10

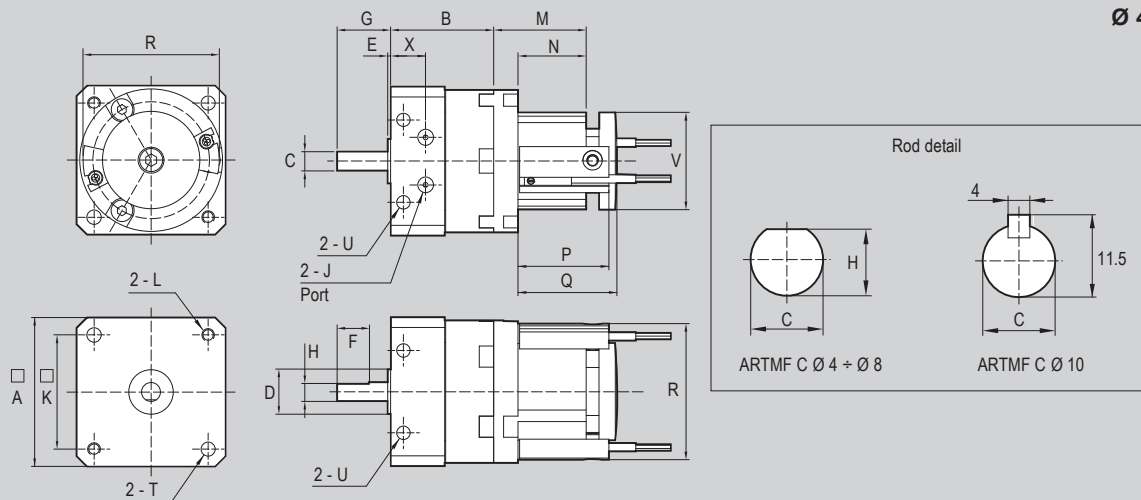

Ø (mm)	size	□A	B	ØC	ØD	E	F	G	H	X	J	□K	L	M	N	ØV	P	Q	ØR	S	T	U
4	10	31	22	4	9	1	9	14	3,5	9,2	M5x0,8	25	M3x0,5	24	18	18	23,3	24	29	30	3,5	3,5
5	15	36	25,7	5	12	1,5	10	18	4,5	10,5	M5x0,8	29	M3x0,5	28	22	24	27,3	29,5	34	35	3,5	3,5
6	20	44	33,6	6	14	1	10	20	5,5	13	M5x0,8	36	M4x0,7	28,5	21	30	28	30,5	42	44	4,5	4,2
8	30	52	47,5	8	16	2	12	22	7,5	18,5	M5x0,8	42	M5x0,8	32,5	24	34	30,8	34	47	51	5,5	5,5
10	40	64	53	10	25	3	22	30	-	14	M5x0,8	52	M5x0,8	34,5	26	34	33	36	47	64	5,5	5,5

1 - CYLINDERS

Dimensions

Type: **ARTMFL**
Ø 4 ÷ 10

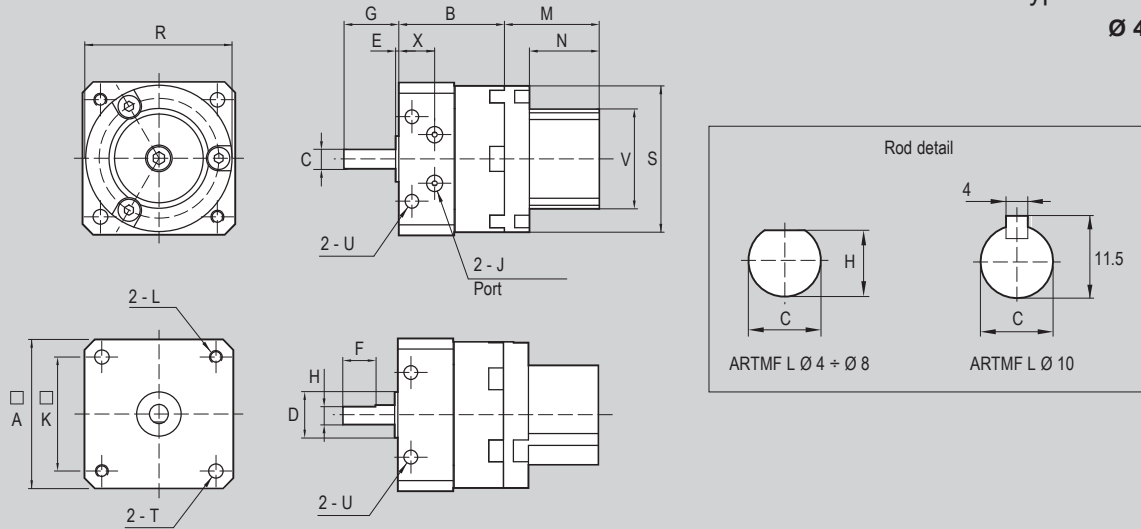

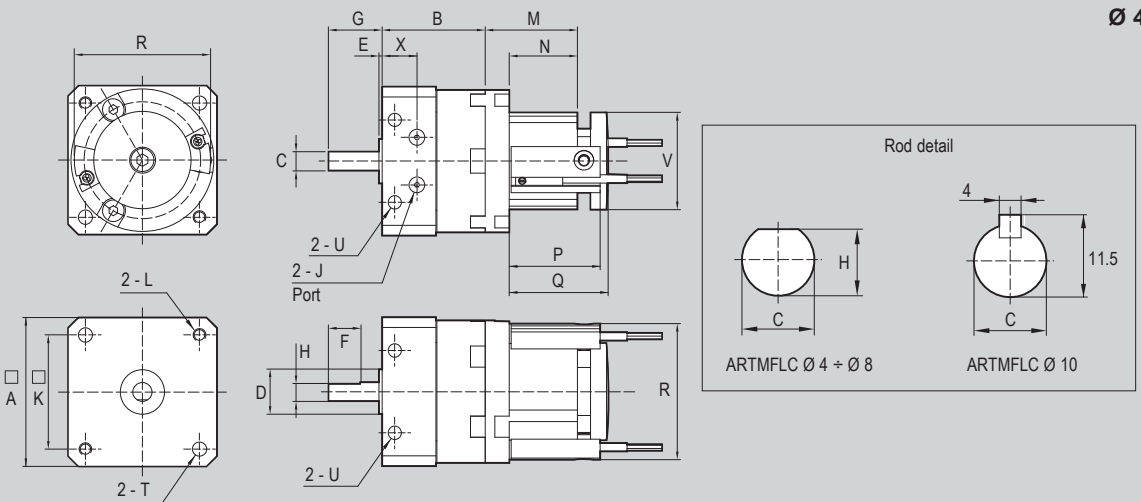

Ø (mm)	size	□A	B	ØC	ØD	E	F	G	H	X	J	□K	L	M	N	ØV	P	Q	ØR	ØS	T	U
4	10	31	22	4	9	1	9	14	3,5	9,2	M5x0,8	25	M3x0,5	24	18	18	23,3	24	29	30	3,5	3,5
5	15	36	25,7	5	12	1,5	10	18	4,5	10,5	M5x0,8	29	M3x0,5	28	22	24	27,3	29,5	34	35	3,5	3,5
6	20	44	33,6	6	14	1	10	20	5,5	13	M5x0,8	36	M4x0,7	28,5	21	30	28	30,5	42	44	4,5	4,2
8	30	52	47,5	8	16	2	12	22	7,5	18,5	M5x0,8	42	M5x0,8	32,5	24	34	30,8	34	47	51	5,5	5,5
10	40	64	53	10	25	3	22	30	-	14	M5x0,8	52	M5x0,8	34,5	26	34	33	36	47	64	5,5	5,5

Type: **ARTMFLC**
Ø 4 ÷ 10





Ø (mm)	size	□A	B	ØC	ØD	E	F	G	H	X	J	□K	L	M	N	ØV	P	Q	ØR	ØS	T	U
4	10	31	22	4	9	1	9	14	3,5	9,2	M5x0,8	25	M3x0,5	24	18	18	23,3	24	29	30	3,5	3,5
5	15	36	25,7	5	12	1,5	10	18	4,5	10,5	M5x0,8	29	M3x0,5	28	22	24	27,3	29,5	34	35	3,5	3,5
6	20	44	33,6	6	14	1	10	20	5,5	13	M5x0,8	36	M4x0,7	28,5	21	30	28	30,5	42	44	4,5	4,2
8	30	52	47,5	8	16	2	12	22	7,5	18,5	M5x0,8	42	M5x0,8	32,5	24	34	30,8	34	47	51	5,5	5,5
10	40	64	53	10	25	3	22	30	-	14	M5x0,8	52	M5x0,8	34,5	26	34	33	36	47	64	5,5	5,5

Main features



12 ÷ 25  **ARTM** 

Bores Ø Double acting Non magnetic Type



12 ÷ 25  **ARTMC** 

Bores Ø Double acting Magnetic Type

Main features

12 ÷ 25  **ARTML** 

Bores Ø Double acting Non magnetic Adjustable angle Type

12 ÷ 25  **ARTMLC** 

Bores Ø Double acting Magnetic Adjustable angle Type

Technical data

Size	50	63	80	100	
Bore	Ø 12	Ø 15	Ø 17	Ø 25	
Fluid	Filtered compressed air with or without lubrication. Lubrication, if started, must be continued.				
Angle of rotation	90° - 180° - 270°				
Pressure range	1,5 ÷ 7 bar				
Temperature range	0°C ÷ +50°C				
Ports	1/8"		1/4"		
Torque momentum (Nm) at 6 bar	5	10	18	35	
Admissible kinetic energy (J)	0,082	0,12	0,39	0,6	
Weight (g)	ARTM ARTMC	760	1290	1920	3560
	ARTML ARTMLC	1100	1500	2300	3900

Output torque table

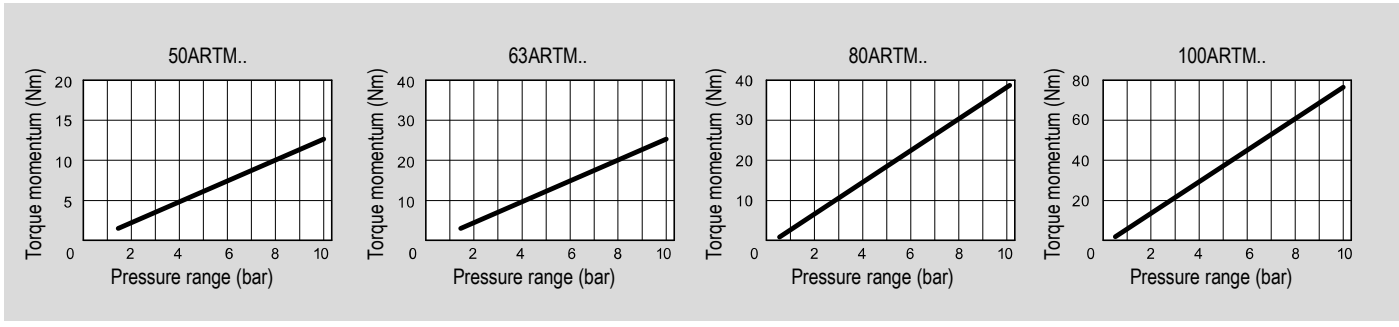

Angle of rotation

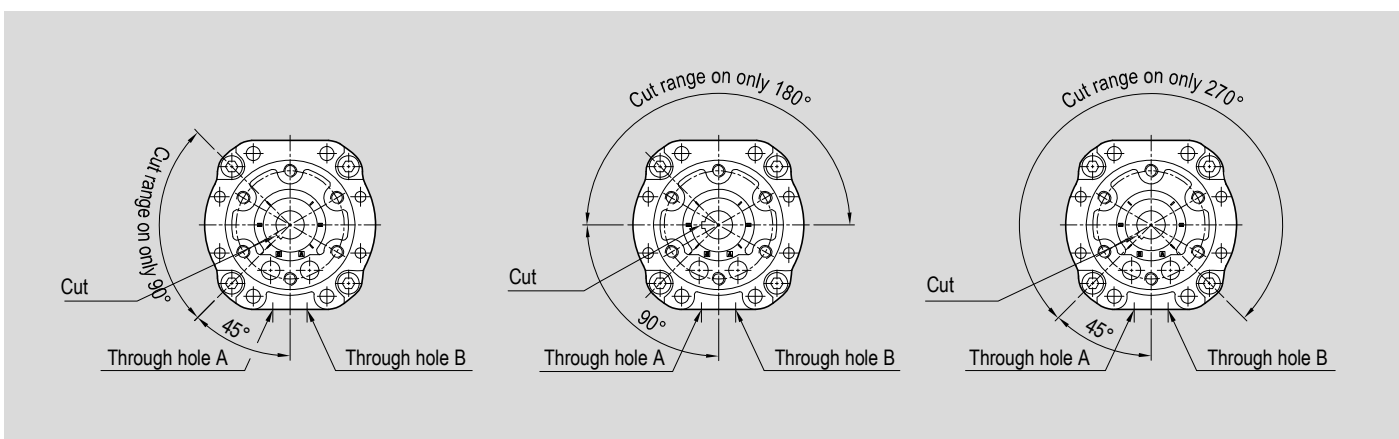

Angle of rotation*

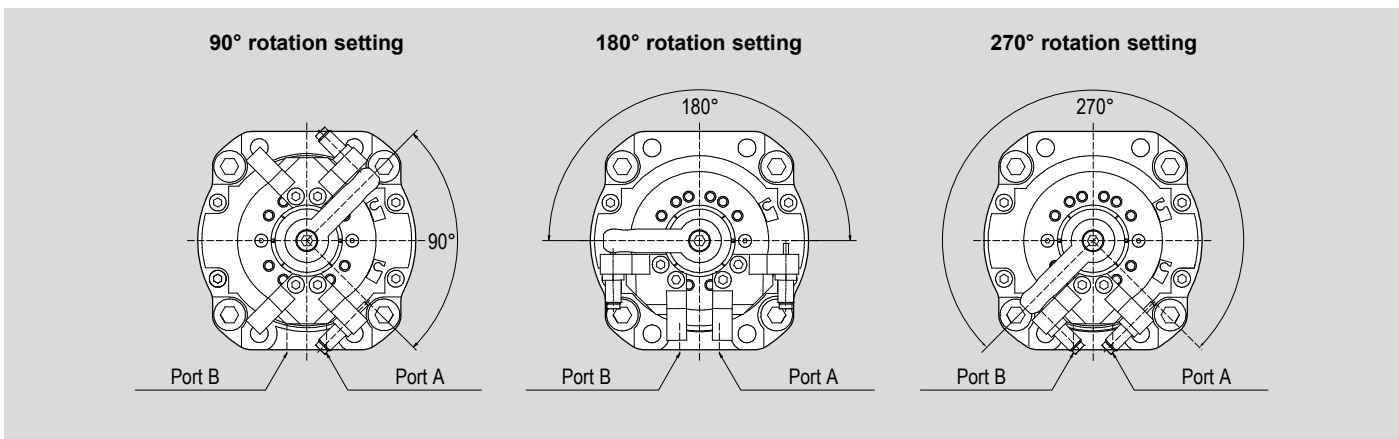

*With shock absorbers for 10° rotation adjustment

Assembly type

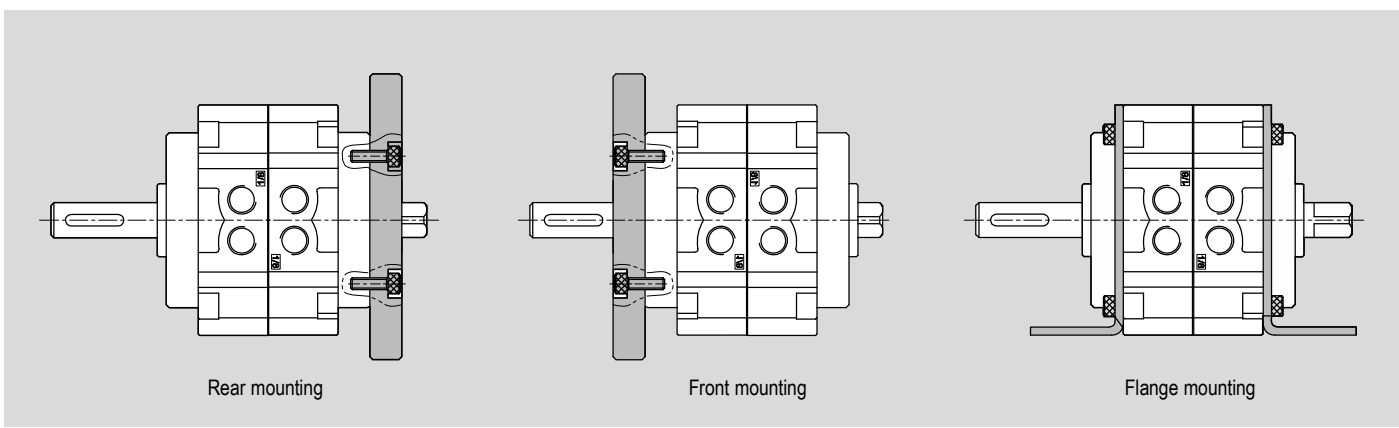

Dimensions

Type: **ARTM**
Ø 12 ÷ 25

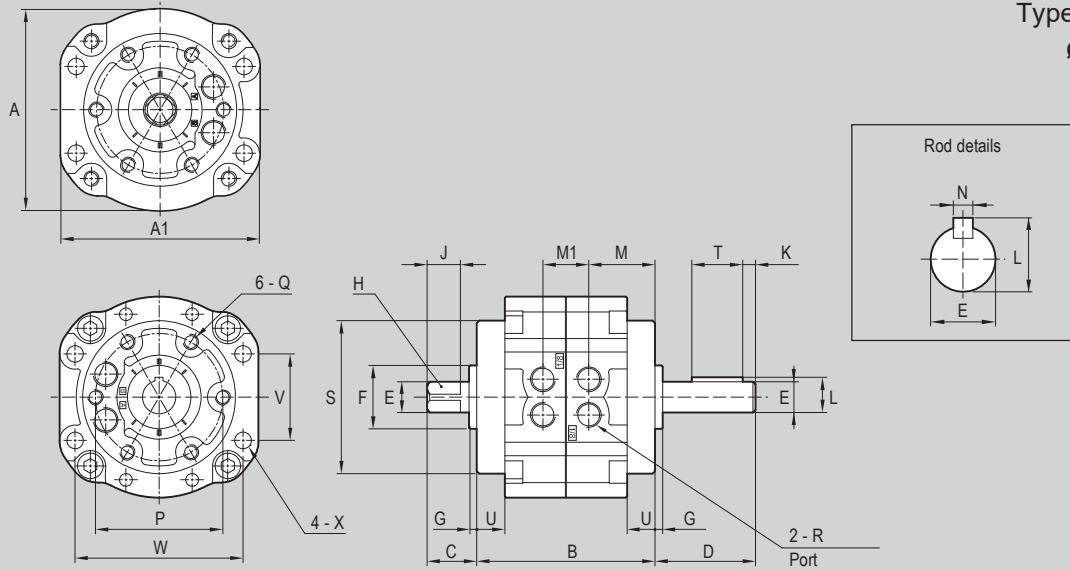

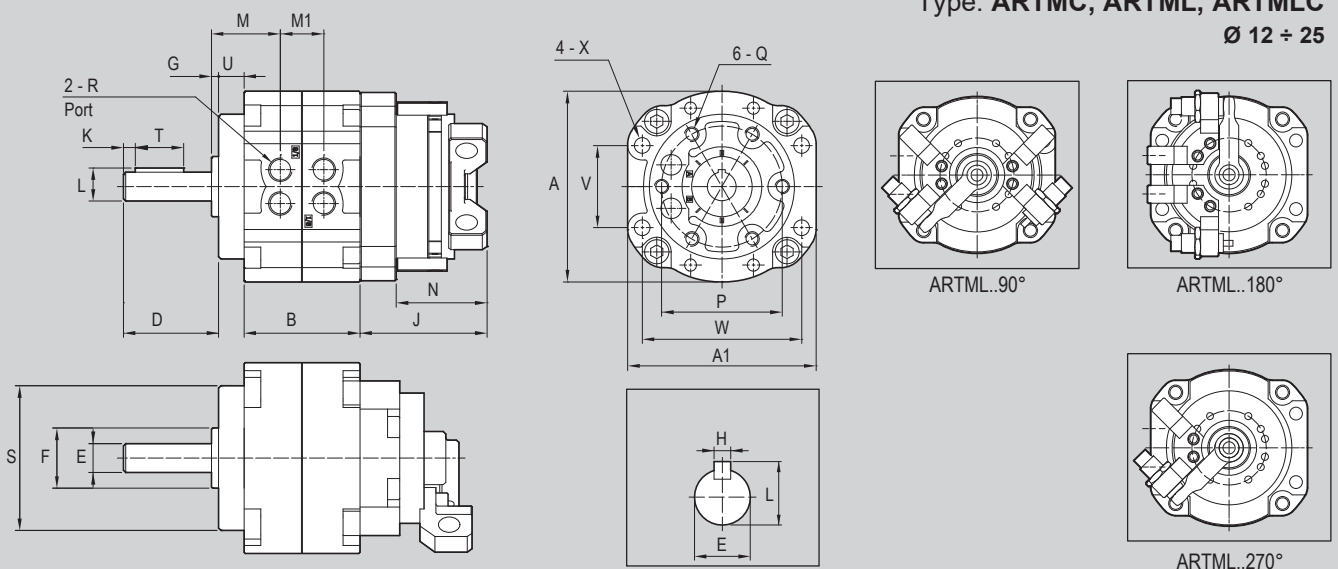

Ø (mm)	size	ØA	A1	B	C	D	ØE	ØF	G	H	N	J	K	L	M	M1	ØP	Q	R	ØS	T	U	V	W	ØX
12	50	79	78	70	19,5	39,5	12	25	3	10	4	13	5	13,5	26	18,2	50	M6x1,0	RC1/8"	60	20	11	34	66	6,5
15	63	98	98	80	21	45	15	28	3	12	5	14	5	17	28,9	22,2	60	M8x1,25	RC1/8"	75	25	14	39	83	9
17	80	110	110	90	23,5	53,5	17	30	3	13	5	16	5	19	30	30,2	70	M8x1,25	RC1/4"	88	41	15	48	94	9
25	100	140	140	103	30	65	25	45	4	19	7	22	5	28	35,4	32,2	80	M10x1,5	RC1/4"	108	40	11,5	60	120	11

Type: **ARTMC, ARTML, ARTMLC**
Ø 12 ÷ 25



Ø (mm)	size	ØA	A1	B	D	ØE	ØF	G	H	J	K	L	M	M1	N	ØP	Q	R	ØS	T	U	V	W	ØX
12	50	79	78	48	50,5	12	25	3	4	52,7	5	13,5	29	18	37,7	50	M6x1,0	RC1/8"	60	20	11	34	66	6,5
15	63	98	98	52	59	15	28	3	5	56,4	5	17	31,9	22,2	37,7	60	M8x1,25	RC1/8"	75	25	14	39	83	9
17	80	110	110	60	68,5	17	30	3	5	58,9	5	19	33	30	39,2	70	M8x1,25	RC1/4"	88	36	15	48	94	9
25	100	140	140	80	76,5	25	45	4	7	62,9	5	28	39,4	32,2	39,2	90	M10x1,5	RC1/4"	108	40	11,5	60	120	11

Magnetic reed switch C groove ASC..

	For cylinder Ø mm	Code	Item	Cylinder matching
	4 ÷ 25	070248 	ASC1C525	ARTMC
		070249	ASC7N2M8	ARTMLC
		070382	ASC7M2M8	ARTMFC ARTMFLC

ROTARY

Actuators

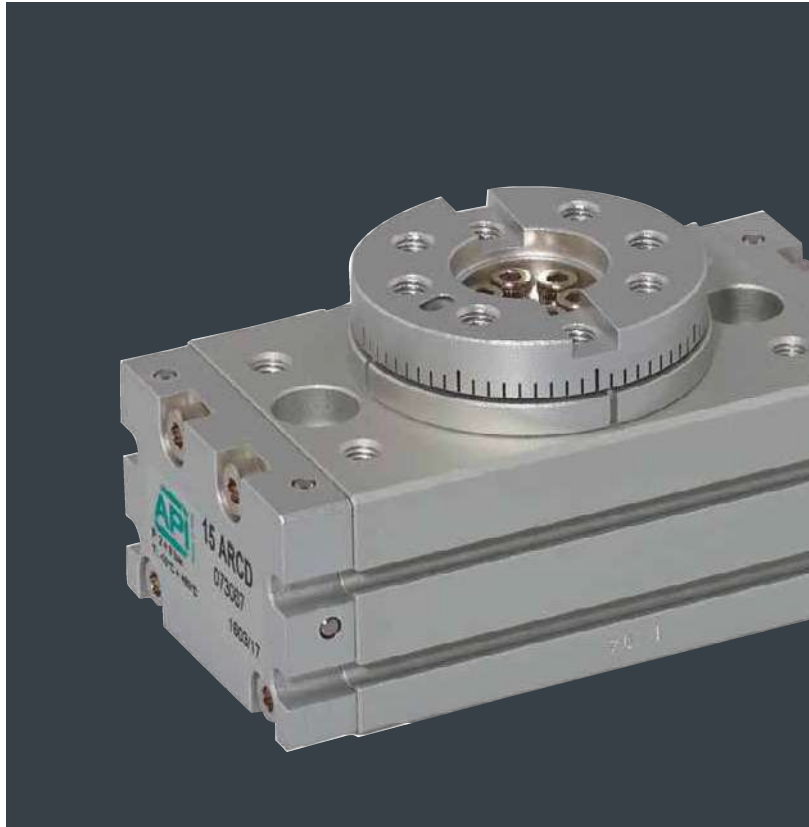

Find out our
key products



Solution for most applications



Easy and intuitive choice



Excellent value for money



Wide availability



Fast delivery



Features and certifications

Series of rotary actuators, available in bores from Ø 10 to 63, double acting, magnetic. Supplied as standard in compliance with Reach and RoHS directives.



Type ARC Ø 10 ÷ 63

from page 1.52.20



Rotary actuators with double rack, with rotation angles $90^\circ \div 180^\circ$ and adjustment $0^\circ \div 190^\circ$. Double acting, magnetic, with grooves on the body allowing the direct mounting of magnetic reed switches. Equipped as standard with mechanical stoppers, on request these can be supplied with hydraulic shock absorbers.



Type ARP Ø 15 ÷ 32

from page 1.52.50



Rotary actuators with piston and external mechanical stoppers. Rotation angles 90° and 180° . Double acting, magnetic, with grooves on the body allowing the direct mounting of magnetic reed switches. Equipped as standard with mechanical stoppers, on request these can be supplied with hydraulic shock absorbers.



Options

Description	Symbol	Suffix
Shock absorbers (from Ø 15)		D

The options, when this is possible, can be combined with each other. For options matching and code key, see the tables below.

Options matching

Series	Bore	Model	Standard options matching
			D (Ø15+63)
ARC	Ø 10 ÷ 63	Standard	●
ARP	Ø 15 ÷ 32	Standard	●

Key

● allowed matching; - not allowed matching

Code key

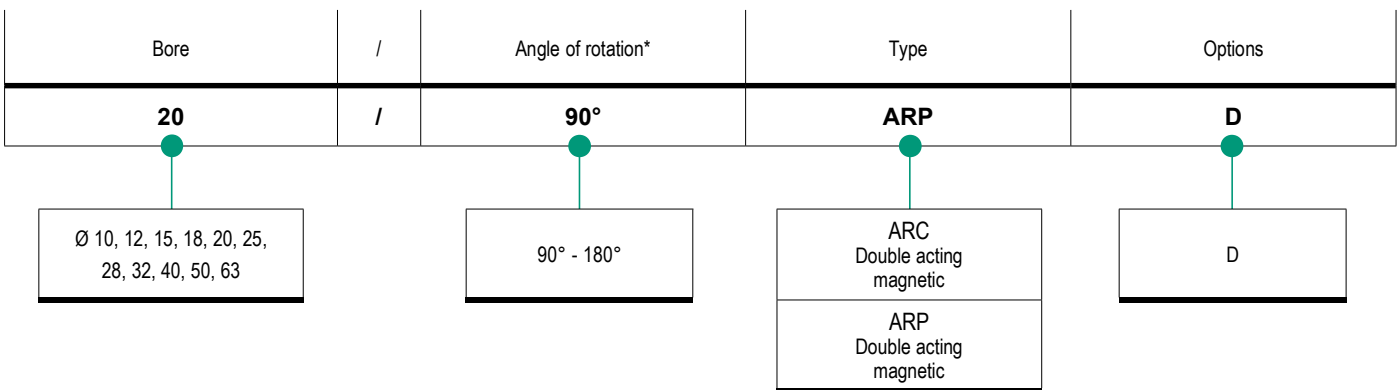

How to order

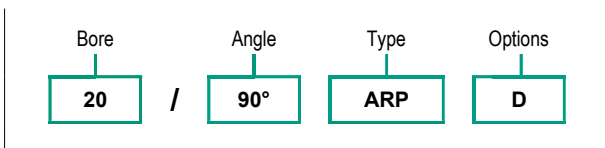

Notes

*Only for type ARP
For further information on options and their matching, see tables above.

Standard materials

Type: **ARC**

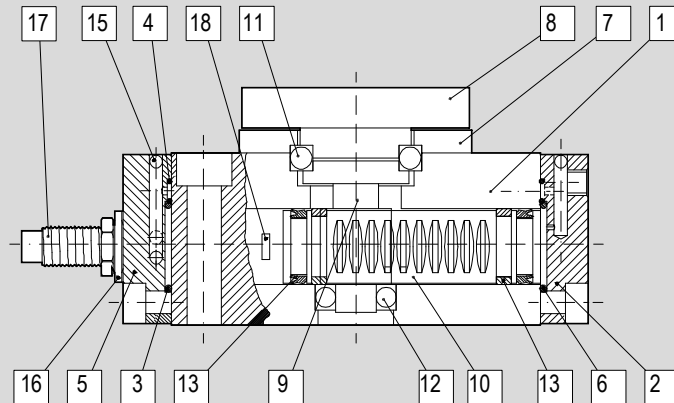

Position	Description	Materials
1	Body	Anodised aluminium
2	Front head	Anodised aluminium
3	O-ring	NBR
4	O-ring	NBR
5	Rear head	Anodised aluminium
6	O-ring	NBR
7	Bearing covers	Anodised aluminium
8	Rotating plate	Anodised aluminium
9	Rod	Hardened steel
10	Rack	Stainless Steel
11	Spherical bearing	Steel
12	Spherical bearing	Steel
13	Piston seal	NBR
14	Guide ring	Plastic material
15	Ball	Steel alloy
16	Stopper seal	NBR
17	Mechanical stopper	Steel alloy
18	Magnet	Magnetic metal

Standard materials

Type: **ARP**

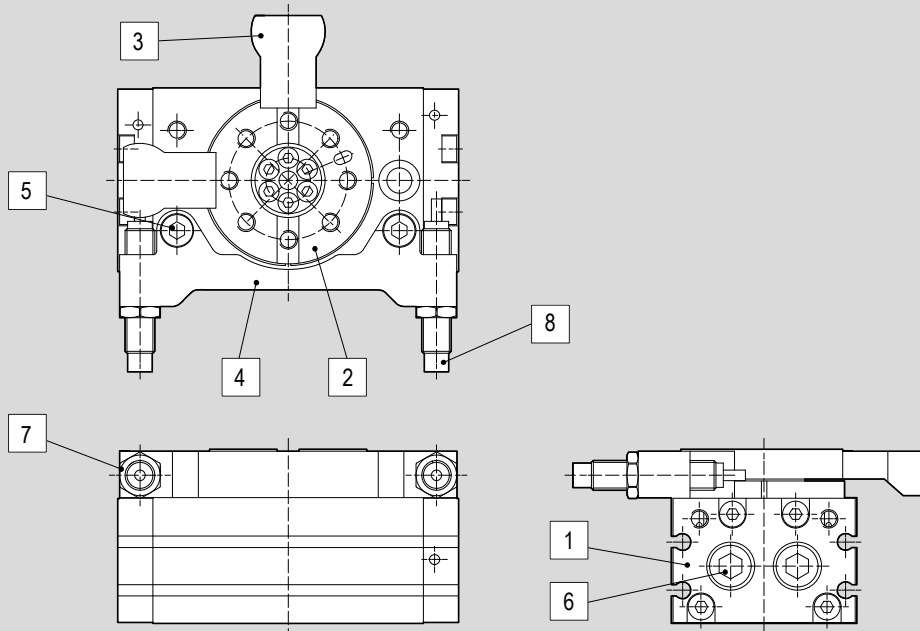

1 - CYLINDERS

Position	Description	Materials
1	Heads	Anodised aluminium
2	Rotary plate	Anodised aluminium
3	Spacer	Steel
4	Base	Anodised aluminium
5	Hexagonal nut	Anodised aluminium
6	Head nut	Steel
7	Hexagonal nut	Steel
8	Shock absorber	See page 1.105.4

Accessories

1 - CYLINDERS

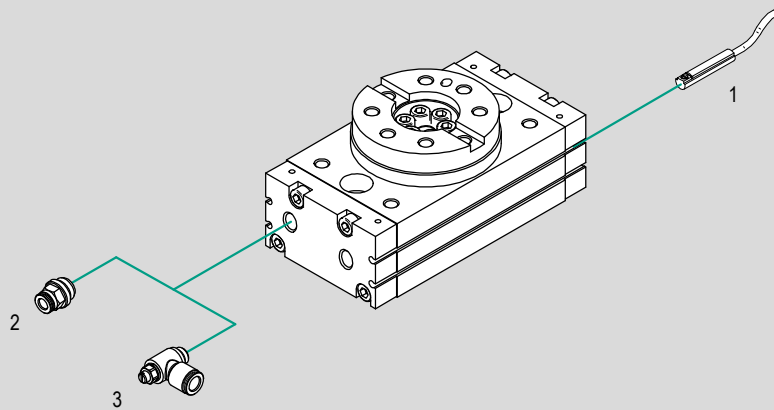

N.	Cylinder bore	Item	Description	Compliance	Matching		Code page	Data sheet page
					ARC	ARP		
1	Ø 10 ÷ 63	ASC..	Magnetic reed switch C groove	-	●	●	1.52.90	1.110.30
2	Ø 10 ÷ 63	R..	Push-in fittings	-	●	●	4.2.1	
3	Ø 10 ÷ 63	V..C	Flow controls, for cylinders	-	●	●	4.94.1	

Key

● allowed matching; - not allowed matching

Main features

10 ÷ 63

Bores Ø



Double acting
Magnetic

ARC

Type



Technical data

Bore Ø mm	10	12	15	18	20	25	28	32	40	50	63
Code	075581	075582	073063	073064	073065	073066	075583	075584	075585	075586	075587
Fluid	Filtered compressed air with or without lubrication. Lubrication, if started, must be continued.										
Pressure range	1,5 ÷ 7 bar										
Temperature range	0°C ÷ +50°C										
Angle of rotation	180°										
Adjustable angle	0° ÷ 190°										
Rotary momentum (Nm) at 6 bar	0,3	0,6	1,5	2,2	3,2	5,5	7,5	9,8	19	31	45
Maximum Absorbing Capacity* (Nm)	-		3	6		20	59		147		
Ports	M3	M5			1/8"						
Weight (g)	150	250	530	990	1.290	2.100	2.890	4.100	7.650	8.960	11.170

*Of shock absorber

Direction and rotation angle

Type: ARC

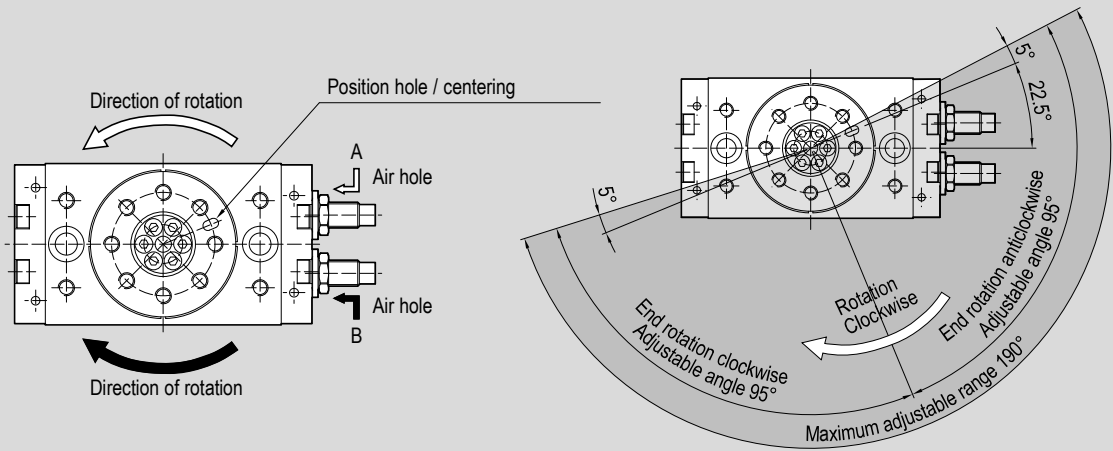

Rotation angles

Type: ARC

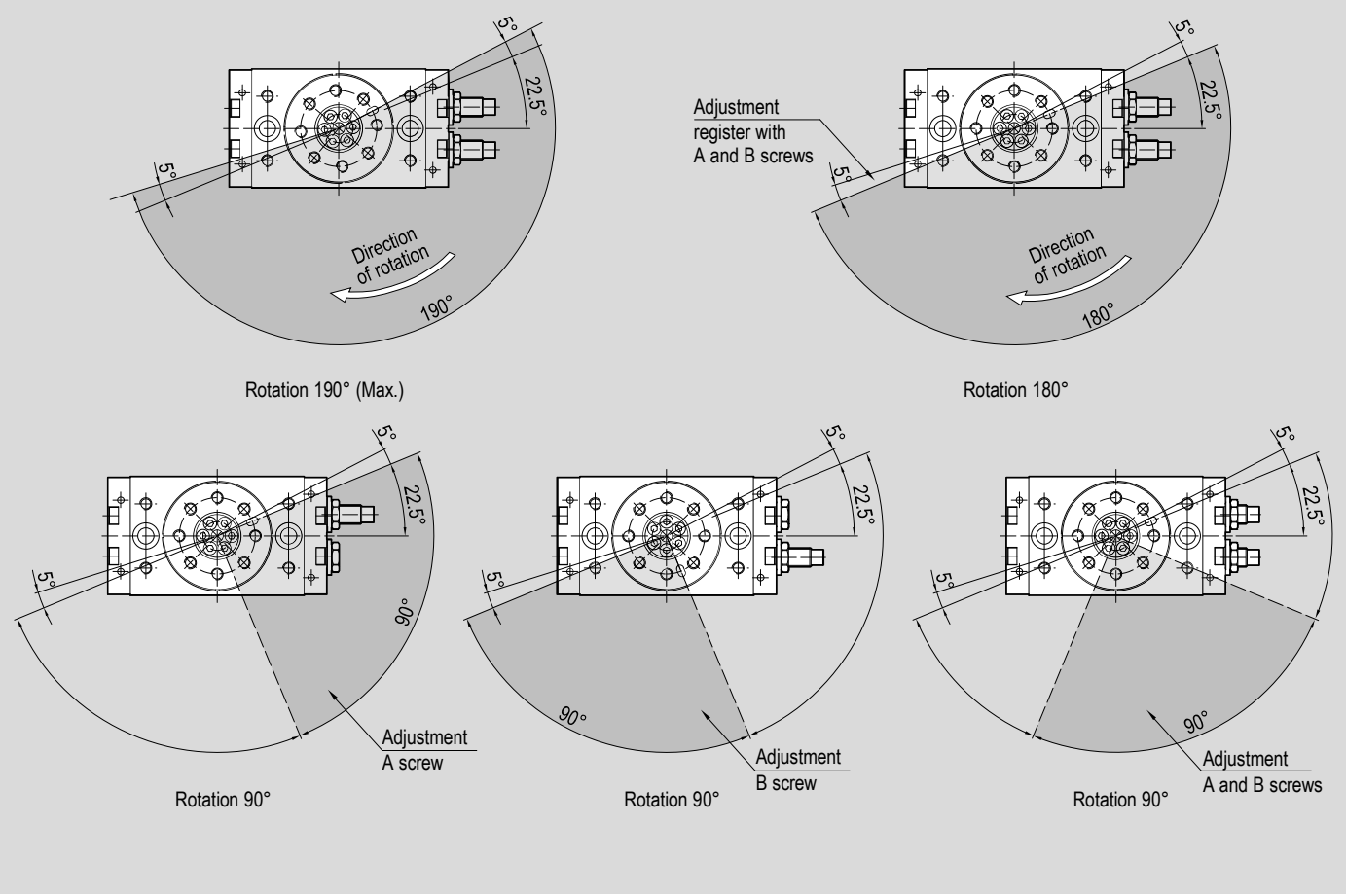

Output torque table

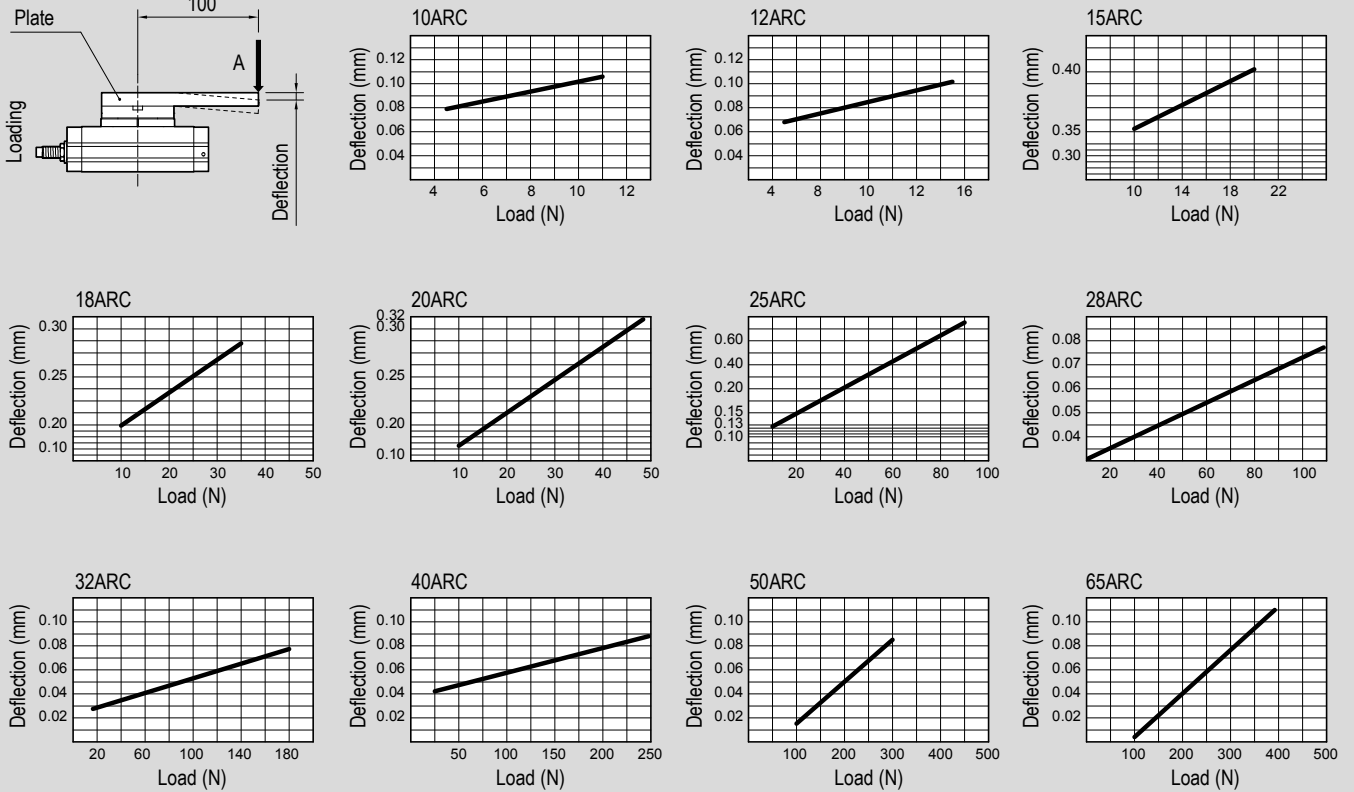
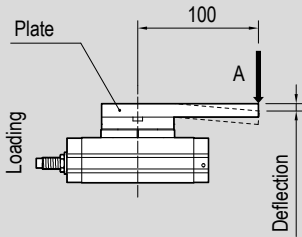

1 - CYLINDERS

Possible loads

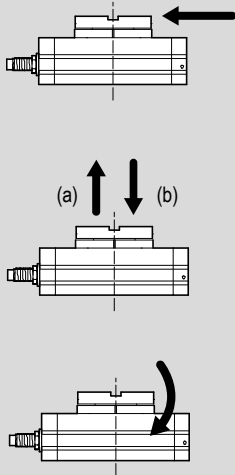

Type of loads	Actuator bore Ø											
	10	12	15	18	20	25	28	32	40	50	63	
Side (N)	33	54	70	140	185	300	333	390	543	850	1200	
Top (N)	(a)	48	71	78	130	188	285	296	493	740	950	1400
	(b)	48	71	74	130	358	442	476	706	1009	1500	2100
Torque momentum (Nm)	1,1	1,5	2	3,5	4,8	9	12	18	25	30	38	

Standard dimensions

Type: ARC
Ø 10

1 - CYLINDERS

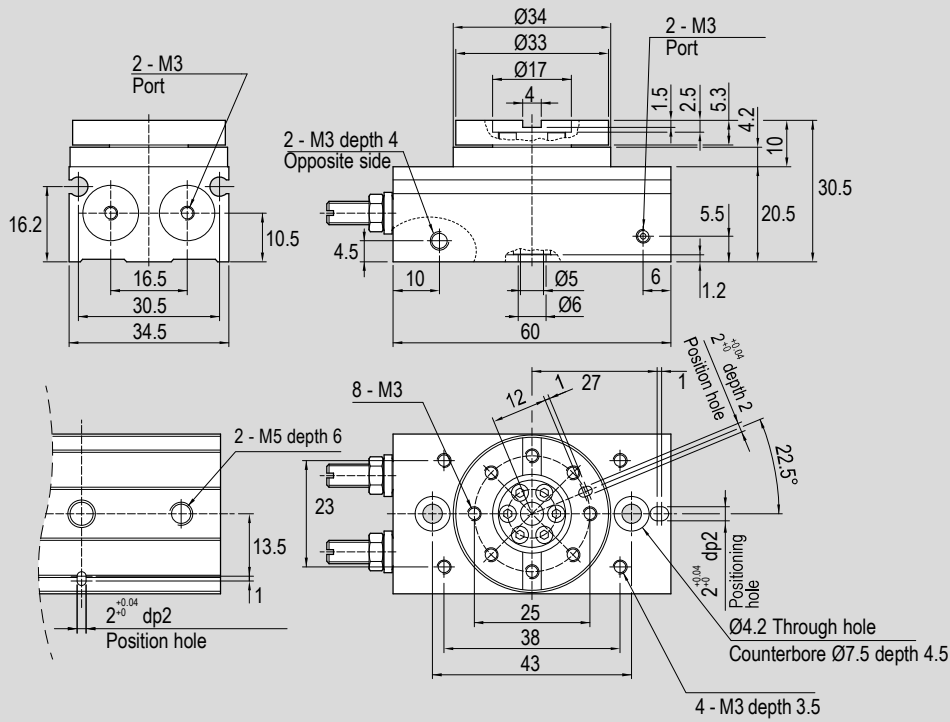

Type: ARC
Ø 12

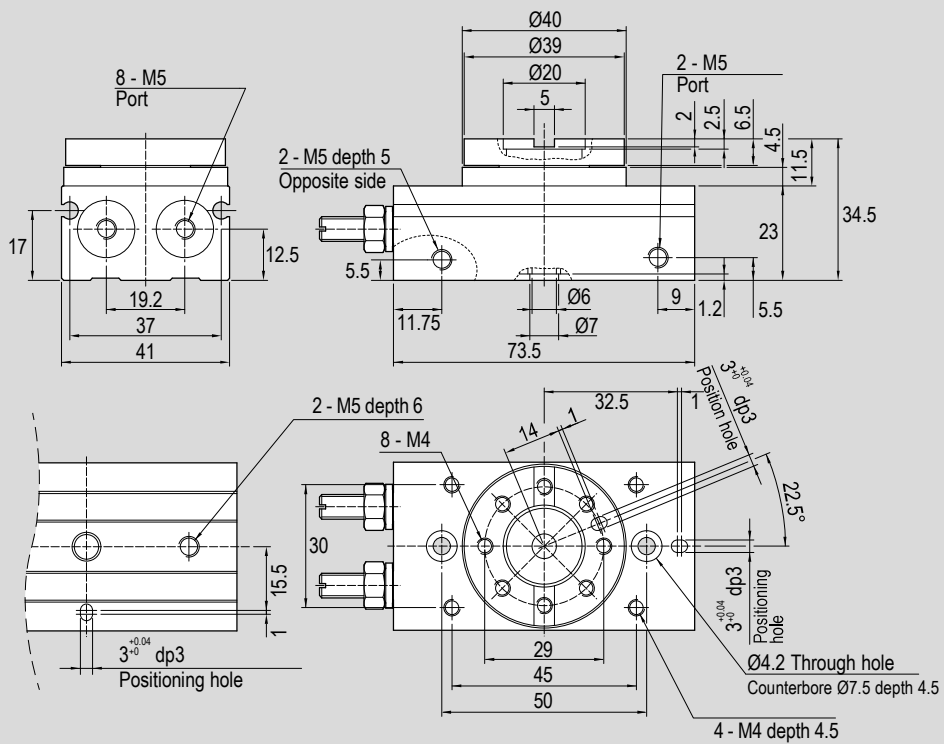

Standard dimensions

Type: ARC
Ø 15

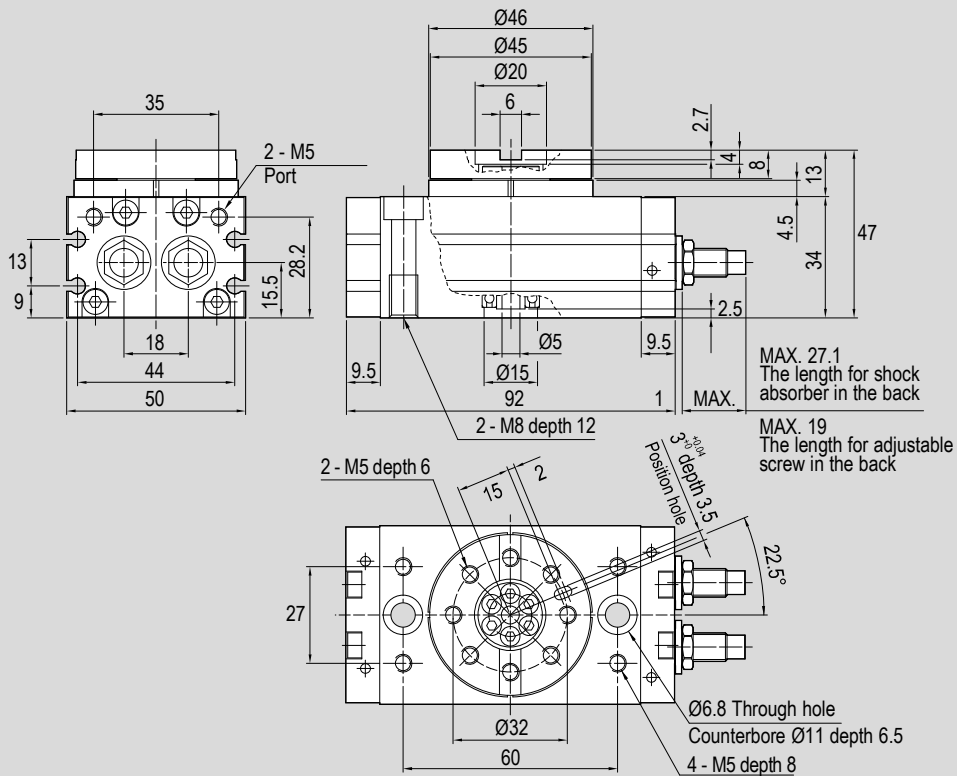

1 - CYLINDERS

Type: ARC
Ø 18

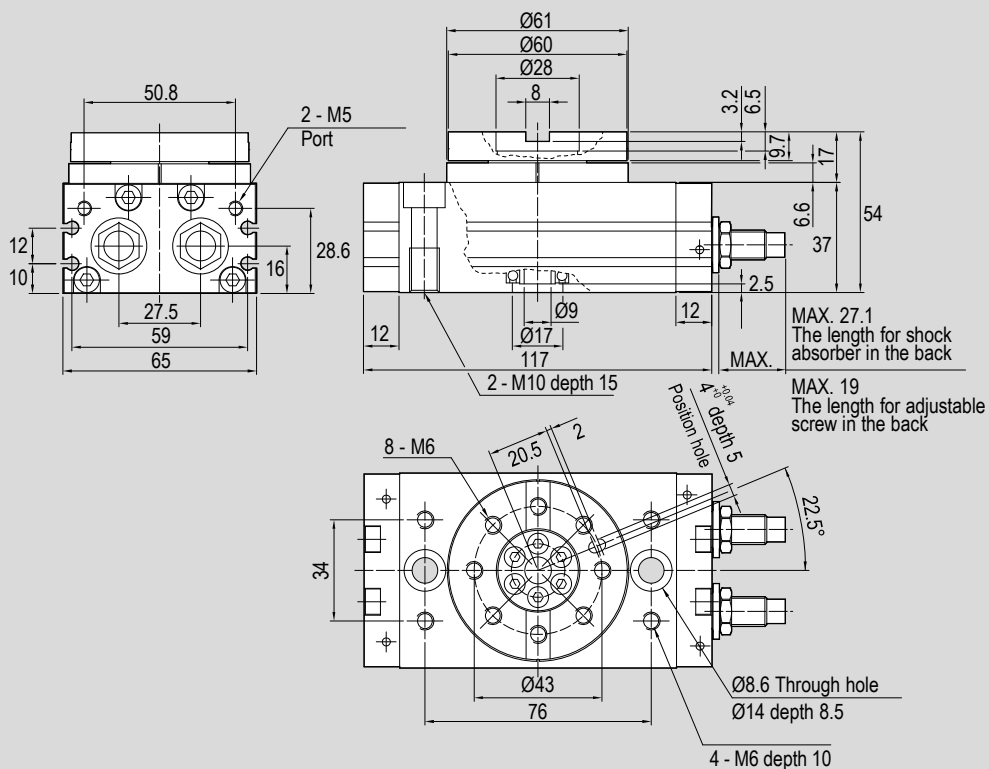

Standard dimensions

1 - CYLINDERS

Type: ARC
Ø 20

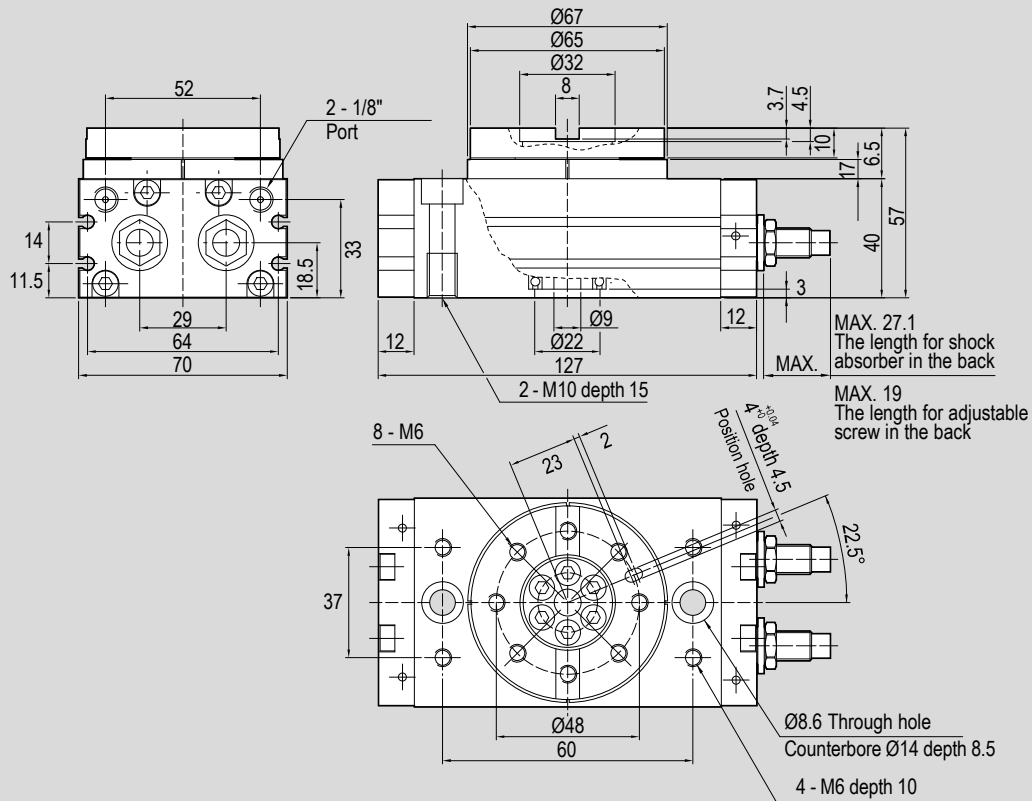

Type: ARC
Ø 25

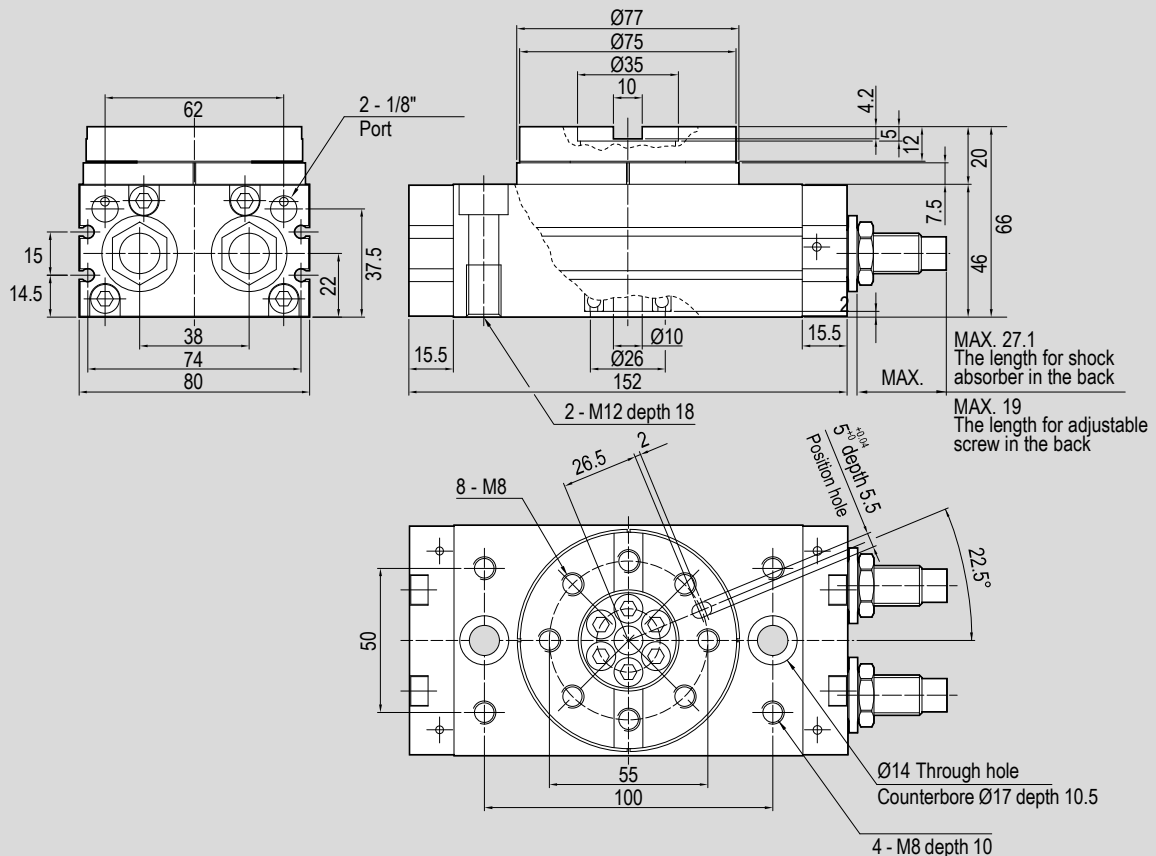

Standard dimensions

Type: ARC
Ø 28

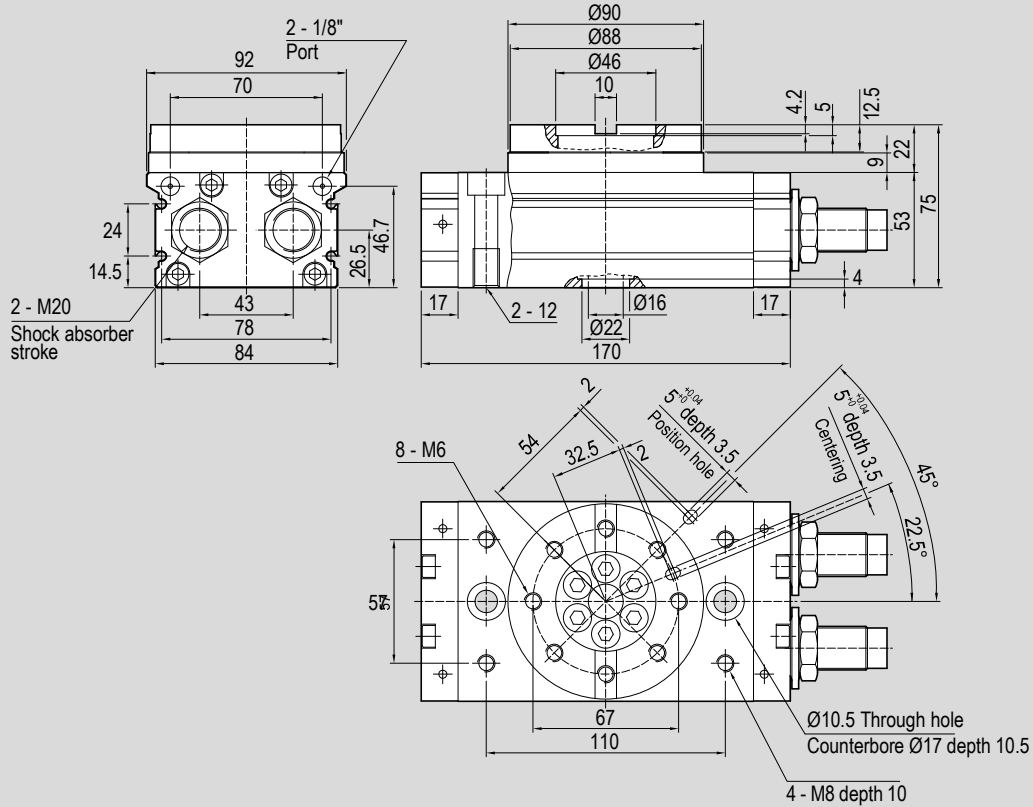

1 - CYLINDERS

Type: ARC
Ø 32

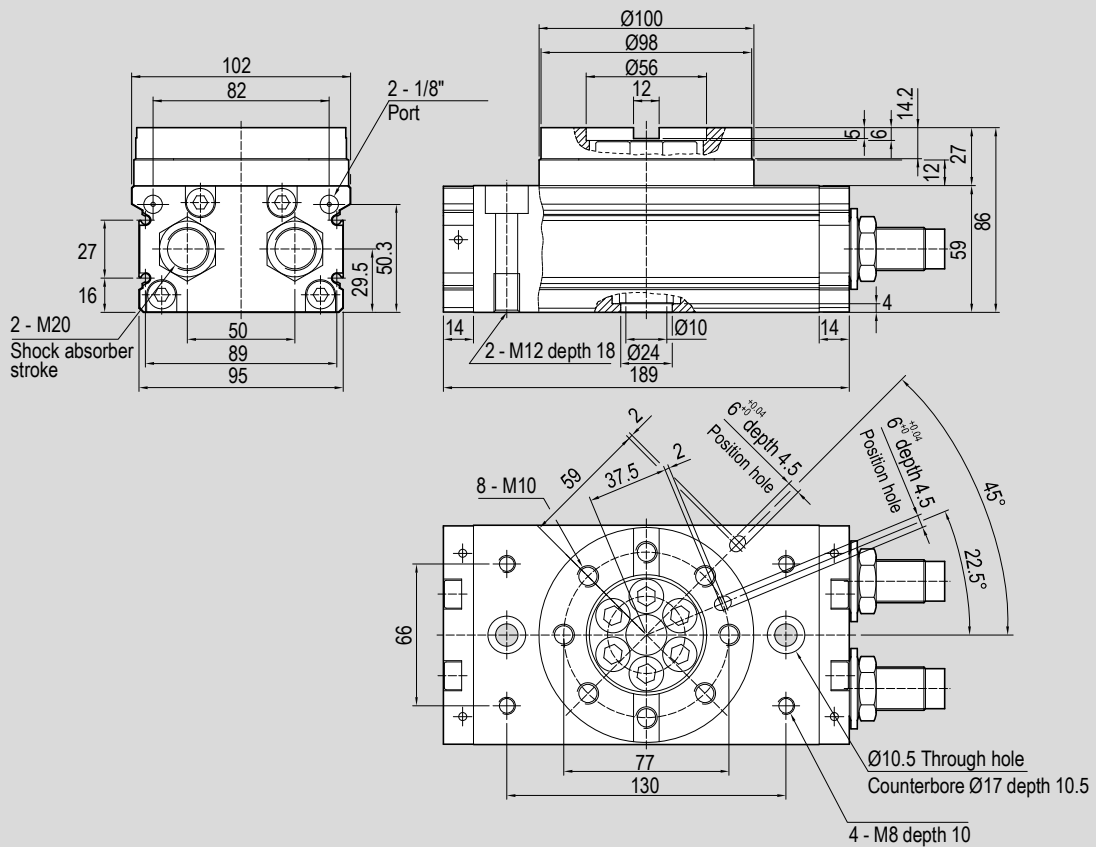

Standard dimensions

1 - CYLINDERS

Type: ARC
Ø 40

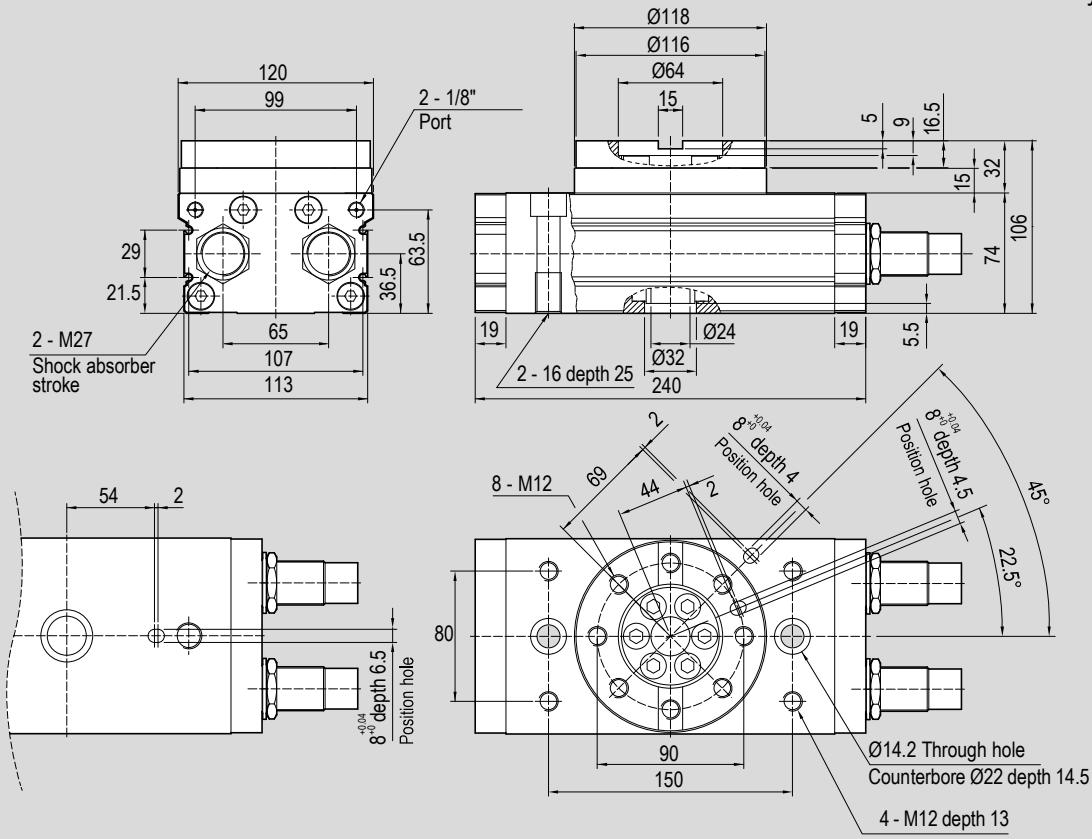

Type: ARC
Ø 50

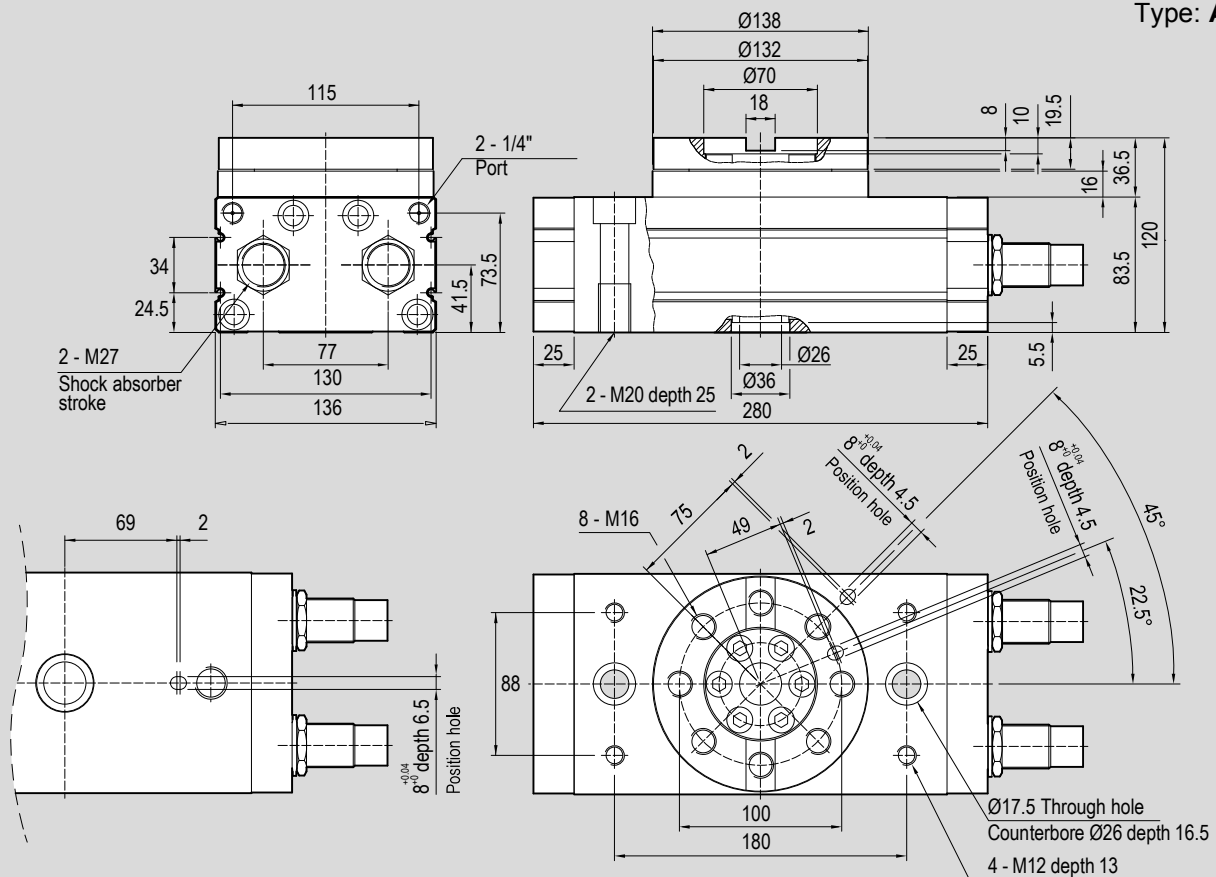

Standard dimensions

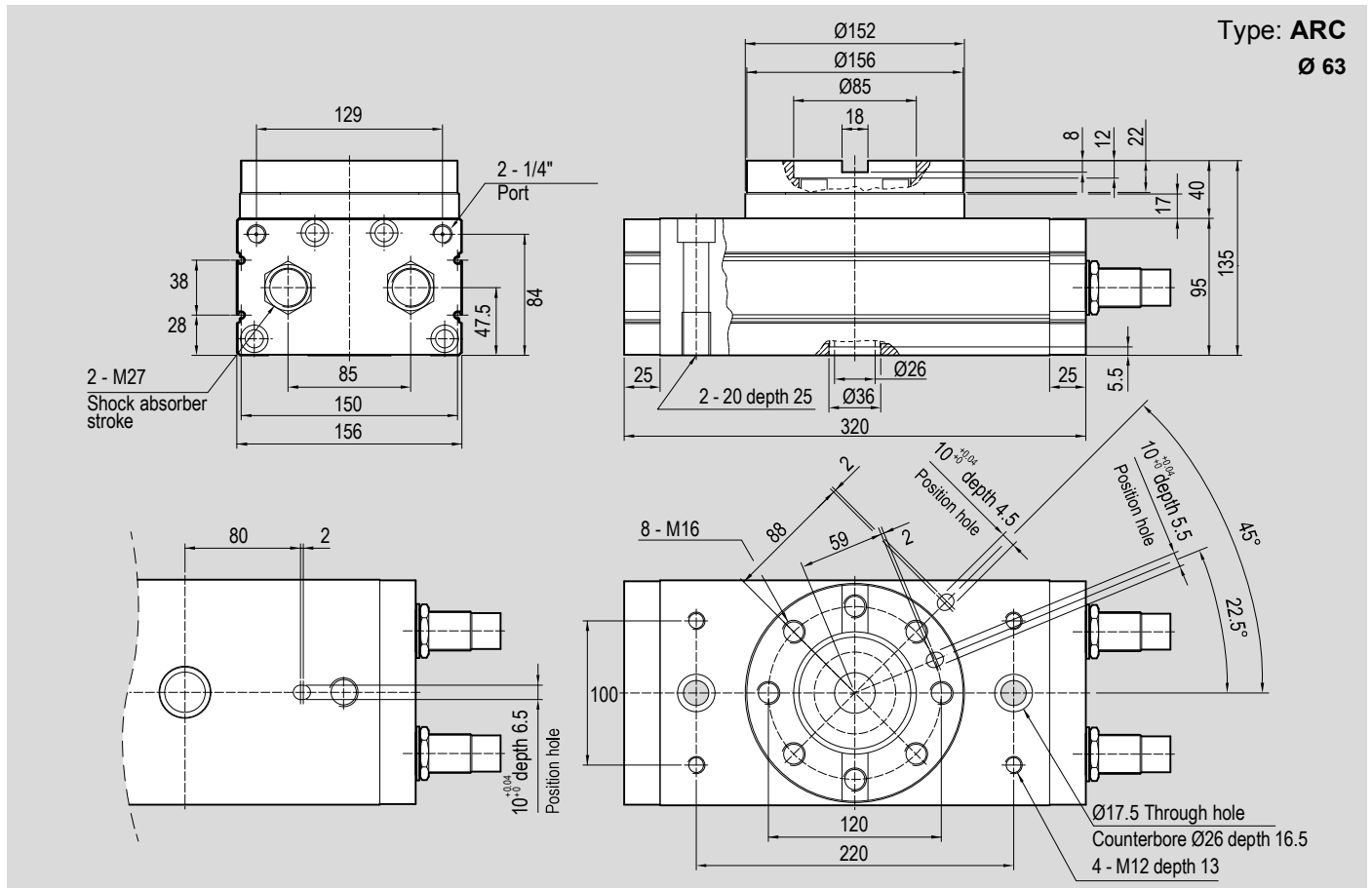

Main features

15 ÷ 32

Bores Ø



Double acting
Magnetic

ARP

Type



Technical data

Bore Ø mm	15		18		20		25		28		32	
Code	073071	073079	073072	073080	073073	073081	073074	073082	075588	075590	075589	075591
Fluid	Filtered compressed air with or without lubrication. Lubrication, if started, must be continued.											
Pressure range	1,5 ÷ 7 bar											
Temperature range	0°C ÷ +50°C											
Angle of rotation	90°	180°	90°	180°	90°	180°	90°	180°	90°	180°	90°	180°
Adjustable angle	10°											
Rotary momentum (Nm) at 6 bar	1,5		2,2		3,2		5,5		7,5		9,8	
Maximum Absorbing Capacity* (Nm)	3		6				20				59	
Ports	M5					1/8"						
Weight (g)	630	600	1200	1140	1520	1450	2480	2370	3390	3210	4700	4500

*Of hydraulic shock absorber

Direction and rotation angle

Type: ARP

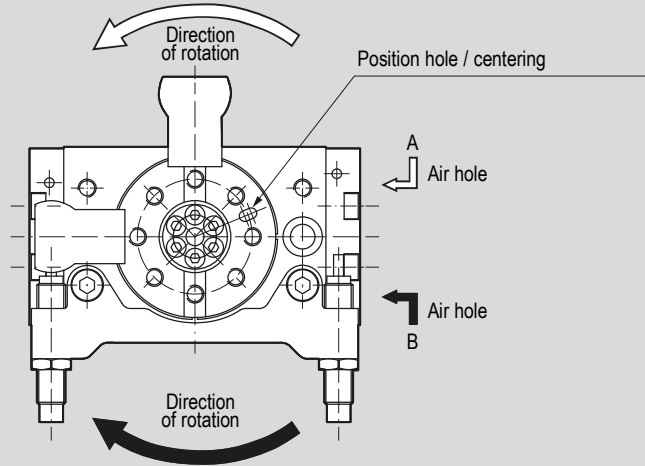

1 - CYLINDERS

Rotation angles

Type: ARP

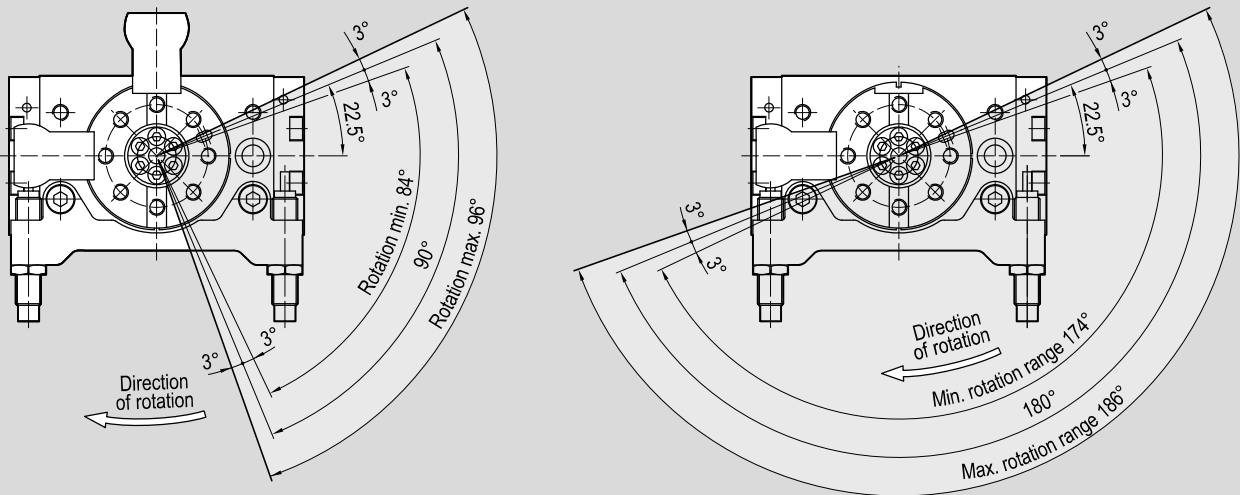

Standard dimensions

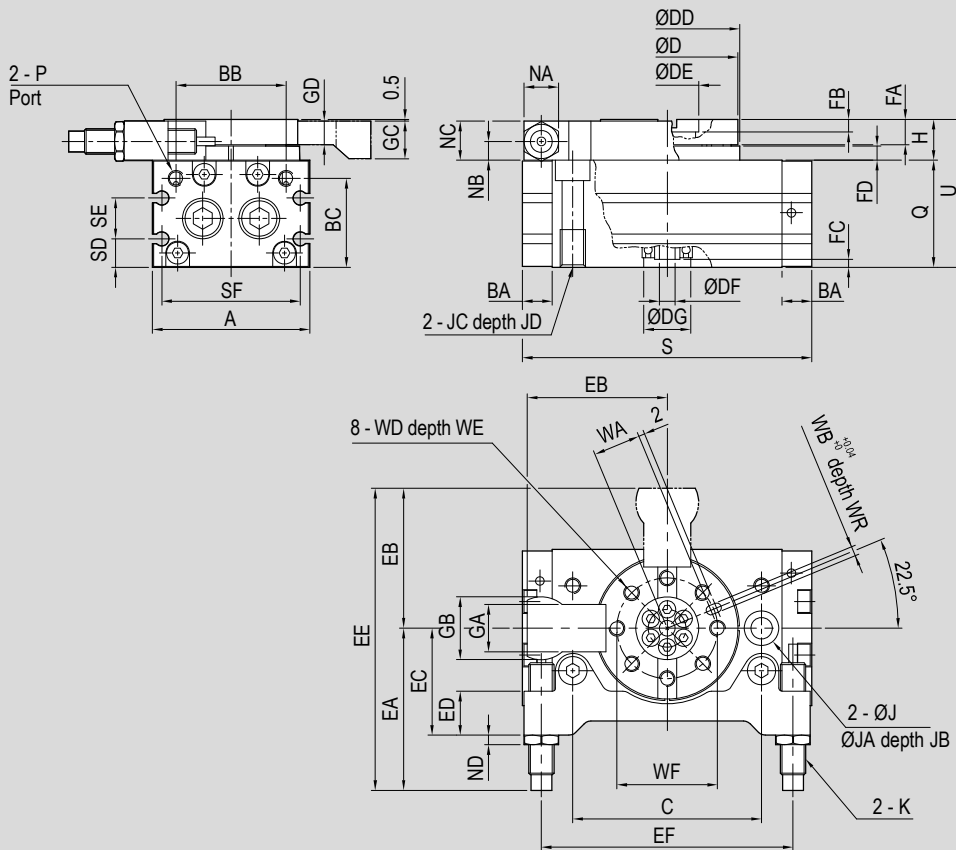

Type: ARP



Ø (mm)	A	BA	BB	BC	C	D	DD	DE	DF	DG	EA	EB	EC	ED	EE	EF	FA	FB	FC	FD	GA	GB	GC	GD	H
15	50	9,5	35	28,2	60	45	46	20	5	15	51,6	44,5	34	14	96,1	80	8	4	2,5	4,5	15	20	12	7,5	13
18	65	12	50,8	28,6	76	60	61	28	9	17	56	57	43	18	113	101	9,7	6,5	2,5	6,6	19	25	15	9,2	17
20	70	12	52	33	84	65	67	32	9	22	59	62	46	18	121	110	10	4,5	3	6,5	20	28	16	9,5	17
25	80	15,5	62	37,5	100	75	77	35	10	26	85	73	55	20	158	131	12	5	2	7,5	25	35	18	11,5	20
28	92	17	70	46,7	110	88	90	46	16	22	86	81	55,5	35	167	141	12,5	5	4	9	28	38	19,5	11,5	22
32	102	14	82	50,3	130	98	100	56	19	24	94	92,5	60	35	186,5	163	14,5	6	4	12	33	42	24,5	13,5	27

Ø (mm)	J	JA	JB	JC	JD	K	NA	NB	NC	ND	P	Q	S	SD	SE	SF	U	WA	WB	WR	WD	WE	WF
15	6,8	11	6,5	M8x1,25	12	M8x1	11	6	12,5	3	M5x0,8	34	92	9	13	44	47	15	3	3,5	M5x0,8	8	32
18	8,6	14	8,5	M10x1,5	15	M10x1	12,7	7,5	16,5	3	M5x0,8	37	117	10	12	59	54	20,5	4	5	M6x1	10	43
20	8,6	14	8,5	M10x1,5	15	M10x1	12,7	8,5	16,5	3	RC 1/8	40	127	11,5	14	64	57	23	4	4,5	M6x1	10	48
25	10,5	17	10,5	M12x1,75	18	M14x1,5	19	8,5	19,5	5	RC 1/8	46	152	14,5	15	74	66	26,5	5	5,5	M8x1,25	12	55
28	10,5	17	10,5	M12x1,75	18	M14x1,5	19	10	21,5	5	RC 1/8	53	170	14,5	24	78	75	32,5	5	5,5	M8x1,25	12,5	67
32	10,5	17	10,5	M12x1,75	18	M20x1,5	26	11,5	26	7	RC 1/8	59	189	16	27	89	86	37,5	6	6,5	M10x1,5	14,5	77

Magnetic reed switch C groove ASC..

	For cylinder Ø mm	Code	Item	Cylinder matching
	10 ÷ 63	070248 	ASC1C525	ARC ARP
		070249	ASC7N2M8	
		070382	ASC7M2M8	

CARTRIDGE

Cylinders



Find out our
key products



Solution for most applications



Easy and intuitive choice



Excellent value for money



Wide availability



Fast delivery



Features and certifications

Series of cartridge cylinders, available in bores from Ø 6 to 16, single acting, with threaded body allowing a further adjustment of the end stroke position.
 Seal kit not available.
 Supplied as standard in compliance with Reach and RoHS directives.



Type MCF Ø 6 ÷ 16

from page 1.55.20



Cartridge cylinders available in bores from Ø 6 to 16, single acting, with threaded body (allowing a further adjustment of the end stroke position) and threaded rod.

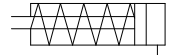

Type MCN Ø 6 ÷ 16

from page 1.55.20



Cartridge cylinders available in bores from Ø 6 to 16, single acting, with threaded body (allowing a further adjustment of the end stroke position) and non-threaded rod.

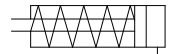

Options

Description	Symbol	Suffix
Special versions on request		/S

Code key

Bore	/	Stroke	Type	/	Special version
10	/	15	MCF	/	

Ø 6, 10, 16

5, 10, 15 mm

MCF
Single acting
With threaded rod

MCN
Single acting
With non-threaded rod

S

How to order

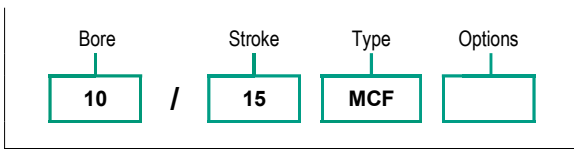

Notes

For further information on options and their matching, see tables above.

Standard materials

Type: **MCF, MCN**

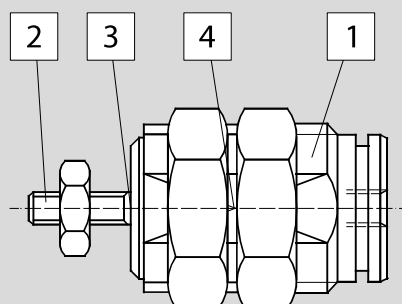

Position	Description	Materials
1	Body	Nickel-plated brass
2	Rod	Stainless Steel AISI 303
3	Seals	Polyurethane (PU)
4	Spring	Stainless Steel AISI 302

Main features

6 ÷ 16

Bores Ø

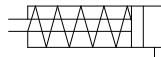

Single acting
With threaded rod

MCF

Type



6 ÷ 16

Bores Ø

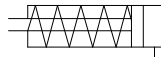

Single acting
With non-threaded rod

MCN

Type



Technical data

Bore Ø mm	6	10	16	
Fluid	Filtered compressed air with or without lubrication. Lubrication, if started, must be continued.			
Pressure range	2 ÷ 7 bar			
Temperature range	-20°C ÷ +80°C			
Strokes	5 ÷ 15 mm			
Port	M5			
Thrust force (Nm) at 6 bar	14	42	109	
Maximum side load (N)	0,10	0,15	0,20	
Traction force (N)	Stroke 5	1,4	3,9	9,9
	Stroke 10	2	3,4	8,7
	Stroke 15	1,5	2,9	7,4

Standard strokes

Stroke mm	MCF Bore Ø mm		
	6	10	16
5			
10			
15			

Stroke mm	MCN Bore Ø mm		
	6	10	16
5			
10			
15			

Key
 Standard stroke

Standard dimensions

Type: **MCF**

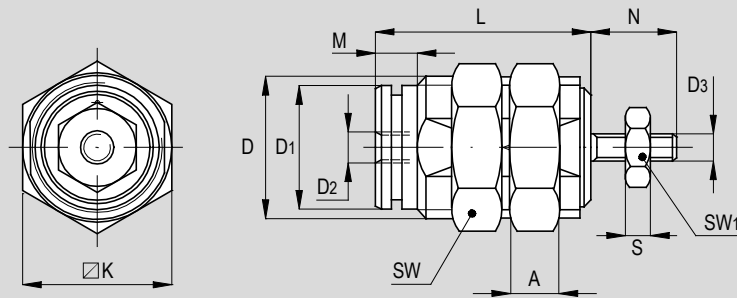

Type: **MCN**

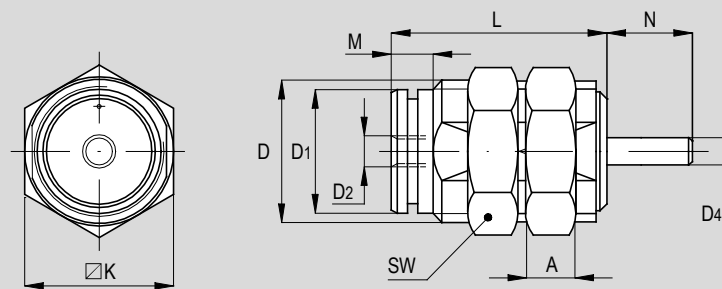

\emptyset (mm)	D	D1	D2	D3	D4	$\square K$	M	L			N	A	S	SW	SW1
								Stroke 5	Stroke 10	Stroke 15					
6	M10x1	8,5	M5	M3	3	9	5	19,5	26,5	33,5	8	3	2,4	14	5,5
10	M15x1,5	12	M5	M4	4	19	7	23	29,5	36,5	10,5	4	2	19	7
16	M22x1,5	19	M5	M5	5	20	6	27	32	37	13	5	4	27	8

HAND Grips

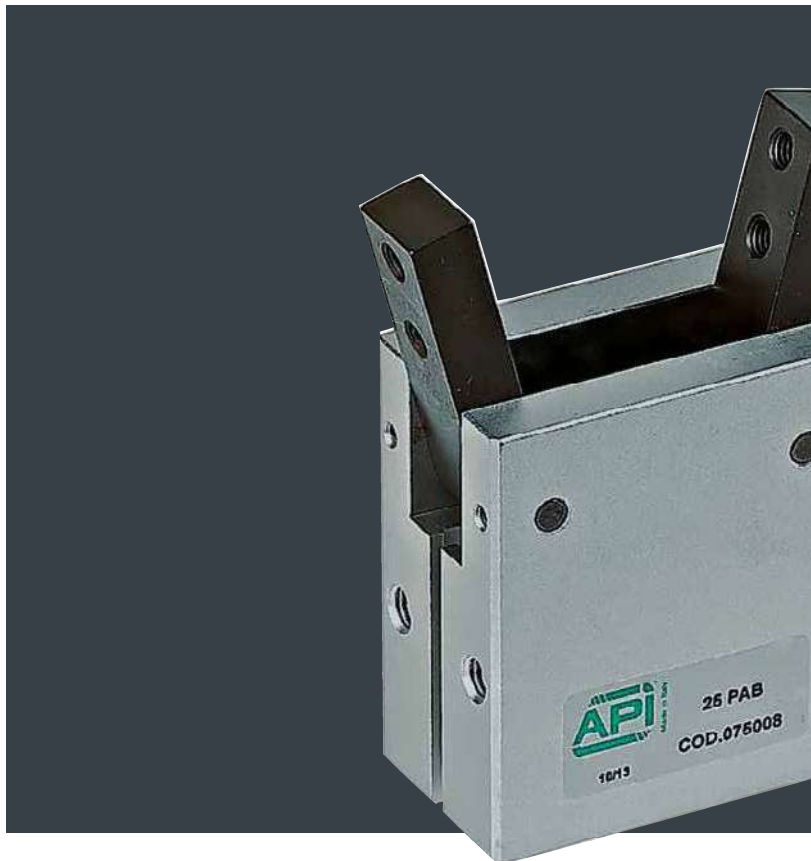

Find out our
key products



Solution for most applications



Easy and intuitive choice



Excellent value for money



Wide availability



Fast delivery



Features and certifications

Series of pneumatic hand grips available in bores from Ø 6 to 100, double acting, magnetic. Different type and configurations available. Supplied as standard in compliance with Reach and RoHS directives.



Type PAB Ø 10 ÷ 32

from page 1.60.20



Angular hand grips available in bores from Ø 10 to 32, double acting (on request also single acting), magnetic, with grooves allowing the mounting of magnetic reed switches directly.

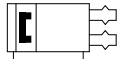

Type PAC Ø 12 ÷ 32

from page 1.60.30



180° angular hand grips available in bores from Ø 12 to 32, double acting, magnetic, with grooves allowing the mounting of magnetic reed switches directly.

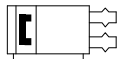

Type PPB Ø 10 ÷ 32

from page 1.60.40



Parallel hand grips available in bores from Ø 10 to 32, double acting, magnetic, with grooves allowing the mounting of magnetic reed switches directly.

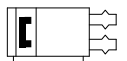

Type PPC Ø 6 ÷ 40

from page 1.60.50



Guided parallel hand grips available in bores from Ø 6 to 40, double acting (on request also single acting), magnetic, with grooves allowing the mounting of magnetic reed switches directly.

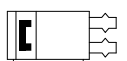

Type PPD Ø 10 ÷ 40

from page 1.60.60



Parallel hand grips with long stroke available in bores from Ø 10 to 40, double acting, magnetic, with grooves allowing the mounting of magnetic reed switches directly.

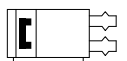

Type PPE Ø 16 ÷ 100

from page 1.60.70



Hand grips with 3 fingers available in bores from Ø 16 to 100, double acting, magnetic, with grooves allowing the mounting of magnetic reed switches directly.

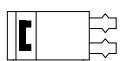

Options		
Description	Symbol	Suffix
Single acting version normally open (only for type PAB and PPC)		/SE
Side lever mounting (only for type PPD)		B
Special versions on request		/S

For code key see the table below.

Code key

Bore	Type	/	Options
20	PAB	/	SE
PAB Ø 10, 16, 20, 25, 32	PAB Double acting Magnetic Angular		SE*
PAC Ø 12, 16, 20, 25, 32	PAC Double acting Magnetic Angular 180°		S
PPB Ø 10, 16, 20, 25, 32	PPB Double acting Magnetic Parallel		
PPC Ø 6, 10, 16, 20, 25, 32, 40	PPC Double acting Magnetic Guided parallel		
PPE Ø 16, 20, 25, 32, 40, 50, 63, 80, 100	PPE Double acting Magnetic 3 fingers		

*Only PAB - PAC type

Bore	/	Stroke	Type	Options
20	/	50	PPD	B
Ø 10, 16, 20, 25, 32, 40		20 ÷ 160 mm	PPD Double acting Magnetic Parallel long stroke	B
				/S

How to order

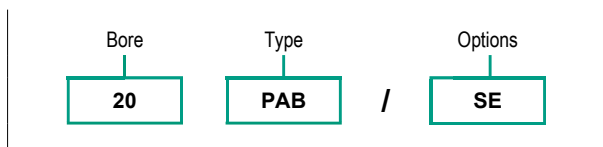

How to order

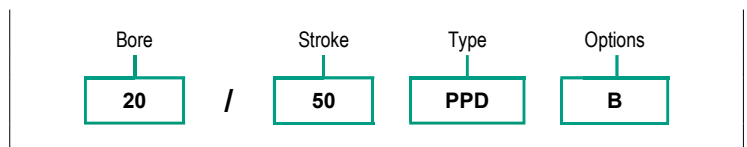

Notes

For further information on options see table above.

Standard materials

1 - CYLINDERS

Type: PAB

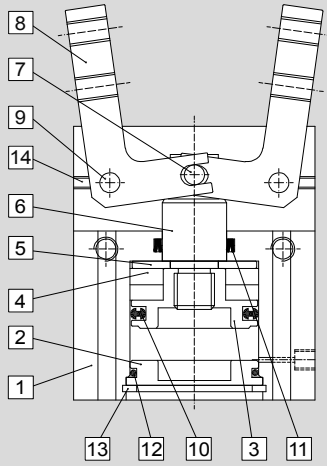

Type: PAC

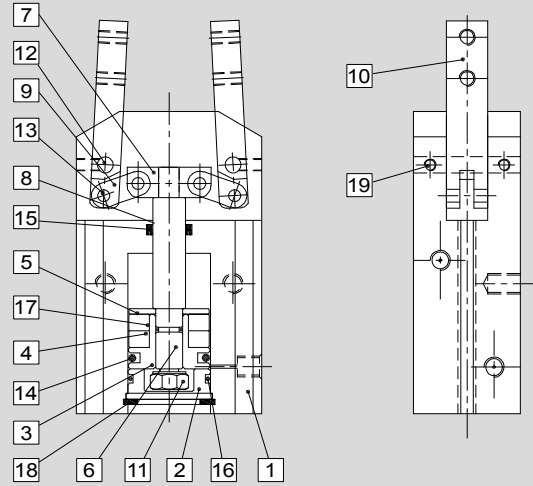

Position	Description	Materials
1	Body	Aluminium
2	End cover	Brass
3	Piston	Brass
4	Magnet	Plastic magnet
5	Spacer	Brass
6	Piston rod	Stainless Steel
7	Piston rod pin	Steel
8	Fingers	Steel alloy
9	Slide pin	Steel
10	Piston seal	NBR
11	Rod seal	NBR
12	End cover seal	NBR
13	Seeger	Steel
14	Hexagonal screw	Steel alloy

Position	Description	Materials
1	Body	Aluminium
2	End cover	Aluminium
3	Piston	Brass
4	Magnet	Plastic magnet
5	Spacer	Brass
6	Piston rod	Stainless Steel
7	End piston joint	Steel alloy
8	Piston rod pin	Steel
9	Actioning lever	Steel alloy
10	Fingers	Steel alloy
11	Nut	Steel
12	Slide pin	Steel
13	Action lever pin	Steel
14	Piston seal	NBR
15	Piston rod seal	NBR
16	End cover seal	NBR
17	Rod seal	NBR
18	Seeger	Spring steel
19	Hexagonal screw	Steel alloy

Standard materials

Type: PPB

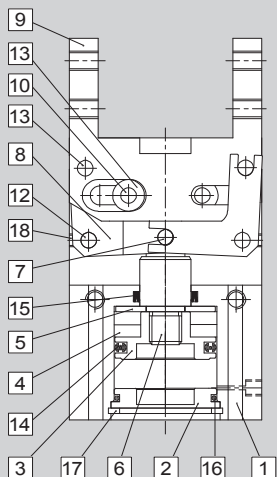

Type: PPC

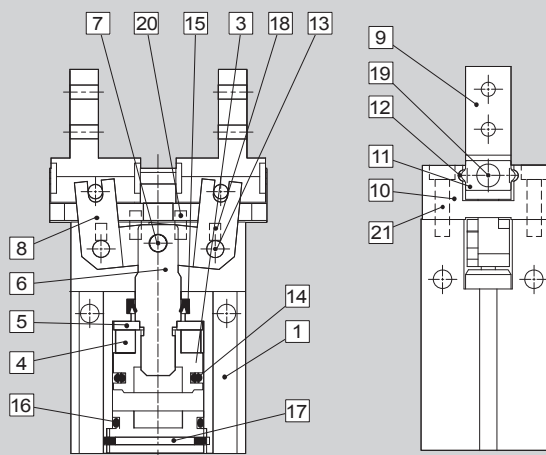

1 - CYLINDERS

Position	Description	Materials
1	Body	Aluminium
2	End cover	Brass
3	Piston	Brass
4	Magnet	Plastic magnet
5	Spacer	Brass
6	Piston rod	Stainless Steel
7	Piston rod pin	Steel
8	Actioning lever	Steel alloy
9	Fingers	Steel alloy
10	Slide guide pin	Steel
11	Slide pin	Steel
12	Action lever pin	Steel
13	Washer	Steel alloy
14	Piston seal	NBR
15	Piston rod seal	NBR
16	End cover seal	NBR
17	Seeger	Spring steel
18	Hexagonal screw	Steel alloy

Position	Description	Materials
1	Body	Aluminium alloy
2	End cover	Aluminium alloy
3	Piston	Copper
4	Magnet	Plastic magnet
5	Spacer	Copper
6	Piston rod	Stainless Steel
7	Pin	Steel
8	Actioning lever	Stainless Steel
9	Fingers	Stainless Steel
10	Fingers base	Stainless Steel
11	Ball stopper	Stainless Steel
12	Ball	Steel
13	Action lever pin	Steel
14	Piston seal	NBR
15	Rod seal	NBR
16	End cover seal	NBR
17	Snap ring	Steel alloy
18	Screw	Steel alloy
19	Screw	Steel alloy
20	Pin	Steel
21	Mounting screw	Steel alloy

Standard materials

1 - CYLINDERS

Type: PPD

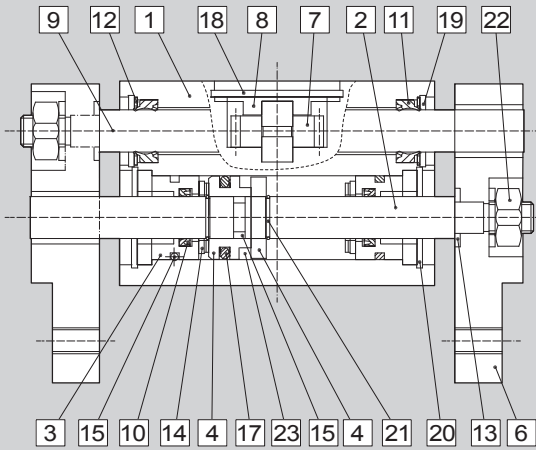

Type: PPE

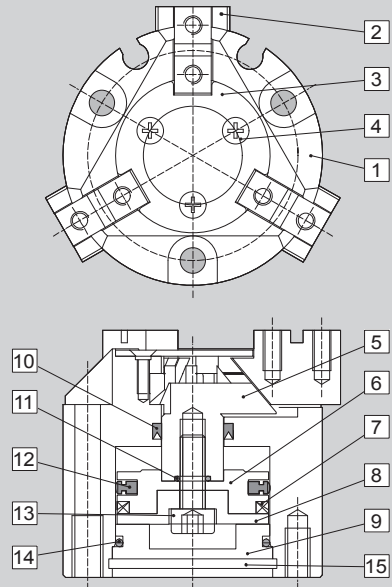

Position	Description	Materials
1	Body	Aluminium
2	Piston rod	Stainless Steel
3	End cover	Aluminium
4	Piston	Brass
5	Magnet holder	Brass
6	Fingers	Aluminium
7	Pinion	Carbon steel
8	Pinion cover	Iron
9	Rod guide	Stainless Steel
10	Piston rod seal	NBR
11	Rod guide seal	NBR
12	Seeger	Iron
13	Cushion spacer	Iron
14	Piston rod dampers	Polyurethane (PU)
15	End cover seal	NBR
16	Piston seal	NBR
17	Piston o-ring	NBR
18	Seeger	Spring steel
19	Seeger	Spring steel
20	Seeger	Spring steel
21	Seeger	Spring steel
22	Nut	Steel
23	Magnet	Plastic magnet

Position	Description	Materials
1	Body	Aluminium alloy
2	Fingers	Steel alloy
3	Spacer	Stainless Steel
4	Spacer screw	Steel alloy
5	Rod	Steel alloy
6	Piston	Aluminium alloy
7	Magnet	Plastic magnet
8	Magnet cover	Aluminium alloy
9	End cover	Aluminium alloy
10	Shaft seal	NBR
11	Shaft o-ring	NBR
12	Piston seal	NBR
13	Screw	Steel alloy
14	End cover o-ring	NBR
15	Seeger	Steel alloy

Accessories

1 - CYLINDERS

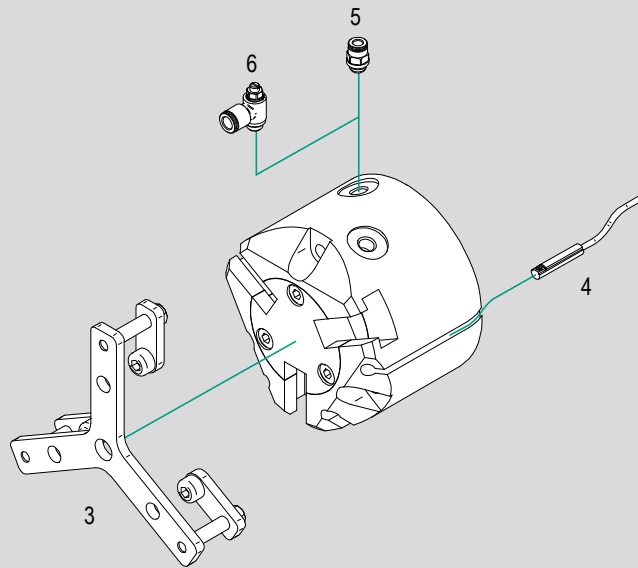
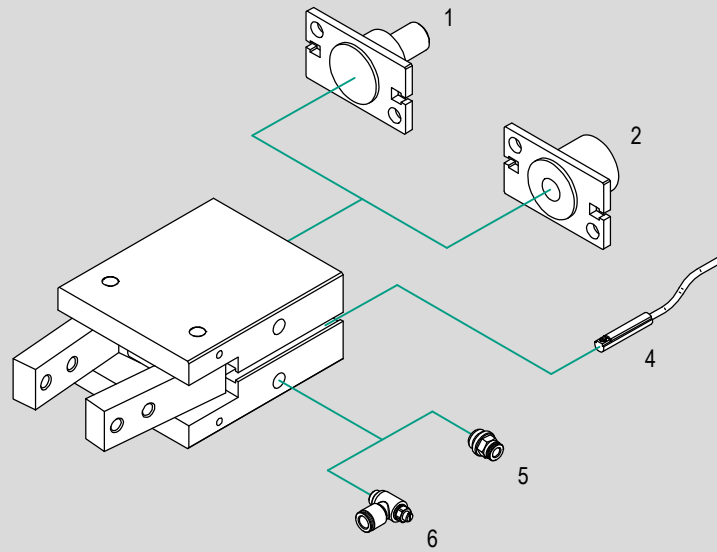

N.	Cylinder bore	Item	Description	Compliance	Matching						Code page	Data sheet page
					PAB	PAC	PPB	PPC	PPD	PPE		
1	Ø 10 ÷ 32	..PM	Male mounting	-	●	●	●	-	-	-	1.60.90	1.100.350
2	Ø 10 ÷ 32	..PF	Female mounting	-	●	●	●	-	-	-		1.100.351
3	Ø 25 ÷ 100	..PTD	Plate	-	-	-	-	-	-	●		1.110.30
4	Ø 6 ÷ 100	ASC..	Magnetic reed switch C groove	-	●	●	●	●	●	●	4.2.1	
5	Ø 6 ÷ 100	R..	Push-in fittings	-	●	●	●	●	●	●		
5	Ø 6 ÷ 100	V..C	Flow controls, for cylinders	-	●	●	●	●	●	●	4.94.1	

Key

● allowed matching; - not allowed matching

Main features

10 ÷ 32

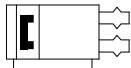

PAB

Bores Ø

Double acting
Magnetic
Angular

Type



Technical data

Bore Ø mm		10	16	20	25	32
Fluid	Compressed filtered air					
Lubrication	Piston	With or without lubrication				
	Lever	Lubrication required on sliding parts				
Pressure range	1,5 ÷ 7 bar					
Temperature range	0°C ÷ +60°C					
Lever open/close angle	-10° ÷ +30°					
Maximum operation frequency	80/min.					
Ports	M3	M5				
Maximum length of gripping point L	30 mm	40 mm	60 mm	70 mm	85 mm	
Theoretical gripping force M (Kgf·cm)	Closing	0,16 x P	0,80 x P	1,70 x P	3,40 x P	6,10 x P
	Opening	0,26 x P	1,10 x P	2,30 x P	4,30 x P	8,10 x P
Effective gripping force F (N)	F = M / L x 0,85					
Weight (g)	100	120	200	330	560	

Key

F = effective gripping force; **M** = theoretical gripping force; **L** = maximum length of gripping point; **P** = operating pressure;
See also table at page 1.60.21

Codes

Function	PAB Bore Ø mm				
	10	16	20	25	32
Double acting	075023	075004	075006	075008	075010
Single acting	075072	075073	075070	075071	170677

Gripping forces

Type: PAB

1 - CYLINDERS

Bore: Ø 10

Bore: Ø 16

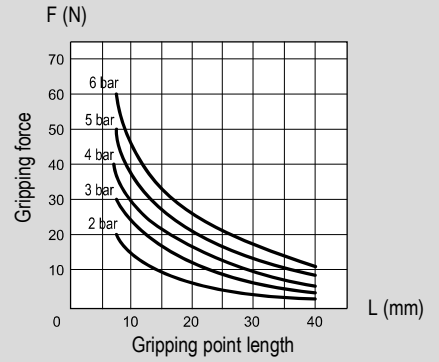
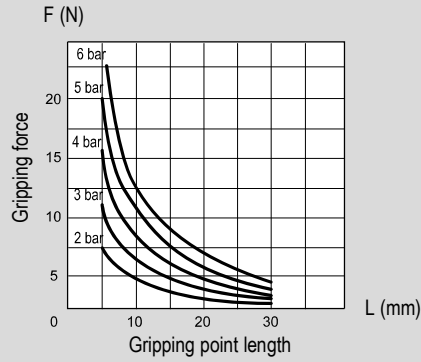
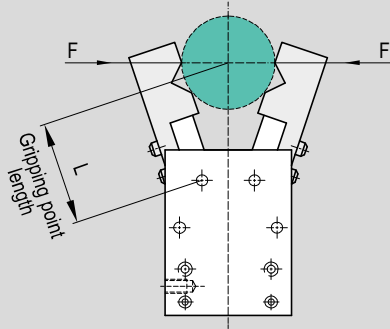

Bore: Ø 20

Bore: Ø 25

Bore: Ø 32

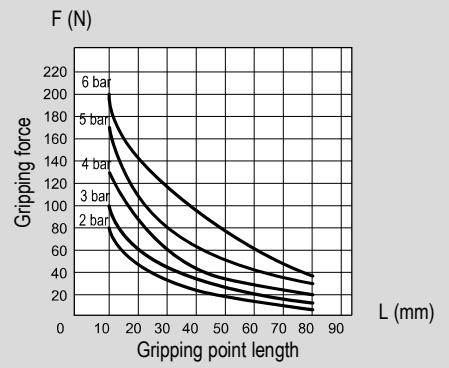
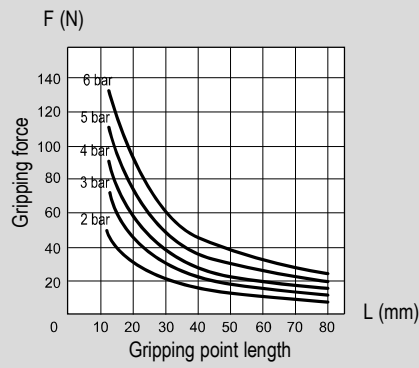
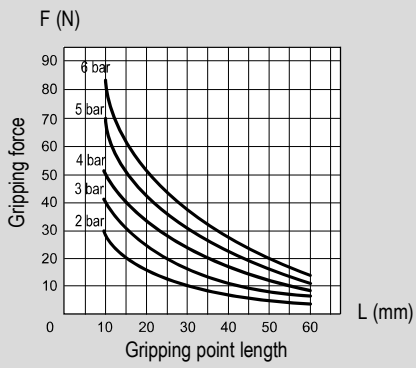

Standard dimensions

1 - CYLINDERS

Type: PAB
Ø 10

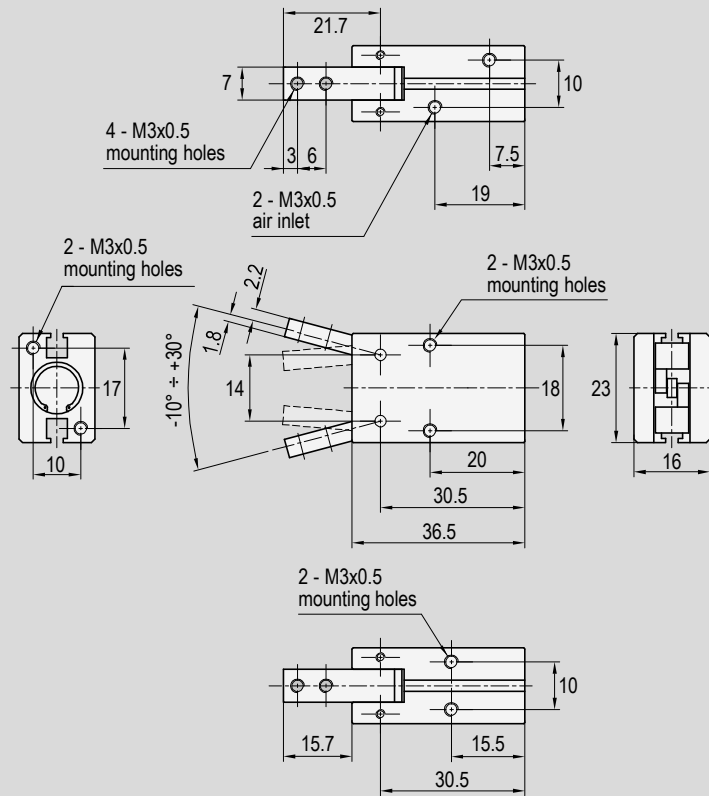

Type: PAB
Ø 16

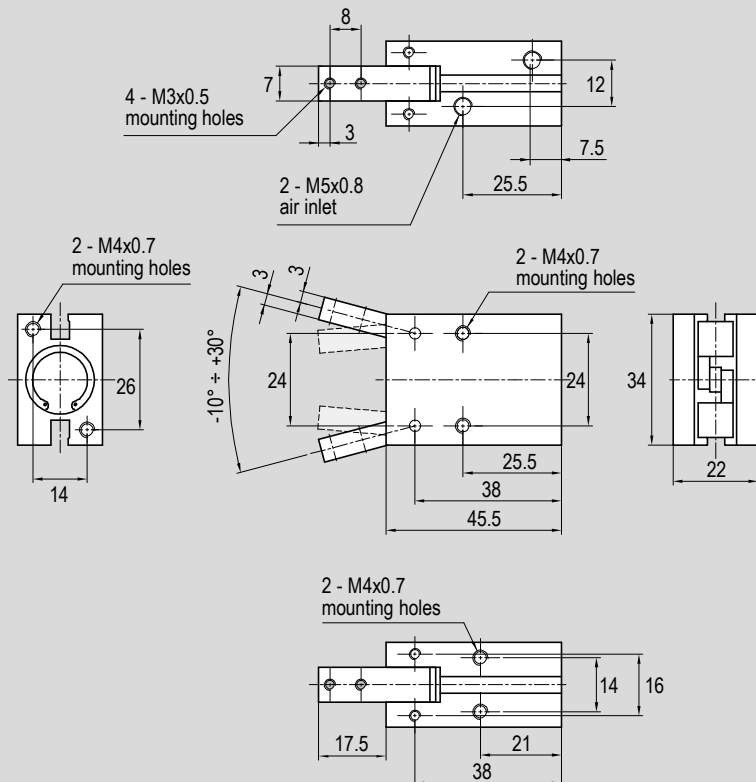

Standard dimensions

Type: PAB
Ø 20

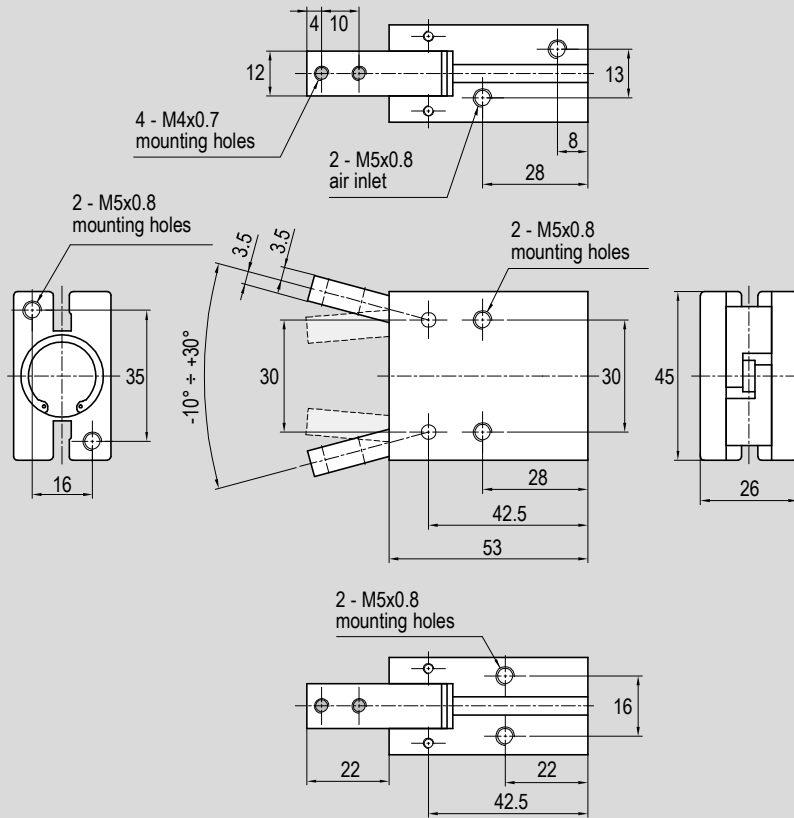

Type: PAB
Ø 25

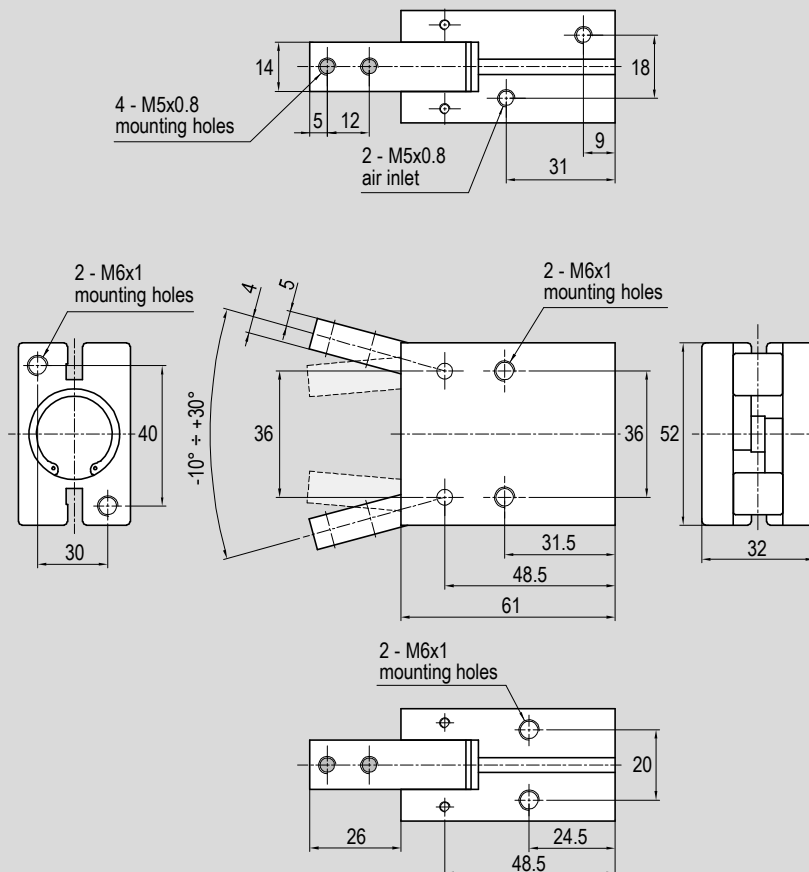

Standard dimensions

Type: **PAB**
Ø 32

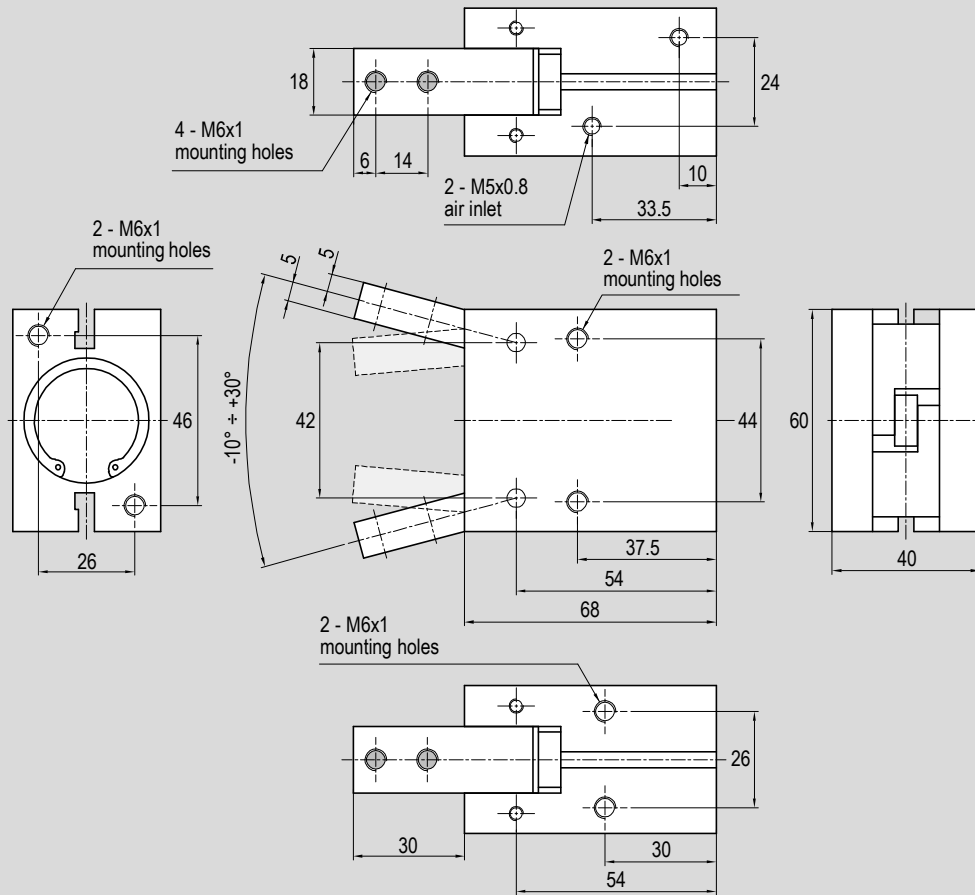

1 - CYLINDERS

Main features

12 ÷ 32

Bores Ø

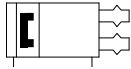

Double acting
Magnetic
Angular 180°

PAC

Type



Technical data

Bore Ø mm		12	16	20	25	32
Fluid	Compressed filtered air.					
Lubrication	Piston	With or without lubrication				
	Lever	Lubrication required on sliding parts.				
Pressure range	1,5 ÷ 7 bar					
Temperature range	0°C ÷ +60°C					
Lever open/close angle	-1° ÷ +180°					
Maximum operation frequency	60/min.					
Ports	M5					
Maximum length of gripping point L		40 mm	80 mm	100 mm	120 mm	140 mm
Theoretical gripping force M (Kgf·cm)	Closing	0,20 x P	0,80 x P	1,70 x P	3,40 x P	6,10 x P
	Opening	0,50 x P	1,10 x P	2,30 x P	4,30 x P	8,10 x P
Effective gripping force F (N)	F = M / L x 0,90					
Weight (g)		100	160	550	750	1230

Key

F = effective gripping force; **M** = theoretical gripping force; **L** = maximum length of gripping point; **P** = operating pressure;
See also table at page 1.60.31

Codes

	PAC Bore Ø mm				
Function	12	16	20	25	32
Double acting	170664	075013	075017	075024	075062

Standard dimensions

Type: PAC

1 - CYLINDERS

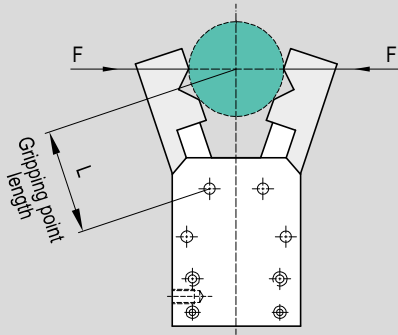

Bore: Ø 12

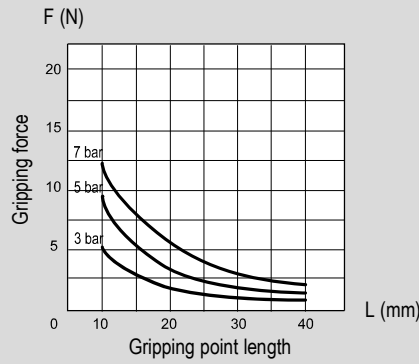

Bore: Ø 16

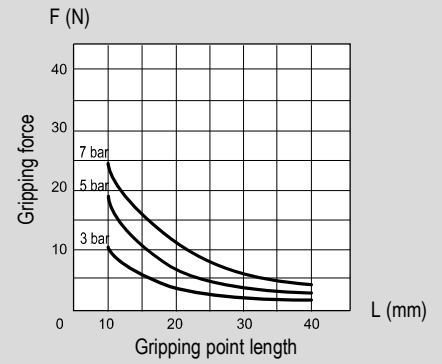

Bore: Ø 20

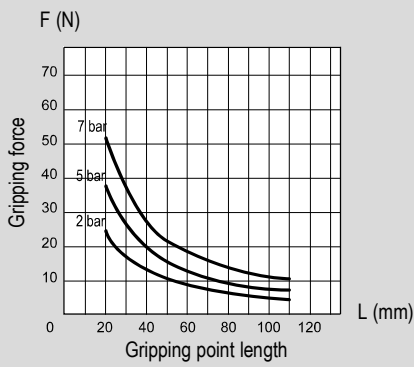

Bore: Ø 25

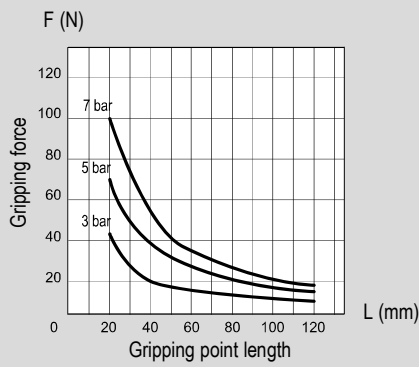

Bore: Ø 32

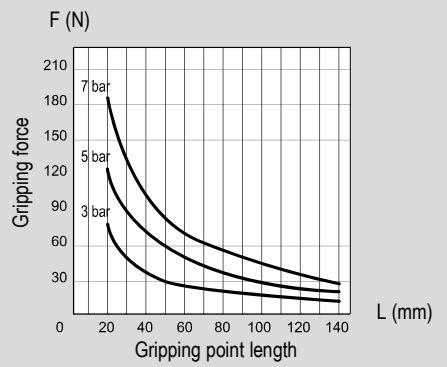

Standard dimensions

Type: PAC
Ø 12

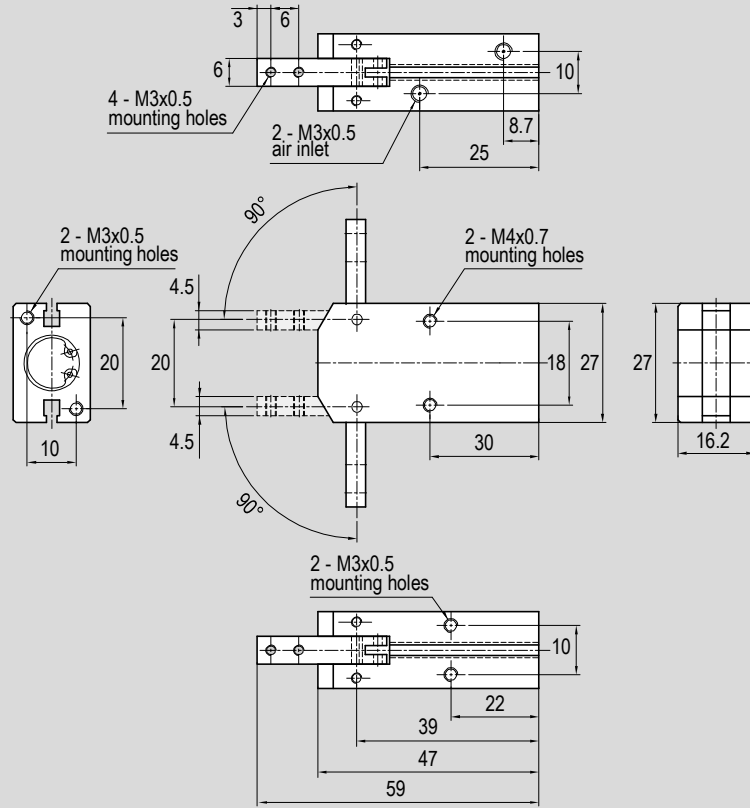

1 - CYLINDERS

Type: PAC
Ø 16

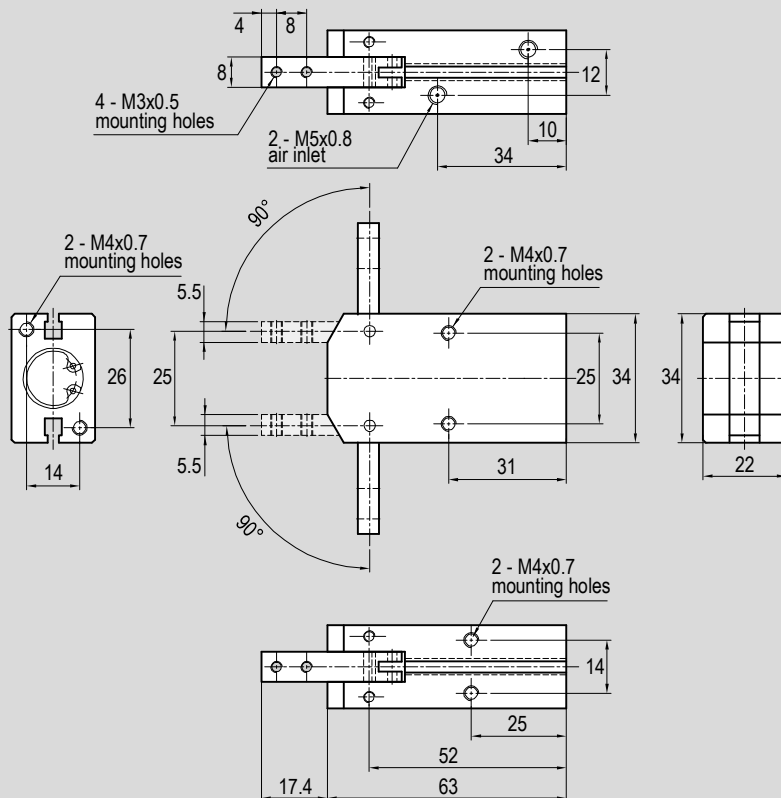

Standard dimensions

1 - CYLINDERS

Type: PAC
Ø 20

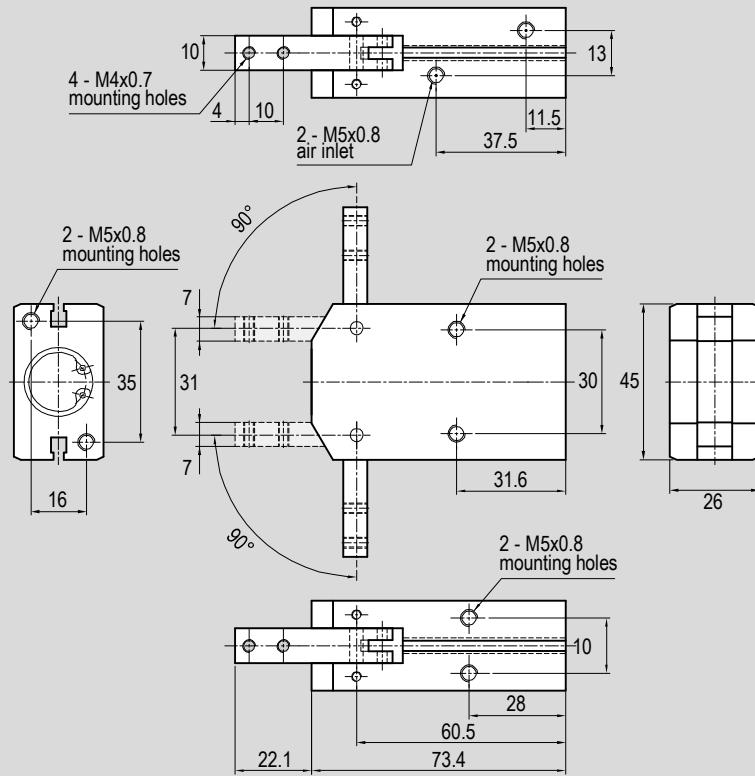

Type: PAC
Ø 25

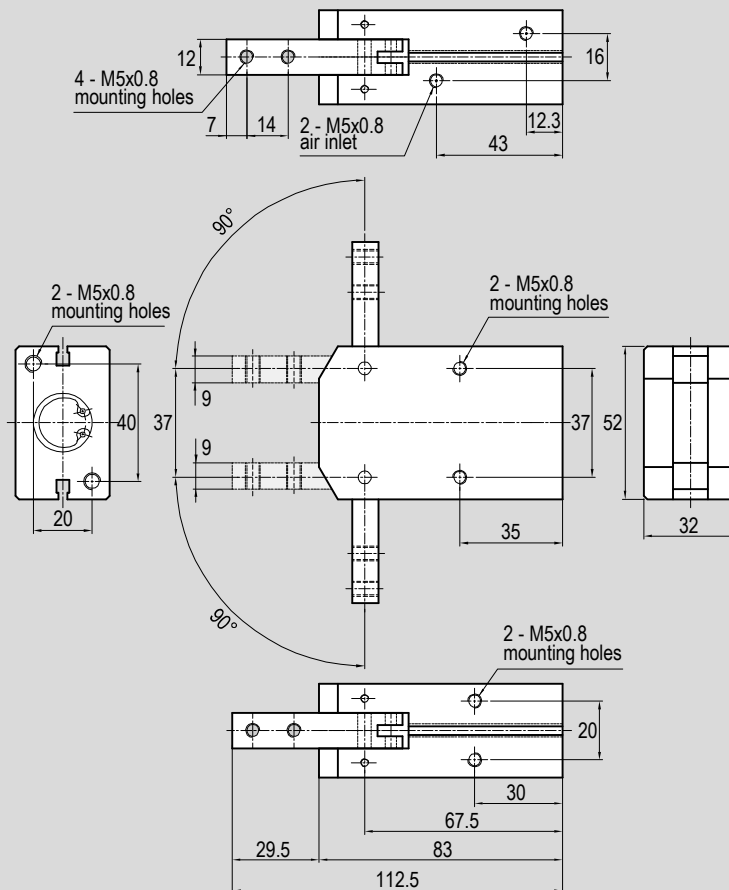

Standard dimensions

Type: PAC
Ø 32

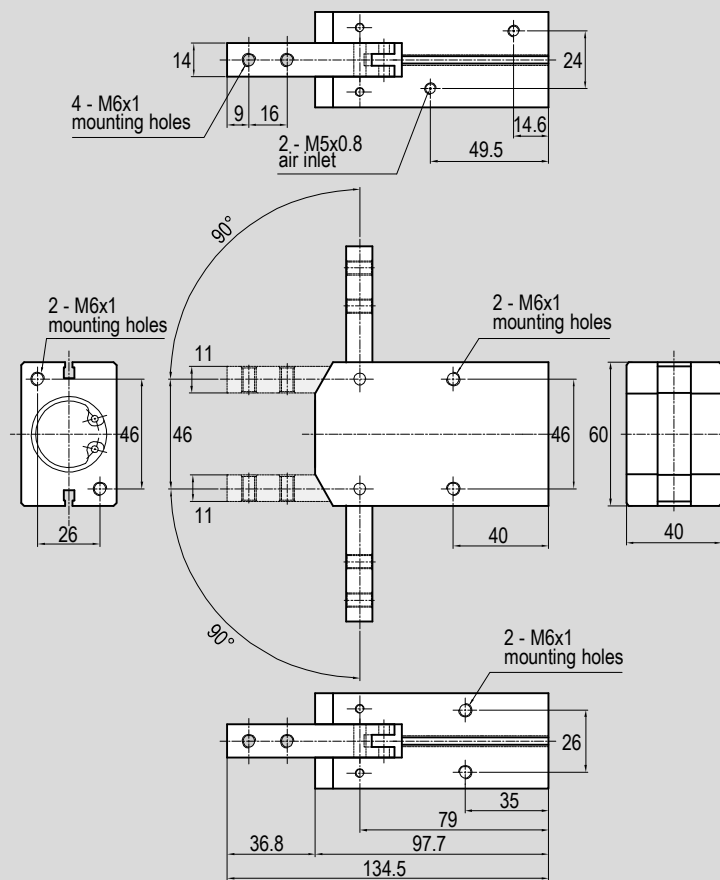

1 - CYLINDERS

Main features

10 ÷ 32

Bores Ø

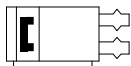

Double acting
Magnetic
Parallel

PPB

Type



Technical data

Bore Ø mm	10	16	20	25	32	
Fluid	Compressed filtered air.					
Lubrication	Piston	With or without lubrication				
	Lever	Lubrication required on sliding parts.				
Pressure range	1,5 ÷ 7 bar					
Temperature range	0°C ÷ +60°C					
Lever open/close stroke	4 mm	8 mm	12 mm	14 mm	16 mm	
Maximum operation frequency	100/min.					
Ports	M3	M5				
Maximum length of gripping point	30 mm	40 mm	60 mm	70 mm	85 mm	
Effective gripping force* (N)	Closing	0,80	2,40	4,70	7,50	10,00
	Opening	0,50	1,80	3,50	6,00	8,50
Weight (g)	120	160	550	750	1230	

*See also table at page 1.60.41

Codes

Function	PPB Bore Ø mm				
	10	16	20	25	32
Double acting	075025	075027	075063	075028	075029

Gripping forces

Type: PPB

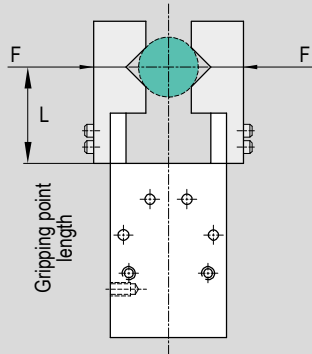

Bore: Ø 10

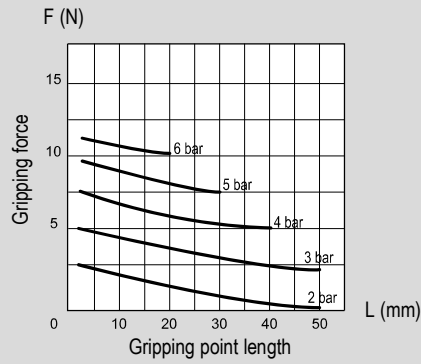

Bore: Ø 16

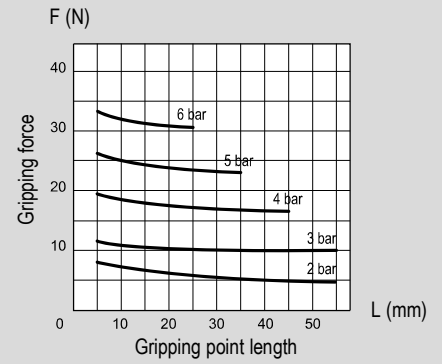

Bore: Ø 20

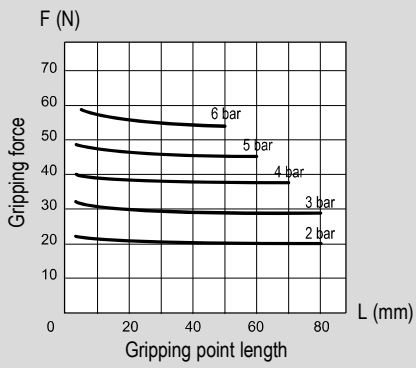

Bore: Ø 25

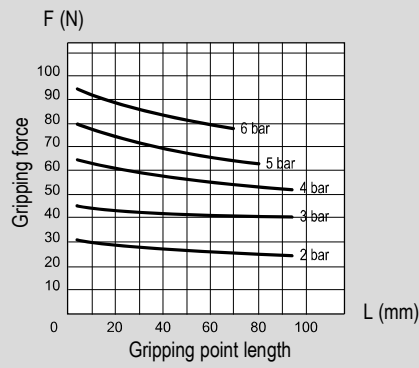

Bore: Ø 32

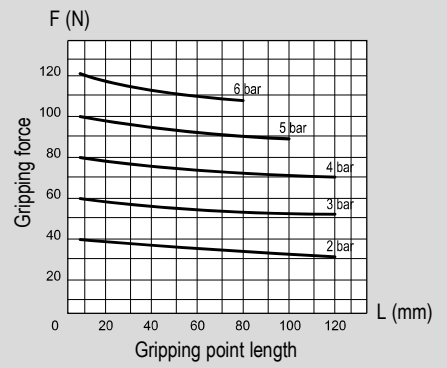

Standard dimensions

1 - CYLINDERS

Type: **PPB**
Ø 10

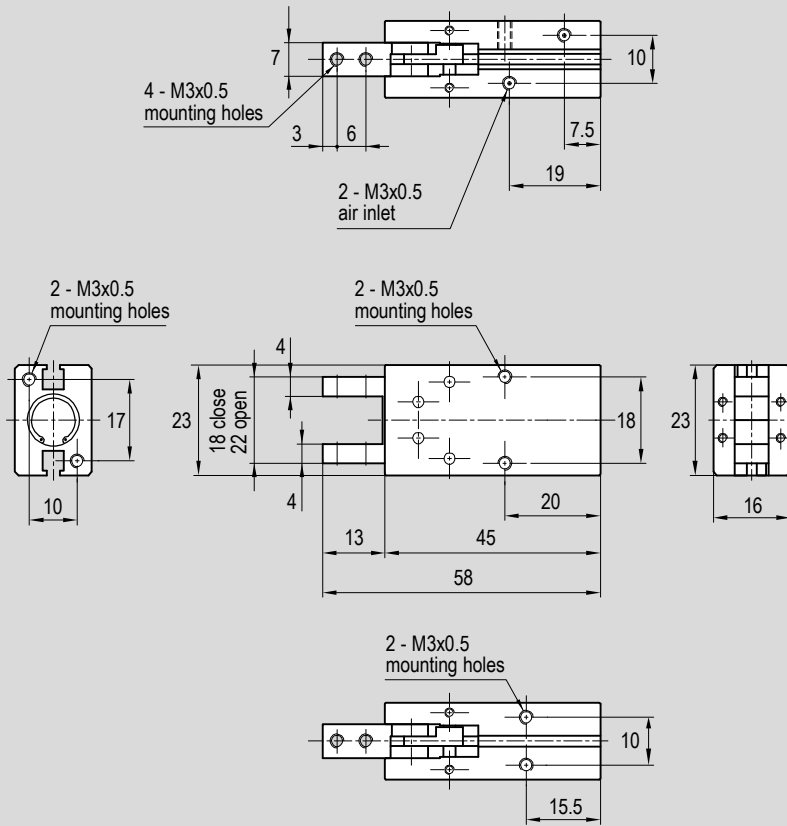

Type: **PPB**
Ø 16

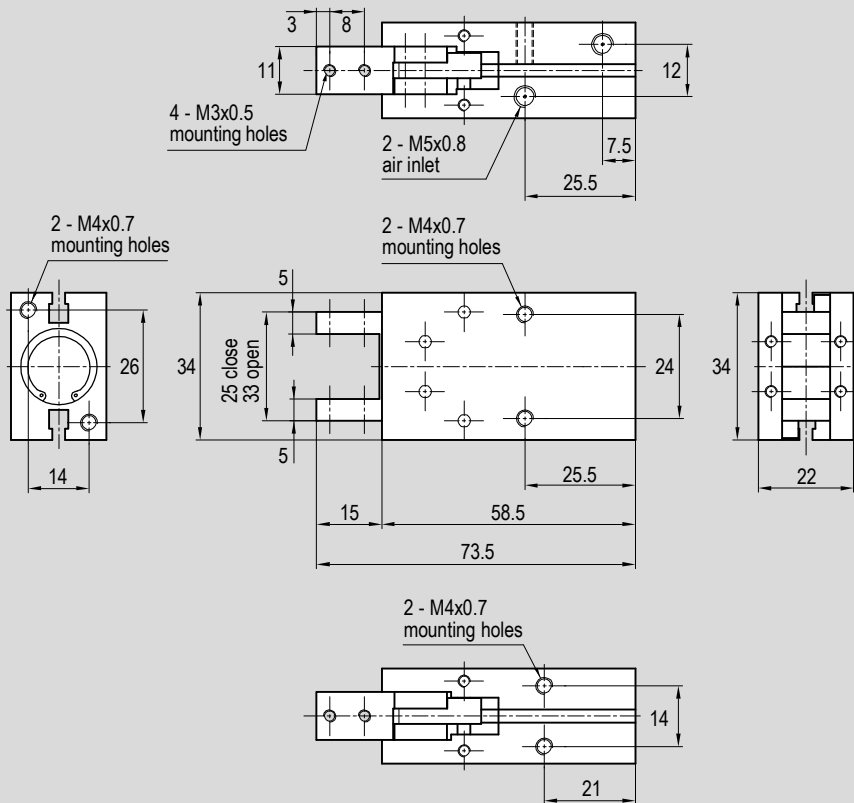

Standard dimensions

Type: **PPB**
Ø 20

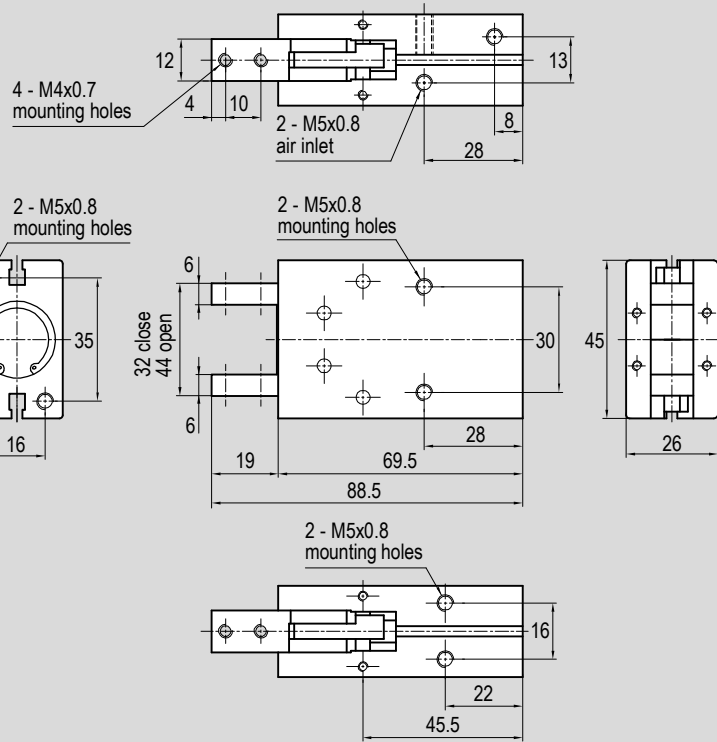

1 - CYLINDERS

Type: **PPB**
Ø 25

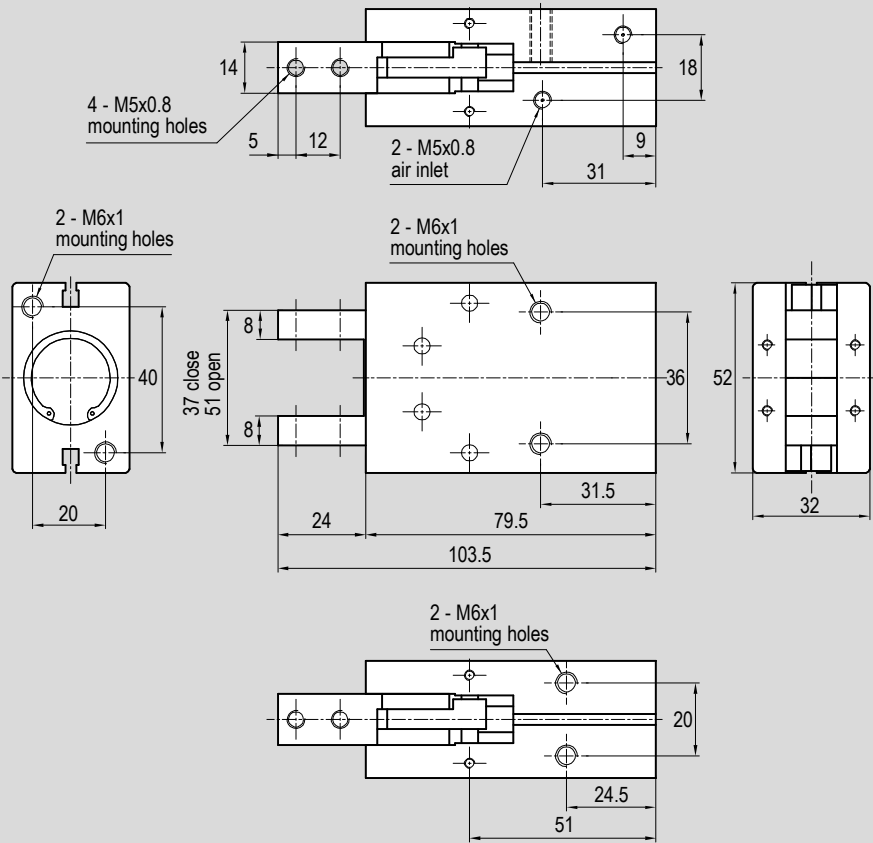

Standard dimensions

Type: **PPB**
Ø 32

1 - CYLINDERS

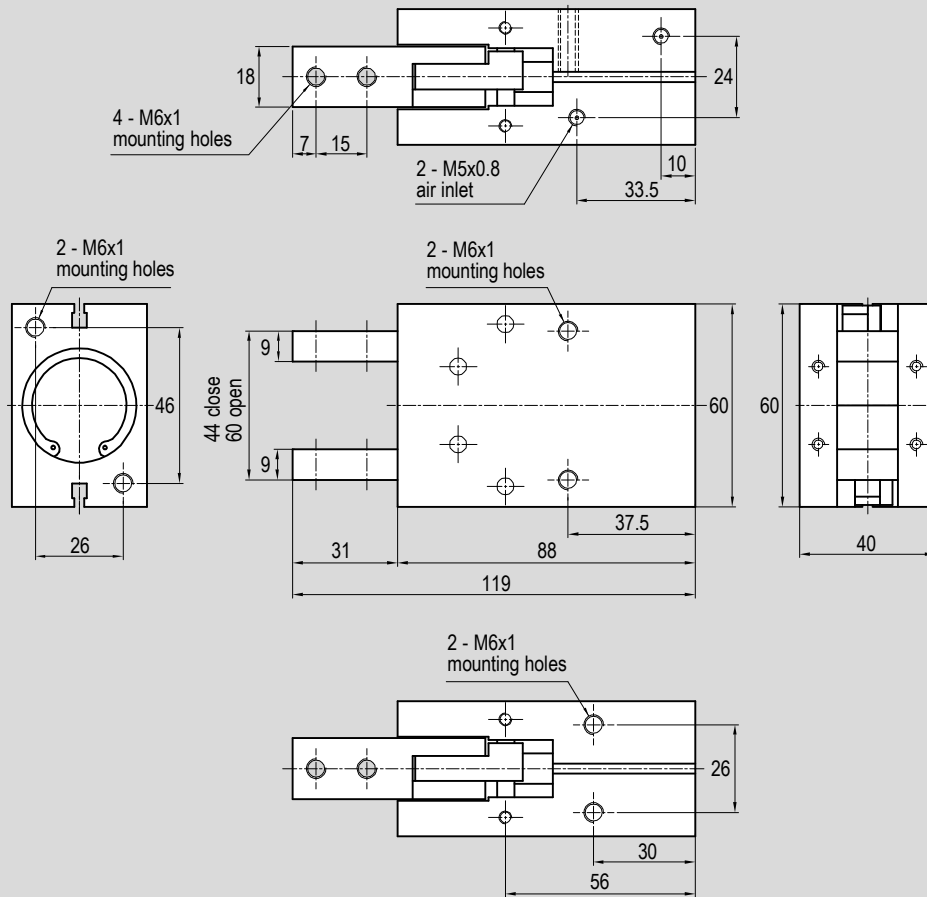

Main features

6 ÷ 40

Bores Ø

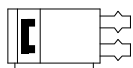

Double acting
Magnetic
Guided Parallel

PPC

Type



Technical data

Bore Ø mm	6	10	16	20	25	32	40		
Fluid	Compressed filtered air.								
Lubrication	Non richiesta								
Pressure range	2 ÷ 7 bar		1 ÷ 7 bar						
Temperature range	0°C ÷ +60°C								
Lever open/close stroke	4 mm		6 mm	10 mm	14 mm	22 mm	30 mm		
Maximum operation frequency	100/min.					60/min.			
Ports	M3		M5						
Effective gripping force* (N)	Double acting	Opening	6,1	17,0	45,0	66,0	104,0	193,0	318,0
		Closing	3,3	11,0	34,0	42,0	65,0	158,0	254,0
	Single acting	Closing	1,9	7,1	27,0	33,0	45,0	131,0	217,0
Weight (g)	25	60	140	270	490	810	1.370		

*See also tables at page 1.60.51 and 1.60.52

Codes

Function	PPC Bore Ø mm						
	6	10	16	20	25	32	40
Double acting	170667	170668	075030	075031	075034	075035	170669
Single acting	170678	170679	170680	170681	170682	170683	170684

Gripping forces

Type: PPC

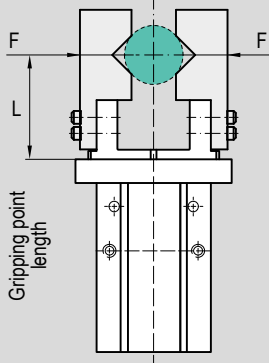

Bore: Ø 6

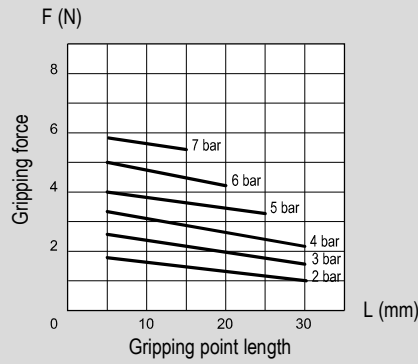

Bore: Ø 10

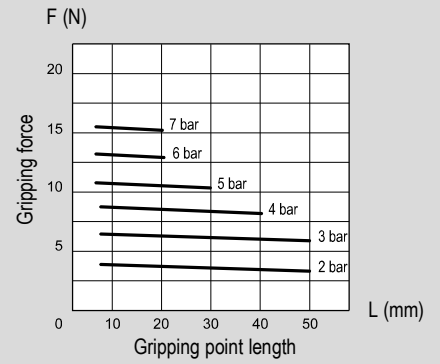

Bore: Ø 16

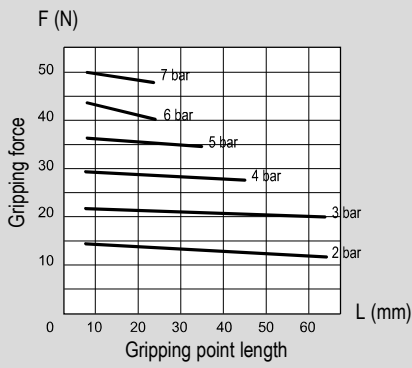

Bore: Ø 20

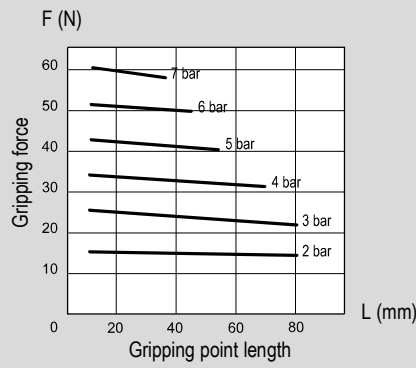

Bore: Ø 25

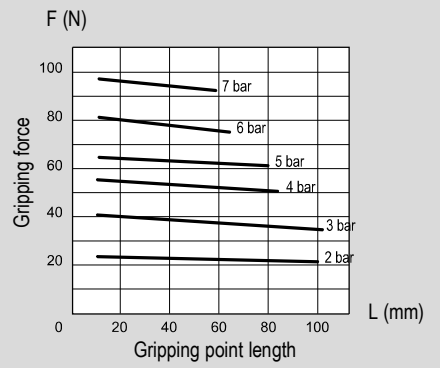

Bore: Ø 32

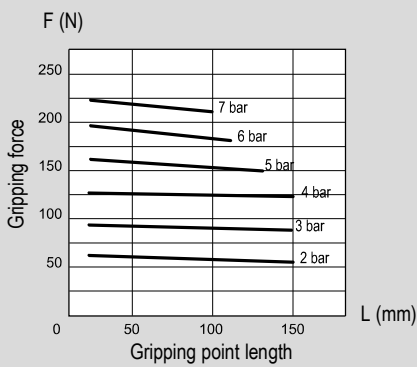

Bore: Ø 40

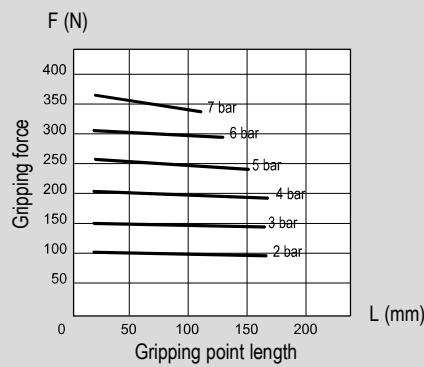

Gripping forces

Type: PPC

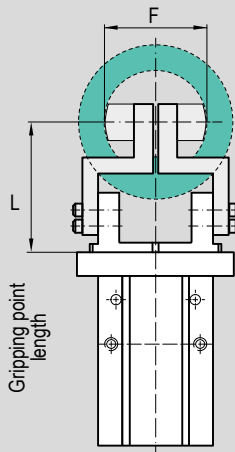

Bore: Ø 6

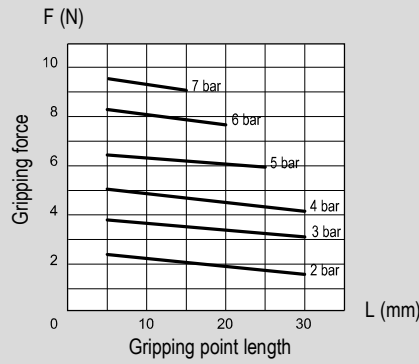

Bore: Ø 10

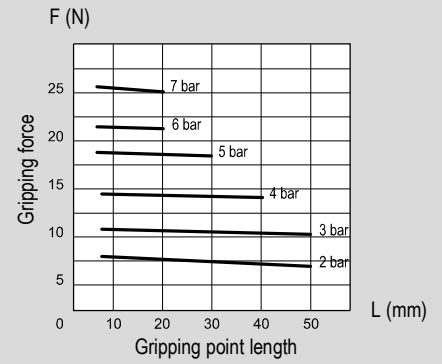

Bore: Ø 16

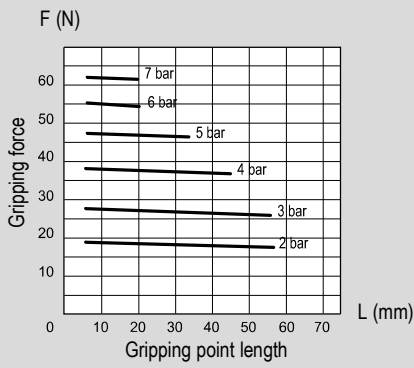

Bore: Ø 20

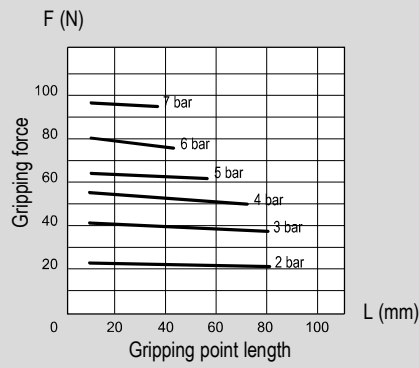

Bore: Ø 25

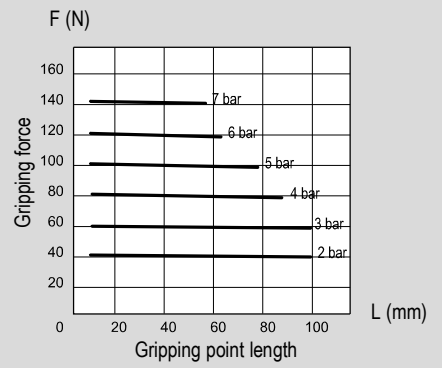

Bore: Ø 32

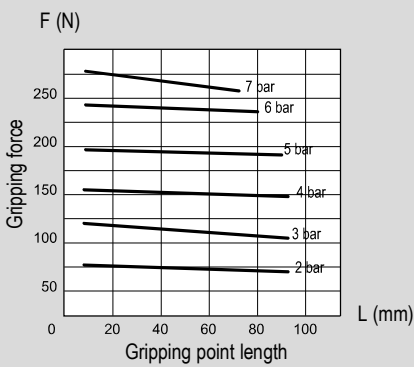

Bore: Ø 40

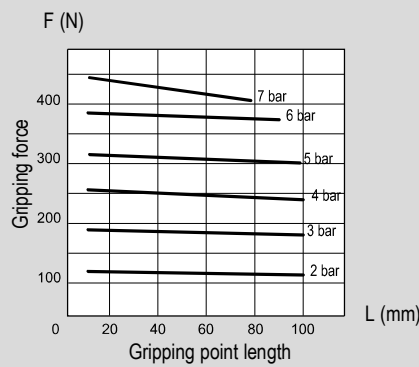

Standard dimensions

1 - CYLINDERS

Type: PPC
Ø 6

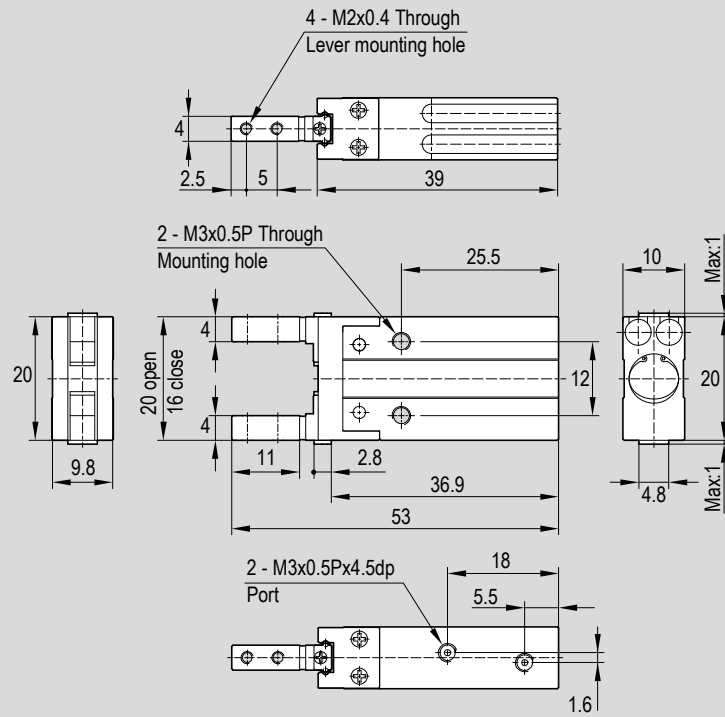

Type: PPC
Ø 10

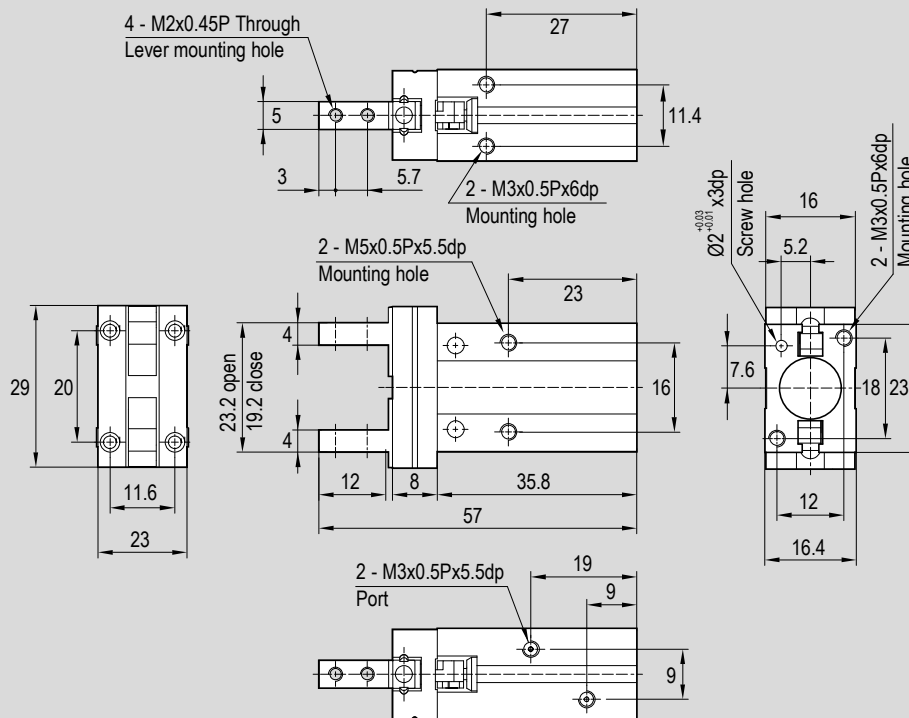

Standard dimensions

Type: PPC
Ø 16

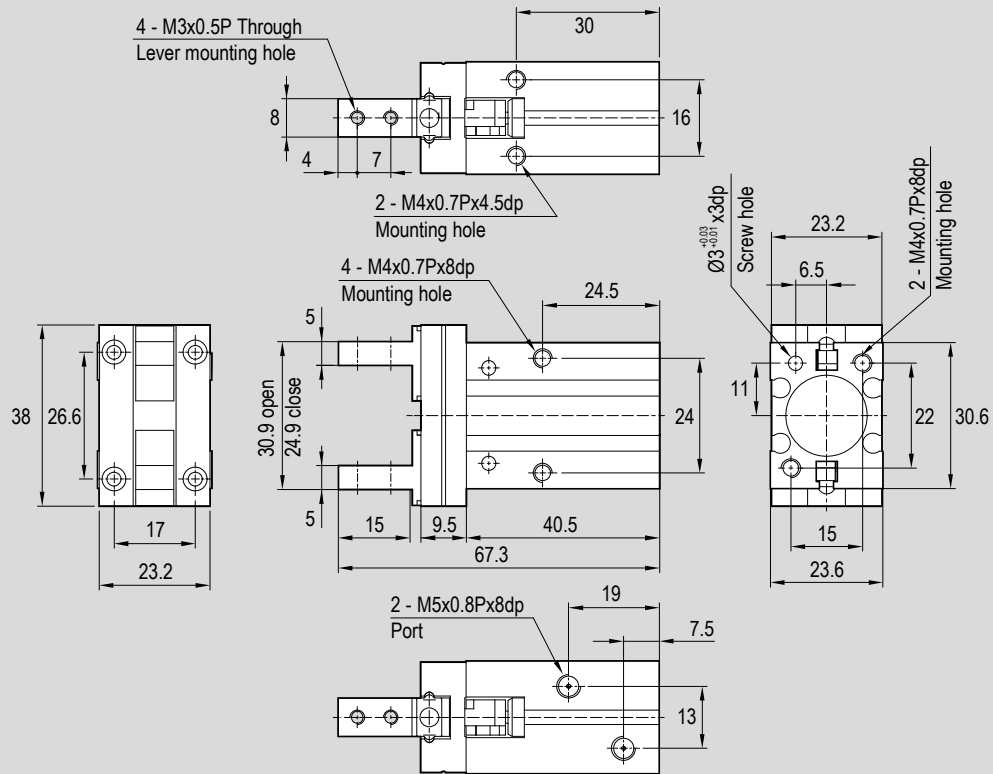

1 - CYLINDERS

Type: PPC
Ø 20

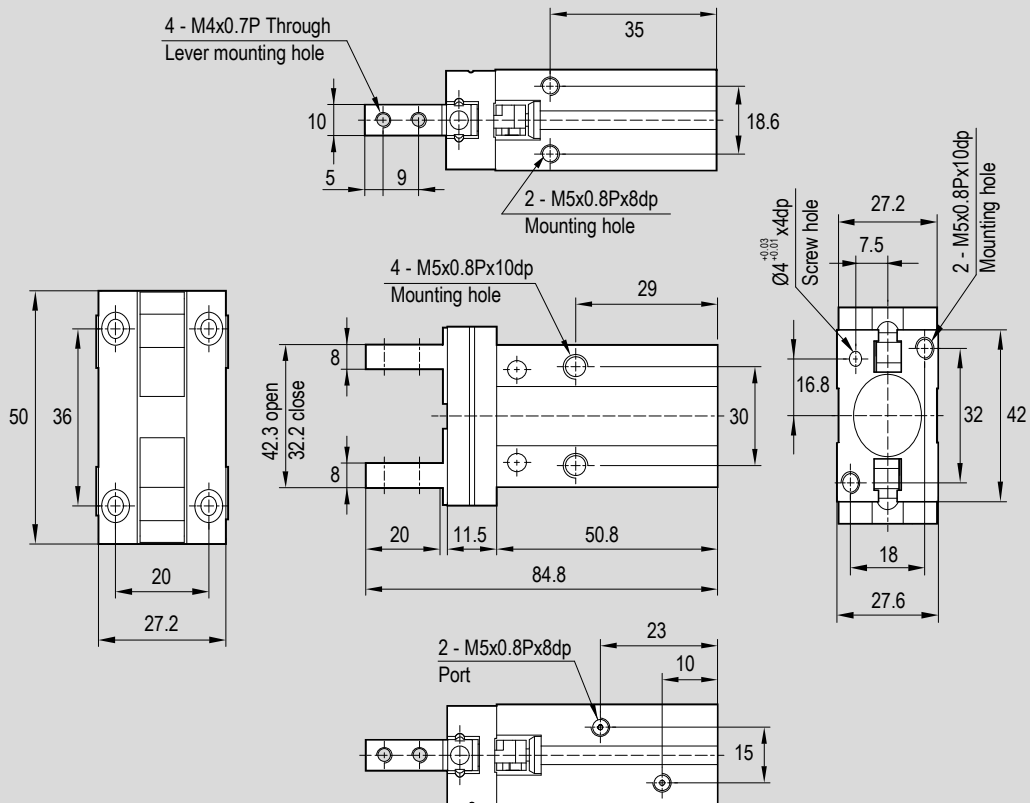

Standard dimensions

1 - CYLINDERS

Type: PPC
Ø 25

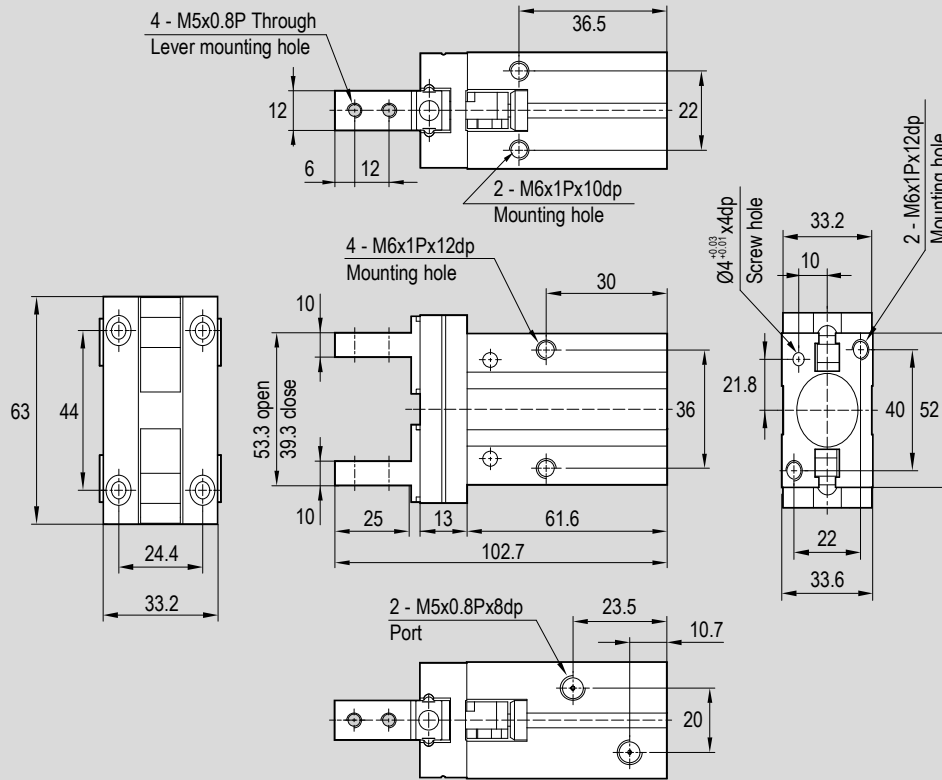

Type: PPC
Ø 32

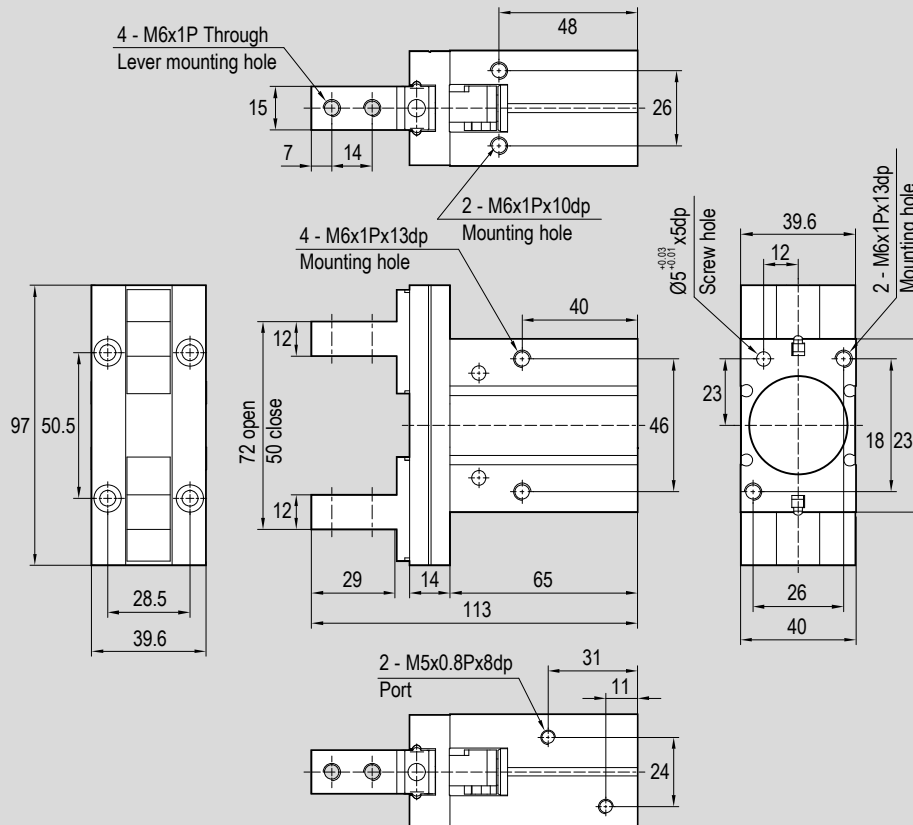

Standard dimensions

Type: PPC
Ø 40

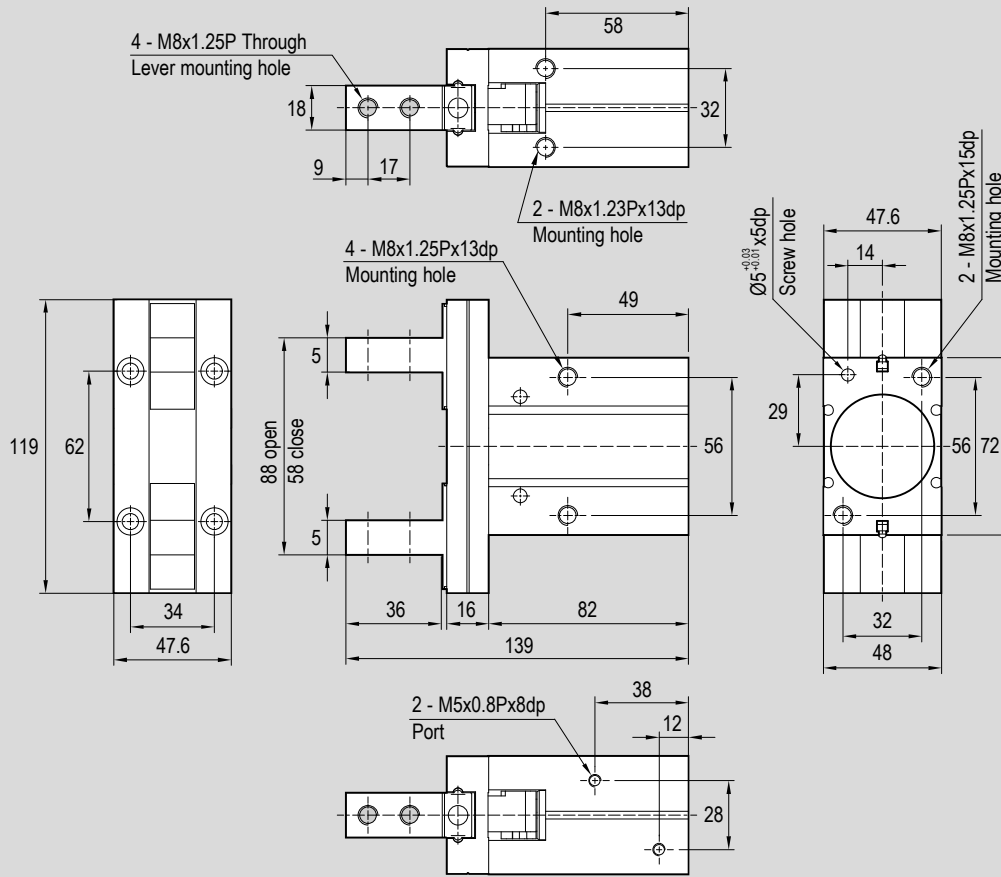

Main features

10 ÷ 40

Bores Ø

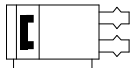

Double acting
Magnetic
Parallel Long Stroke

PPD

Type



Technical data

Bore Ø mm	10	16	20	25	32	40												
Fluid	Compressed filtered air.																	
Lubrication	Not required																	
Pressure range	1,5 ÷ 7 bar																	
Temperature range	0°C ÷ +60°C																	
Lever open/close stroke (mm)	20	40	60	30	60	80	40	80	100	50	100	120	70	120	160	100	160	200
Maximum operation frequency	40/min.												20/min.					
Ports	M5																1/8"	
Maximum length of gripping point	40 mm			60 mm			80 mm			90 mm			100 mm					
Effective gripping force* (N)	14			44			73			128			228			396		
Weight (g)	290	350	440	570	790	940	1.000	1.450	1.700	1.700	2.600	2.800	3.000	4.003	5.000	5.300	6.900	8.000

*Gripping point 30 mm at 5 bar; see also tables at page 1.60.61 and 1.60.62

Codes and standard strokes

	PPD Bore Ø mm					
Stroke mm	10	16	20	25	32	40
20	075037					
30		075040				
40	075038		075044			
50				075048		
60	075039	075041				
70					075051	
80		075042	075045			
100			075047	075049		170670
120				075050	075052	
160					075002	170671
200						170672

Key
 Standard stroke

Gripping forces

Type: PPD

1 - CYLINDERS

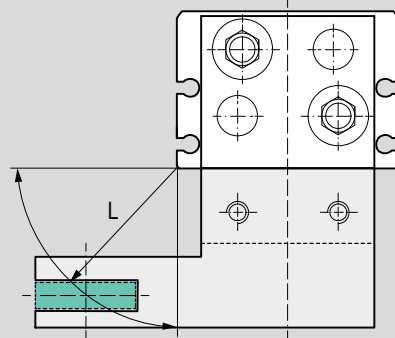
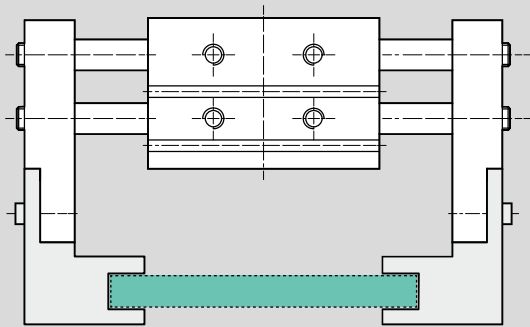

Bore: $\varnothing 10$
Stroke: 20 mm

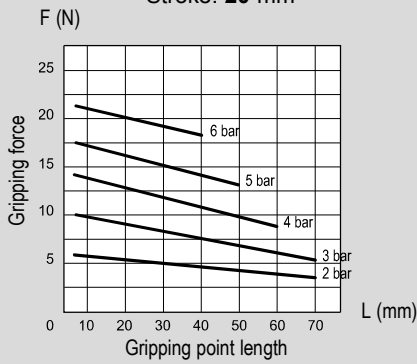

Bore: $\varnothing 10$
Stroke: 40 mm

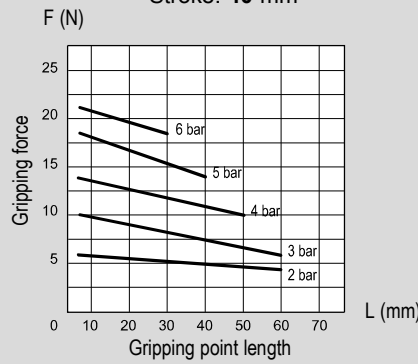

Bore: $\varnothing 10$
Stroke: 60 mm

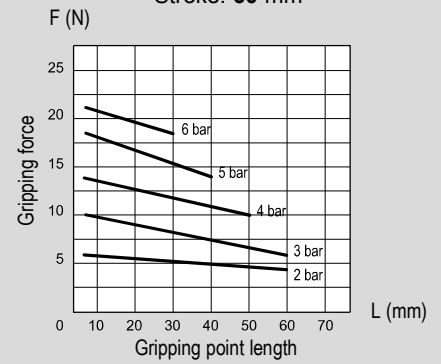

Bore: $\varnothing 16$
Stroke: 30 mm

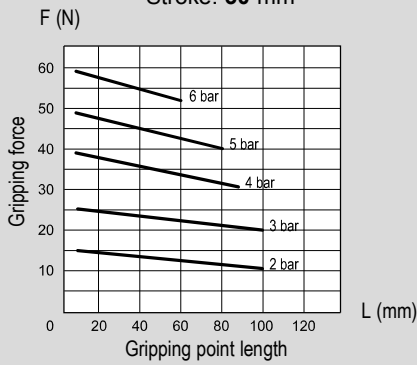

Bore: $\varnothing 16$
Stroke: 60 mm

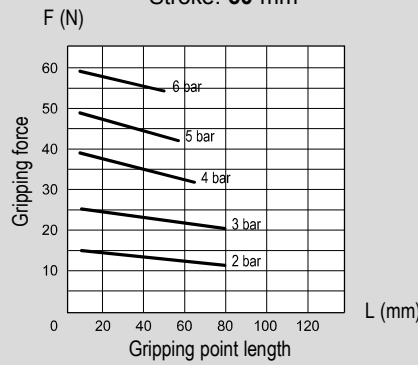

Bore: $\varnothing 16$
Stroke: 80 mm

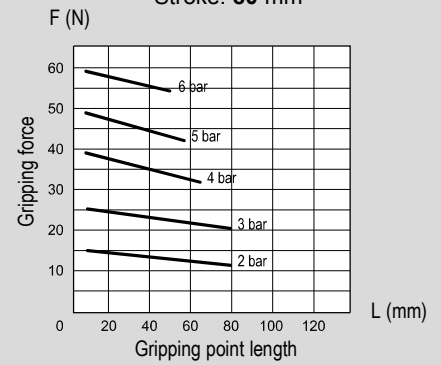

Bore: $\varnothing 20$
Stroke: 40 mm

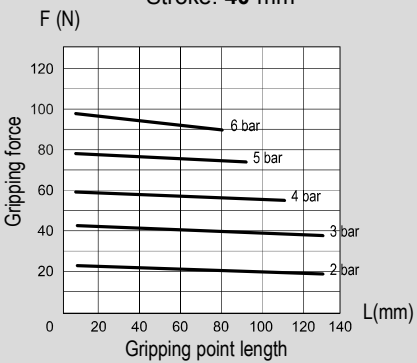

Bore: $\varnothing 20$
Stroke: 80 mm

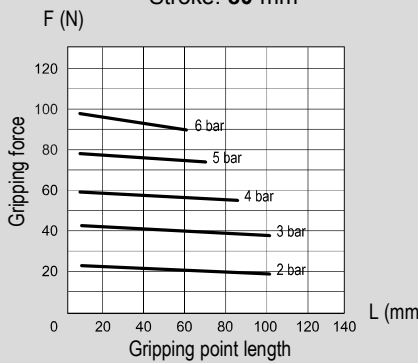

Bore: $\varnothing 20$
Stroke: 100 mm

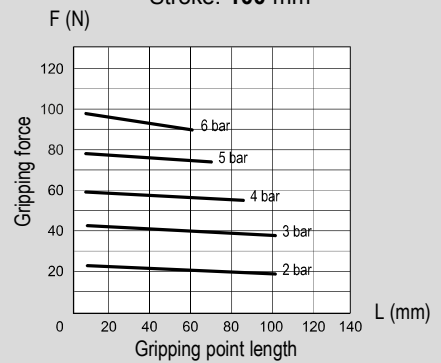

Gripping forces

Type: PPD

1 - CYLINDERS

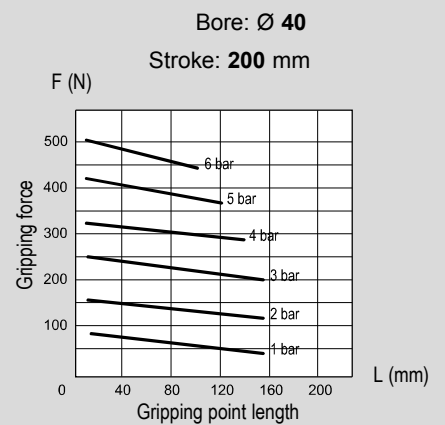
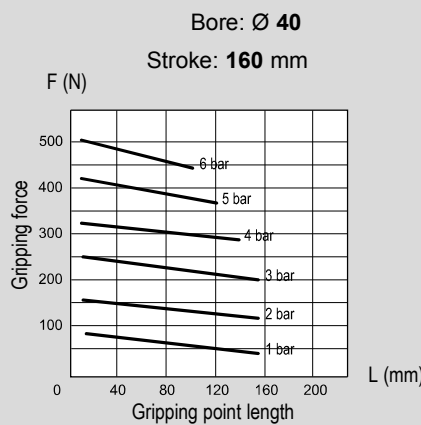
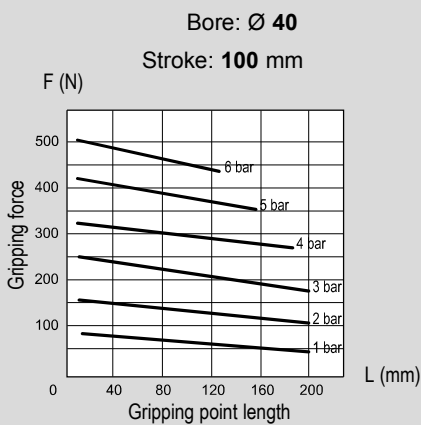
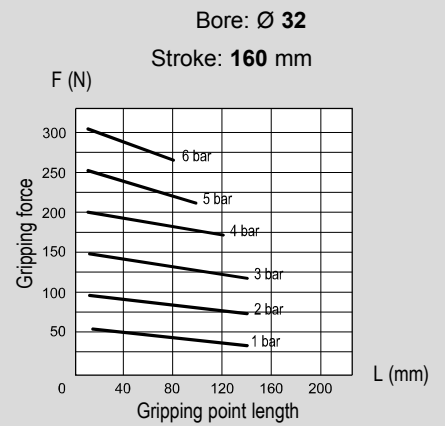
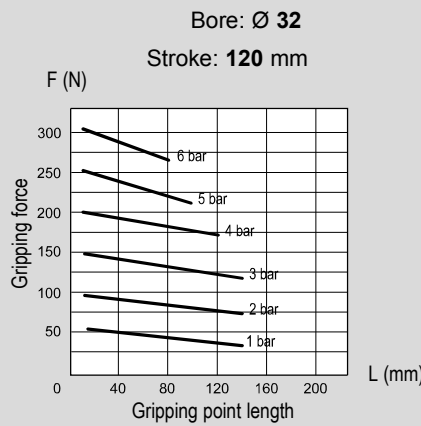
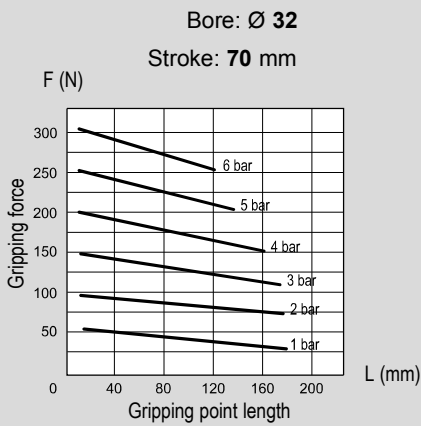
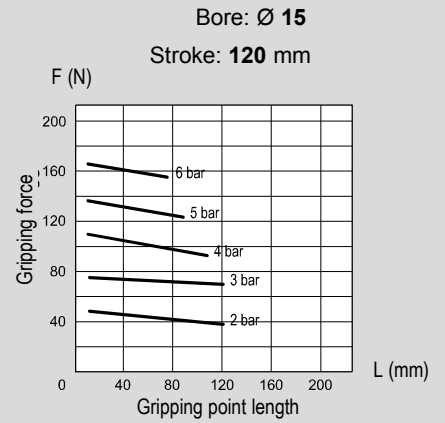
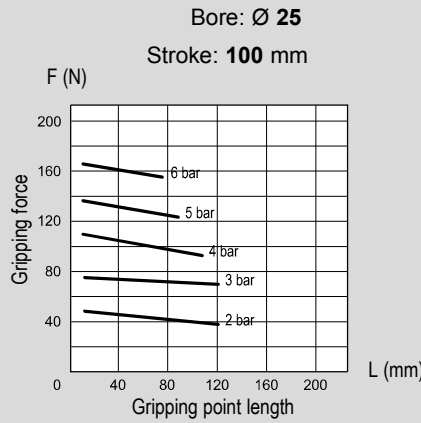
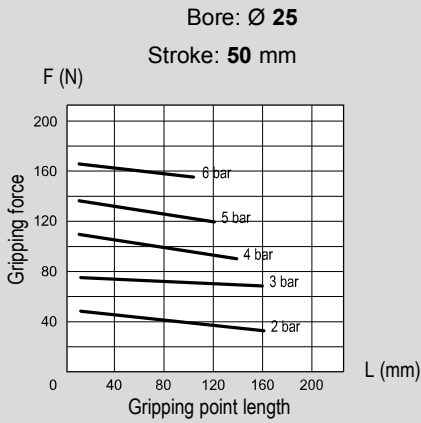

Standard dimensions

Type: PPD
Ø 10

1 - CYLINDERS

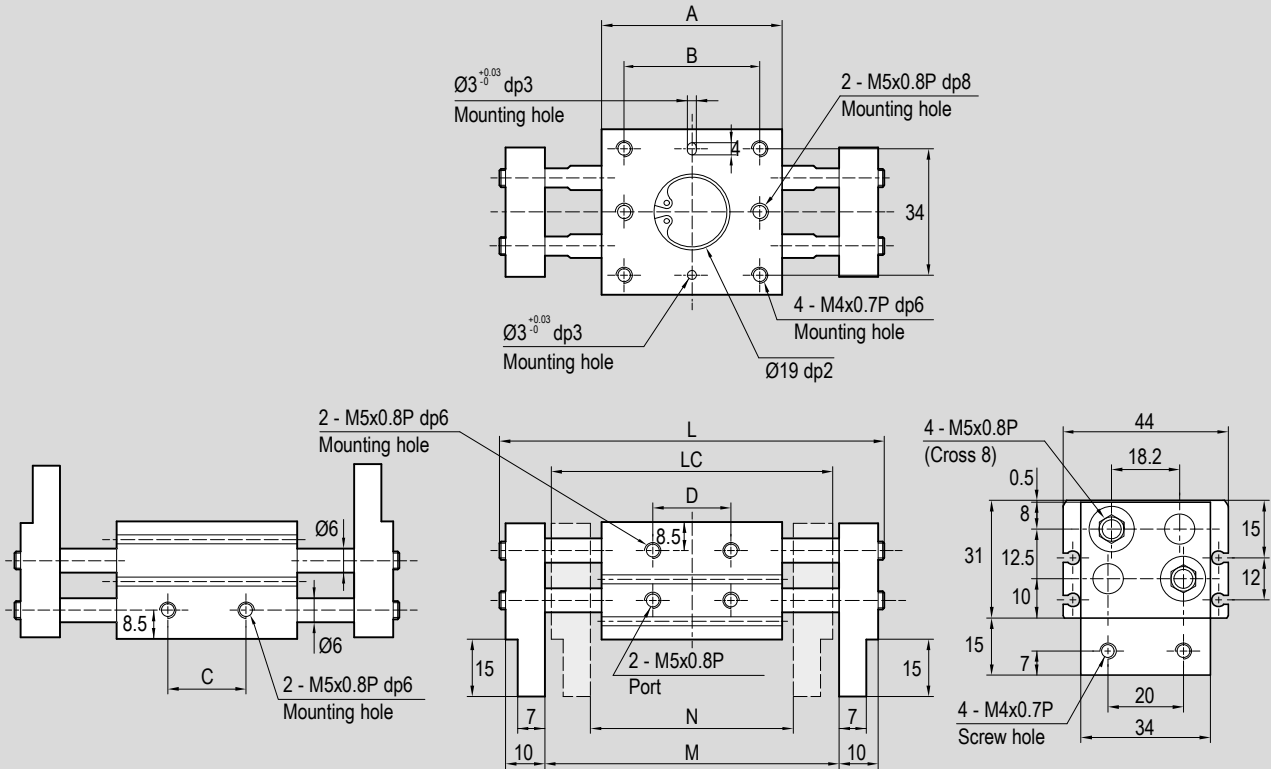

Lever stroke (mm)	A	B	C	D	L	LC	M	N
20	52	36	30	30	100	80	76	56
40	68	52	46	46	136	96	112	72
60	86	70	64	64	174	114	150	90

Standard dimensions

Type: PPD
Ø 16

1 - CYLINDERS

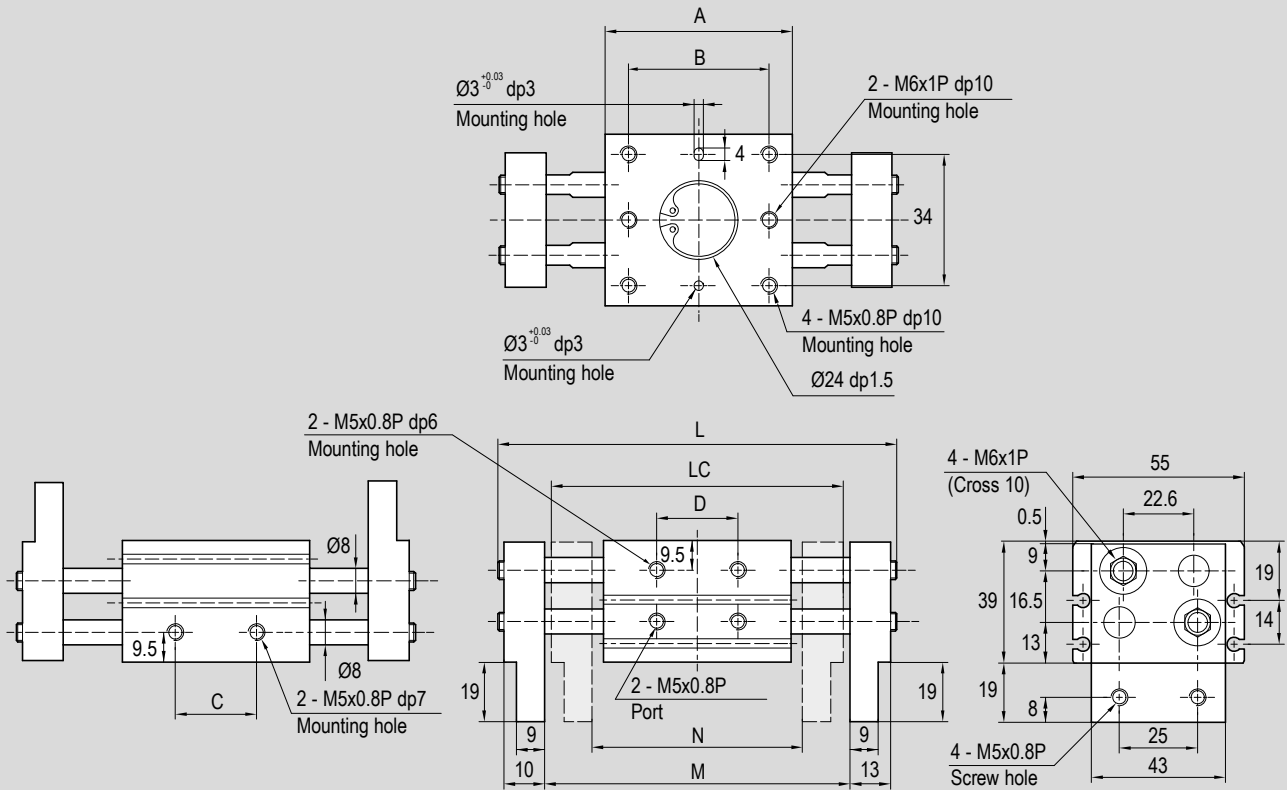

Lever stroke (mm)	A	B	C	D	L	LC	M	N
30	60	45	26	26	128	98	98	68
60	90	75	56	56	188	128	158	98
80	110	95	76	76	228	148	198	118

Dimensioni standard

Tipo: PPD
Ø 20

1 - CILINDRI

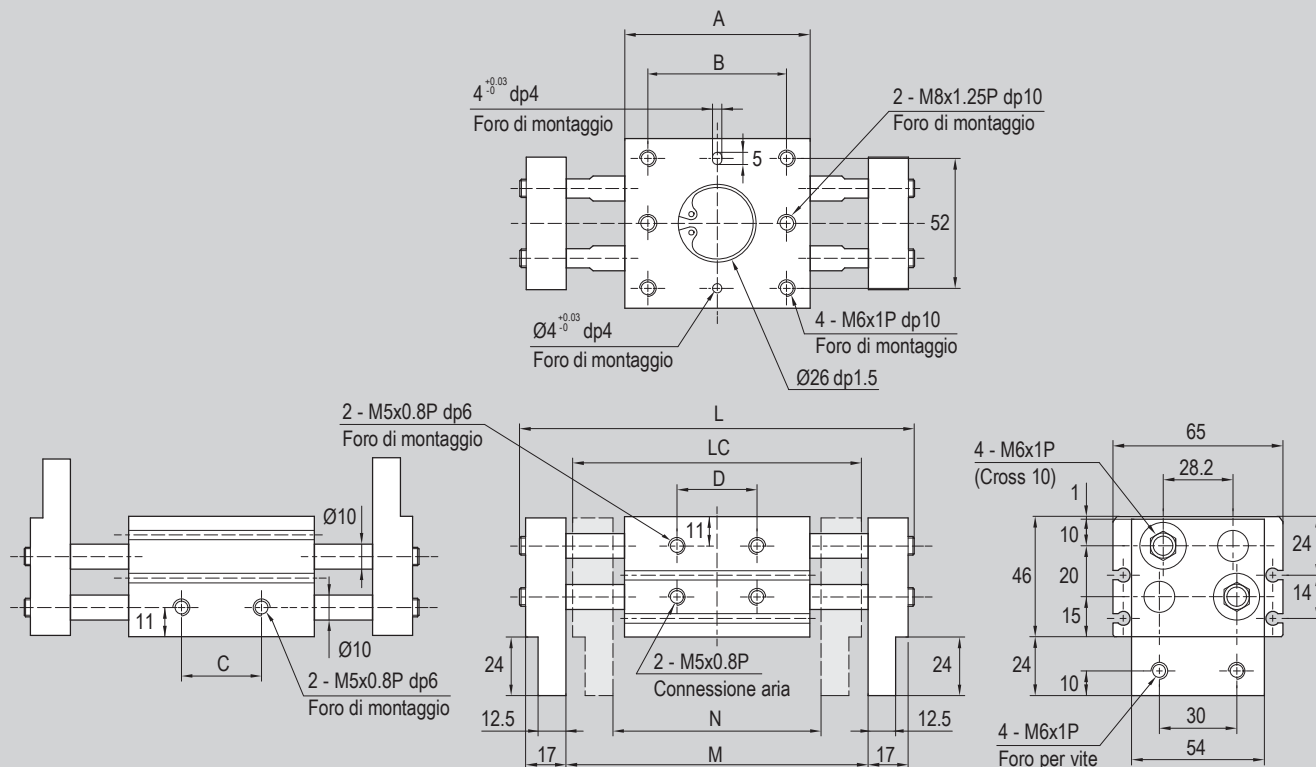

corsa leve (mm)	A	B	C	D	L	LC	M	N
40	71	58	40	40	157	113	119	79
80	113	100	82	82	239	159	201	121
100	133	120	102	102	279	179	241	141

Dimensioni standard

Tipo: PPD
Ø 25

1 - CILINDRI

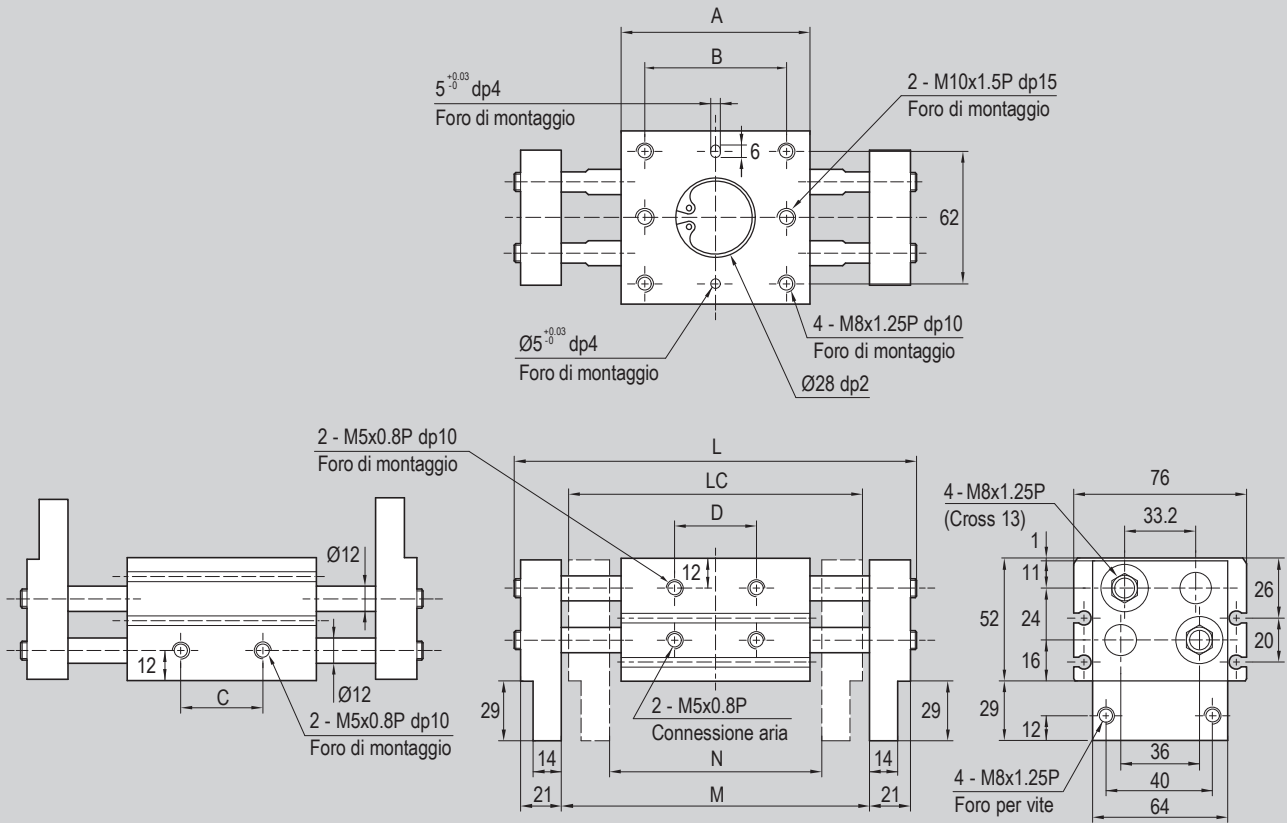

corsa leve (mm)	A	B	C	D	L	LC	M	N
50	88	70	50	50	192	138	146	96
100	142	124	104	104	296	196	250	150
120	160	142	122	122	334	214	288	168

Standard dimensions

Type: PPD
Ø 32

1 - CYLINDERS

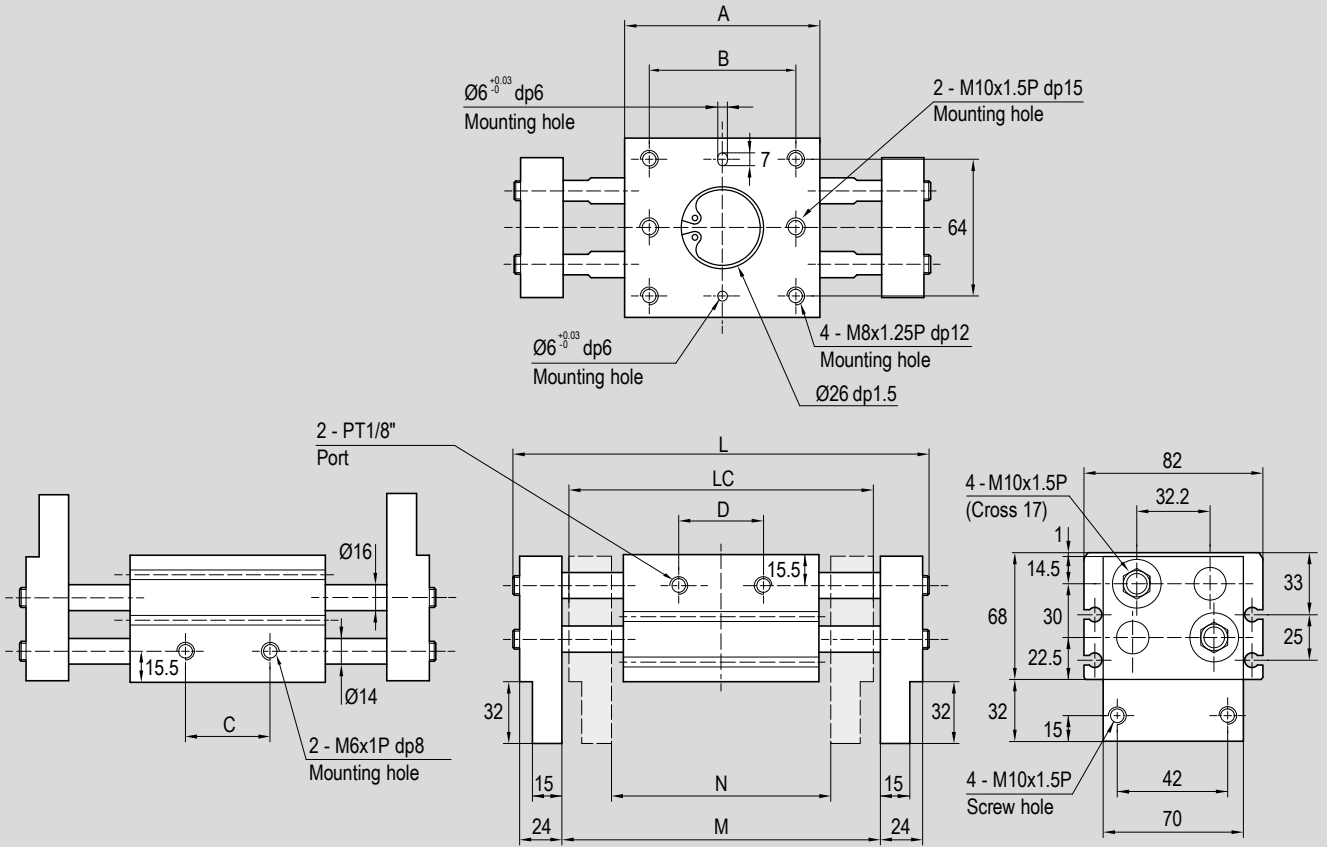

Lever stroke (mm)	A	B	C	D	L	LC	M	N
70	110	86	69	69	240	170	188	118
120	158	134	117	117	338	218	286	166
160	202	178	161	161	422	262	370	210

Standard dimensions

Type: PPD
Ø 40

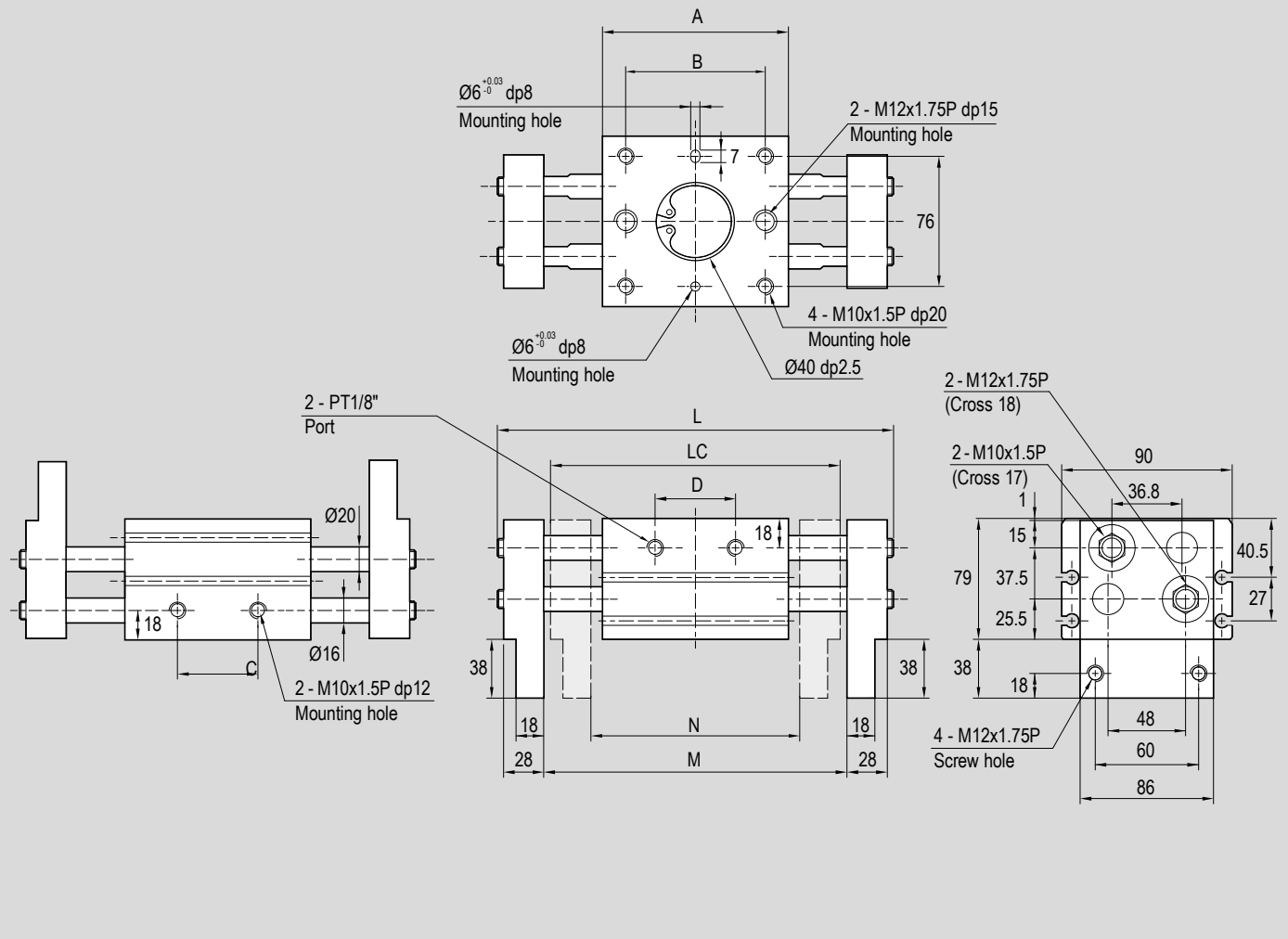

1 - CYLINDERS

Lever stroke (mm)	A	B	C	D	L	LC	M	N
100	148	116	80	80	324	224	264	164
160	206	174	138	138	442	282	382	222
200	246	214	178	178	522	322	462	262

Dimensions options

1 - CYLINDERS

Type: ..B
Ø 10

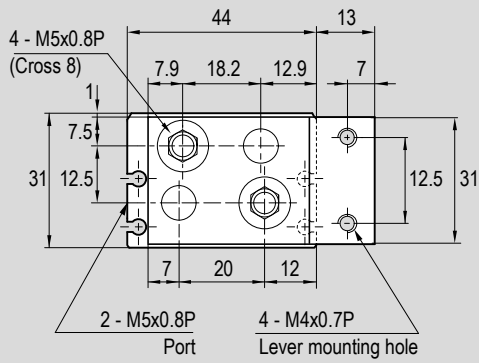

Type: ..B
Ø 16

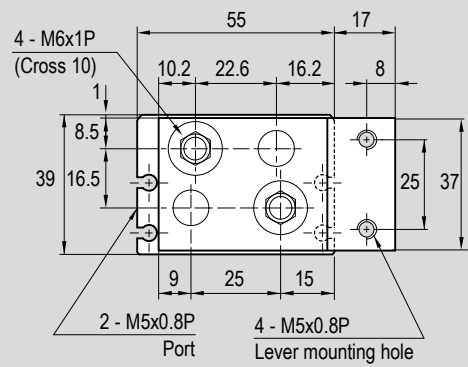

Type: ..B
Ø 20

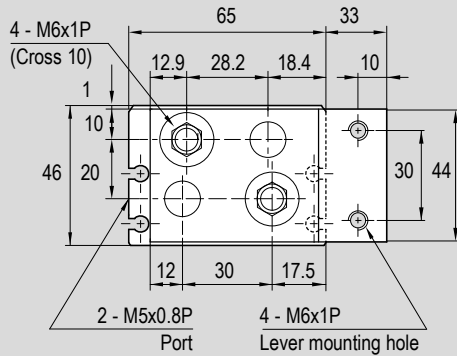

Type: ..B
Ø 25

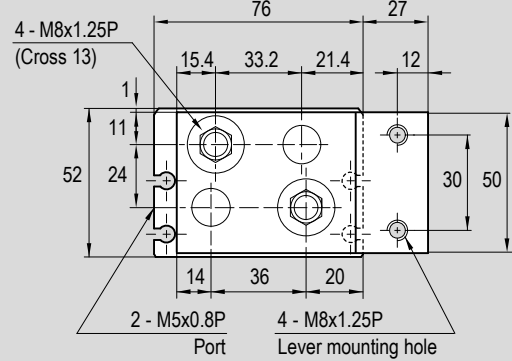

Type: ..B
Ø 32

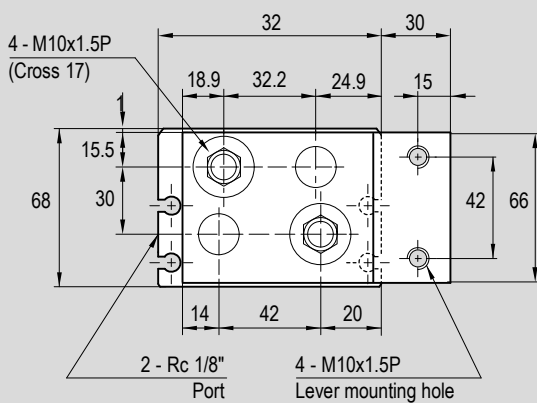

Type: ..B
Ø 40

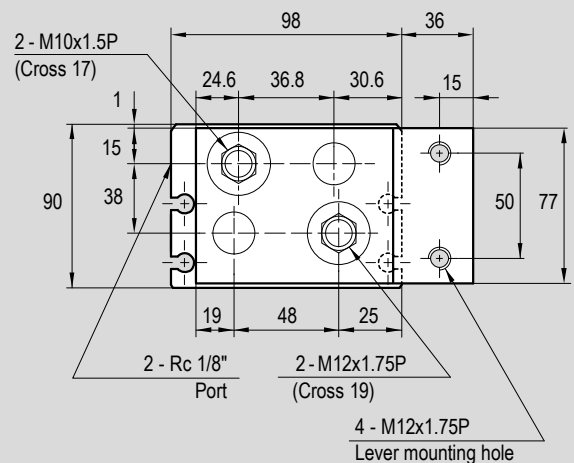

Main features

16 ÷ 100

Bores Ø

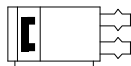

Double acting
Magnetic
3 Fingers

PPE

Type



Technical data

Bore Ø mm	16	20	25	32	40	50	63	80	100	
Fluid	Compressed filtered air.									
Lubrication	Not required									
Pressure range	3 ÷ 7 bar									
Temperature range	0°C ÷ +60°C									
Lever open/close stroke	4 mm	6 mm	8 mm	12 mm	16 mm	20 mm	24 mm			
Maximum operation frequency	120/min.			60/min.				30/min.		
Ports	Side	M3		M5				1/8"	1/4"	
	End cover	-			M5				1/8"	
Effective gripping force (N)	Open	21,0	37,0	63,0	111,0	177,0	280,0	502,0	710,0	1.068,0
	Close	23,0	42,0	71,0	123,0	195,0	306,0	537,0	748,0	1.111,0
Weight (g)	60	98	146	295	378	561	1.032	1.768	3.224	

Codes

Function	PPE Bore Ø mm								
	16	20	25	32	40	50	63	80	100
Double acting	170673	170674	075053	075054	075055	075056	075057	170675	170676

Standard dimensions

Type: **PPE**
Ø 16

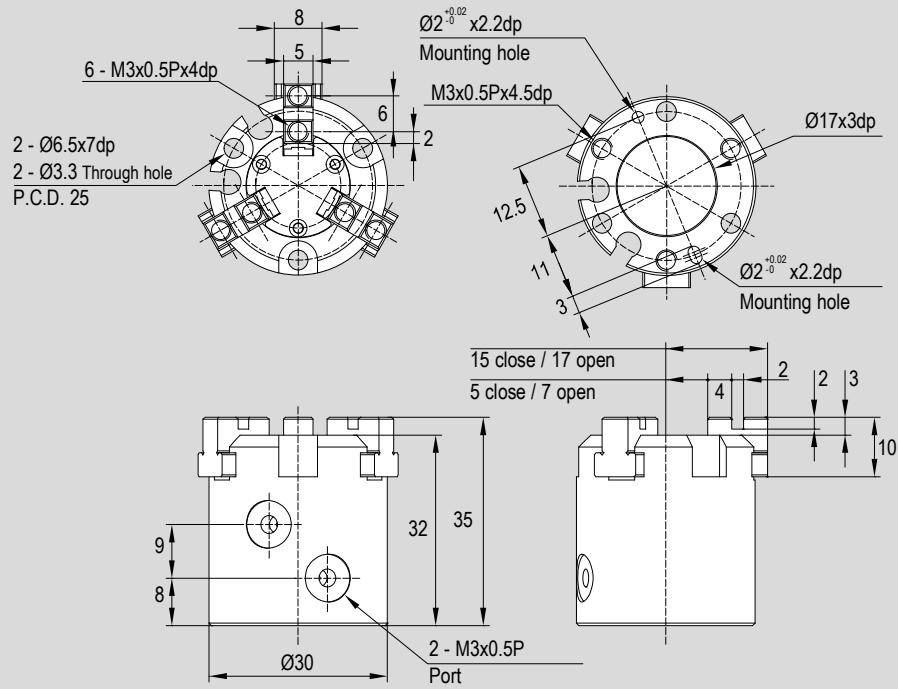

Type: **PPE**
Ø 20

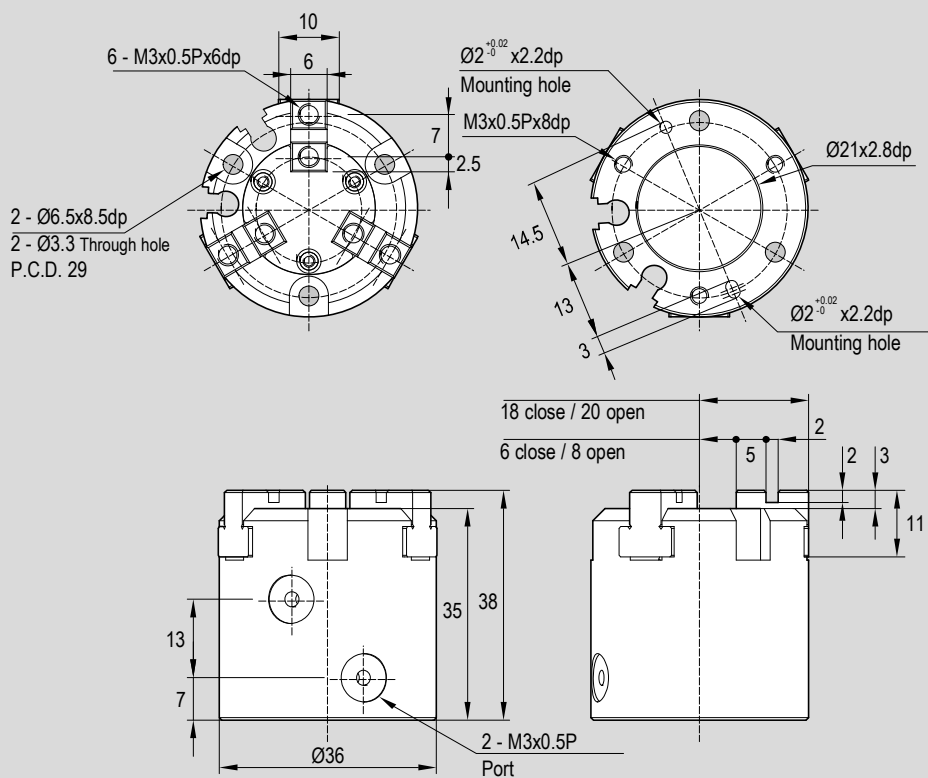

Standard dimensions

Type: **PPE**
Ø 25

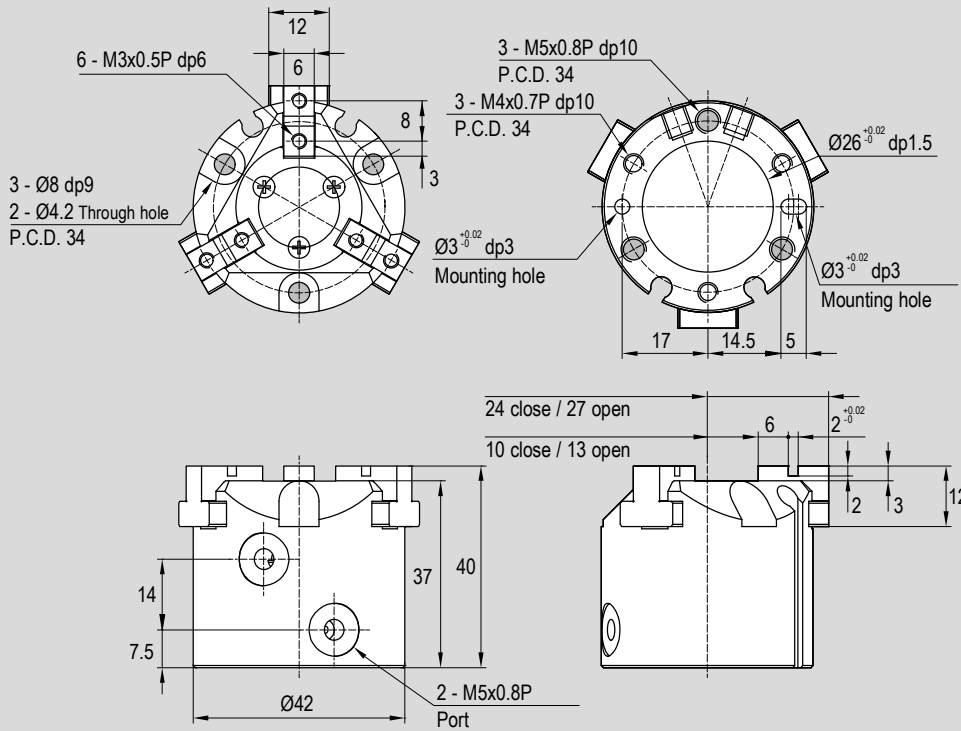

1 - CYLINDERS

Type: **PPE**
Ø 32

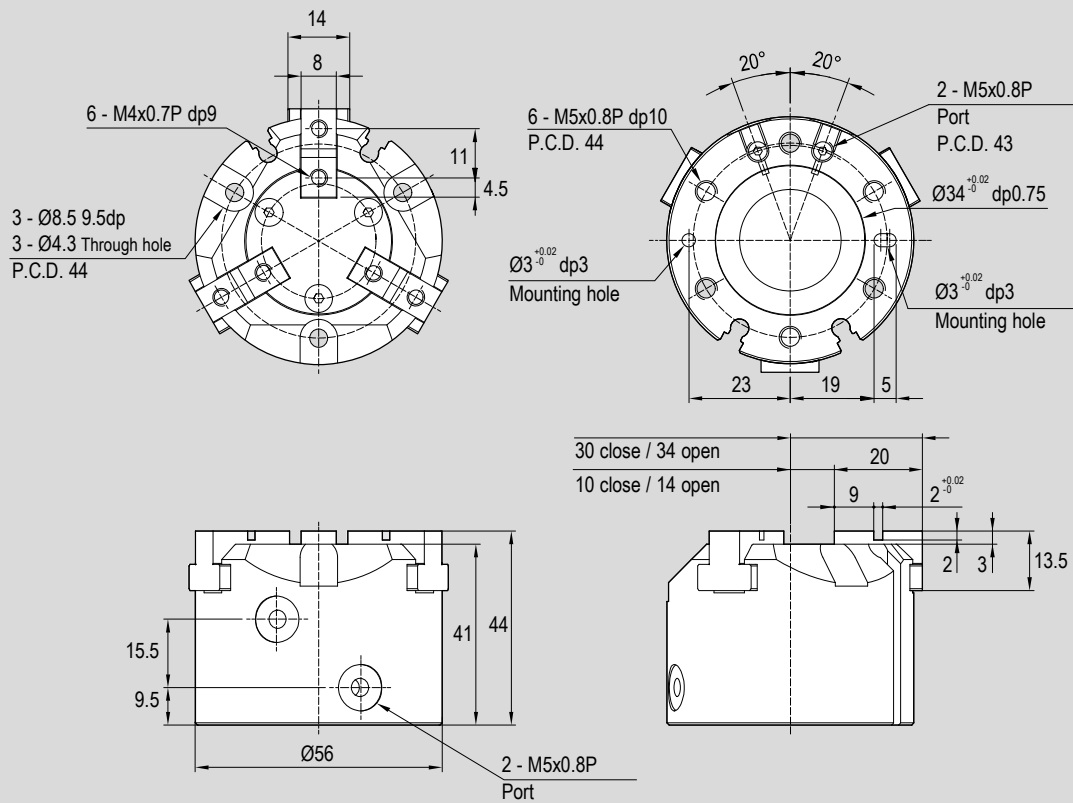

Standard dimensions

Type: PPE
Ø 40

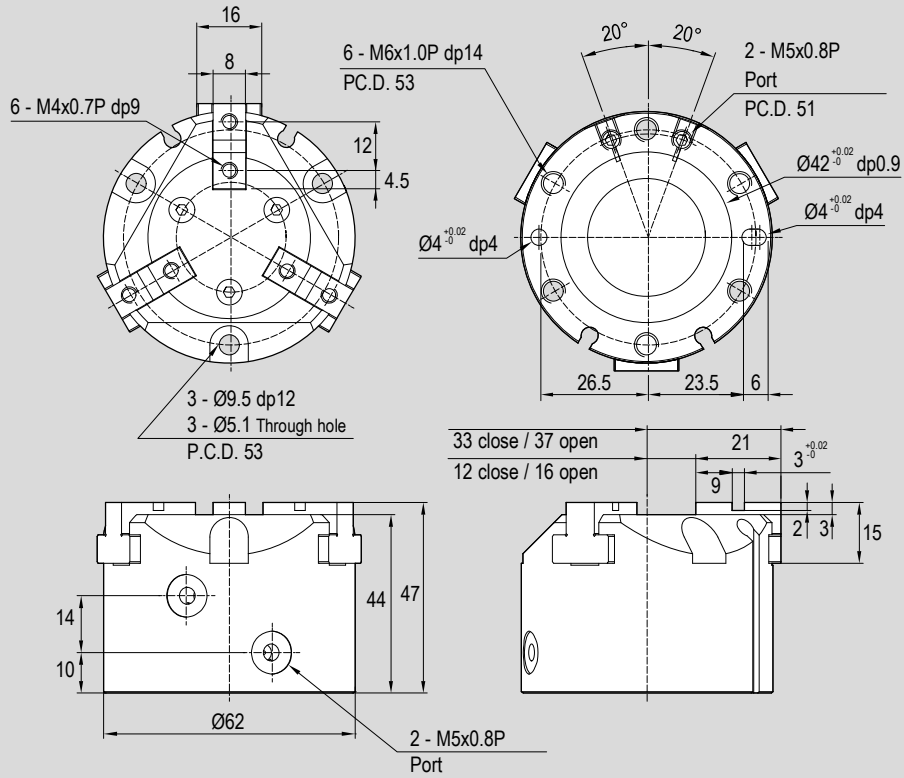

Type: PPE
Ø 50

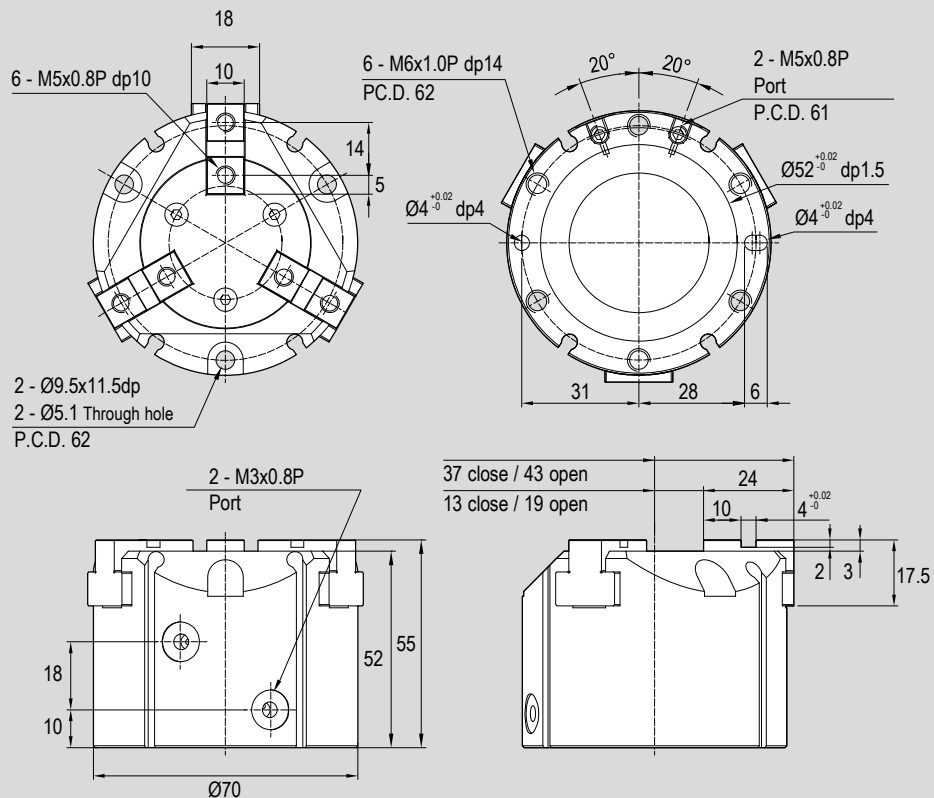

Standard dimensions

Type: **PPE**
Ø 63

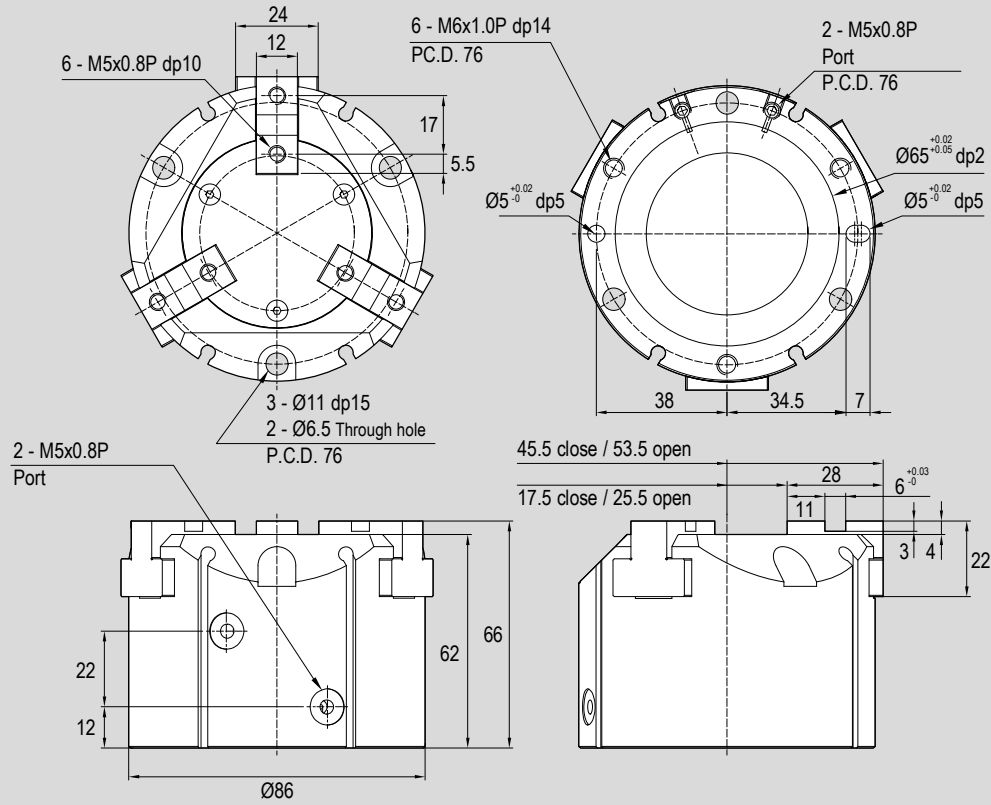

1 - CYLINDERS

Type: **PPE**
Ø 80

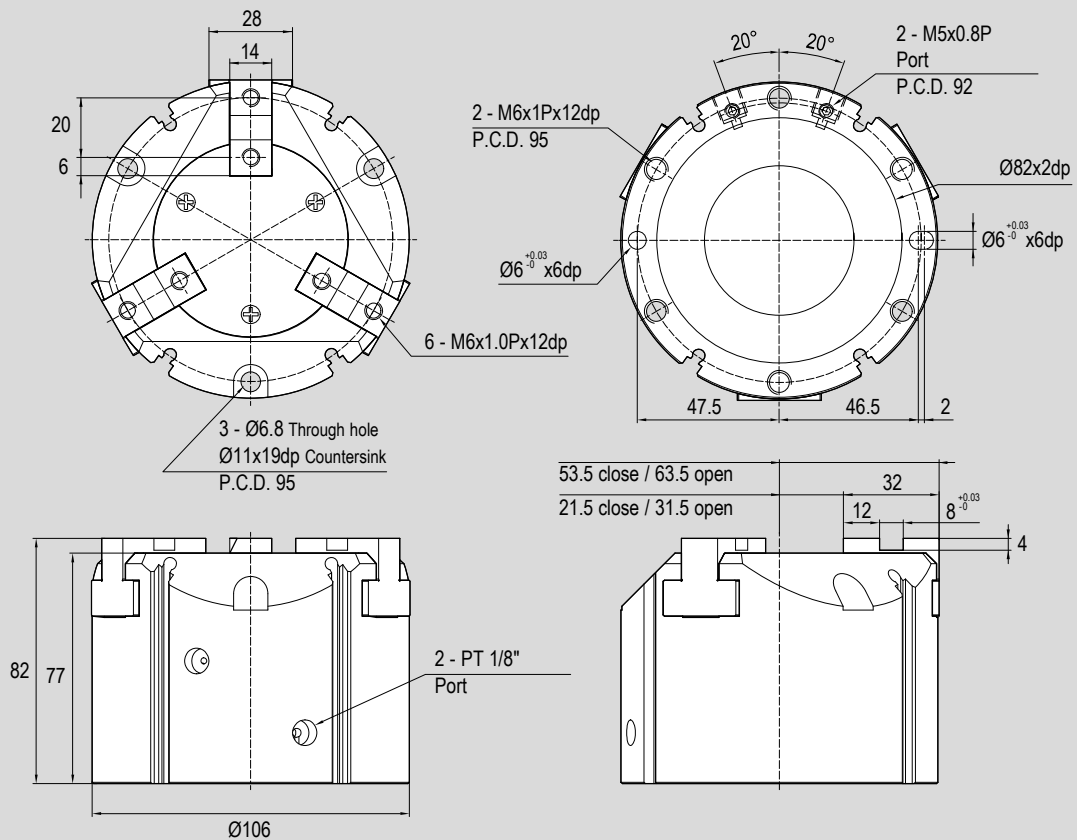

Standard dimensions

1 - CYLINDERS

Type: PPE
Ø 100

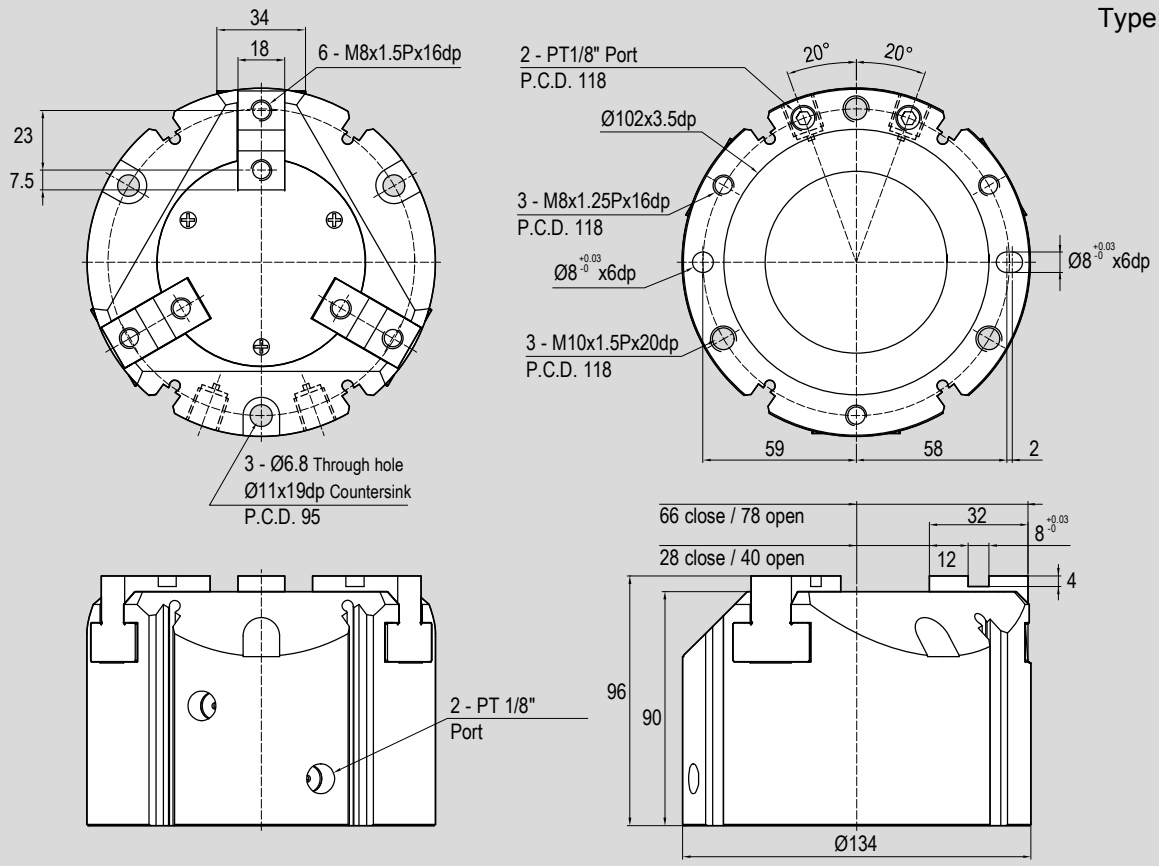

Male mounting for hand grips ..PM

	For cylinder Ø mm	Code	Item	Matching
	10	170655	10PM	PAB PAC PPB
	12	170665	12PM	
	16	075058	16PM	
	20	075059	20PM	
	25	075064	25PM	
	32	075065	32PM	

Female mounting for hand grips ..PF



	For cylinder Ø mm	Code	Item	Matching
	10	170656	10PF	PAB PAC PPB PPC
	12	170666	12PF	
	16	075066	16PF	
	20	075067	20PF	
	25	075068	25PF	
	32	075069	32PF	

Plate for 3 fingers hand grips ..PTD

	For cylinder Ø mm	Code	Item	Matching
	25	170657	25PTD	PPE
	32	170658	32PTD	
	40	170659	40PTD	
	50	170660	50PTD	
	63	170661	63PTD	
	80	170662	80PTD	
100	170663	100PTD		

Magnetic reed switch C groove ASC..

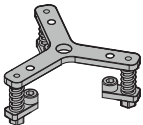
	For cylinder Ø mm	Code	Item	Matching
	6 ÷ 100	070248 	ASC1C525	PAB - PAC PPB - PPC PPD - PPE
		070249	ASC7N2M8	
		070382	ASC7M2M8	

SLIDE UNITS

for Cylinders



Find out our
key products



Solution for most applications



Easy and intuitive choice



Excellent value for money



Wide availability



Fast delivery



Features and certifications

Series of linear slide units for cylinders conforming to standard ISO 6432 and ISO 15552 possible to be fixed on four sides. These components are used with heavy loads to guarantee a better linearity of movement and a higher precision. Sometimes they can be used as anti-rotating devices too. Available in three types with different features. The versions with spherical bearing slides are better, but they can support lower loads than the versions with sintered bronze bushings. U-shaped versions, on the other hand, can support lower loads than the H-shaped. Supplied as standard in compliance with Reach and RoHS directives. On request they also can be supplied according to 2014/34/EU ATEX Directive.



Slide Units for Cylinders ISO 6432 type UGLB

from page 1.70.10



U-shaped linear slide units with sintered bronze bushings, for cylinders ISO 6432, possible to be fixed on four sides. These components are used with heavy loads to guarantee a better linearity of movement and a higher precision. Sometimes they can be used as anti-rotating devices too. On request they also can be supplied according to ATEX Directive.

Slide Units for Cylinders ISO 6432 type UGPB

from page 1.70.10



H-shaped linear slide units with sintered bronze bushings, for cylinders ISO 6432, possible to be fixed on four sides. These components are used with heavy loads to guarantee a better linearity of movement and a higher precision. Sometimes they can be used as anti-rotating devices too. On request they also can be supplied according to ATEX Directive.

Slide Units for Cylinders ISO 6432 type UGPS

from page 1.70.10



H-shaped linear slide units with spherical bearings, for cylinders ISO 6432, possible to be fixed on four sides. These components are used with heavy loads to guarantee a better linearity of movement and a higher precision. Sometimes they can be used as anti-rotating devices too.

Slide Units for Cylinders ISO 15552 type UGLB

from page 1.70.20



U-shaped linear slide units with sintered bronze bushings, for cylinders ISO 15552, possible to be fixed on four sides. These components are used with heavy loads to guarantee a better linearity of movement and a higher precision. Sometimes they can be used as anti-rotating devices too. On request they also can be supplied according to ATEX Directive.

Slide Units for Cylinders ISO 15552 type UGPB

from page 1.70.20



H-shaped linear slide units with sintered bronze bushings, for cylinders ISO 15552, possible to be fixed on four sides. These components are used with heavy loads to guarantee a better linearity of movement and a higher precision. Sometimes they can be used as anti-rotating devices too. On request they also can be supplied according to ATEX Directive.

Slide Units for Cylinders ISO 15552 type UGPS

from page 1.70.20



H-shaped linear slide units with spherical bearings, for cylinders ISO 15552, possible to be fixed on four sides. These components are used with heavy loads to guarantee a better linearity of movement and a higher precision. Sometimes they can be used as anti-rotating devices too.

Options

Description	Suffix
AISI 304 Stainless Steel rods (only for type UGLB and UGPB)	K
ATEX version on request (only for type UGLB and UGPB, option K required)	/ATEX
Special versions on request	/S

The options, when this is possible, can be combined with each other. For options matching and code key, see the tables below.

Options matching

Series	Bore	Model	Standard options matching	
			K	/ATEX⁽¹⁾
UGLB - UGPB	Ø 12 ÷ 100	Standard	●	●
		Stainless Steel Rods (K)		●
UGPS	Ø 12 ÷ 100	Standard	-	-

Key

● allowed matching; - not allowed matching

(1) For **/ATEX** versions, Stainless Steel Rod (option **K**) is required

Code key

Type	Cylinder bore	/	Cylinder stroke	Options	/	ATEX versions	Special versions
UGPB	20	/	200	K	/		
UGLB	Ø 12, 16, 20, 25 Slide Units for Cylinders ISO 6432		10 mm ÷ 2500 mm Stroke max. 1000 mm (Slide Unit for cylinders ISO 6432)	K*		ATEX* II 2G Ex h IIC T5 Gb II 2D Ex h IIIC T100°C Db	S
UGPB	Ø 32, 40, 50, 63, 80, 100 Slide Units for Cylinders ISO 15552		Stroke max. 2500 mm (Slide Unit for cylinders ISO 15552)	* Only for type UGLB - UGPB			
UGPS							

How to order

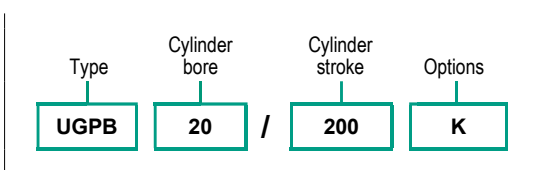

Notes

For further information on options and their matching, see tables above.
 For further information on the ATEX 2014/34/EU Directive, on classifications and protections, see from page III.1

Standard materials

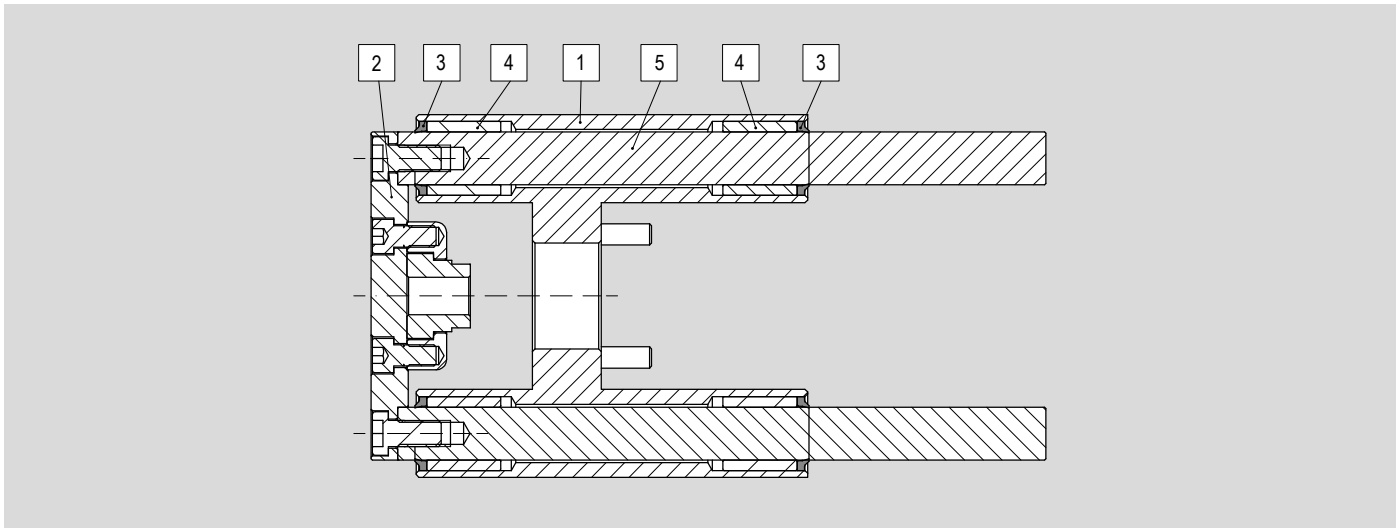

Position	Description	Materials		
		UGLB	UGPB	UGPS
1	Body	Anodised aluminium		
2	Plate	Anodised aluminium		
3	Seals	Polyurethane (PU)		
4	Bushings	Sintered bronze		Spherical bearings
5	Rods	Chrome-plated C45 steel		Hardened and chrome-plated CF51 Steel

Accessories

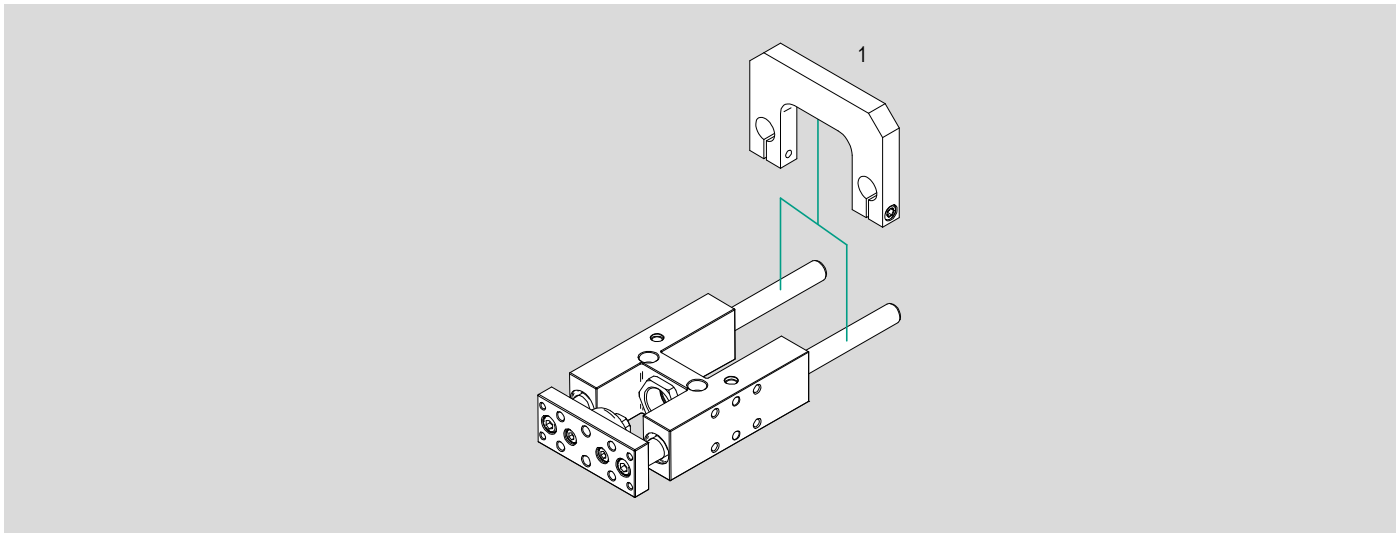

N.	Slide Unit bore	Item	Description	Matching			Code page	Data sheet page
				UGLB	UGPB	UGPS		
1	Ø 32 ÷ 100	SCSG	Connecting bracket for rods	●	●	●	1.70.50	1.100.400

Key
 ● allowed matching; - not allowed matching

Main features

12 ÷ 25

Bores Ø

UGLB

Type



12 ÷ 25

Bores Ø

UGPB

Type



12 ÷ 25

Bores Ø

UGPS

Type



Technical data

Type	UGLB	UGPB	UGPS
Description	U-shaped (for light loads) with sintered bronze bushings	H-shaped (for heavy loads) with sintered bronze bushings	H-shaped (for heavy loads) with spherical bearings
Bores	Ø 12 ÷ Ø 25		
Strokes	10 ÷ 1000 mm		
Temperature	-20°C ÷ +70°C		

Standard strokes

Stroke mm	UGLB Bore Ø mm			
	12	16	20	25
10				
25				
50				
80				
100				
125				
160				
200				
250				
320				
400				
500				

Stroke mm	UGPB - UGPS Bore Ø mm			
	12	16	20	25
10				
25				
50				
80				
100				
125				
160				
200				
250				
320				
400				
500				

Key
 Standard stroke

Standard dimensions

Type: **UGLB**
Ø 12 ÷ 16

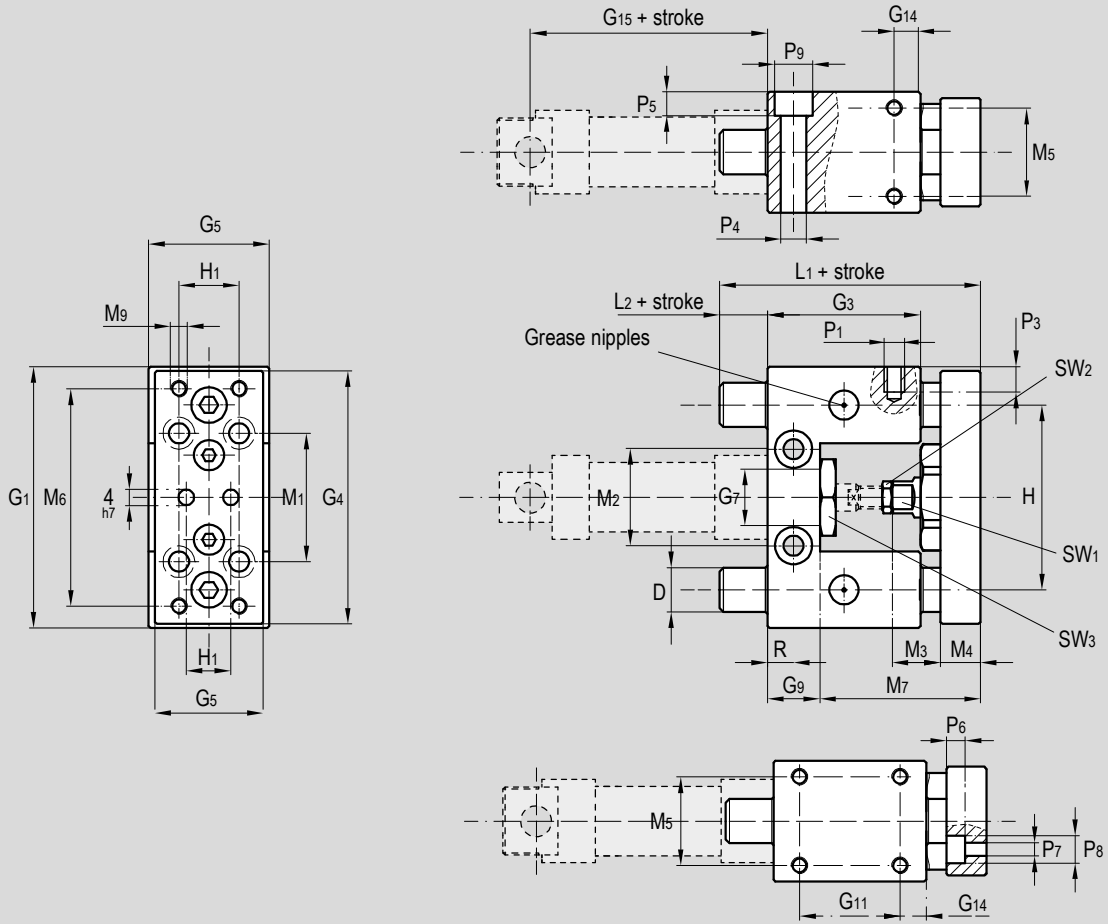

Ø (mm)	D	G ₁	G ₂	G ₃	G ₄	G ₅	G ₇	G ₉	G ₁₁	G ₁₄	G ₁₅	H	H ₁	L ₁	L ₂	M ₁	M ₂	M ₃
12	10	65	30	38	63	27	16	13	25	6,5	53	46	32	74	10	32	24	12
16	10	65	30	38	63	27	16	13	25	6,5	60	46	32	74	10	32	24	12

Ø (mm)	M ₄	M ₅	M ₆	M ₇	M ₉	P ₁	P ₂	P ₃	P ₄	P ₅	P ₆	P ₇	P ₈	P ₉	R	SW ₁	SW ₂	SW ₃
12	10	22	54	51	M4	M4	15	8	5,2	5,5	4,5	4,5	7	8,5	6,5	8	10	19
16	12	22	54	51	M4	M4	15	8	5,2	5,5	4,5	4,5	7	8,5	6,5	8	10	19

Standard dimensions

Type: **UGLB**
Ø 20 ÷ 25

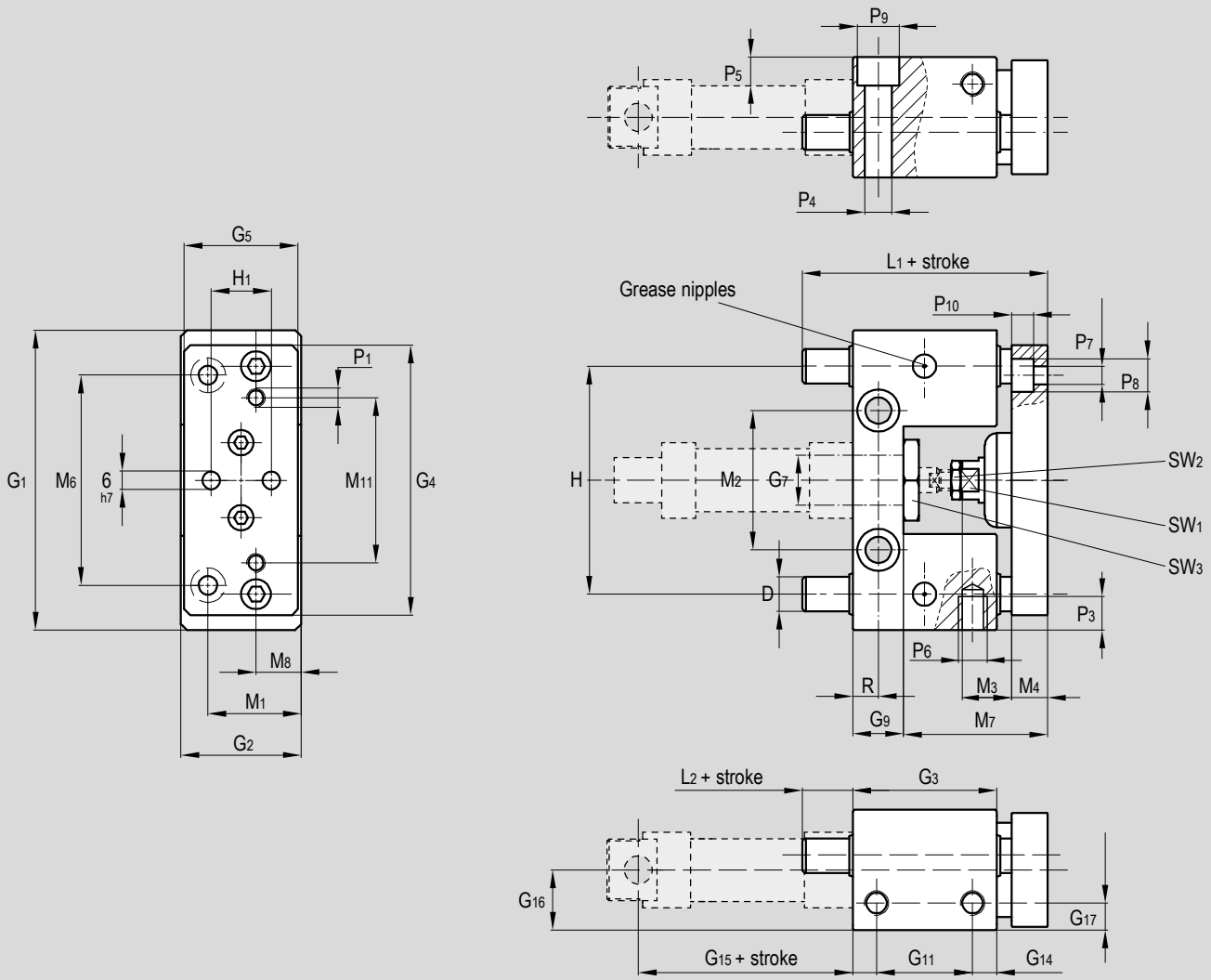

Ø (mm)	D	G ₁	G ₂	G ₃	G ₄	G ₅	ØG ₇	G ₉	G ₁₁	G ₁₄	G ₁₅	G ₁₆	G ₁₇	H	H ₁	R	M ₁	M ₂	M ₃
20	12	100	40	48	90	38	22	17	32	8	71	24	10	76	20	8,5	30	46,5	19
25	12	100	40	48	90	38	22	17	32	8	76	24	10	76	20	8,5	30	46,5	19

Ø (mm)	M ₄	M ₆	M ₇	M ₈	M ₁₁	L ₁	L ₂	ØP ₁	P ₃	ØP ₄	P ₅	ØP ₆	ØP ₇	ØP ₈	ØP ₉	P ₁₀	SW ₁	SW ₂	SW ₃
20	12	70	48	15	55	75	12	M6	15	9	9	M8	6,5	11	14	7	13	13	27
25	12	70	54	15	55	83	12	M6	15	9	9	M8	6,5	11	14	7	13	17	27

1 - CYLINDERS

Standard dimensions

Type: **UGPB, UGPS**

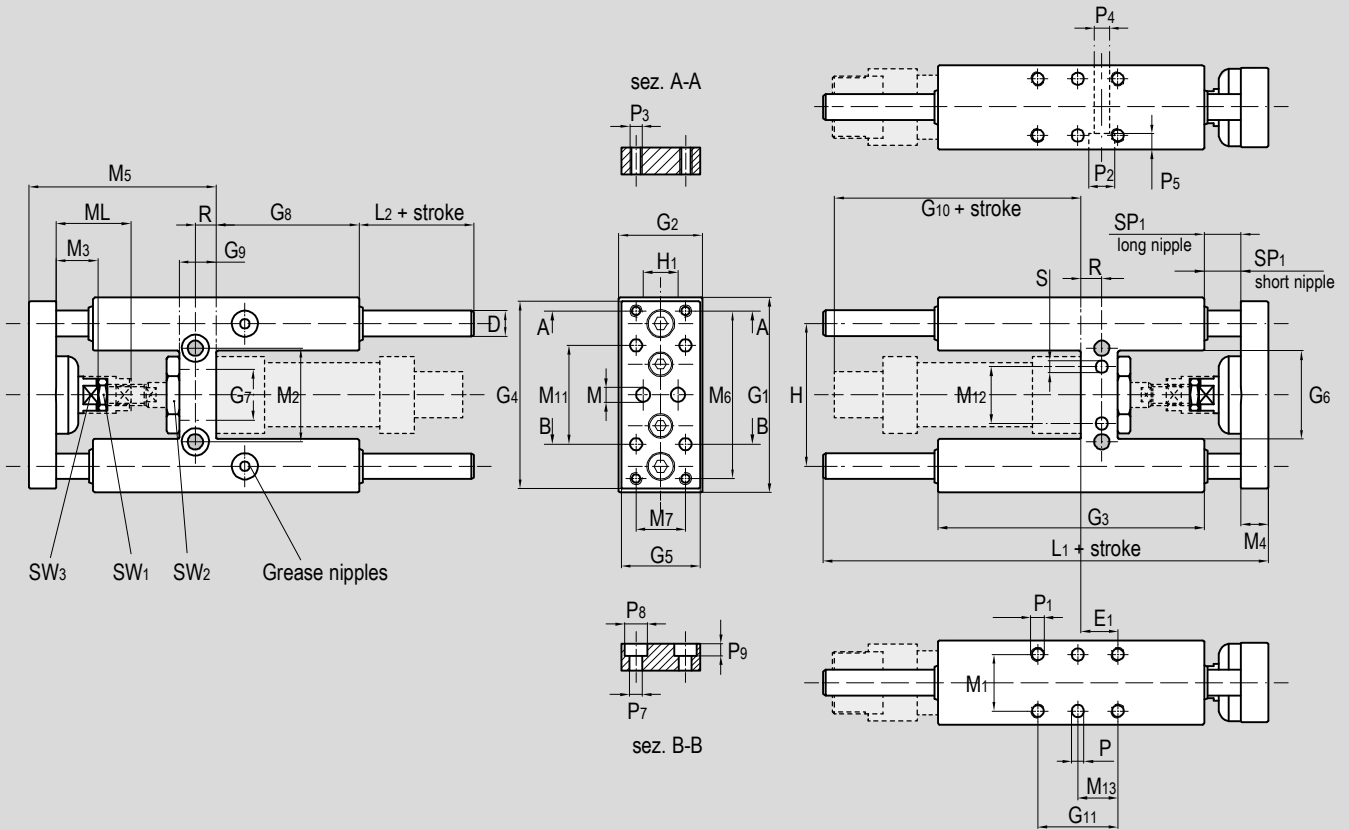

\varnothing (mm)	D	E_1	G_1	G_2	G_3	G_4	G_5	G_6	G_7	G_8	G_9	G_{10}	G_{11}	H	H_1	L_1	L_2	M_1	M_2	M_3	M_4	M_5	M_6
12	10	11	65	30	75	63	27	27	16	37	13	66	32,5	46	15	125	37	22	24	12	10	51	54
16	10	11	65	30	75	63	27	27	16	37	13	71	32,5	46	15	125	37	22	24	12	10	51	54
20	12	15	79	34	108	76	32	36	22	58	15	87	32,5	58	20	160	37	23	38	18	12	65	68
25	12	15	79	34	108	76	32	36	22	58	15	90	32,5	58	20	160	37	23	38	18	12	65	68

\varnothing (mm)	M_7	M_{h7}	M_{11}	M_{12}	M_{13}	ML	P_1	P_2	P_3	P_4	P_5	P_7	P_8	P_9	P_{h7}	S_{h7}	R	SP	SP_1	SW_1	SW_2	SW_3
12	15	4	32	/	16,25	/	M4	8,5	M4	5,5	5,5	4,5	7	4,5	-	-	6,5	3	3	10	19	8
16	15	4	32	/	16,25	/	M4	8,5	M4	5,5	5,5	4,5	7	4,5	-	-	6,5	3	3	10	19	8
20	20	6	40	23	16,25	40	M6	10,5	M5	6,5	7	5,5	9	6	5	5	8,5	3	22	13	27	13
25	20	6	40	23	16,25	40	M6	10,5	M5	6,5	7	5,5	9	6	5	5	8,5	3	22	17	27	13

Allowed load

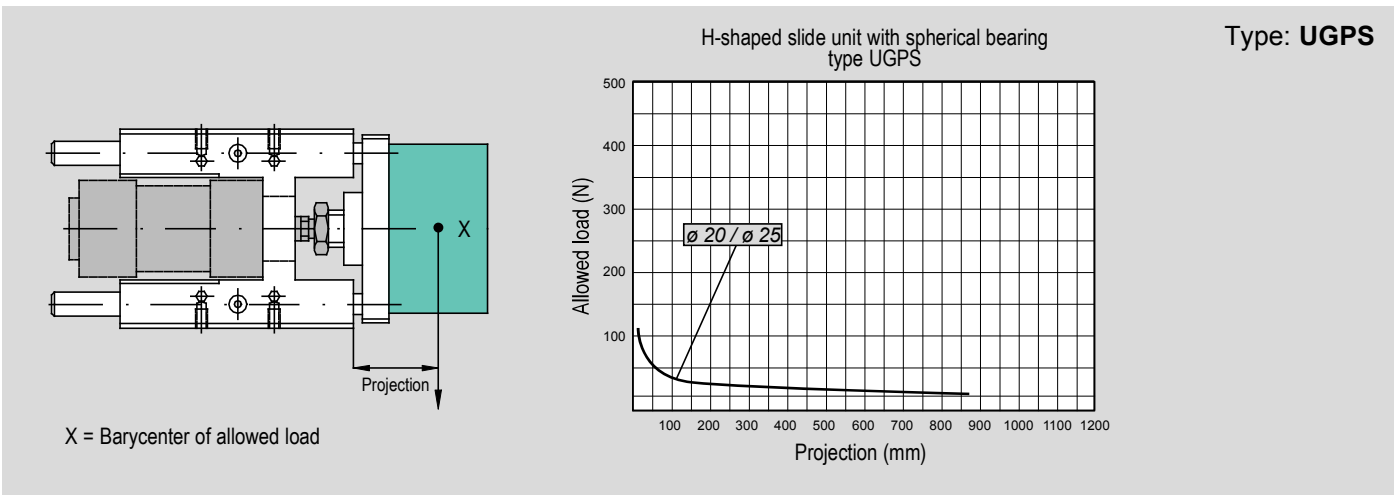
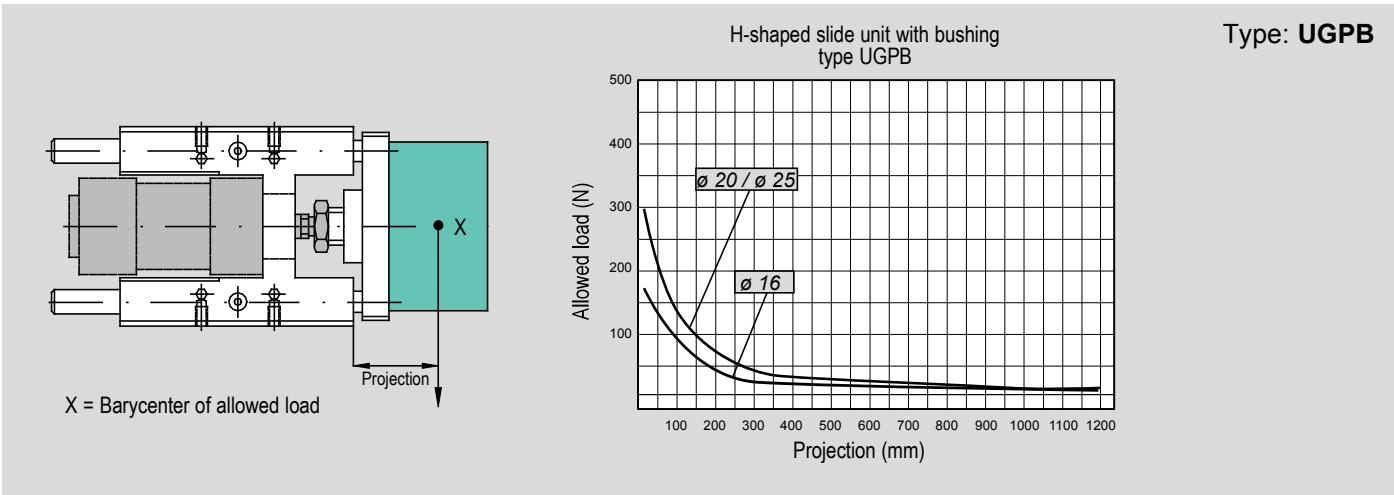
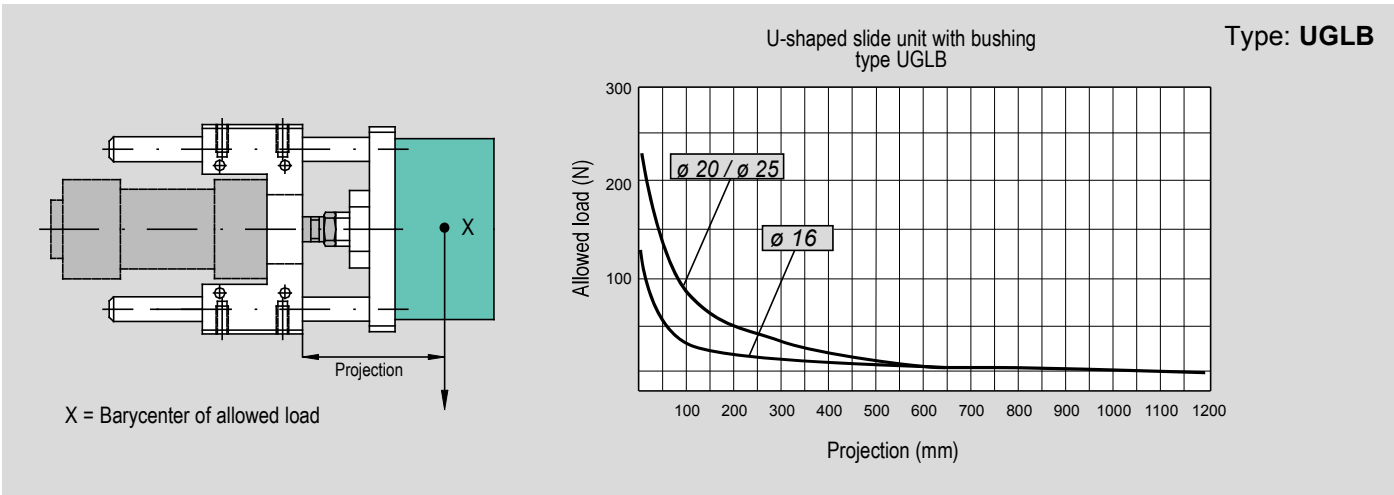

Main features

32 ÷ 100

Bores Ø

UGLB

Type



32 ÷ 100

Bores Ø

UGPB

Type

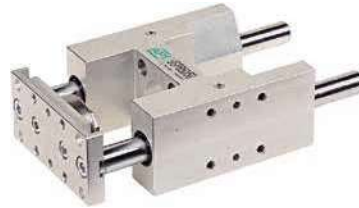

32 ÷ 100

Bores Ø

UGPS

Type



Technical data

Type	UGLB	UGPB	UGPS
Description	U-shaped (for light loads) with sintered bronze bushings	H-shaped (for heavy loads) with sintered bronze bushings	H-shaped (for heavy loads) with spherical bearings
Bores	Ø 32 ÷ Ø 100		
Strokes	10 ÷ 2800 mm		
Temperature	-20°C ÷ +80°C		

Standard strokes

Stroke mm	UGLB Bore Ø mm					
	32	40	50	63	80	100
25						
50						
80						
100						
125						
160						
200						
250						
300						
320						
400						
500						

Stroke mm	UGPB - UGPS Bore Ø mm					
	32	40	50	63	80	100
25						
50						
80						
100						
125						
160						
200						
250						
300						
320						
400						
500						

Key
 Standard stroke

Standard dimensions

Type: **UGLB**

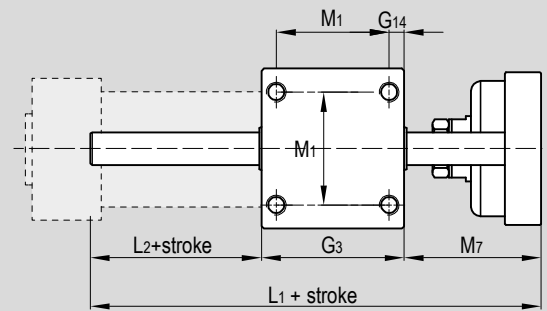
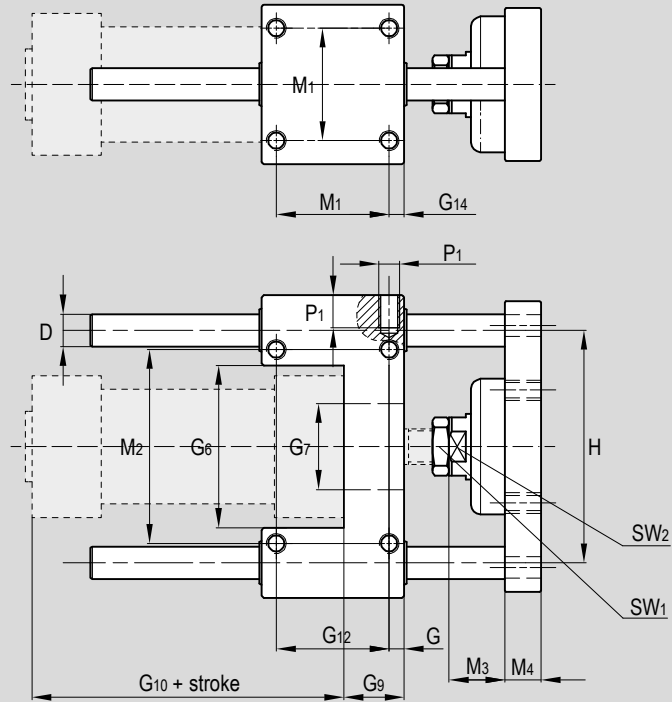
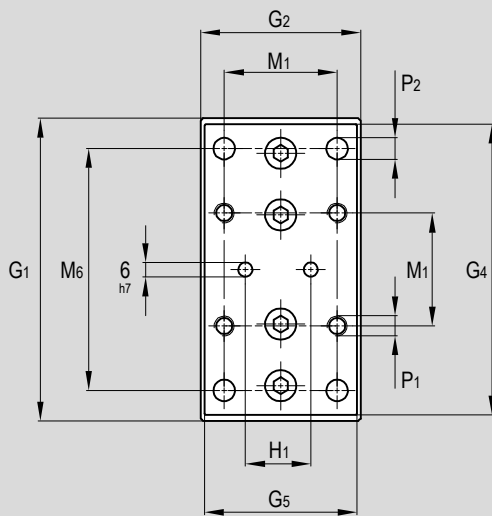

∅ (mm)	D	G	G ₁	G ₂	G ₃	G ₄	G ₅	G ₆	∅G ₇	G ₉	G ₁₀	G ₁₂	G ₁₄	H	H ₁	M ₁	M ₂	M ₃	M ₄	M ₆	M ₇	L ₁	L ₂	∅P ₁	P ₂	P ₃	SW ₁	SW ₂
32	12	7,8	100	48	48	95	45	48	30	17	94	32,5	7,8	74	31	32,5	58	23	11	78	46	108	14	M6	6,5	12	15	17
40	12	10	106	56	58	101	53	64	35	21	105	38	10	80	36	38	64	23	15	84	52	120	10	M6	6,5	12	15	17
50	16	6,3	125	66	59	120	63	67	40	25	106	46,5	6,3	96	45	46,5	80	24	15	100	65	130	6	M8	8,5	15	22	24
63	16	9,8	132	76	76	127	73	76	45	25	121	56,5	9,8	104	45	56,5	95	24	15	105	65	145	4	M8	8,5	15	22	24
80	20	20	165	98	90	160	95	97	45	34	128	50	9	130	56	72	130	30	16	130	71	170	9	M10	11	18	27	27
100	20	20	185	118	110	180	115	117	55	39	138	70	10,5	150	56	89	150	30	18	150	71	190	9	M10	11	18	27	27

Slide Units for Cylinders

Slide Units for Cylinders ISO 15552 series UGPB - UGPS



Standard dimensions

Type: UGPB, UGPS

1 - CYLINDERS

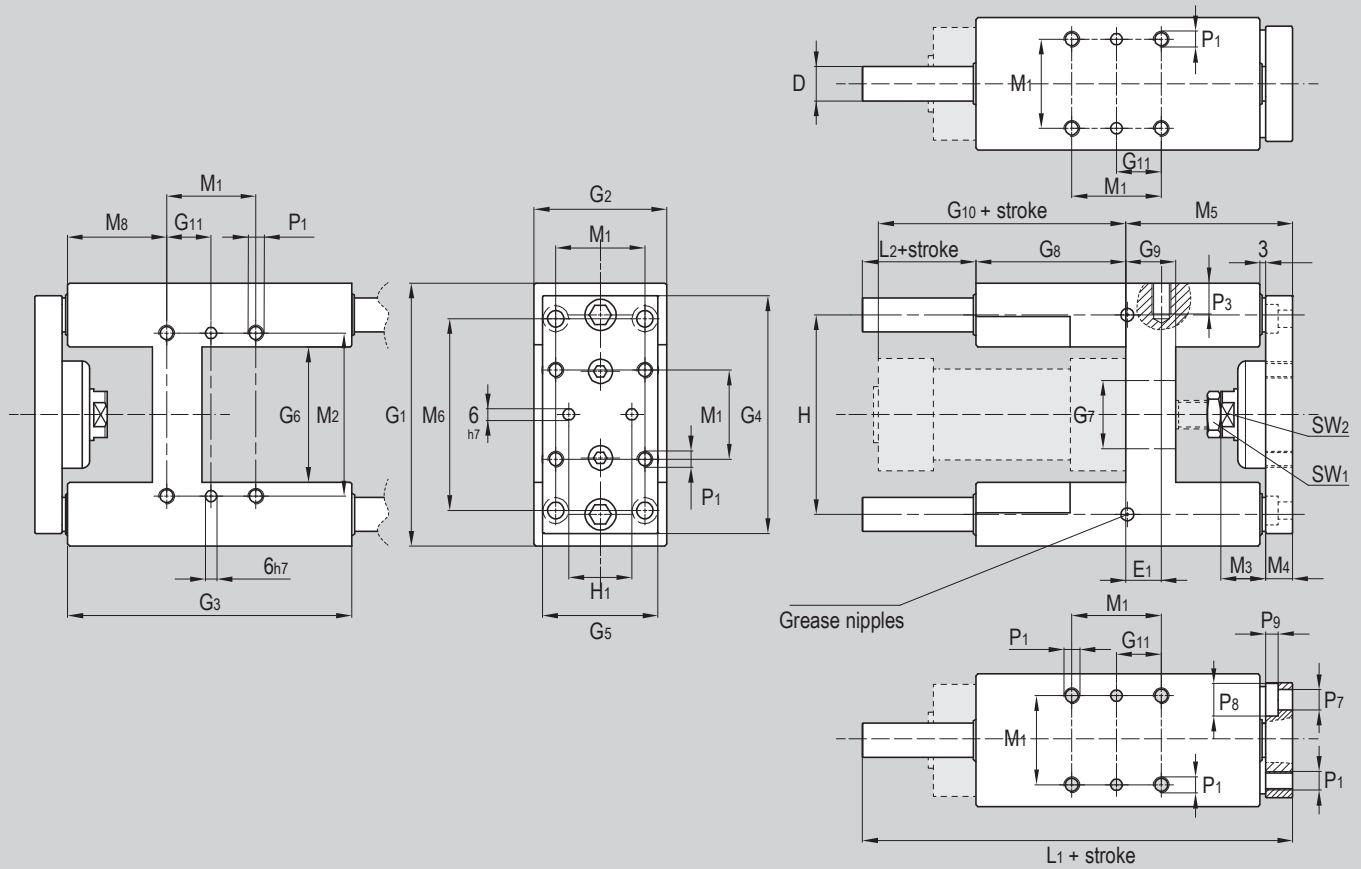

Ø (mm)	D	E ₁	G ₁	G ₂	G ₃	G ₄	G ₅	G ₆	ØG ₇	G ₈	G ₉	G ₁₀	G ₁₁	H	H ₁	M ₁	M ₂	M ₃	M ₄	M ₅	M ₆	M ₈	L ₁	L ₂	ØP ₁	P ₃	ØP ₇	ØP ₈	P ₉	SW ₁	SW ₂
32	12	4,3	97	49	125	90	45	50,2	30	76	17	94	16,25	74	31	32,5	61	23	11	63	78	44,5	177	38	M6	10	6,5	10,5	6,5	15	17
40	16	11	115	58	139	110	54	58,2	35	81	21	105	19	87	36	38	69	23	15	76	84	47	192	35	M6	10	6,5	10,5	6,5	15	17
50	20	18,8	137	69	148	124	60	70,2	40	78	26	106	23,25	104	45	46,5	85	24	15	88	100	51,5	205	39	M8	16	8,5	13,5	9	22	24
63	20	15,3	152	85	178	145	79	85,2	45	107	26	121	28,25	119	45	56,5	100	24	15	89	105	55,7	237	41	M8	16	8,5	13,5	9	22	24
80	25	21	189	105	215	180	99	106	45	128	34	128	36	148	56	72	130	30	20	110	130	66	280	42	M10	18	11	18	11	27	27
100	25	24,5	213	129	220	200	120	131	55	128	39	138	44,5	172	56	89	150	30	20	115	150	67,5	280	37	M10	18	11	18	11	27	27

Allowed load

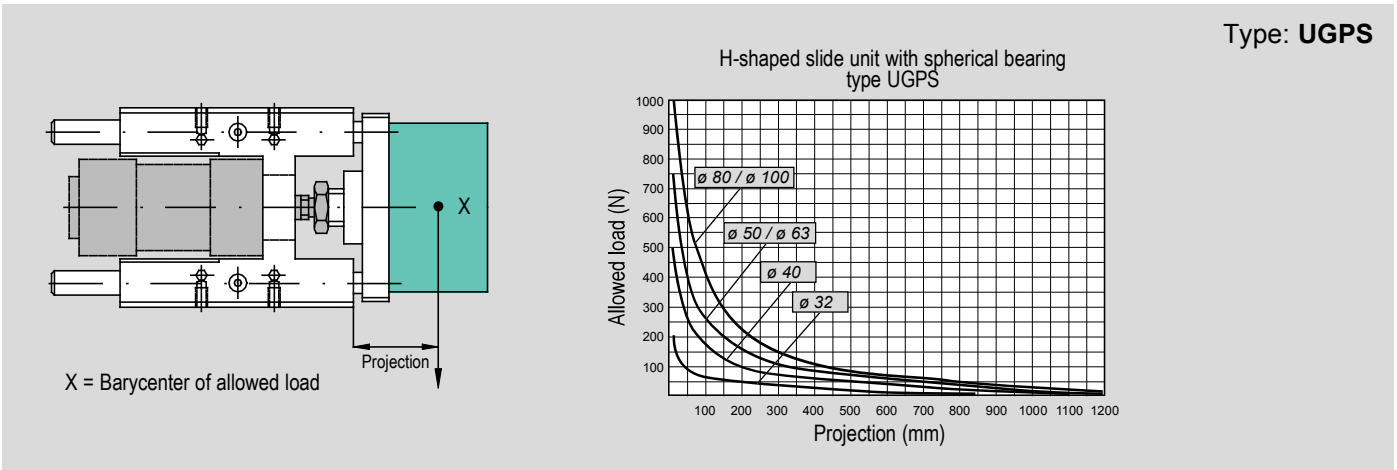
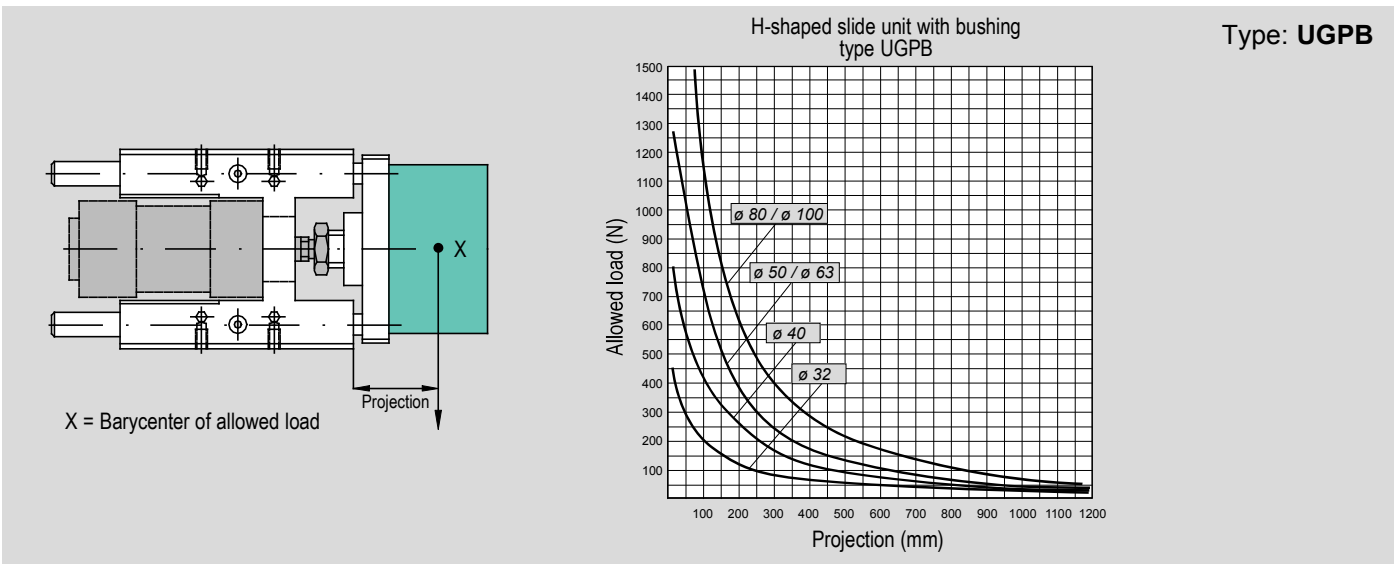
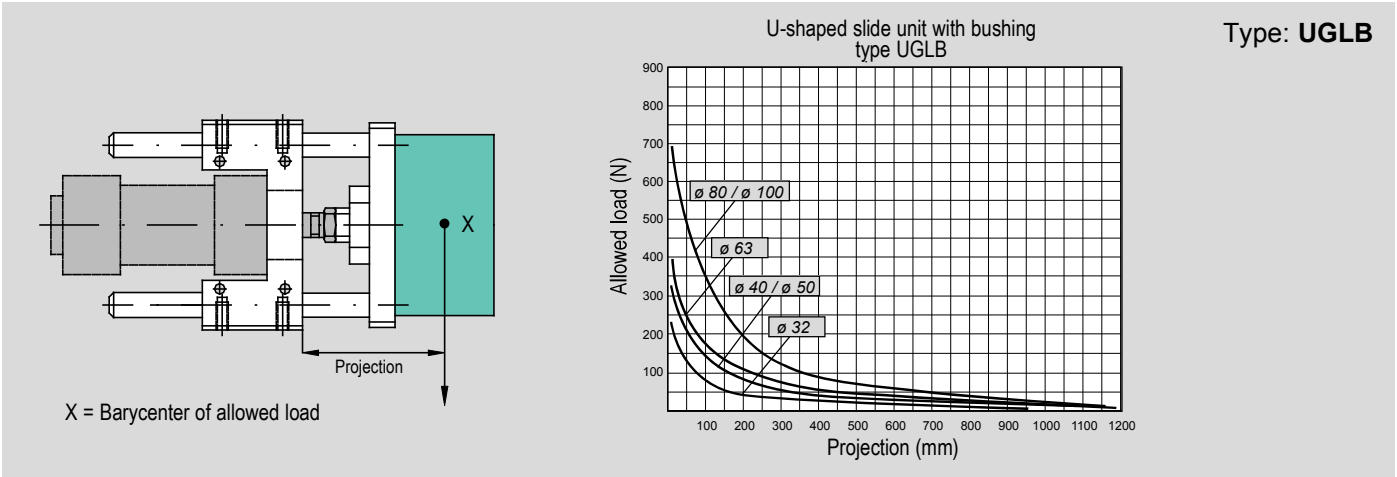

Connecting bracket for rods



	Per unità di guida Ø mm	Code	Item	Compliance
	32	077901	SCSG032	-
	40	077902	SCSG040	
	50	077903	SCSG050	
	63	077904	SCSG063	
	80	077905	SCSG080	
	100	077906	SCSG100	

PISTON ROD-BRAKE

for Cylinders



Find out our
key products



Solution for most applications



Easy and intuitive choice



Excellent value for money



Wide availability



Fast delivery



Features and certifications

Series of piston rod-brake for cylinders conforming to standard ISO 6432 and ISO 15552, suitable for blocking the rod of the cylinder in the event of a pressure lack or pressure drop to the cylinder, or in those cases where a stop is necessary for a processing or handling. Supplied as standard in compliance with Reach and RoHS directives.



Static piston rod-brake for cylinders ISO 6432 from page 1.75.10



Static piston rod-brake for cylinders conforming to standard ISO 6432. Can be supplied normally closed or normally open. The clamping forces are suitable for cylinder working pressure up to 8 bar and act in both directions. For the application of the piston rod-brake type ABS to a cylinder ISO 6432, the actuator must be ordered with the rod predisposed for this (extended rod in hardened and chrome plated steel, option B).

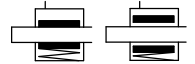

Static piston rod-brake for cylinders ISO 15552 from page 1.75.20



Static piston rod-brake for cylinders conforming to standard ISO 15552. Can be supplied normally closed or normally open. The clamping forces are suitable for cylinder working pressure up to 8 bar and act in both directions. For the application of the piston rod-brake type ABS to a cylinder ISO 15552, the actuator must be ordered with the rod predisposed for this (extended rod in hardened and chrome plated steel, option B).

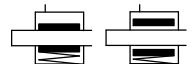



Dynamic piston rod-brake for cylinders ISO 15552 from page 1.75.40



Dynamic piston rod-brake for cylinders conforming to standard ISO 15552. Can be supplied normally closed only. The peculiarity of this type ABK is to lock the piston rod while moving and to hold it still even in presence of pressure in the chamber. The special feature of the piston-rod brake type ABK is the absolute absence of axial movement and rotation of the cylinders' piston-rod. For the application of the piston rod-brake type ABK to a cylinder ISO 15552, the actuator must be ordered with the rod predisposed for this (extended rod in hardened and chrome plated steel, option B1).



Standard options matching

Series	Bore	Model	Functions	
			Normally closed 	Normally open 
ABS..	Ø 20 + 125	Standard	●	●
ABK..	Ø 32 + 100	Standard	●	-

Key
 ● available; - not available.

Code key

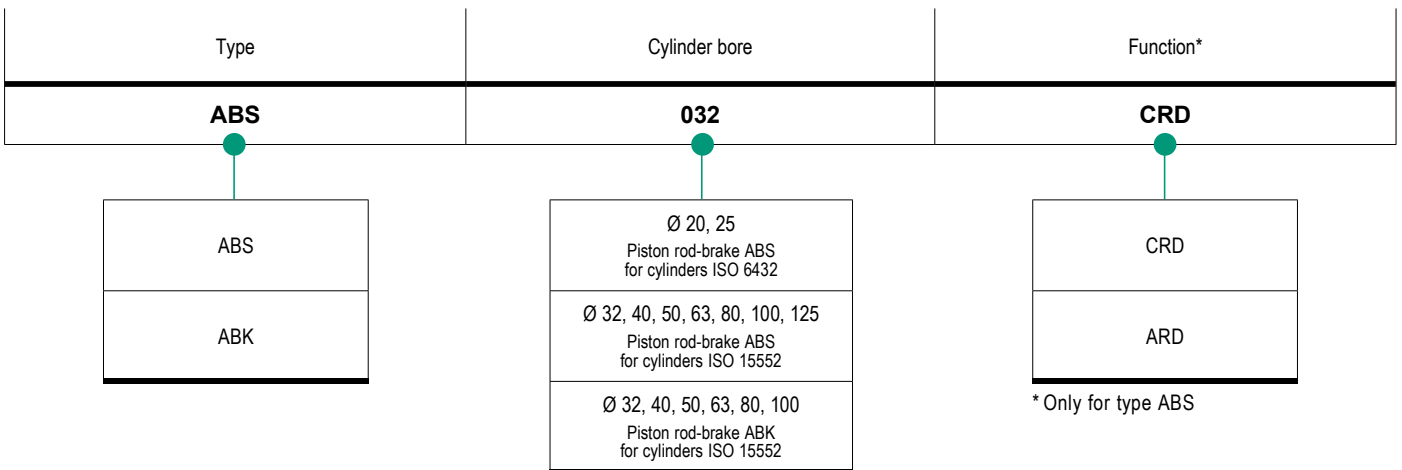

How to order type ABS

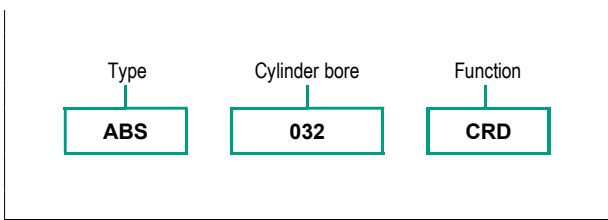

How to order type ABK

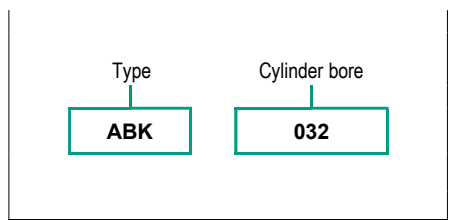

Standard materials

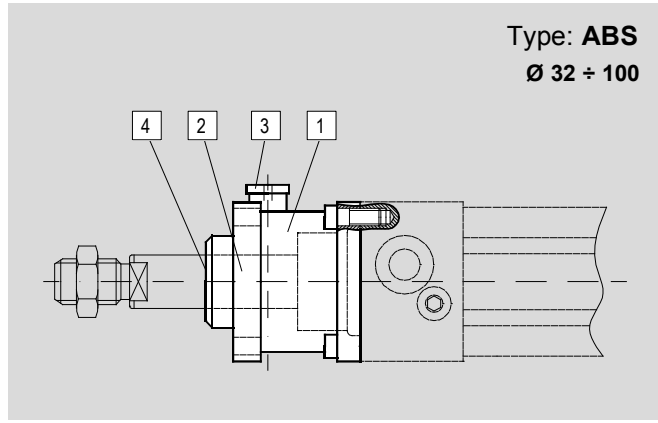
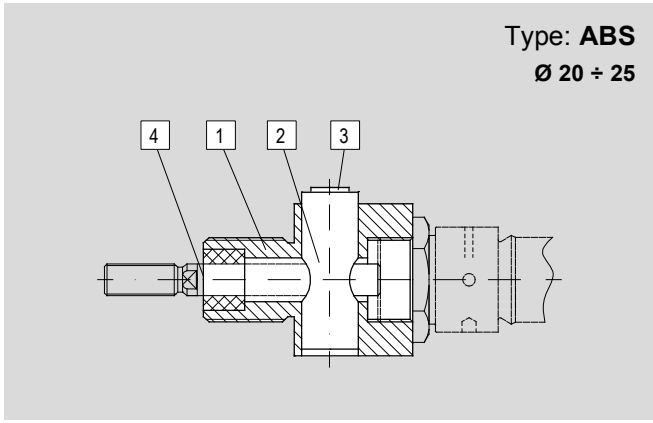

Position	Description	Materale
1	Body	Anodised aluminium
2	Jaws	Brass
3	Seals	NBR
4	Cylindrical locking device	Anodised aluminium

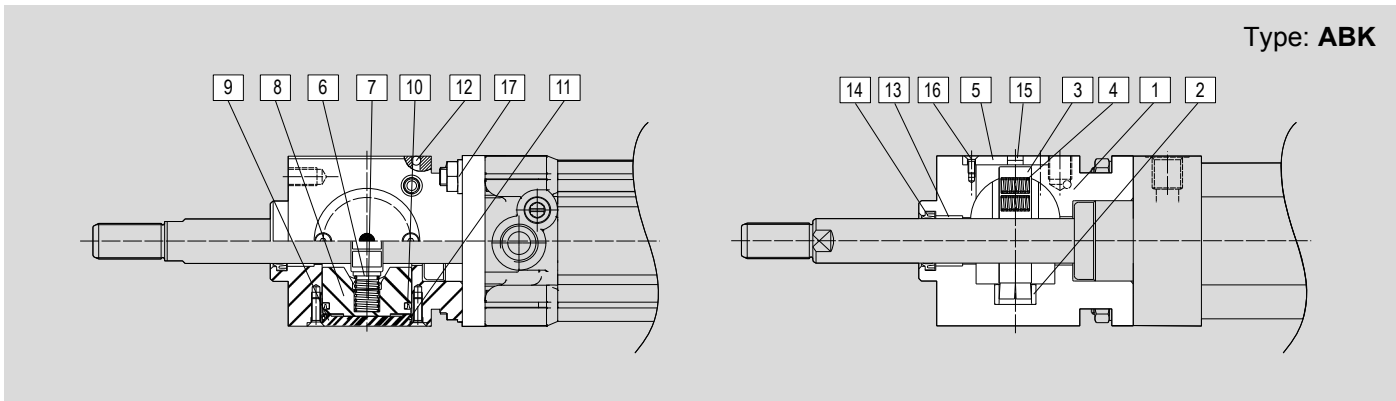

Position	Description	Materale
1	Body	Anodised aluminium
2	Bushing	Carbon steel
3	Locking unit	Brass
4	Spring	SWPA
5	Cover	Anodised aluminium
6	Locking spring	Acetalic resin (POM)
7	Spring	SWPA
8	Piston	Acetalic resin (POM)
9	Rear cover	Anodised aluminium
10	Seal	Polyurethane (PU)
11	O-ring	NBR
12	Sphere	Carbon steel
13	Bushing	Sintered bronze
14	Rod seal	NBR
15	Silencer	Brass
16	Screw	Nickel-plated carbon steel
17	Screw	Carbon steel blackening

Piston Rod-Brake for Cylinders

Static piston-rod brake for cylinders ISO 6432



Main features

20 ÷ 25

Bores Ø



Normally closed

ABS..CRD

Type



20 ÷ 25

Bores Ø



Normally open

ABS..ARD

Type

Technical data

Bore Ø (mm)	20	25
Fluid	Compressed filtered air with or without lubrication	
Pressure range	4 ÷ 8 bar	
Locking force (N)	300	400
Temperature range	-10°C ÷ +80°C	

Warning: working of piston rod-brake type ABS is static: before clamping is necessary to arrest the rod, is not usable for reducing the speed of the rod while moving. The locking-rod unit must only be unlocked when the pressures of both chambers of the cylinder are balanced, or the rod of the cylinder could move with non-uniform motion, causing problems to the application. For the application of the piston rod-brake the actuator must be ordered with the rod predisposed for this (extended rod in hardened and chrome plated steel, option B).

Standard dimensions

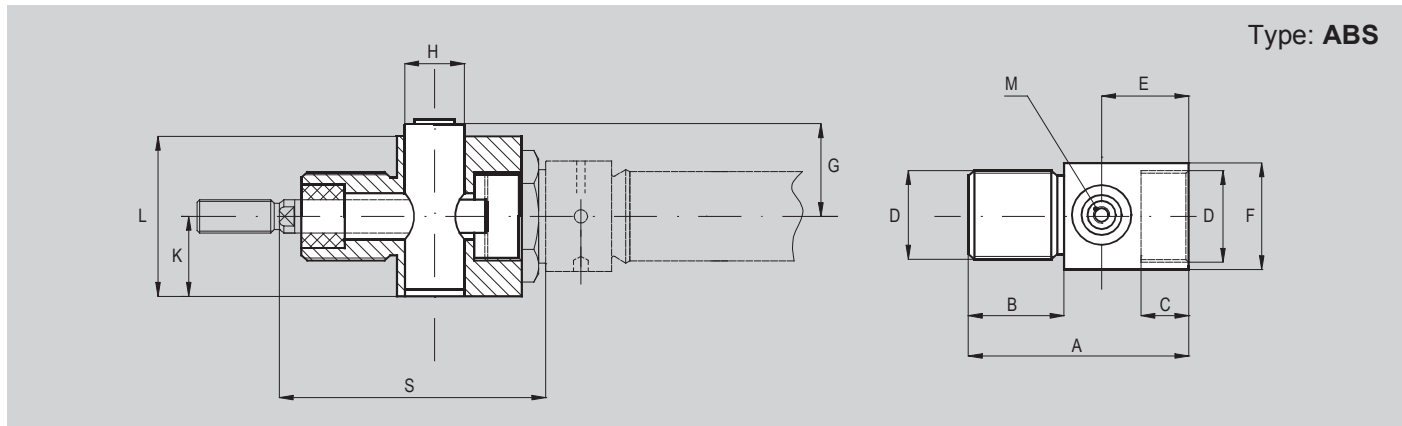

For cylinder Ø (mm)	A	B	C	E	F	G	H	K	D	L	M	S
20	58	23	12	24	27	21	20	19	M22x1,5	38	M5	72
25	58	23	12	24	27	21	20	19	M22x1,5	38	M5	74

Codes

For cylinder Ø (mm)	Code	Item	Function
20	042022	ABS020CRD	Normally closed
25	042023	ABS025CRD	

Seals kit not available

For cylinder Ø (mm)	Code	Item	Function
20	042032	ABS020ARD	Normally open
25	042033	ABS025ARD	

Seals kit not available

Piston Rod-Brake for Cylinders

Static piston-rod brake for cylinders ISO 15552



1 - CYLINDERS

Main features

32 ÷ 125

Bores Ø



Normally closed

ABS..CRD

Type



32 ÷ 125

Bores Ø



Normally open

ABS..ARD

Type

Technical data

Bore Ø (mm)	32	40	50	63	80	100	125
Fluid	Compressed filtered air with or without lubrication						
Pressure range	4 ÷ 8 bar						
Locking force (N)	650	1100	1600	2500	4000	6300	8700
Temperature range	-10°C ÷ +80°C						

Warning: working of piston rod-brake type ABS is static: before clamping is necessary to arrest the rod, is not usable for reducing the speed of the rod while moving. The locking-rod unit must only be unlocked when the pressures of both chambers of the cylinder are balanced, or the rod of the cylinder could move with non-uniform motion, causing problems to the application. For the application of the piston rod-brake the actuator must be ordered with the rod predisposed for this (extended rod in hardened and chrome plated steel, option B).

Codes

For cylinder Ø (mm)	Code	Item	Function
32	042001	ABS032CRD	Normally closed
40	042002	ABS040CRD	
50	042003	ABS050CRD	
63	042004	ABS063CRD	
80	042005	ABS080CRD	
100	042006	ABS100CRD	
125	042007	ABS125CRD	

Seals kit not available

For cylinder Ø (mm)	Code	Item	Function
32	042011	ABS032ARD	Normally open
40	042012	ABS040ARD	
50	042013	ABS050ARD	
63	042014	ABS063ARD	
80	042015	ABS080ARD	
100	042016	ABS100ARD	
125	042017	ABS125ARD	

Seals kit not available

Standard dimensions

Type: **ABS**

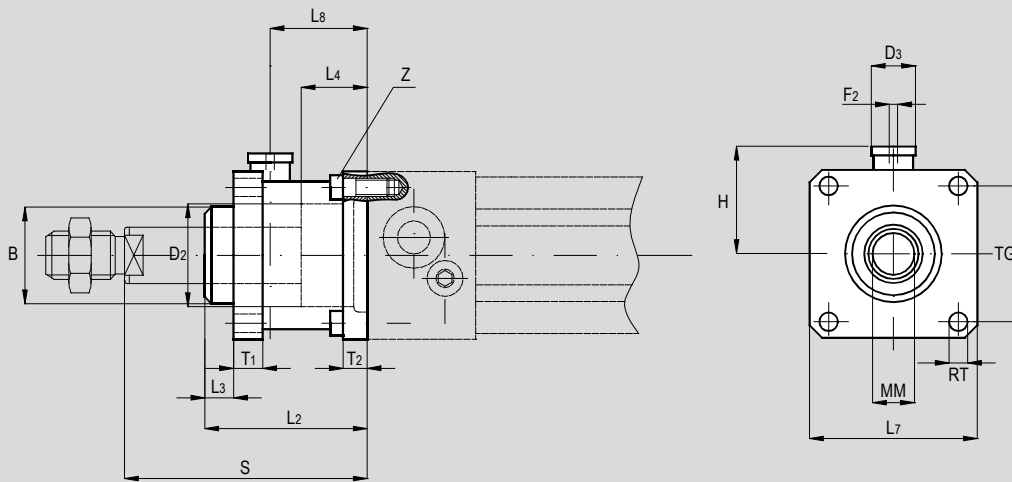

1 - CYLINDERS

Per cylinder Ø (mm)	ØB d11	ØD ₂	ØD ₃	F ₂	H	L ₂	L ₃	L ₄	L ₇	ØL ₈	ØMM	RT	T ₁	T ₂	TG	Z	S
32	30	30,5	20	M5	25,5	58	10	20,5	45	31,5	12	M6	13	8	32,5	M6x20	74
40	35	35	24	1/8"	30	65	10	22,5	50	36	16	M6	13	8	38	M6x20	85
50	40	40	30	1/8"	36	82	12	29,5	60	45,5	20	M8	16	15	46,5	M8x30	107
63	45	45	38	1/8"	40	82	12	29,5	70	49,5	20	M8	16	15	56,5	M8x30	107
80	45	45	48	1/8"	50	110	20	35	90	61	25	M10	20	18	72	M10x35	136
100	55	55	48	1/8"	58	115	23	39	105	65	25	M10	20	18	89	M10x35	143
125	60	60	65	1/8"	80	167	45	51	140	86,5	32	M12	30	22	110	M12x40	187

Piston Rod-Brake for Cylinders

Dynamic piston-rod brake for cylinders ISO 15552



Main features

32 ÷ 100

Bores Ø



Normally closed

ABK

Type



Technical data

Bore Ø (mm)	32	40	50	63	80	100	
Fluid	Compressed filtered air with or without lubrication						
Pressure range	4 ÷ 6,5 bar						
Minimum working pressure (bar)	4.0	4.0	3.5	3.5	3.0	3.0	
Locking model	Secure locking of piston rod in any position						
Locking force (N)	510	860	1275	2060	3300	4620	
Lock braking precision (mm)	V (mm/sec)	(Horizontal axis) operate with a load ratio of 70% or less (Vertical axis) operate with a load ratio of 35% or less					
	50 (mm/sec)	±0.7	±0.8	±0.9	±0.8	±0.8	±1
	100 (mm/sec)	±1	±1	±1	±1	±1.2	±1.4
	200 (mm/sec)	±1.3	±1.6	±1.4	±1.8	±2.1	±2.4
Allowable energy (max) J(N · m) J(Ek=½mv ²)	0.84	1.41	2.2	3.31	4.98	7.57	
Temperature range	-10°C ÷ +60°C						

Warning: for the application of the piston rod-brake the actuator must be ordered with the rod predisposed for this (extended rod in hardened and chrome plated steel, option B1).

Codes

For cylinder Ø (mm)	Code	Item	Option
32	042035	ABK032	Normally closed
40	042036	ABK040	
50	042037	ABK050	
63	042038	ABK063	
80	042039	ABK080	
100	042040	ABK100	

Standard dimensions

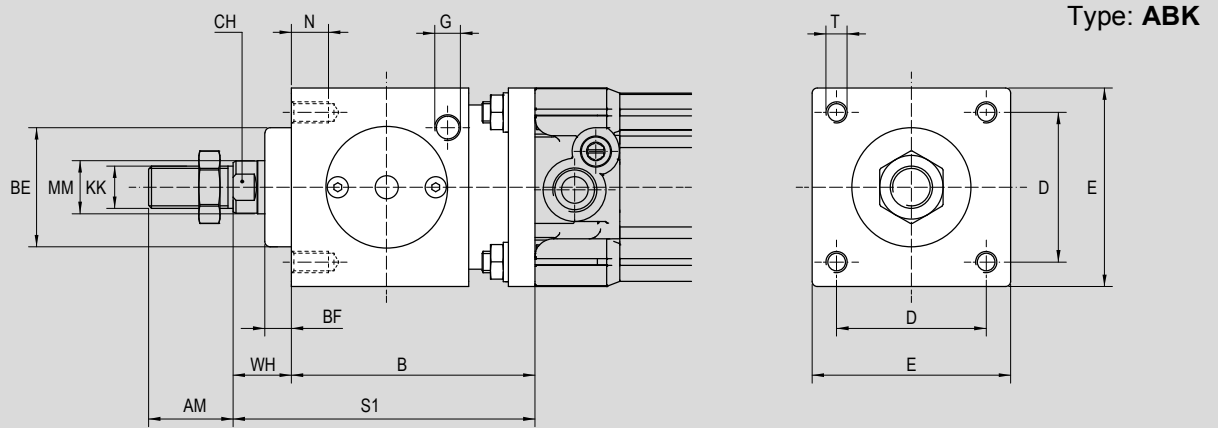

For cylinders Ø (mm)	AM	B	BE	BF	CH	D	E	G	ØKK	ØMM f7	N	S1	T	WH
32	22	73	30	8	10	32.5	47	1/8"	M10x1.25	12	12	99	M6	26
40	24	76	35	8	13	38	53	1/8"	M12x1.25	16	12	106	M6	30
50	32	90	40	8	17	46.5	65	1/8"	M16x1.5	20	14	127	M8	37
63	32	92	45	10	17	56.5	75	1/8"	M16x1.5	20	14	129	M8	37
80	40	110	45	10	22	72	95	1/4"	M20x1.5	25	16	156	M10	46
100	40	130	55	10	27	89	115	1/4"	M20x1.5	25	16	181	M10	51

Horizontal application

Type: **ABK**

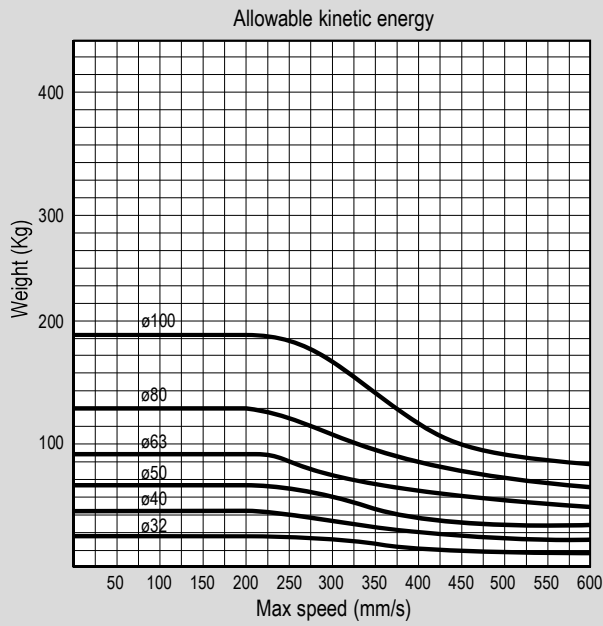
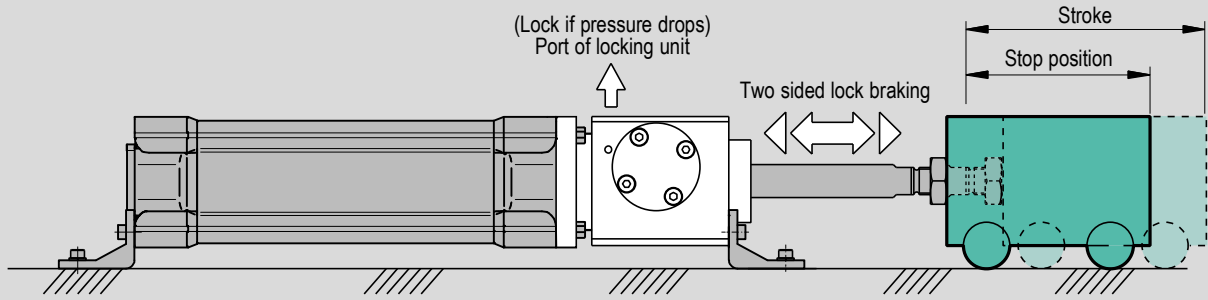

$$Ek = \frac{1}{2} mv^2$$

Ek: Kinetic energy (J)
v: Speed (m/s)
m: Weight (kg)

Example 1

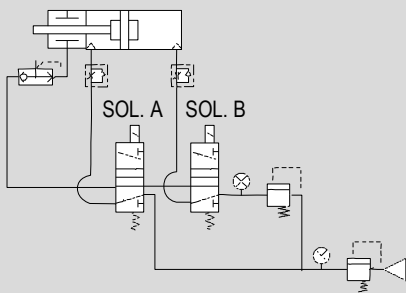

Example 2

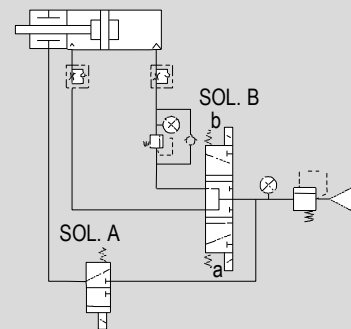

SOL. A	SOL. B	CYLINDER
ON	OFF	extended
OFF	OFF	stop
ON	OFF	extended
OFF	ON	retract
OFF	OFF	stop
OFF	ON	retract

SOL. A	SOL. B		CYLINDER
	a	b	
ON	OFF	ON	extended
OFF	OFF	OFF	stop
ON	OFF	ON	extended
ON	ON	OFF	retract
OFF	OFF	OFF	stop
ON	ON	OFF	retract

Vertical application

Type: **ABK**

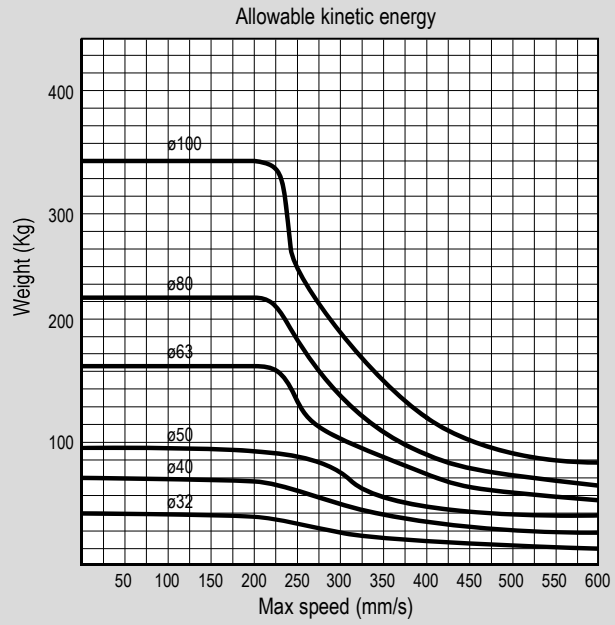
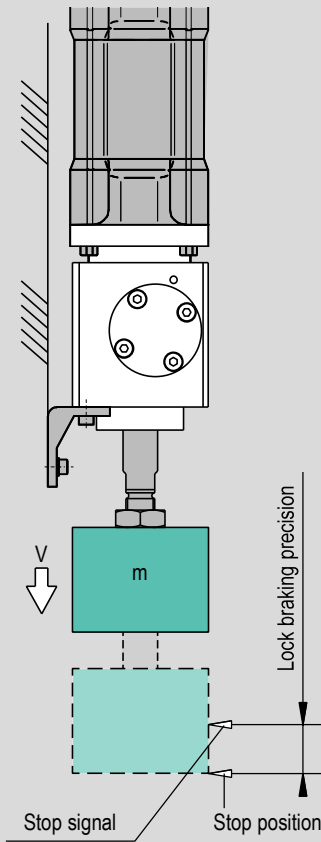

$$Ek = \frac{1}{2}mv^2$$

Ek: Kinetic energy (J)
 v: Speed (m/s)
 m: Weight (kg)

ROD ACCESSORIES

for Cylinders

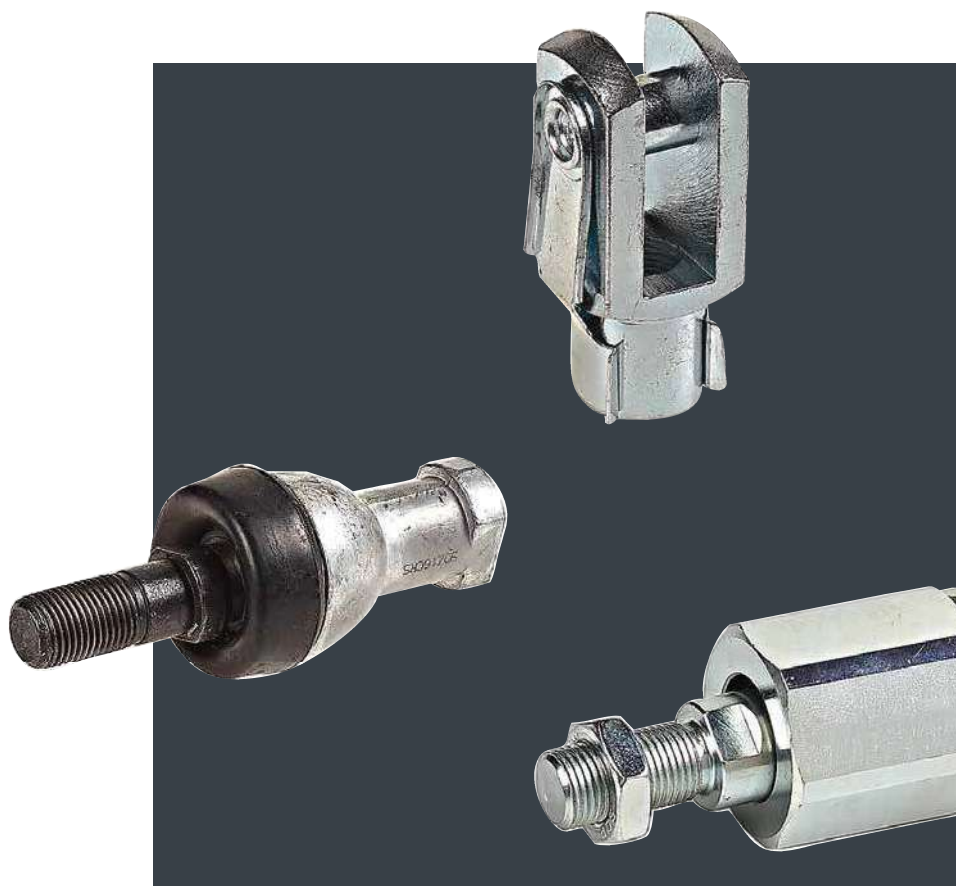

Find out our
key products



Solution for most applications



Easy and intuitive choice



Excellent value for money



Wide availability



Fast delivery



Features and certifications

Rod accessories for cylinders. Wide range of accessories for the cylinder piston rod to allow the choice of the most appropriate mounting. All rod accessories are supplied in compliance with Reach and RoHS directives.



Clevis ISO

from page 1.85.10



Series of female clevis conforming to ISO 8140 standard for mounting onto the male piston rod of the cylinder.

Clevis UNI e DIN

from page 1.86.1



Series of female clevis conforming to UNI 1676 and DIN 71752 standard for mounting onto the male piston rod of the cylinder.

Clevis CNOMO

from page 1.87.1



Series of female and male clevis conforming to CNOMO standard for mounting onto the male piston rod of the cylinder.

Clevis with male thread

from page 1.88.1



Series of female clevis with male thread conforming to UNI 1676 and DIN 71752 standard.

Bearing heads

from page 1.90.1



Bearings. Self-lubricating bearing heads (DIN 648K) servicing-free and conforming to ISO 8139 standard. Available with female thread or with male thread.

Self-aligning articulated coupling

from page 1.90.10



Bearings. Self-aligning articulated coupling. Supplied with hexagonal nut. For mounting onto the male piston rod of the cylinder. Allow to compensate the angular and parallel misalignments. Suitable for applications with high tractions.

Axial articulated couplings

from page 1.90.20



Bearings. Axial articulated couplings for mounting onto the male piston rod of the cylinder. Allow to compensate the angular and parallel misalignments.

Angle articulated couplings

from page 1.90.30



Bearings. Angle articulated couplings for mounting onto the male piston rod of the cylinder. Allow to compensate the angular misalignments.

Self-aligning coupling

from page 1.90.40



Couplings. Self-aligning articulated coupling for mounting onto the male piston rod of the cylinder. Allow to compensate the angular and parallel misalignments.

Rod nipples

from page 1.90.60



Rod nipple. for mounting onto the female piston rod of the cylinder.

Rod nuts

from page 1.90.70



Rod nut conforming to UNI 5589 and DIN 936 standard. For mounting onto the male piston rod of the cylinder.

Matching

Item	Description	Matching with cylinders									See page
		ISO 6432 MS.. MSM.. MD.. MDM.. MDMA..	ISO 15552 AMA.. AMT.. BMA.. BMT..	ROUND RS.. RD.. RDM.. RDMA..	CNOMO CX.. CM..	ISO 21287 CIS.. CI..	UNITOP CS.. CD..	COMPACT DU.. DUN.. DUM.. DUNM..	SHORT STROKE BS.. BSM.. BD.. BDM..	COMPACT "L" CLS.. CLSM.. CLD.. CLDM..	
FF..ISO	Female ISO Clevis	●	●	-	-	● ⁽¹⁾	● ⁽¹⁾	-	● ⁽²⁾	● ⁽²⁾	1.85.10
FFP..ISO	Female ISO Clevis	●	●	-	-	● ⁽¹⁾	● ⁽¹⁾	-	● ⁽²⁾	● ⁽²⁾	1.85.10
FFN..ISO	Female ISO Clevis	●	●	-	-	● ⁽¹⁾	● ⁽¹⁾	-	● ⁽²⁾	● ⁽²⁾	1.85.11
FF..DIN	Female UNI and DIN Clevis	-	-	●	-	-	-	●	-	-	1.86.1
FFP..DIN	Female UNI and DIN Clevis	-	-	●	-	-	-	●	-	-	1.86.1
FFN..DIN	Female UNI and DIN Clevis	-	-	●	-	-	-	●	-	-	1.86.2
FF..CN	Female CNOMO Clevis	-	-	-	●	-	-	-	-	-	1.87.1
FFP..CN	Female CNOMO Clevis	-	-	-	●	-	-	-	-	-	1.87.1
FFN..CN	Female CNOMO Clevis	-	-	-	●	-	-	-	-	-	1.87.1
FM..CN	Male CNOMO Clevis	-	-	-	●	-	-	-	-	-	1.87.2
FEM..	Female Clevis with male thread	-	● ^{(3) (5)}	-	-	●	●	-	-	-	1.88.1
RF..SE	Bearings - Bearing heads with female thread	●	●	● ⁽⁴⁾	●	● ⁽¹⁾	● ⁽¹⁾	● ⁽⁴⁾	● ⁽²⁾	● ⁽²⁾	1.90.1
RM..SE	Bearings - Bearing heads with male thread	-	● ^{(3) (4)}	-	-	●	●	-	●	●	1.90.2
GB..	Bearings - Self-aligning articulated coupling	●	●	●	●	● ⁽¹⁾	● ⁽¹⁾	●	● ⁽²⁾	● ⁽²⁾	1.90.10
RBI	Bearings - Axial articulated coupling	●	●	-	●	● ⁽¹⁾	● ⁽¹⁾	●	● ⁽²⁾	● ⁽²⁾	1.90.20
RBL	Bearings - Angle articulated coupling	●	●	-	●	● ⁽¹⁾	● ⁽¹⁾	●	● ⁽²⁾	● ⁽²⁾	1.90.30
GC..	Coupling - Self-aligning articulated coupling	●	●	-	●	● ⁽¹⁾	● ⁽¹⁾	-	● ⁽²⁾	● ⁽²⁾	1.90.40
N..AQB	Rod nipples	-	-	-	-	●	●	-	●	●	1.90.60
D..	Rod nuts	●	●	● ⁽⁴⁾	●	● ⁽¹⁾	● ⁽¹⁾	● ⁽⁴⁾	● ⁽²⁾	● ⁽²⁾	1.90.70

Key

- allowed matching; - not allowed matching
- (1) compatible only with cylinders with male thread option (M)
- (2) compatible only by mounting rod nipple type N..AQB
- (3) directly compatible only with cylinders having female thread
- (4) with coarse pitch thread
- (5) in combination with bearing head mounted on rod

Main features

8 ÷ 100 **FF..ISO**
Bores Ø 8140 Type

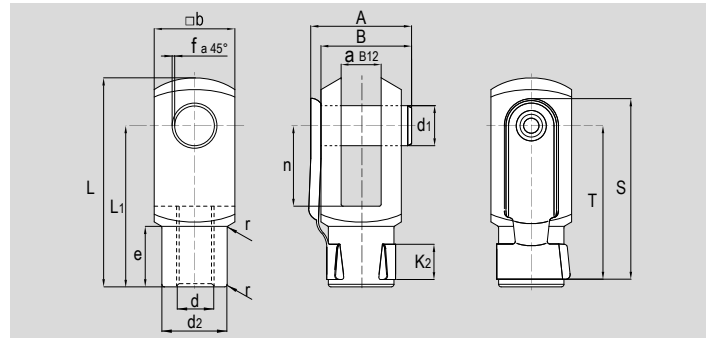

Options

Description	Suffix
Special versions on request	/S

Technical data

Type	Description	Materials
FF..ISO	Female clevis. Supplied complete with clips.	White zinc-plated steel

Dimensions

For cylinder Ø mm	Code	Item	d (thread)	a _{B12}	A	S	B	□b	d ₁	T	l ₂	d ₂	e	f (a 45°)	L	L ₁	n	r	Weight (g)
8-10	041001	FF04ISO/DIN	M4x0,7	4	11	19	9	8	4	15	5	8	6	0,5	21	16	8	0,5	7
12-16	041002	FF06ISO/DIN	M6x1	6	16	28	14	12	6	23	6	10	9	0,5	31	24	12	0,5	20
20	041003	FF08ISO/DIN	M8x1,25	8	22	37	19	16	8	31	8	14	12	0,5	42	32	16	0,5	48
25-32	041004	FF10ISO	M10x1,25	10	26	46	23	20	10	39	10	18	15	0,5	52	40	20	0,5	93
40	041005	FF12ISO	M12x1,25	12	32	55	28	24	12	47	12	20	18	0,5	62	48	24	0,5	154
50-63	041006	FF16ISO	M16x1,5	16	40	72	36	32	16	62	14	26	24	1	83	64	32	1	351
80-100	041007	FF20ISO	M20x1,5	20	48	88	44	40	20	72	16	34	30	1	105	80	40	1	680

Main features

25 ÷ 320 **FFP..ISO**
Bores Ø 8140 Type

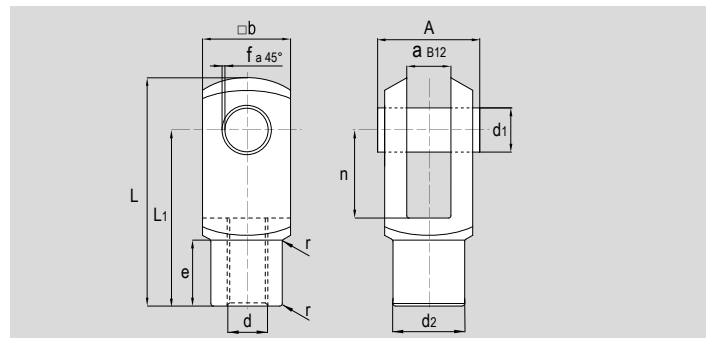

Options

Description	Suffix
Special versions on request	/S

Technical data

Type	Description	Materials
FFP..ISO	Female clevis. Supplied complete with pin and seeger.	White zinc-plated steel

Dimensions

For cylinder Ø mm	Code	Item	d (thread)	a _{B12}	A	□b	d ₁	d ₂	e	f (a 45°)	L	L ₁	n	r	Weight (g)
25-32	041051	FFP10ISO	M10x1,25	10	26	20	10	18	15	0,5	52	40	20	0,5	89
40	041040	FFP12ISO	M12x1,25	12	32	24	12	20	18	0,5	62	48	24	0,5	147
50-63	041013	FFP16ISO	M16x1,5	16	40	32	16	26	24	1	83	64	32	1	343
80-100	041017	FFP20ISO	M20x1,5	20	48	40	20	34	30	1	105	80	40	1	668
*	041008	FFP24ISO	M24x2	25	-	50	25	42	36	1	132	100	50	1	1330
125	041009	FFP27ISO	M27x2	30	-	55	30	48	38	1	148	110	54	1	1790
160-200	041010	FFP36ISO	M36x2	35	-	70	35	60	40	1	188	144	72	1	3550
250	041068	FFP42ISO	M42x2	40	104,3	85	40	70	63,5	1	232	168	84	5	6690
320	041069	FFP48ISO	M48x2	50	117,3	96	50	82	73	1	265	192	96	5	9954

* Per cylinders non a norme.

Rod accessories for cylinders

Clevis ISO



Main features

8 ÷ 320 **ISO** **FFN..ISO**
 Bores Ø 8140 Type

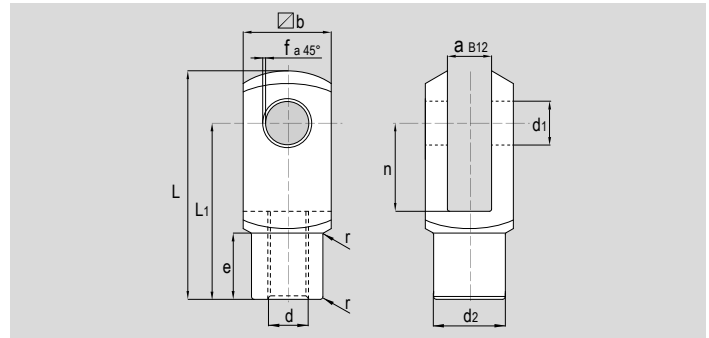

Options

Description	Suffix
Special versions on request	/S

Technical data

Type	Description	Materials
FFN..ISO	Female clevis. Body only.	White zinc-plated steel

Dimensions

For cylinder Ø mm	Code	Item	d (thread)	a _{B12}	∇b	d ₁	d ₂	e	f	L	L ₁	n	r	Weight (g)
8-10	041091	FFN04ISO/DIN	M4x0,7	4	8	4	8	6	0,5	21	16	8	0,5	5
12-16	041011	FFN06ISO/DIN	M6x1	6	12	6	10	9	0,5	31	24	12	0,5	15
20	041018	FFN08ISO/DIN	M8x1,25	8	16	8	14	12	0,5	42	32	16	0,5	37
25-32	041014	FFN10ISO	M10x1,25	10	20	10	18	15	0,5	52	40	20	0,5	74
40	041016	FFN12ISO	M12x1,25	12	24	12	20	18	0,5	62	48	24	0,5	121
50-63	041012	FFN16ISO	M16x1,5	16	32	16	26	24	1	83	64	32	1	282
80-100	041015	FFN20ISO	M20x1,5	20	40	20	34	30	1	105	80	40	1	550
*	041021	FFN24ISO	M24x2	25	50	25	42	36	1	132	100	50	1	1110
125	**	FFN27ISO	M27x2	30	55	30	48	38	1	148	110	54	1	1440
160-200	**	FFN36ISO	M36x2	35	70	35	60	40	1	188	144	72	1	2930
250	**	FFN42ISO	M42x2	40	85	40	70	63,5	1	232	168	84	5	5670
320	**	FFN48ISO	M48x2	50	96	50	82	73	1	265	192	96	5	8154

* For cylinders non conforming to standards; ** For code please contact the sales department

Main features

UNI	DIN	FF..DIN
1676	71752	Type

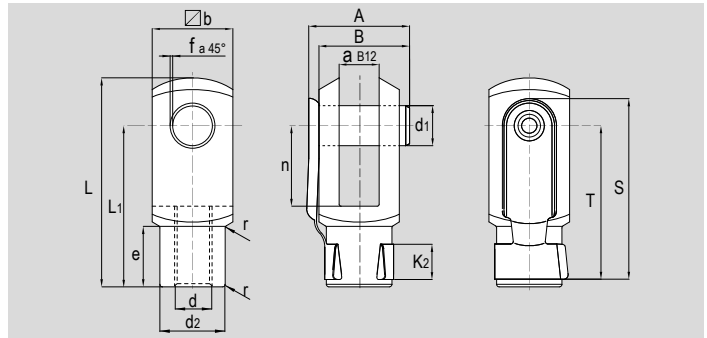

Options

Description	Suffix
Special versions on request	/S

Technical data

Type	Description	Materials
FF..DIN	Female clevis. Supplied complete with clips.	White zinc-plated steel

Dimensions

Code	Item	d (thread)	a _{B12}	A	B	∇b	d ₁	S	T	K ₂	d ₂	e	f (a 45°)	L	L ₁	n	r	Weight (g)
041001	FF04ISO/DIN	M4x0,7	4	11	9	8	4	19	15	5	8	6	0,5	21	16	8	0,5	7
041022	FF05DIN	M5x0,8	5	13,5	12	10	5	23	19	6	9	7,5	0,5	26	20	10	0,5	12
041002	FF06ISO/DIN	M6x1	6	16	14	12	6	28	23	6	10	9	0,5	31	24	12	0,5	20
041003	FF08ISO/DIN	M8x1,25	8	22	19	16	8	37	31	8	14	12	0,5	42	32	16	0,5	48
041025	FF10DIN	M10x1,5	10	26	23	20	10	46	39	10	18	15	0,5	52	40	20	0,5	93
041026	FF12DIN	M12x1,75	12	32	28	24	12	55	47	12	20	18	0,5	62	48	24	0,5	154
041027	FF14DIN	M14x2	14	-	-	27	14	-	-	-	24	22,5	1	72	56	28	1	224
041028	FF16DIN	M16x2	16	40	36	32	16	72	62	14	26	24	1	83	64	32	1	351
041030	FF20DIN	M20x2,5	20	48	44	40	20	88	72	16	34	30	1	105	80	40	1	680

Main features

UNI	DIN	FFP..DIN
1676	71752	Type

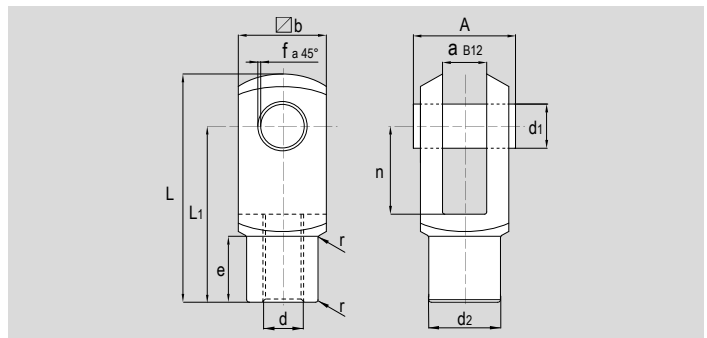

Options

Description	Suffix
Special versions on request	/S

Technical data

Type	Description	Materials
FFP..DIN	Female clevis. Supplied complete with pin and seeger.	White zinc-plated steel

Dimensions

Code	Item	d (thread)	a _{B12}	A	∇b	d ₁	d ₂	e	f (a 45°)	L	L ₁	n	r	Weight (g)
041096	FFP10DIN	M10x1,5	10	26	20	10	18	15	0,5	52	40	20	0,5	89
041217	FFP12DIN	M12x1,75	12	32	24	12	20	18	0,5	62	48	24	0,5	147
041213	FFP16DIN	M16x2	16	40	32	16	26	24	1	83	64	32	1	343
*	FFP20DIN	M20x2,5	20	48	40	20	34	30	1	105	80	40	1	668
041067	FFP24DIN	M24x3	25	-	50	25	42	36	1	132	100	50	1	1330

* For code please contact the sales department

Rod accessories for cylinders

Clevis UNI and DIN



Main features

UNI	DIN	FFN..DIN
1676	71752	Type

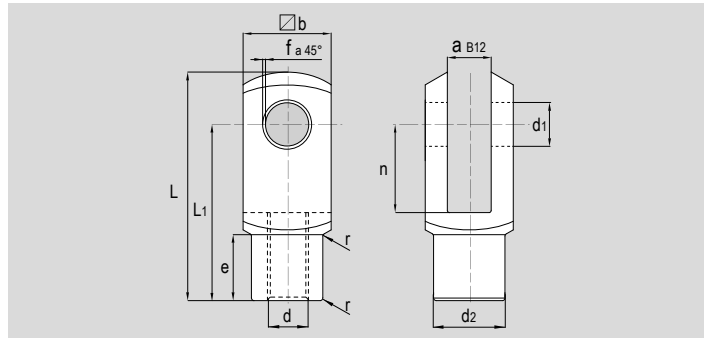

Options

Description	Suffix
Special versions on request	/S

Technical data

Type	Description	Materials
FFN..DIN	Female clevis. Body only.	White zinc-plated steel

Dimensions

Code	Item	d (thread)	a _{B12}	∅b	d ₁	d ₂	e	f	L	L ₁	n	r	Weight (g)
041091	FFN04ISO/DIN	M4x0,7	4	8	4	8	6	0,5	21	16	8	0,5	5
041011	FFN06ISO/DIN	M6x1	6	12	6	10	9	0,5	31	24	12	0,5	15
041018	FFN08ISO/DIN	M8x1,25	8	16	8	14	12	0,5	42	32	16	0,5	37
041020	FFN10DIN	M10x1,5	10	20	10	18	15	0,5	52	40	20	0,5	74
041203	FFN12DIN	M12x1,75	12	24	12	20	18	0,5	62	48	24	0,5	121
041202	FFN16DIN	M16x2	16	32	16	26	24	1	83	64	32	1	282
041205	FFN20DIN	M20x2,5	20	40	20	34	30	1	105	80	40	1	550
041067	FFN24DIN	M24x3	25	50	25	42	36	1	132	100	50	1	1110

Main features

25 ÷ 125 **CNOMO** FF..CN

Bores Ø Type

Options

Description	Suffix
Special versions on request	/S

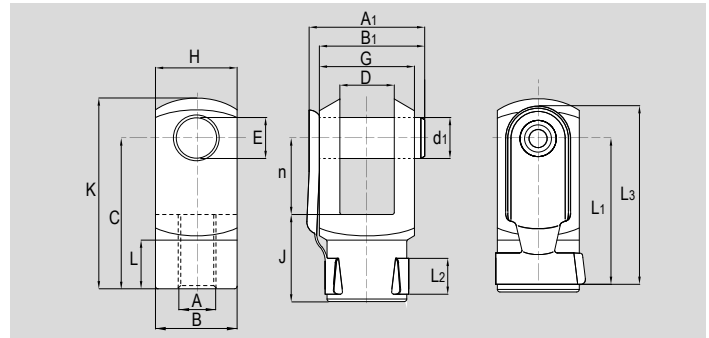

Technical data

Type	Description	Materials
FF..CN	Female clevis. Supplied complete with clips.	White zinc-plated steel

Dimensions

For cylinder Ø mm	Code	Item	A (thread)	A ₁	B	B ₁	C	D h ₁₁	d ₁ h ₁₁	E h ₈	G	H	L ₁	J	L ₂	K	L ₃	L	n	Weight (g)
25-32	041081	FF10CN	M10x1,5	28	18	25	36	11	8	8	22	22	36	20	10	45	41	14	16	94
40-50	041082	FF16CN	M16x1,5	44	26	40	51	18	12	12	36	26	50	26	12	64	60	17	25	253
63-80	041084	FF20CN	M20x1,5	53	34	49	63	22	16	16	45	34	63	30	15	80	74	18,5	33	530
100-125	041086	FF27CN	M27x2	73	42	69	85	30	20	20	63	42	81	45	19	105	98	30	40	1110

Main features

25 ÷ 200 **CNOMO** FFP..CN

Bores Ø Type

Options

Description	Suffix
Special versions on request	/S

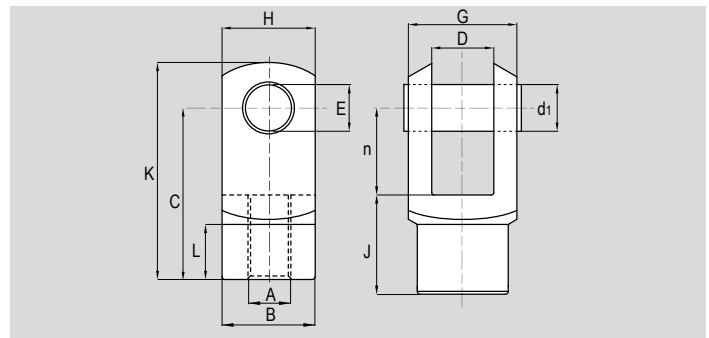

Technical data

Type	Description	Materials
FFP..CN	Female clevis. Supplied complete with pin and seeger	White zinc-plated steel
FFN..CN*	Female clevis. Body only.	

Dimensions

For cylinder Ø mm	Code	Item	A (thread)	B	C	D h ₁₁	d ₁ h ₁₁	E h ₈	G	H	J	K	L	n	Weight (g)
25-32	041106	FFP10CN	M10x1,5	18	36	11	8	8	22	22	20	45	14	16	94
40-50	041105	FFP16CN	M16x1,5	26	51	18	12	12	36	26	26	64	17	25	253
63-80	041097	FFP20CN	M20x1,5	34	63	22	16	16	45	34	30	80	18,5	33	530
100-125	041087	FFP27CN	M27x2	42	85	30	20	20	63	42	45	105	30	40	1110
160-200	041088	FFP36CN	M36x2	50	115	40	25	25	80	50	75	140	45	-	2160

* For type FFN..CN clevis codes, please contact the sales department;

Rod accessories for cylinders

Clevis CNOMO



Main features

25 ÷ 200 **CNOMO** FM..CN

Bores Ø Type

Options

Description	Suffix
Special versions on request	/S

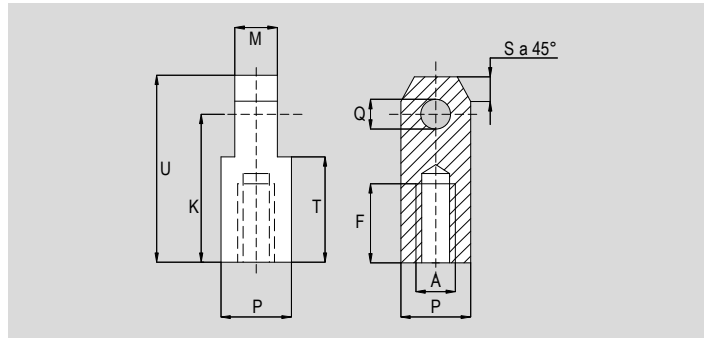

Technical data

Type	Description	Materials
FM..CN	Male clevis. Supplied complete with pin and seeger	White zinc-plated steel
FMN..CN*	Male clevis. Body only.	

Dimensions

For cylinder Ø mm	Code	Item	A (thread)	F	M	P	Q h8	S	T	U	K	Weight (g)
25-32	041041	FM10CN	M10x1,5	20	11	22	8	6	25	45	36	-
40-50	041042	FM16CN	M16x1,5	30	18	32	12	10	34	64	51	-
63-80	041044	FM20CN	M20x1,5	36	22	36	16	12	41	80	63	-
100-125	041046	FM27CN	M27x2	50	30	45	20	17,5	58	105	85	-
160-200	041048	FM36CN	M36x2	70	40	63	25	20	81	140	115	-

* For type FMN..CN clevis codes, please contact the sales department;

Rod accessories for cylinders

Clevis with male thread



Main features



FEM

1676

71752

Type

Options

Description	Suffix
Special versions on request	/S

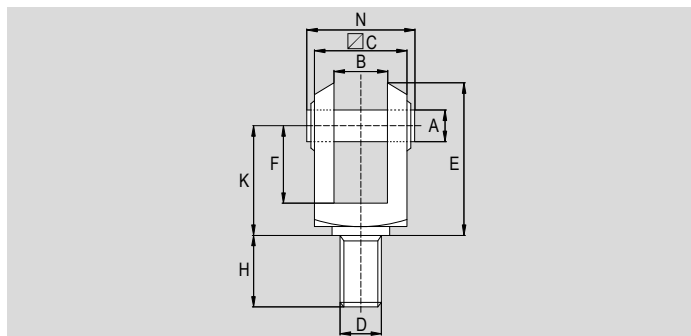

Technical data

Type	Description	Materials
FEM..	Female clevis with male thread. Supplied complete with pin and seeger	White zinc-plated steel

Dimensions

Code	Item	D (thread)	ØA	B	∇C	E	K	F	H	N	Weight (g)
041061	FEM10	M10x1,25	10	10	20	39	27	20	22	27	-
041062	FEM12	M12x1,25	12	12	24	46	32	24	24	31	-
041063	FEM16	M16x1,5	16	16	32	61	42	32	32	39	-
041064	FEM20	M20x1,5	20	20	40	77	52	40	40	49	-
041065	FEM27	M27x2	25	25	50	98	66	50	43	59	-
041066	FEM33	M33x2	28	28	55	110	74	56	56	64	-

Rod accessories for cylinders

Bearings - Bearing heads



Main features

8 ÷ 320



RF..SE

Bores Ø

8139

Type

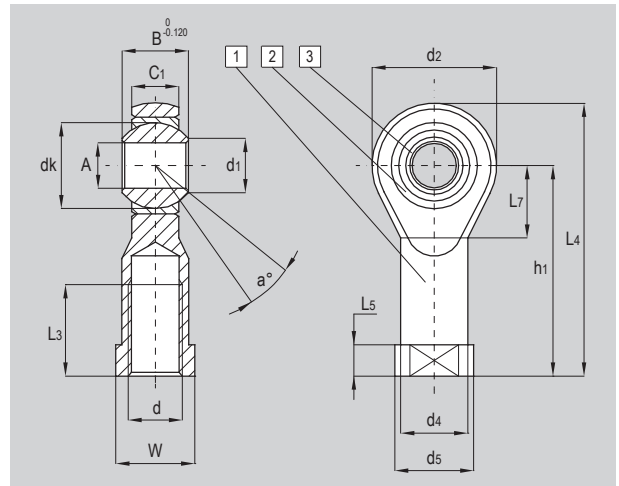

Options

Description	Suffix
Left thread	S
Special versions on request	/S

Technical data

Type	Description	Temperature range
RF..SE	Bearings. Bearing head (DIN 648K) self lubricating and servicing free, with female thread.	-30°C ÷ +150°C

Standard materials

Position	Description	Material
1	Body	Zinc-plated / nichel-plated steel
2	Sphere	Hardened ground polished steel
3	External ring	Self lubricated brass / PTFE

Dimensions

For cylinders ISO Ø mm	Code	Item	d _{h6} (thread)	A _{h7}	B	C ₁	d ₁	d ₂	d ₄	d ₅	dk	h ₁	L ₃	L ₄	L ₅	L ₇	W	a°	Static load (daN)	Weight (g)
8-10	041551	RF5SE	M4	5	8	6	7,7	18	9	11	11,11	27	10	36	4	10	9	13	600	20
12-16	041552	RF6SE	M6	6	9	6,75	8,9	20	10	13	12,70	30	12	40	5	11	11	13	700	25
20	041553	RF8SE	M8	8	12	9	10,4	24	12,5	16	15,88	36	16	48	5	13	14	14	1200	47
25-32	041554	RF10SE	M10x1,25	10	14	10,5	12,9	28	15	19	19,05	43	20	57	6,5	15	17	13	1400	88
40	041555	RF12SE	M12x1,25	12	16	12	15,4	32	17,5	22	22,23	50	22	66	6,5	17	19	13	1900	140
50-63	041557	RF16SE	M16x1,5	16	21	15	19,3	42	22	27	28,58	64	28	85	8	23	22	15	4800	250
80-100	041559	RF20SE	M20x1,5	20	25	18	24,3	50	27,5	34	34,93	77	33	102	10	27	30	14	5200	430
125	041562	RF30SE	M27x2	30	37	25	34,8	70	40	50	50,80	110	51	145	15	36	41	17	10800	1200
160-200	041563	RF35SE	M36x2	35	43	28	37,7	80	46	58	57,15	125	56	165	17	41	50	19	12400	1959
250	041571	RF40SE	M42x2	40	49	33	45,2	91	53	65	66,67	142	60	187,5	19	45	55	17	-	-
320	041572	RF50SE	M48x2	50	60	45	56,6	117	65	75	82,50	160	65	218,5	23	58	65	12	-	-

Note: available also with coarse pitch thread and other sizes. For availability and codes, please contact the sales department.

Rod accessories for cylinders

Bearings - Bearing heads



Main features



RM..SE

8139

Type

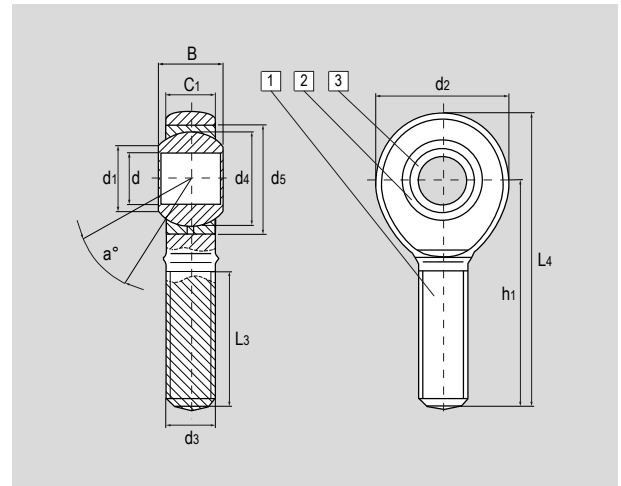

Options

Description	Suffix
Left thread	S
Special versions on request	/S

Technical data

Type	Description	Temperature range
RM..SE	Bearings. Bearing head (DIN 648K) self lubricating and servicing free, with male thread.	-30°C ÷ +150°C

Standard materials

Position	Description	Material
1	Body	Zinc-plated / nichel-plated steel
2	Sphere	Hardened ground polished steel
3	External ring	Self lubricated brass / PTFE

Dimensions

d ₃ (thread)	Code	Item	d	d ₁	d ₂	d ₄	B	C ₁	d ₅	h ₁	L ₃	L ₄	a°	Dynamic load (KN)	Static load (KN)	Weight (g)
M4x0,7	041500	RM4SE	5	7,7	18	11,11	8	6	13	33	19	42	13	3,2	5,2	10
M5x0,8	041501	RM5SE	5	7,7	18	11,11	8	6	13	33	19	42	13	3,2	5,2	10
M6x1	041502	RM6SE	6	8,9	20	12,70	9	6,75	16	36	21	46	13	4,2	6,7	20
M8x1,25	041503	RM8SE	8	10,4	24	15,88	12	9	19	42	25	54	14	7,0	9,9	30
M10x1,25	041504	RM10SE	10	12,9	28	19,05	14	10,5	22	48	28	63	13	9,6	12,4	50
M12x1,25	041505	RM12SE	12	15,4	32	22,23	16	12	26	54	32	71	13	13,0	14,8	85
M16x1,5	041507	RM16SE	16	19,3	42	28,58	21	15	32	66	37	87	15	21,3	34,3	180
M20x1,5	041509	RM20SE	20	24,3	50	34,93	25	18	40	78	45	103	14	30,9	49,8	340
M27x2	041512	RM30SE	30	34,8	70	50,8	37	25	-	110	66	145	17	71,9	96,7	1070
M36x2	041513	RM35SE	35	37,7	80	57,15	43	28	-	140	85	180,5	19	-	-	1640
M42x2	041515	RM40SE	40	45,2	91	66,67	49	33	-	150	90	195,5	17	-	-	2300
M48x2	041516	RM50SE	50	56,6	117	82,5	60	45	-	185	105	243,5	12	-	-	4800

Note: available also with coarse pitch thread and other sizes. For availability and codes, please contact the sales department.

Rod accessories for cylinders

Bearings - Self-aligning articulated coupling



Main features

8 ÷ 320

GB

Bores Ø

Type



Options

Description	Suffix
Special versions on request	/S

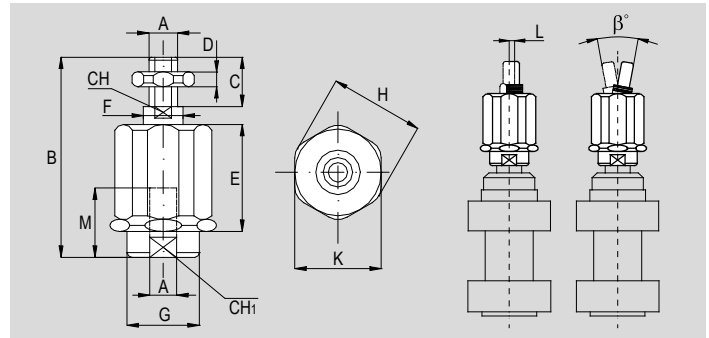

Technical data

Type	Description	Materials
GB..	Bearings. Self-aligning articulated coupling. Supplied with hexagonal nut. For mounting onto the male piston rod of the cylinder. Allow to compensate the angular and parallel misalignments. Suitable for applications with high tractions.	Zinc-plated steel

Dimensions

For cylinders ISO Ø mm	Code	Item	A (thread)	B	C	D	E	ØF	ØG	ØH	K	L	M	β°	CH	CH ₁	Max thrust and traction load (N)	Weight (g)
8-10	041701	GB008	M4x0,7	33	8	2,2	15,5	6	8,5	14,5	12	1	10	10	3,2	12	750	20
*	041700	GB005	M5x0,8	38,5	13,5	2,5	17,5	6	8,5	14,5	13	1	10	10	5	7	1200	20
12-16	041702	GB010	M6x1	39	12	3,2	17,5	6	8,5	14,5	13	1	10	10	5	7	1200	30
20	041703	GB020	M8x1,25	58	16	4	24,5	8	12,5	19	17	2	20	10	7	10	2500	60
25-32	041704	GB040	M10x1,25	73	20	5	34	14	21	32	30	2	20	10	12	19	5000	220
*	041705	GB050	M10x1,5	73	20	5	34	14	21	32	30	2	20	10	12	19	5000	220
40	041706	GB060	M12x1,25	77	24	6	34	14	21	32	30	2	20	10	12	19	5000	230
*	041707	GB090	M12x1,75	77	24	6	34	14	21	32	30	2	20	10	12	19	5000	230
50-63	041708	GB100	M16x1,5	108	32	8	54	22	33,5	45	41	2	32	10	19	30	10000	660
80-100	041709	GB120	M20x1,5	122	40	9	54	22	33,5	45	41	2	40	10	19	30	10000	700
125	041711	GB130	M27x2	147	54	13,5	71	-	59	60	55	-	40	-	24	32	-	1600
160-200	041712	GB160-200	M36x2	241	72	14	125	-	56	80	75	-	40	-	36	50	-	5100
250	041713	GB250	M42x2	271	82	16	148	-	64	98	85	-	40	-	36	60	-	9200
320	041714	GB320	M48x2	271	82	18	-	-	-	-	90	-	40	-	42	60	-	-

* For cylinders not conforming to ISO standards

Rod accessories for cylinders

Bearings - Axial articulated couplings



Main features

12 ÷ 100

RBI

Bores Ø

Type



Options

Description	Suffix
Special versions on request	/S

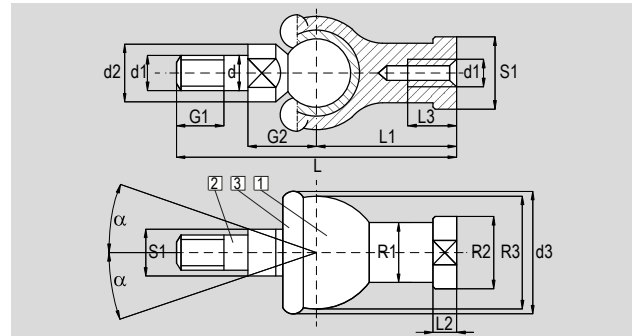

Technical data

Type	Description	Temperature range
RBI..	Bearings. Axial articulated couplings for mounting onto the male piston rod of the cylinder. Allow to compensate the angular and parallel misalignments.	-20°C ÷ +80°C

Standard materials

Position	Description	Material
1	Body	Special zinc alloy
2	Pin	Zinc-plated steel
3	Seal	Neoprene (pre-lubricated spherical coupling)

Dimensions

For cylinders ISO Ø mm	Code	Item	d	d ₁ (thread)	d ₂	d ₃	G ₁	G ₂	L	L ₁	L ₂	L ₃	R ₁	R ₂	R ₃	S ₁	S ₂	α	Dynamic load (KN)	Static load (KN)	Weight (g)
*	041601	RBI5	5	M5x0,8	9	20	8	11	46	24	4	12	9	11	17	7	9	15	1,7	5,7	25
12-16	041602	RBI6	6	M6x1	10	20	11	12,2	55,2	28	5	15	10	13	20	8	11	15	2,2	7,5	40
20	041603	RBI8	8	M8x1,25	12	24	12	16	65	32	5	16	12,5	16	24	10	14	15	3,3	11,0	75
25-32	041604	RBI10	10	M10x1,25	14	30	15	19,5	74,5	35	6,5	18	15	19	28	11	17	15	4,8	16,0	121
*	041611	RBI10x1,5	10	M10x1,5	14	30	15	19,5	74,5	35	6,5	18	15	19	28	11	17	15	4,8	16,0	121
40	041605	RBI12	12	M12x1,25	17	32	17	21	84	40	6,5	20	17,5	22	32	15	19	15	6,6	22,0	187
*	041606	RBI14	14	M14x1,5	19	38	22	23,5	104,5	45	8	25	20	25	36	17	22	11	8,7	29,0	277
50-63	041607	RBI16	16	M16x1,5	22	44	23	25,5	112	50	8	27	22	27	40	19	22	11	10,0	33,0	361
*	041608	RBI18	18	M18x1,5	23	45	25	31	130,5	58	10	32	25	31	45	20	27	11	11,0	37,0	539
80-100	041609	RBI20	20	M20x1,5	27	50	25	29	133	63	10	38	27,5	34	45	24	30	7,5	11,0	37,0	575
*	041610	RBI22	22	M22x1,5	27	52	26	33	145	70	12	43	30	37	50	24	32	7,5	14,0	46,0	757

* For cylinders not conforming to ISO standards

Rod accessories for cylinders

Bearings - Angle articulated couplings



Main features

12 ÷ 100

RBL

Bores Ø

Type

Options

Description	Suffix
Special versions on request	/S

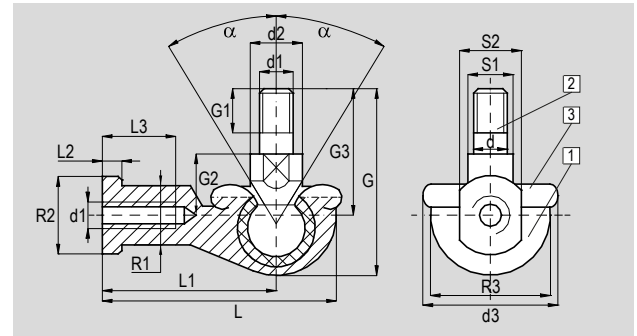

Technical data

Type	Description	Temperature range
RBL..	Bearings. Angle articulated couplings for mounting onto the male piston rod of the cylinder. Allow to compensate the angular misalignments.	-20°C ÷ +80°C

Standard materials

Position	Description	Material
1	Body	Special zinc alloy
2	Pin	Zinc-plated steel
3	Seal	Neoprene (pre-lubricated spherical coupling)

Dimensions

For cylinders ISO Ø mm	Code	Item	d	d ₁ (thread)	d ₂ min	d ₃ max	G max	G ₁ min	G ₂	G ₃ max	L max	L ₁	L ₂ max	L ₃ min	R ₁ max	R ₂ max	R ₃ max	S ₁	S ₂	α	Dynamic load (KN)	Static load (KN)	Weight (g)
*	041651	RBL5	5	M5x0,8	9	20	30	8	10	21	36	27	4	14	9	12	18	7	10	9,2	25	2,7	26
12-16	041652	RBL6	6	M6x1	10	20	36	11	11	26	40,5	30	5	14	10	13	20	8	10	12	25	3,6	39
20	041653	RBL8	8	M8x1,25	12	24	43,5	12	14	31	49	36	5	17	12,5	16	25	10	13	19	25	5,7	68
25-32	041654	RBL10	10	M10x1,25	14	30	51,5	15	17	37	58	43	6,5	24	15	19	29	11	16	27	25	8,2	112
40	041655	RBL12	12	M12x1,25	19	32	57,5	17	19	42	66	50	6,5	25	17,5	22	31	16	18	37	25	11	164
*	041656	RBL14	14	M14x1,5	19	38	73,5	22	21,5	56	75	57	8	26	20	25	35	16	21	48	25	14	254
50-63	041657	RBL16	16	M16x1,5	22	44	79,5	23	23,5	60	84	64	8	32	22	27	39	18	24	53	20	16	336
*	041658	RBL18	18	M18x1,5	25	45	90	25	26,5	68	93	71	10	34	25	31	44	21	27	61	20	18	464
80-100	041659	RBL20	20	M20x1,5	29	50	90	25	27	68	99	77	10	35	27,5	34	44	24	30	61	20	18	538
*	041660	RBL22	22	M22x1,5	29	52	95	26	28	70	109	84	12	41	30	37	50	24	30	75	16	22	713

* For cylinders not conforming to ISO standards

Rod accessories for cylinders

Couplings - Self-aligning coupling



Main features

25 ÷ 200

GC

Bores Ø

Type

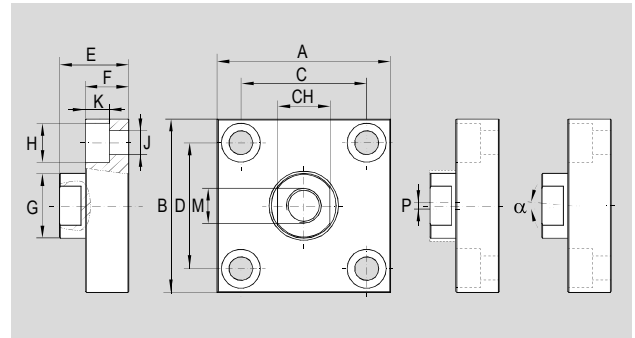

Options

Description	Suffix
Special versions on request	/S

Technical data

Type	Description	Materials
GC..	Couplings. Self-aligning articulated coupling for mounting onto the male piston rod of the cylinder. Allow to compensate the angular and parallel misalignments.	Zinc-plated steel

Dimensions

M (thread)	Code	Item	A	B	C	D	CH	E	F	ØG	ØH	ØJ	K	P	α	Weight (g)
M10x1,25	041722	GCM10x1,25	60	37	36 ±0,15	23 ±0,15	17	24	15	20	11	6,6	7	2	0,4±0,8	30
M12x1,25	041723	GCM12x1,25	60	56	42 ±0,2	38 ±0,2	19	30	20	25	15	9	9	2	0,4±0,8	40
M16x1,5	041724	GCM16x1,5	80	80	58 ±0,2	58 ±0,2	24	32	20	30	18	11	11	2	0,4±0,8	90
M20x1,5	041725	GCM20x1,5	90	90	65 ±0,2	65 ±0,2	36	35	20	40	20	14	13	2	0,4±0,8	110
M27x2	041726	GCM27x2	90	90	65 ±0,2	65 ±0,2	36	35	20	40	20	14	13	2	0,4±0,8	110
M36x2	041727	GCM36x2	125	125	90 ±0,2	90 ±0,2	50	55	30	60	26	18	17	3	0,4±0,95	340

Rod accessories for cylinders

Rod nipples



Main features

12 ÷ 100

Bores Ø

N..AQB

Type

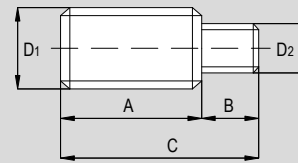

Technical data

Type	Description	Materials
N..AQB	Rod nipple. for mounting onto the female piston rod of the cylinder. Allow mounting female threaded accessories on standard short stroke cylinders.	Zinc-plated steel

Dimensions

For cylinder Ø mm	Code	Item	D ₁ (male thread 1)	D ₂ (male thread 2)	A	B	C	Weight (g)
12	040079	N6-3AQB	M6x1	M3x0,5	16	6,5	22,5	-
16	040080	N6-4AQB	M6x1	M4x0,7	15	8	23	-
20-25	040081	N8-5AQB	M8x1,25	M5x0,8	20	10	30	-
32-40	040082	N10-6AQB	M10x1,25	M6x1	22	12	34	-
50-63	040083	N12-8AQB	M12x1,25	M8x1,25	24	14	38	-
50-63	040084	N16-8AQB	M16x1,5	M8x1,25	32	14	46	-
80	040085	N16-10AQB	M16x1,5	M10x1,5	32	15	47	-
100	040086	N20-12AQB	M20x1,5	M12x1,75	40	20	60	-

Rod accessories for cylinders

Rod nuts



Main features

8 ÷ 320

Bores Ø



5589

D

Type



936

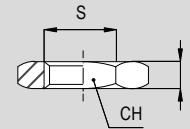

Technical data

Type	Description	Materials
D..	Rod nut conforming to UNI 5589 and DIN 936 standard. For mounting onto the male piston rod of the cylinder.	Zinc-plated steel

Dimensions

Code	Item	S (thread)	L	CH	Weight (g)
881397	D4x0,7	M4x0,7	2,8	7	0,6
041450	D6x1	M6x1	4	10	2,0
041451	D8x1,25	M8x1,25	5	13	4,0
041452	D10x1,25	M10x1,25	6	17	8,5
041453	D10x1,5	M10x1,5	6	17	9,0
041454	D12x1,25	M12x1,25	7	19	11,5
041455	D16x1,5	M16x1,5	8	24	20,0
041456	D20x1,5	M20x1,5	9	30	34,0
041458	D27x2	M27x2	12	41	87,0
041459	D36x2	M36x2	14	55	184,0
041449	D42x2	M42x2	16	65	295,0
041477	D48x2	M48x2	18	75	444,0

Note: available also with coarse pitch thread and other sizes. For availability and codes, please contact the sales department.

MOUNTING ACCESSORIES

for Cylinders



Find out our
key products



Solution for most applications



Easy and intuitive choice



Excellent value for money



Wide availability



Fast delivery



Features and certifications

Series of mounting accessories for cylinders. For front, rear or center mounting, or with others accessories (e.g.: hinges), to allow the choice of the most appropriate mounting. All mounting accessories are supplied in compliance with Reach and RoHS directives.



Steel mountings for cylinders ISO 6432

from page 1.95.1



Mountings for cylinders ISO 6432. Rear clevises ISO MP3, flanges ISO MS3 and high feet ISO MF8 in steel, white zinc plating treatment.

Steel mountings for round cylinders

from page 1.96.1



Mountings for round cylinders from bore 32 to bore 63. Rear clevis, foot-hinges, foot-flanges, pins and head nuts in steel, white zinc plating treatment.

Aluminium mountings for cylinders ISO 15552

from page 1.97.1



Mountings for cylinders ISO 15552. Rear female clevises ISO MP2, rear eyes ISO MP4, Narrow rear clevises ISO AB6 and narrow rear eyes ISO MP6 with DIN 648K bearing, front clevises ISO MP7, flanges ISO-VDMA MF1/MF2, rear 90° hinges ISO AB7 CETOP RP107P and ISO 6431, in die-cast aluminium, sifting treatment.

Steel mountings for cylinders ISO 15552

from page 1.98.1



Mountings for cylinders ISO 15552. Rear female clevises ISO MP2, rear eyes ISO MP4, narrow rear female clevises ISO AB6 and narrow rear eye ISO MP6 with DIN 648K bearings, flanges ISO-VDMA MF1/MF2, rear 90° hinges ISO AB7 CETOP RP107P and ISO CS7 with DIN 648K bearings, low feet ISO MS1, pins ISO AA4 and ISO AA6, center trunnions ISO MT4 and ISO MT5/MT6, in AVP steel, in Fe 37 or in A105 steel, black cataphoresis or white zinc plating treatment.

Aluminium mountings for cylinders CNOMO

from page 1.99.1



Mountings for cylinders CNOMO. Rear female clevises, rear standard hinges, rear 90° hinges and high feet in die cast aluminium, sifting treatment.

Steel mountings for cylinders CNOMO

from page 1.99.50



Mountings for cylinders CNOMO. Flanges, low feet, pins and center trunnion in AVP steel, in Fe 37 or in A105 steel, white zinc plating treatment.

Aluminium mountings for compact cylinders ISO 21287

from page 1.100.1



Mountings for compact cylinders ISO 21287. Rear female clevis ISO MP2, rear male eye ISO MP4, narrow rear female clevises ISO AB6 and narrow rear male eye ISO MP6 with DIN 648K bearings, front clevises ISO MP7, flanges ISO-VDMA MF1/MF2, rear 90° hinges ISO AB7 CETOP RP107P and ISO 6431 in die cast aluminium, sifting treatment.

Steel mountings for compact cylinders ISO 21287

from page 1.100.50



Mountings for compact cylinders ISO 21287. Rear female clevis ISO MP2, rear male eye ISO MP4, narrow rear female clevises ISO AB6 and narrow rear male eye ISO MP6 with DIN 648K bearings, flanges ISO-VDMA MF1/MF2, rear 90° hinges ISO AB7 CETOP RP107P and ISO CS7 with DIN 648K bearings, low feet ISO MS1, pins ISO AA4 and ISO AA6, center trunnion ISO MT5/MT6, in AVP steel, in Fe 37 or in A105 steel, black cataphoresis or white zinc plating treatment.

Aluminium mountings for compact cylinders UNITOP

from page 1.100.100



Mountings for compact cylinders UNITOP. Rear female clevises ISO MP2, rear eyes ISO MP4, flanges and rear 90° hinges ISO AB7 CETOP RP107P in die cast aluminium, sifting treatment.

Steel mountings for compact cylinders UNITOP

from page 1.100.150



Mountings for compact cylinders UNITOP. Rear female clevises ISO MP2, rear eyes ISO MP4, low feet, flanges and rear 90° hinges ISO AB7 CETOP RP107P in A105 steel A105, Fe 37, black cathodolysis treatment or white zinc plating treatment.

Aluminium mountings for short stroke cylinders

from page 1.100.200



Mountings for short stroke cylinders. Integrated rear male eye and feet in aluminium.

Aluminium mountings for rodless cylinders

from page 1.100.250



Mountings for rodless cylinders. Feet, mid support, end supports and flexible coupling in aluminium.

Mountings for hand grips

from page 1.100.350



Mountings for hand grips. Male and female in aluminium, plates in Stainless Steel.

Connecting bracket for slide units

from page 1.100.400



Connecting bracket for rods of slide units for cylinders ISO 15552.

Mounting screws, nuts and growers in steel for cylinders

from page 1.101.1



Mounting elements for cylinders. Screws conforming to UNI5931 standards, nuts conforming to UNI5589 and DIN 936 standards, growers conforming to DIN 127B standards, in steel.

Mounting accessories for cylinders

Mountings in steel for cylinders ISO 6432



Main features

8 ÷ 25

Bores Ø



MP3

CF

Type

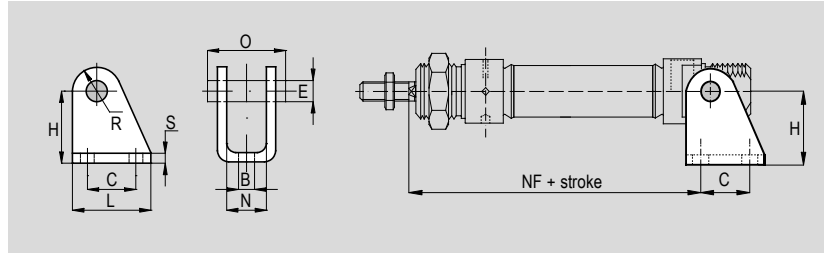

Technical data

Type	Description	Material	Treatment
CF..+P	Mounting for cylinders in steel. Rear clevis. Supplied with pin and two seeger.	Zinc plated steel	White zinc plating

Dimensions

For cylinder Ø mm	Code	Item	B	E	C	H	L	N	O	R	S	NF	Weight (g)
8	040048	CF08-10+P	4,5	4	12,5	24	20	8,1	17	5	2,5	62,5	42
10													
12	040049	CF12-16+P	5,5	6	15	27	25	12,1	23	7	3	73	75
16												80	
20	040050	CF20-25+P	6,6	8	20	30	32	16,1	29,5	10	4	91	78
25												100	

Main features

8 ÷ 25

Bores Ø



MS3

P

Type

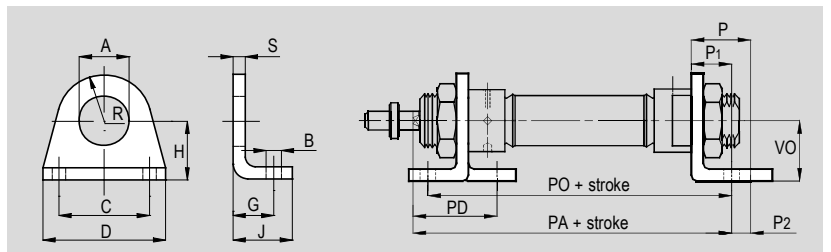

Technical data

Type	Description	Material	Treatment
P..	Mounting for cylinders in steel. High foot. For rear or front mounting (head nut required. One head nut supplied with cylinders as standard). Supplied individually.	Zinc plated steel	White zinc plating

Dimensions

For cylinder Ø mm	Code	Item	A	B	C	D	G	H	J	R	S	PD	PO	PA	P	P ₁	P ₂	VO	Weight (g)
8	040021	P08-10	12	4,5	25	35	11	16	16	10	3	24	68	73	16	11	5	16	29
10																			
12	040022	P12-16	16	5,5	32	42	14	20	20	12,5	4	32	78	87	20	14	6	20	33
16													86	94					
20	040023	P20-25	22	6,6	40	54	17	25	25	20	5	36	93	100	25	17	8	25	41
25												40	98	109					

Mounting accessories for cylinders

Mountings in steel for cylinders ISO 6432



Main features

8 ÷ 25

Bores Ø



MF8

F

Type

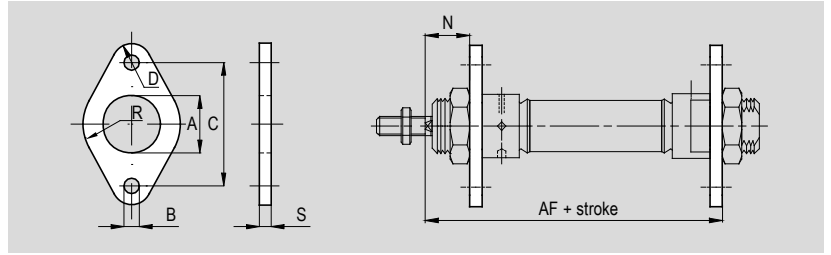

Technical data

Type	Description	Material	Treatment
F..	Mounting for cylinders in steel. Flange. For rear or front mounting (head nut required. One head nut supplied with cylinders as standard). Supplied individually.	Zinc plated steel	White zinc plating

Dimensions

For cylinder Ø mm	Code	Item	A	B	C	R	D	S	N	AF	Weight (g)
8	040001	F08-10	12	4,5	30	11	5	3	13	65	25
10											
12	040002	F12-16	16	5,5	40	15	6	4	18	77	29
16											
20	040003	F20-25	22	6,6	50	20	8	5	19	88	35
25									23		

Mounting accessories for cylinders

Mountings in steel for round cylinders series M



Main features

32 ÷ 63

Bores Ø

P..AQM

Type

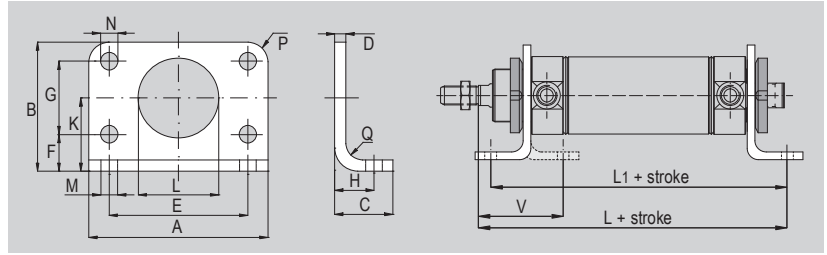

Technical data

Type	Description	Material	Treatment
P..AQM	Mounting for cylinders in steel. Foot-flange. For front or rear mounting (head nut type GH..AQM required, see below. One head nut supplied with cylinders as standard). Supplied individually.	Zinc plated steel	White zinc plating

Dimensions

For cylinder Ø mm	Code	Item	A	B	C	D	E	F	G	H	K	ØL	ØM	ØN	P	Q	V	L	L ₁
32	040054	P032AQM	66	49	21	4	52	14	28	14	28	30	7	7	7	4	48	148	124
40	040055	P040AQM	80	58	30	5	60	18	30	20	33	38	9	9	10	5	60	178	153
50	040056	P050AQM	90	70	30	6	70	20	40	20	40	45	9	9	10	6	64	190	160
63	040057	P063AQM	96	80	30	6	76	20	50	20	45	45	9	9	10	6	65	-	164

Main features

32 ÷ 63

Bores Ø

GH..AQM

Type

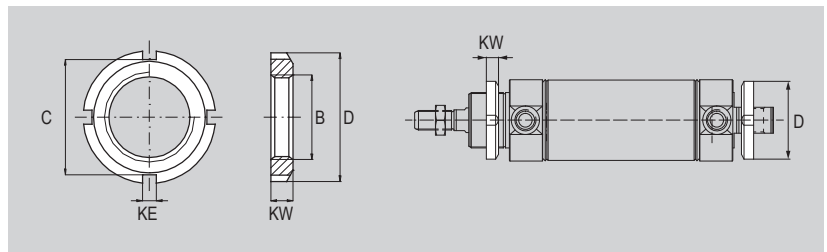

Technical data

Type	Description	Material	Treatment
GH..AQM	Mounting for cylinders in steel. Head nut. For front or rear mounting. Supplied individually.	Zinc plated steel	White zinc plating

Dimensions

For cylinder Ø mm	Code	Item	ØD	B	C	KW	KE
32	040066	GH032AQM	45	M30x1,5	40	7	5
40	040067	GH040AQM	50	M38x1,5	46	8	5
50-63	040068	GH050/063AQM	58	M45x1,5	52	9	6

Mounting accessories for cylinders

Mountings in steel for round cylinders series M



Main features

8 ÷ 25

Bores Ø



MP3

CF..M

Type

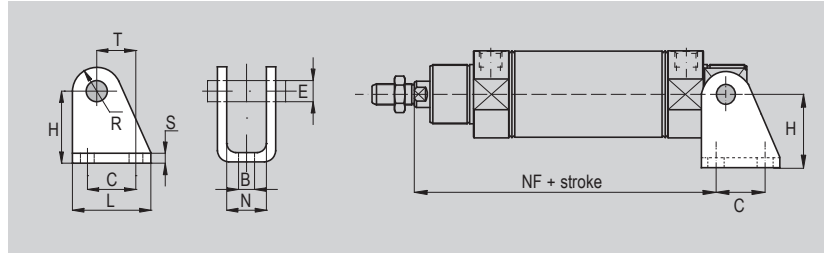

Technical data

Type	Description	Material	Treatment
CF..M	Mounting for cylinders in steel. Rear clevis. Supplied with pin and two seeger.	Zinc plated steel	White zinc plating

Dimensions

For cylinder Ø mm	Code	Item	B	E	C	H	L	N	T	R	S	NF	Weight (g)
32	040212	CF32M	6,6	10	24	35	35	16,1	18,5	11	4	113	106
40	040213	CF40M	9	12	30	40	45	18,1	23,5	13	5	135,1	185
50	040214	CF50-63M	9	16	34	45	50	21,1	28	14	6	143,2	283
63												152,2	

Mounting accessories for cylinders

Mountings in steel for round cylinders series R



Main features

32 ÷ 63

Bores Ø

CF..AQM

Type

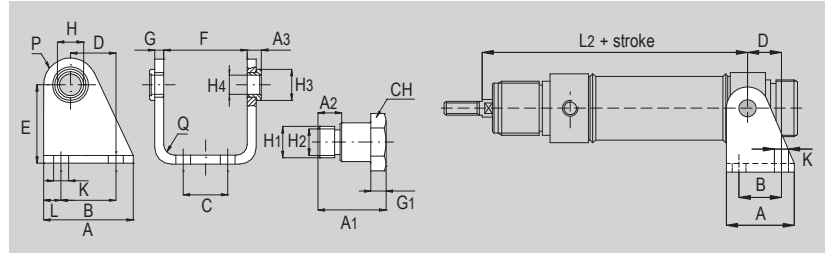

Technical data

Type	Description	Material	Treatment
CF..AQM+P	Mounting for cylinders in steel. Rear clevis. For front or rear mounting. Supplied with two pins.	Zinc plated steel	White zinc plating

Dimensions

For cylinder Ø mm	Code	Item	A	A ₁	A ₂	A ₃	B	C	D	E	F	G	G ₁	H	H ₁	H ₂	H ₃	H ₄	CH	K	L	P	Q	L ₃
32	040058	CF032AQM+P	40	18	6	6	24	20	20	35	38,1	4	4	12	10	M8x1	15	10	13	7	8	12	4	125
40	040059	CF040AQM+P	50	21,6	7	7	30	28	27	40	46,1	5	5	15	12	M10x1	20	12	17	9	10	13	5	146
50	040060	CF050AQM+P	54	26,4	9	8,5	34	36	30	45	57,1	6	6	18	14	M12x1,5	23	14	19	9	10	14	6	158
63	040061	CF063AQM+P	65	31,5	13	8,5	35	42	34	50	70,1	6	6	20	16	M14x1,5	23	16	19	9	15	16	6	161

Main features

32 ÷ 63

Bores Ø

P..AQM

Type

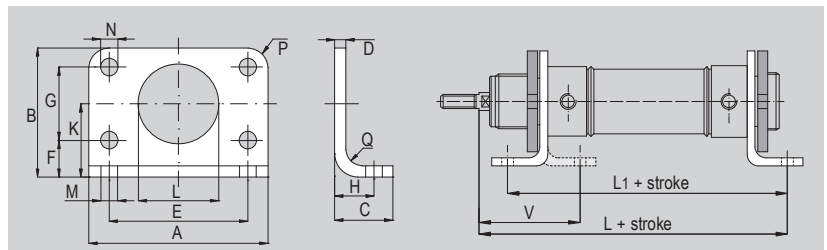

Technical data

Type	Description	Material	Treatment
P..AQM	Mounting for cylinders in steel. Foot-flange. For front or rear mounting (head nut type GH..AQM required, see page 1.96.2. One head nut supplied with cylinders as standard). Supplied individually.	Zinc plated steel	White zinc plating

Dimensions

For cylinder Ø mm	Code	Item	A	B	C	D	E	F	G	H	K	ØL	ØM	ØN	P	Q	V	L	L ₁
32	040054	P032AQM	66	49	21	4	52	14	28	14	28	30	7	7	7	4	48	148	124
40	040055	P040AQM	80	58	30	5	60	18	30	20	33	38	9	9	10	5	60	178	153
50	040056	P050AQM	90	70	30	6	70	20	40	20	40	45	9	9	10	6	64	190	160
63	040057	P063AQM	96	80	30	6	76	20	50	20	45	45	9	9	10	6	65	-	164

Mounting accessories for cylinders

Mountings in steel for round cylinders series R



1 - CYLINDERS

Main features

32 ÷ 63

Bores Ø

CP..AQM

Type

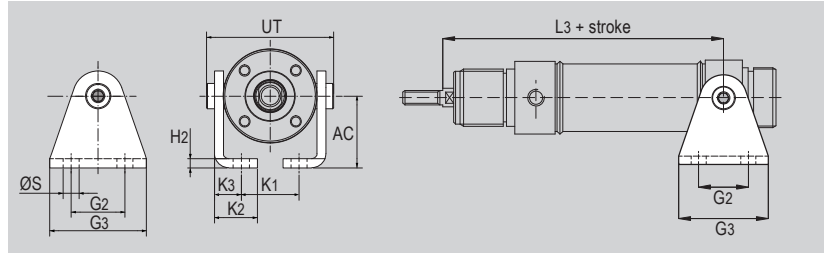

Technical data

Type	Description	Material	Treatment
CP..AQM+P	Mounting for cylinders in steel. Foot-hinges. For front or rear mounting. Kit composed by two foot-hinges and two pins.	Zinc plated steel	White zinc plating

Dimensions

For cylinder Ø mm	Code	Item	ØS	G ₂	G ₃	H ₂	K ₁	K ₂	K ₃	AC	UT	L ₃
32	040170	CP032AQM+P	7	20	35	4	15,5	20	13	25	47	125
40	040171	CP040AQM+P	7	28	42	4	23,5	20	13	28	57	146
50	040172	CP050AQM+P	9	30	54	5	32,3	24	15	40	71	158
63	040173	CP063AQM+P	9	40	64	5	40,5	26,5	17,5	47	84	161

Main features

32 ÷ 63

Bores Ø

GH..AQM

Type

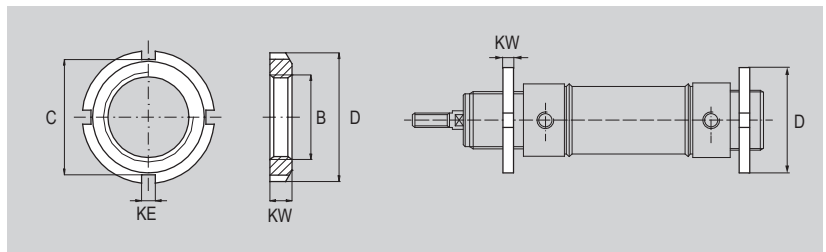

Technical data

Type	Description	Material	Treatment
GH..AQM	Mounting for cylinders in steel. Head nut. For front or rear mounting. Supplied individually.	Zinc plated steel	White zinc plating

Dimensions

For cylinder Ø mm	Code	Item	ØD	B	C	KW	KE
32	040066	GH032AQM	45	M30x1,5	40	7	5
40	040067	GH040AQM	50	M38x1,5	46	8	5
50-63	040068	GH050/063AQM	58	M45x1,5	52	9	6

Mounting accessories for cylinders

Mountings in steel for round cylinders series R



Main features

32 ÷ 63

Bores Ø

SEC..AQM

Type

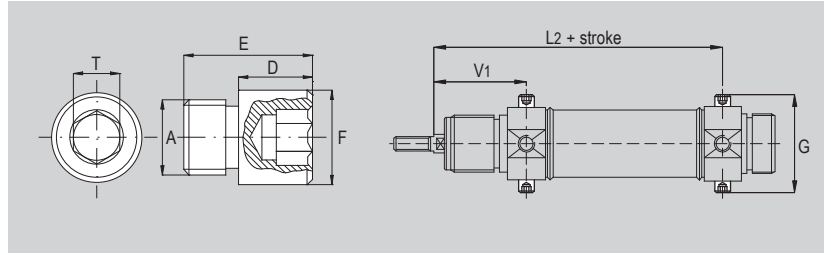

Technical data

Type	Description	Material	Treatment
SEC..AQM	Mounting for cylinders in steel. Pin. For front or rear mounting. Kit composed by two pins.	Zinc plated steel	White zinc plating

Dimensions

For cylinder Ø mm	Code	Item	A	D	E	F	T	G	V ₁	L ₂
32	040062	SEC032AQM	M8x1	8	14	Ø 10	5	51	47	125
40	040063	SEC040AQM	M10x1	9,5	16,5	Ø 12	6	61	57	146
50	040064	SEC050AQM	M12x1,5	11	20	Ø 14	6	75	62	158
63	040065	SEC063AQM	M14x1,5	13	28	Ø 16	8	92	63	161

Mounting accessories for cylinders

Mountings in aluminium for cylinders ISO 15552



Main features

32 ÷ 320



Bores Ø

MP2

Type

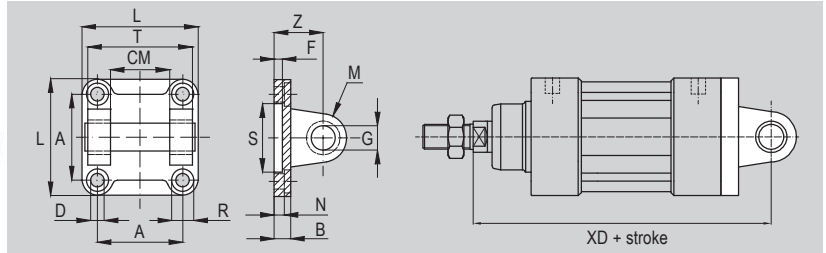

Technical data

Type	Description	Material	Treatment
CF..ALIS+VP	Mounting for cylinders in aluminium. Rear clevis. Supplied with screws and pin.	Die-cast aluminium	Sifting

Dimensions

For cylinder Ø mm	Code	Item	A	L	D	R	N	B	S	F	Z	G	M	CM	T	XD	Weight (g)
32	042050	CF032ALIS+VP	32,5	45	6,6	11	5,5	9	30	5	22	10	10	26	45	142	-
40	042051	CF040ALIS+VP	38	52	6,6	11	5,5	9	35	5	25	12	12	28	52	160	-
50	042052	CF050ALIS+VP	46,5	65	9	15	6,5	11	40	5	27	12	12	32	60	170	-
63	042053	CF063ALIS+VP	56,5	75	9	15	6,5	11	45	5	32	16	16	40	70	190	-
80	042054	CF080ALIS+VP	72	95	11	18	10	14	45	5	36	16	16	50	90	210	-
100	042055	CF100ALIS+VP	89	115	11	18	10	14	55	5	41	20	20	60	110	230	-
125	042056	CF125ALIS+VP	110	140	14	20	10	20	60	7	50	25	25	70	130	275	-
160	042057	CF160ALIS+VP	140	180	18	26	10	20	65	7	55	30	25	90	170	315	-
200	042058	CF200ALIS+VP	175	220	18	26	11	25	75	7	60	30	25	90	170	335	-
250	042059	CF250ALIS+VP	220	270	22	33	11	25	90	11	70	40	40	110	200	375	-
320	042060	CF320ALIS+VP	270	350	26	39	15	30	110	11	80	45	45	120	220	420	-

Main features

32 ÷ 320



Bores Ø

MP2

Type

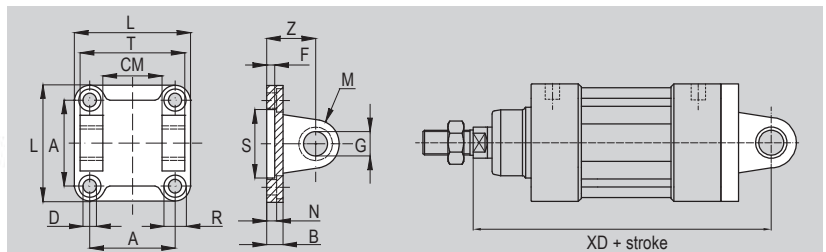

Technical data

Type	Description	Material	Treatment
CF..ALIS+V	Mounting for cylinders in aluminium. Rear clevis. Supplied with screws.	Die-cast aluminium	Sifting

Dimensions

For cylinder Ø mm	Code	Item	A	L	D	R	N	B	S	F	Z	G	M	CM	T	XD	Weight (g)
32	040441	CF032ALIS+V	32,5	45	6,6	11	5,5	9	30	5	22	10	10	26	45	142	-
40	040442	CF040ALIS+V	38	52	6,6	11	5,5	9	35	5	25	12	12	28	52	160	-
50	040443	CF050ALIS+V	46,5	65	9	15	6,5	11	40	5	27	12	12	32	60	170	-
63	040444	CF063ALIS+V	56,5	75	9	15	6,5	11	45	5	32	16	16	40	70	190	-
80	040445	CF080ALIS+V	72	95	11	17	10	14	45	5	36	16	16	50	90	210	-
100	040446	CF100ALIS+V	89	115	11	18	10	14	55	5	41	20	20	60	110	230	-
125	040447	CF125ALIS+V	110	140	14	20	10	20	60	7	50	25	25	70	130	275	-
160	040448	CF160ALIS+V	140	180	18	26	10	20	65	7	55	30	25	90	170	315	-
200	040449	CF200ALIS+V	175	220	18	26	11	25	75	7	60	30	25	90	170	335	-
250	040450	CF250ALIS+V	220	270	22	33	11	25	90	11	70	40	40	110	200	375	-
320	040459	CF320ALIS+V	270	350	26	39	15	30	110	11	80	45	45	120	220	420	-

Mounting accessories for cylinders

Mountings in aluminium for cylinders ISO 15552



1 - CYLINDERS

Main features

32 ÷ 250  CFS..ALIS+VP
Bores Ø AB6 Type

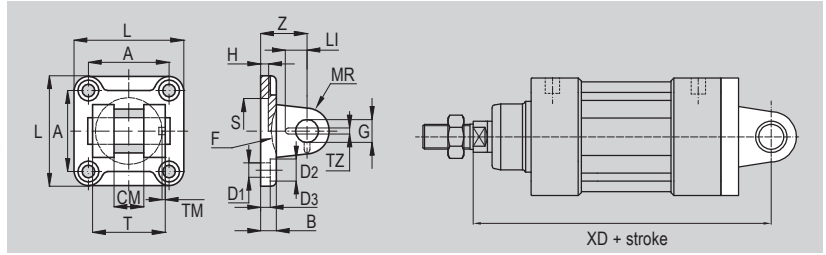

Technical data

Type	Description	Material	Treatment
CFS..ALIS+VP	Mounting for cylinders in aluminium. Narrow rear clevis (for DIN 648K bearings). Supplied with screws and anti-rotating pin.	Die-cast aluminium	Sifting

Dimensions

For cylinder Ø mm	Code	Item	L	T	CM	A	Z	H	B	D ₃	S	G	MR	D ₁	D ₂	TM	TZ	LI	F	XD	Weight (g)
32	042110	CFS032ALIS+VP	45	34	14	32,5	22	5	9	5,5	30	10	10	6,6	11	3	3,3	11,5	17	142	-
40	042111	CFS040ALIS+VP	52	40	16	38	25	5	9	5,5	35	12	12	6,6	11	4	4,3	12	20	160	-
50	042112	CFS050ALIS+VP	65	45	21	46,5	27	5	11	6,5	40	16	14	9	15	4	4,3	14	22	170	-
63	042113	CFS063ALIS+VP	75	51	21	56,5	32	5	11	6,5	45	16	18	9	15	4	4,3	14	25	190	-
80	042114	CFS080ALIS+VP	95	65	25	72	36	5	14	10	45	20	20	11	18	4	4,3	16	30	210	-
100	042115	CFS100ALIS+VP	115	75	25	89	41	5	14	10	55	20	22	11	18	4	6,3	16	32	230	-
125	042116	CFS125ALIS+VP	140	97	37	110	50	7	20	10	60	30	25	14	20	6	6,3	24	42	275	-
160	042117	CFS160ALIS+VP	180	122	43	140	55	7	20	10	65	35	30	18	26	6	6,3	26,5	46	315	-
200	042118	CFS200ALIS+VP	220	122	43	175	60	7	25	11	75	35	30	18	26	6	6,3	26,5	49	335	-
250	042148	CFS250ALIS+VP	270	125	49	220	70	11	25	11	90	40	40	22	33	8,5	8,3	32	55	375	-

Main features

32 ÷ 250  CFS..ALIS+V
Bores Ø AB6 Type

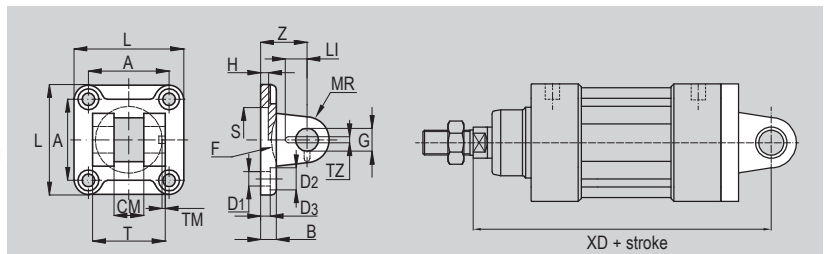

Technical data

Type	Description	Material	Treatment
CFS..ALIS+V	Mounting for cylinders in aluminium. Narrow rear clevis (for DIN 648K bearings). Supplied with screws.	Die-cast aluminium	Sifting

Dimensions

For cylinder Ø mm	Code	Item	L	T	CM	A	Z	H	B	D ₃	S	G	MR	D ₁	D ₂	TM	TZ	LI	F	XD	Weight (g)
32	040451	CFS032ALIS+V	45	34	14	32,5	22	5	9	5,5	30	10	10	6,6	11	3	3,3	11,5	17	142	-
40	040452	CFS040ALIS+V	52	40	16	38	25	5	9	5,5	35	12	12	6,6	11	4	4,3	12	20	160	-
50	040453	CFS050ALIS+V	65	45	21	46,5	27	5	11	6,5	40	16	14	9	15	4	4,3	14	22	170	-
63	040454	CFS063ALIS+V	75	51	21	56,5	32	5	11	6,5	45	16	18	9	15	4	4,3	14	25	190	-
80	040455	CFS080ALIS+V	95	65	25	72	36	5	14	10	45	20	20	11	18	4	4,3	16	30	210	-
100	040456	CFS100ALIS+V	115	75	25	89	41	5	14	10	55	20	22	11	18	4	6,3	16	32	230	-
125	040457	CFS125ALIS+V	140	97	37	110	50	7	20	10	60	30	25	14	20	6	6,3	24	42	275	-
160	040458	CFS160ALIS+V	180	122	43	140	55	7	20	10	65	35	30	18	26	6	6,3	26,5	46	315	-
200	040498	CFS200ALIS+V	220	122	43	175	60	7	25	11	75	35	30	18	26	6	6,3	26,5	49	335	-
250	040499	CFS250ALIS+V	270	125	49	220	70	11	25	11	90	40	40	22	33	8,5	8,3	32	55	375	-

Mounting accessories for cylinders

Mountings in aluminium for cylinders ISO 15552



Main features

32 ÷ 320



Bores Ø

MP4

Type

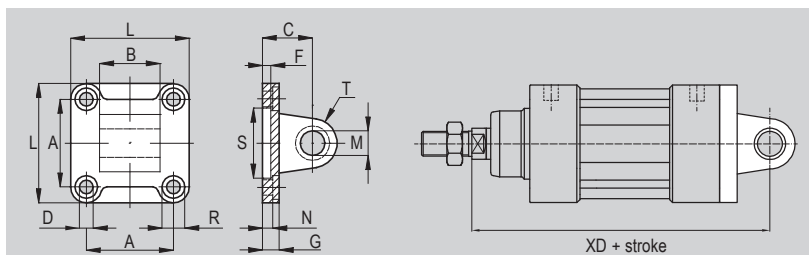

Technical data

Type	Description	Material	Treatment
CM..ALIS+V	Mounting for cylinders in aluminium. Rear eye. Supplied with screws.	Die-cast aluminium	Sifting

Dimensions

For cylinder Ø mm	Code	Item	A	L	D	R	N	G	S	F	C	M	T	B	XD	Weight (g)	
32	042061	CM032ALIS+V	32,5	45	6,6	11	5,5	9	30	5	22	10	10	26	-0,2 -0,6	142	-
40	042062	CM040ALIS+V	38	52	6,6	11	5,5	9	35	5	25	12	12	28		160	-
50	042063	CM050ALIS+V	46,5	65	9	15	6,5	11	40	5	27	12	12	32		170	-
63	042064	CM063ALIS+V	56,5	75	9	15	6,5	11	45	5	32	16	16	40		190	-
80	042065	CM080ALIS+V	72	95	11	18	10	14	45	5	36	16	16	50		210	-
100	042066	CM100ALIS+V	89	115	11	18	10	14	55	5	41	20	20	60	230	-	
125	042067	CM125ALIS+V	110	140	14	20	10	20	60	7	50	25	25	70	275	-	
160	042068	CM160ALIS+V	140	180	18	26	10	20	65	7	55	30	25	90	315	-	
200	042069	CM200ALIS+V	175	220	18	26	11	25	75	7	60	30	25	90	335	-	
250	042070	CM250ALIS+V	220	270	22	33	11	25	90	11	70	40	40	110	375	-	
320	042071	CM320ALIS+V	270	350	26	39	15	30	110	11	80	50	45	120	420	-	

Main features

32 ÷ 200



Bores Ø

MP7

Type

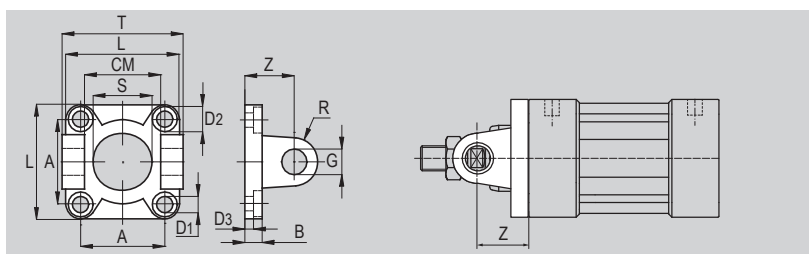

Technical data

Type	Description	Material	Treatment
CFA..ALIS+V	Mounting for cylinders in aluminium. Front clevis. Supplied with screws.	Die-cast aluminium	Sifting

Dimensions

For cylinder Ø mm	Code	Item	A	T	D ₁	D ₂	D ₃	B	S	Z	G	R	CM	L	Weight (g)
32	040473	CFA032ALIS+V	32,5	45	6,6	11	5,5	9	30	22	10	10	26	45	74
40	040474	CFA040ALIS+V	38	52	6,6	11	5,5	9	35	25	12	12	28	52	101
50	040017	CFA050ALIS+V	46,5	60	9	15	6,5	11	40	27	12	12	32	65	178
63	040471	CFA063ALIS+V	56,5	70	9	15	6,5	11	45	32	16	16	40	75	246
80	040051	CFA080ALIS+V	72	90	11	18	10	14	45	36	16	16	50	95	482
100	040478	CFA100ALIS+V	89	110	11	18	10	14	55	41	20	20	60	115	722
125	040475	CFA125ALIS+V	110	130	14	20	10	20	60	50	25	25	70	140	1323
160	040477	CFA160ALIS+V	140	170	18	26	10	20	65	55	30	25	90	180	2090
200	040479	CFA200ALIS+V	175	170	18	26	11	25	75	60	30	25	90	220	3210

Mounting accessories for cylinders

Mountings in aluminium for cylinders ISO 15552



1 - CYLINDERS

Main features

32 ÷ 320 CMS..ALIS+V
Bores Ø MP6 Type

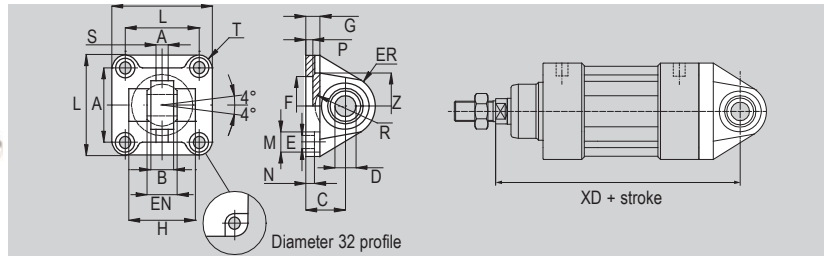

Technical data

Type	Description	Material	Treatment
CMS..ALIS+V	Mounting for cylinders in aluminium. Narrow rear eye with spherical bearing DIN 648K. Supplied with screws.	Die-cast aluminium	Sifting

Dimensions

For cylinder Ø mm	Code	Item	A	B	C	D	EN	ER	F	G	E	L	M	N	P	H	R	S	Z	T	XD	Weight (g)
32	042101	CMS032ALIS+V	32,5	10,5	22	10	14	16	30	9	6,6	45	11	5,5	5	-	-	4	32,5	6,25	142	-
40	042102	CMS040ALIS+V	38	12	25	12	16	19	35	9	6,6	52	11	5,5	5	-	-	6	39	7	160	-
50	042103	CMS050ALIS+V	46,5	15	27	16	21	21	40	11	9	65	15	6,5	5	51	18	8	47	9,25	170	-
63	042104	CMS063ALIS+V	56,5	15	32	16	21	24	45	11	9	75	15	6,5	5	-	-	8	52	9,25	190	-
80	042105	CMS080ALIS+V	72	18	36	20	25	28,5	45	14	11	95	18	10	5	72	24	10	67	11,5	210	-
100	042106	CMS100ALIS+V	89	18	41	20	25	30	55	14	11	115	18	10	5	-	-	10	77	13	230	-
125	042107	CMS125ALIS+V	110	25	50	30	37	40	60	20	13,5	140	20	10	7	-	-	13	98	15	275	-
160	042108	CMS160ALIS+V	140	28	55	35	43	45	65	20	18	180	26	10	7	-	-	14	130	20	315	-
200	042109	CMS200ALIS+V	175	28	60	35	43	48	75	25	18	220	26	11	7	-	-	14	155	22,5	335	-
250	040160	CMS250ALIS+V	220	33	70	40	49	52	90	25	22	270	33	11	11	-	-	19	205	25	375	-
320	040197	CMS320ALIS+V	270	45	80	50	60	63	110	30	22	350	33	11	11	-	-	-	-	28	420	-

Main features

32 ÷ 200 FLV..ALIS+V
Bores Ø Type
MF1/MF2

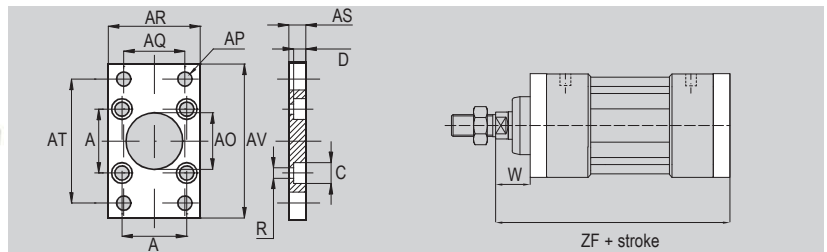

Technical data

Type	Description	Material	Treatment
FLV..ALIS+V	Mounting for cylinders in aluminium. Flange. For front or rear mounting. Supplied with screws.	Die-cast aluminium	Anodizing

Dimensions

For cylinder Ø mm	Code	Item	A	ØAP	AO	R	AS	AR	AQ	AT	AV	C	D	ZF	W	Weight (g)
32	042150	FLV032ALIS+V	32,5	7	30	6,5	10	45	32	64	86	10,5	5	130	16	-
40	042151	FLV040ALIS+V	38	9	35	6,5	10	52	36	72	96	11	5	145	20	-
50	042152	FLV050ALIS+V	46,5	9	40	9	12	65	45	90	115	15	5,5	155	25	-
63	042153	FLV063ALIS+V	56,5	9	45	9	12	75	50	100	130	15	5,5	170	25	-
80	042154	FLV080ALIS+V	72	12	45	11	16	95	63	126	165	18	7	190	30	-
100	042155	FLV100ALIS+V	89	14	55	11	16	115	75	150	187	18	7	205	35	-
125	042156	FLV125ALIS+V	110	16	60	13	20	140	90	180	224	19	9,5	245	45	-
160	042157	FLV160ALIS+V	140	18	65	17	20	180	115	230	280	25	10,5	280	60	-
200	042158	FLV200ALIS+V	175	22	75	17	25	220	135	270	320	25	12,5	300	70	-

Mounting accessories for cylinders

Mountings in aluminium for cylinders ISO 15552



Main features

32 ÷ 250



Bores Ø

AB7

Type

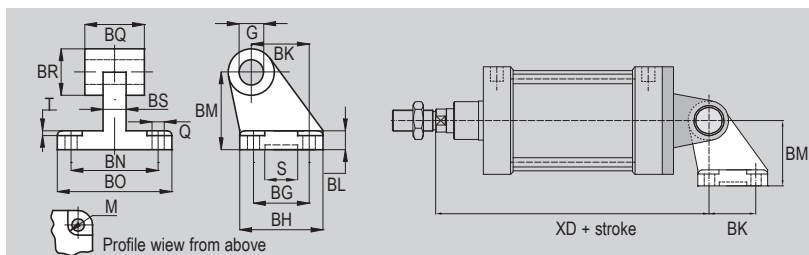

Technical data

Type	Description	Material	Treatment
ASV..ALIS+V	Mounting for cylinders in aluminium. Rear 90° hinge. For mounting with rear female clevis type CF. Supplied with screws.	Die-cast aluminium	Sifting

Dimensions

For cylinder Ø mm	Code	Item	Q	M	BG	BH	BK	BL	BM	BN	BO	BS	BR	G	T	S	BQ	XD	Weight (g)	
32	042081	ASV032ALIS+V	6,6	11	18	31	21	8	32	38	51	10	20	10	1,6	10,5	26	-0,2	142	56
40	042082	ASV040ALIS+V	6,6	11	22	35	24	10	36	41	54	15	22	12	1,6	10,5	28	-0,6	160	139
50	042083	ASV050ALIS+V	9	15	30	45	33	12	45	50	65	16	26	12	1,6	10,5	32	-0,5	170	142
63	042084	ASV063ALIS+V	9	15	35	50	37	14	50	52	67	16	30	16	1,6	10,5	40	-1,2	190	200
80	042085	ASV080ALIS+V	11	18	40	60	47	14	63	66	86	20	30	16	2,5	10,5	50	-0,2	210	312
100	042086	ASV100ALIS+V	11	18	50	70	55	17	71	76	96	20	38	20	2,5	10,5	60	-0,5	230	656
125	042087	ASV125ALIS+V	14	20	60	90	70	20	90	94	124	30	45	25	3,2	10,5	70	-1,2	275	826
160	042088	ASV160ALIS+V	14	20	88	126	97	25	115	118	156	36	63	30	4	-	90	-0,5	315	2600
200	042089	ASV200ALIS+V	18	26	90	130	105	30	135	122	162	40	63	40	4	-	90	-1,2	335	3250
250	042090	ASV250ALIS+V	22	33	110	160	128	35	165	150	200	45	80	42	4,5	-	110	-0,2	375	5700

Main features

32 ÷ 250



Bores Ø

RP 107P

Type

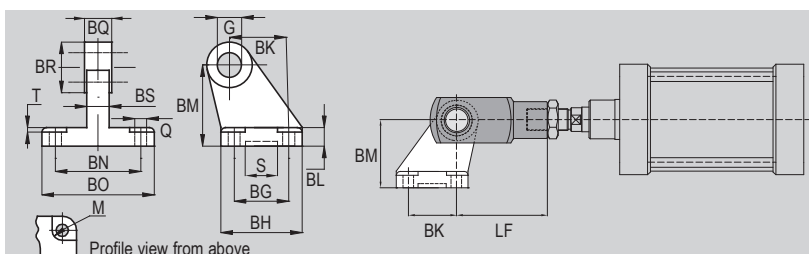

Technical data

Type	Description	Material	Treatment
ASF..ALIS	Mounting for cylinders in aluminium. Clevis hinge. For mounting with rod clevis type FF.	Die-cast aluminium	Sifting

Dimensions

For cylinder Ø mm	Code	Item	Q	M	BG	BH	BK	BL	BM	BN	BO	BS	BR	G	T	S	BQ	LF	Weight (g)	
32	042161	ASF032ALIS+V	6,6	11	18	31	21	8	32	38	51	9,4	20	10	1,6	10,5	10	-	40	69
40	042162	ASF040ALIS+V	6,6	11	22	35	24	10	36	41	54	15	-	12	1,6	10,5	12	-	40	94
50	042163	ASF050ALIS+V	9	15	30	45	33	12	45	50	65	15,4	26	16	1,6	10,5	16	-	48	169
63	042164	ASF063ALIS+V	9	15	35	50	37	14	50	52	67	15,4	30	16	1,6	10,5	16	-	64	223
80	042165	ASF080ALIS+V	11	18	40	60	47	14	63	66	86	19,4	30	20	2,5	10,5	20	-0,2	64	362
100	042166	ASF100ALIS+V	11	18	50	70	55	17	71	76	96	19,4	38	20	2,5	10,5	20	-0,6	80	528
125	042167	ASF125ALIS+V	14	20	60	90	70	20	90	94	124	30	45	25/30	3,2	10,5	25/30	-	110	943
160	042168	ASF160ALIS+V	14	20	88	126	97	25	115	118	156	36	63	35	4	-	35	-	144	2810
200	042169	ASF200ALIS+V	18	26	90	130	105	30	135	122	162	40	63	35	4	-	35	-	144	3410
250	042170	ASF250ALIS+V	22	33	110	160	128	35	165	150	200	45	80	42	4,5	-	42	-	168	6580

Mounting accessories for cylinders

Mountings in aluminium for cylinders ISO 15552



Main features

32 ÷ 200 AS..ALIS
Bores Ø 6431 Type

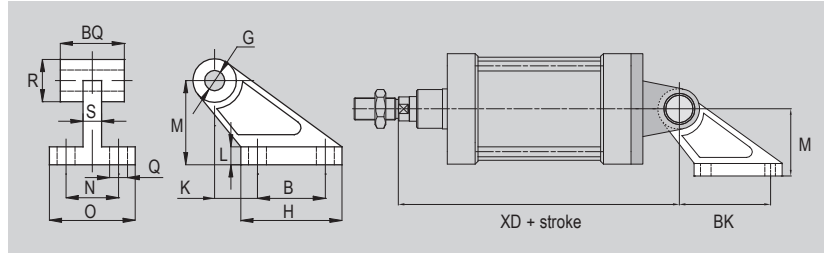

Technical data

Type	Description	Material	Treatment
AS..ALIS	Mountings for cylinders in aluminium. Rear 90° hinge. For mounting with rear female clevis type CF. Mounting screws to be ordered separately see page 1.101.1	Die-cast aluminium	Sifting

Dimensions

For cylinder Ø mm	Code	Item	Q	B	H	K	L	M	N	O	S	R	BQ	G	XD	BK	Weight (g)
32	040361	AS032ALIS	7	20	37	18	8	32	25	41	9	19	26	10	142	38	54
40	040362	AS040ALIS	9	32	54	25	10	45	32	52	14	25,5	28	12	160	57	136
50	040363	AS050ALIS	9	32	54	25	10	45	32	52	14	25,5	32	12	170	57	140
63	040364	AS063ALIS	11	50	75	32	12	63	40	63	14	32	40	16	190	82	295
80	040365	AS080ALIS	11	50	75	32	12	63	40	63	14	32	50	16	210	82	313
100	040366	AS100ALIS	14	70	103	40	17	90	50	80	22	42	60	20	230	110	710
125	040367	AS125ALIS	14	70	103	40	17	90	50	80	22	46	70	25	275	110	820
160	040368	AS160ALIS	18	110	154	50	20	140	63	110	26	53,5	89	30	315	160	1974
200	040369	AS200ALIS	18	110	154	50	20	140	63	110	26	53,5	89	30	335	160	1974

Main features

32 ÷ 200 P..ALIS
Bores Ø MS3 Type

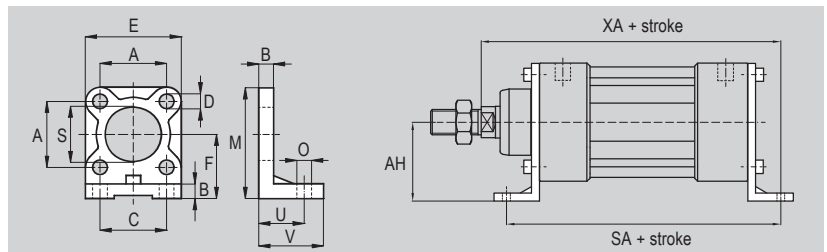

Technical data

Type	Description	Material	Treatment
P..ALIS	Mounting for cylinders in aluminium. Foot. For front or rear mounting. Supplied individually. Mounting screws to be ordered separately see page 1.101.1	Die-cast aluminium	Sifting

Dimensions

For cylinder Ø mm	Code	Item	A	B	C	D	E	F	M	O	S	U	V	AH	XA	SA	Weight (g)
32	040141	P032ALIS	32,5	8	32	7	40	32	54,5	7	30	24	35	31,5	154	138	46
40	040142	P040ALIS	38	8	36	7	52	36	62	9	35	28	35	34	173	161	66
50	040143	P050ALIS	46,5	10	45	9	65	45	77,5	9	40	32	45	42,5	187	170	138
63	040144	P063ALIS	56,5	10	50	9	75	50	87,5	9	45	32	45	47,5	202	185	174
80	040145	P080ALIS	72	12	63	11	95	63	110,5	12	45	41	55	59,5	231	210	356
100	040146	P100ALIS	89	12	75	11	115	71	128	14	55	41	56	69,5	246	220	468
125	040147	P125ALIS	110	16	90	14	140	91	161	16	60	45	68	86	290	250	920
160	040148	P160ALIS	140	20	115	18	180	115	205	18	65	60	82	110	340	300	2300
200	040149	P200ALIS	175	20	135	18	220	135	245	22	75	70	90	130	370	320	3200

Mounting accessories for cylinders

Mountings in steel for cylinders ISO 15552



Main features

32 ÷ 320 **ISO** CF..AQIS+V

Bores Ø MP2 Type

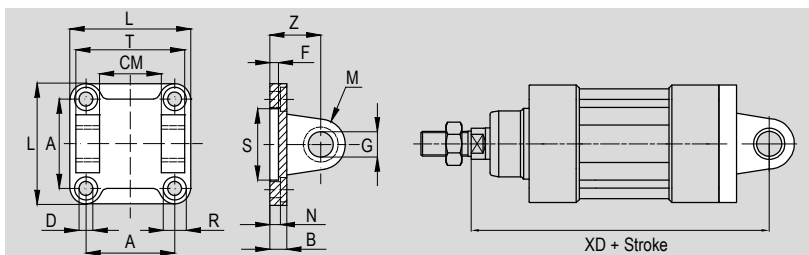

Technical data

Type	Description	Material	Treatment
CF..AQIS+V	Mounting for cylinders in steel. Rear clevis. Supplied with screws. Pin type SEC..AQIS to be ordered separately, see page 1.98.5	Steel A 105	Black cataphoresis

Dimensions

For cylinder Ø mm	Code	Item	A	L	D	R	N	B	S	F	Z	G	M	CM	T	XD	Weight (g)
32	040461	CF032AQIS+V	32,5	45	6,6	11	5,5	10	30	5	22	10	10	26	45	142	164
40	040462	CF040AQIS+V	38	55	6,6	11	5,5	10	35	5	25	12	12	28	52	160	256
50	040463	CF050AQIS+V	46,5	65	9	15	6,5	10	40	5	27	12	12	32	60	170	392
63	040464	CF063AQIS+V	56,5	75	9	15	6,5	12	45	5	32	16	16	40	70	190	594
80	040465	CF080AQIS+V	72	95	11	18	10	14	45	-	36	16	16	50	90	210	1102
100	040466	CF100AQIS+V	89	115	11	18	10	16	55	-	41	20	20	60	110	230	1802
125	040467	CF125AQIS+V	110	140	14	20	10	20	60	-	50	25	25	70	130	275	3493
160	040468	CF160AQIS+V	140	180	18	26	10	20	65	7	55	30	25	90	170	315	6060
200	040469	CF200AQIS+V	175	220	18	26	11	20	75	7	60	30	25	90	170	335	9210
250	040480	CF250AQIS+V	220	270	22	33	11	25	90	11	70	40	40	110	200	375	16460
320	040470	CF320AQIS+V	270	350	26	39	15	30	110	11	80	45	45	120	220	420	31830

Main features

32 ÷ 125 **ISO** CFS..AQIS+V

Bores Ø AB6 Type

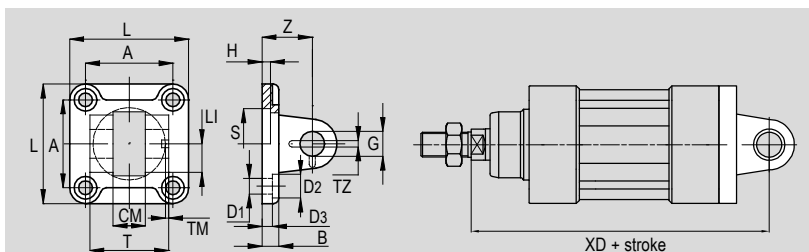

Technical data

Type	Description	Material	Treatment
CFS..AQIS+V	Mounting for cylinders in steel. Narrow rear clevis. Supplied with screws. Anti-rotating pin type SEC..ARAQIS to be ordered separately, see page 1.98.5	Steel A 105	Black cataphoresis

Dimensions

For cylinder Ø mm	Code	Item	L	T	CM	A	Z	H	B	D ₃	S	G	D ₁	D ₂	TM	TZ	LI	XD	Weight (g)
32	040491	CFS032AQIS+V	45	34	14	32,5	22	5	10	5,5	30	10	6,6	11	3	3,3	11,5	142	166
40	040492	CFS040AQIS+V	55	40	16	38	25	5	10	5,5	35	12	6,6	11	4	4,3	12	160	256
50	040493	CFS050AQIS+V	65	45	21	46,5	27	5	10	6,5	40	16	9	15	4	4,3	14	170	390
63	040494	CFS063AQIS+V	75	51	21	56,5	32	5	12	6,5	45	16	9	15	4	4,3	14	190	600
80	040495	CFS080AQIS+V	95	65	25	72	36	5	14	10	45	20	11	18	4	4,3	16	210	1292
100	040496	CFS100AQIS+V	115	75	25	89	41	5	16	10	55	20	11	18	4	6,3	16	230	1942
125	040497	CFS125AQIS+V	140	97	37	110	50	7	20	10	60	30	14	20	6	6,3	24	275	3693

Mounting accessories for cylinders

Mountings in steel for cylinders ISO 15552



1 - CYLINDERS

Main features

32 ÷ 320 **ISO** CM..AQIS+V
 Bores Ø MP4 Type

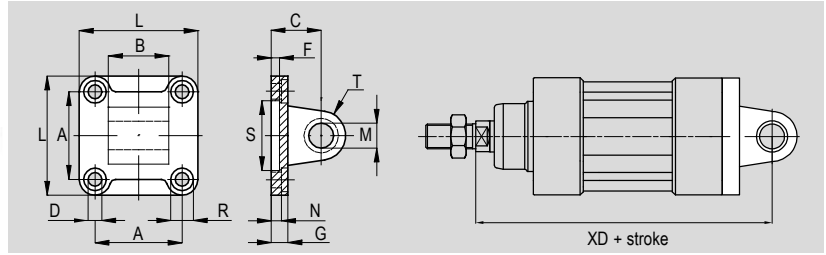

Technical data

Type	Description	Material	Treatment
CM..AQIS+V	Mounting for cylinders in steel. Rear eye. Supplied with screws.	Steel A 105	Black cataphoresis

Dimensions

For cylinder Ø mm	Code	Item	A	L	D	R	N	G	S	F	C	M	T	B	XD	Weight (g)	
32	040521	CM032AQIS+V	32,5	45	6,6	11	5,5	10	30	5	22	10	10	26	-0,2 -0,6	142	202
40	040522	CM040AQIS+V	38	55	6,6	11	5,5	10	35	5	25	12	12	28		160	300
50	040523	CM050AQIS+V	46,5	65	9	15	6,5	10	40	5	27	12	12	32		170	422
63	040524	CM063AQIS+V	56,5	75	9	15	6,5	12	45	5	32	16	16	40		190	736
80	040525	CM080AQIS+V	72	95	11	18	10	14	45	5	36	16	16	50		210	1298
100	040526	CM100AQIS+V	89	115	11	18	10	16	55	5	41	20	20	60		230	2202
125	040527	CM125AQIS+V	110	140	14	20	10	20	60	7	50	25	25	70	-0,5 -1,2	275	3883
160	040528	CM160AQIS+V	140	180	18	26	10	20	65	7	55	30	25	90		315	6200
200	040529	CM200AQIS+V	175	220	18	26	11	20	75	7	60	30	25	90		335	8780
250	040530	CM250AQIS+V	220	270	22	33	11	25	90	11	70	40	40	110		375	17410
320	040539	CM320AQIS+V	270	350	26	39	15	30	110	11	80	45	45	120		420	32830

Main features

32 ÷ 125 **ISO** CMS..AQIS+V
 Bores Ø MP6 Type

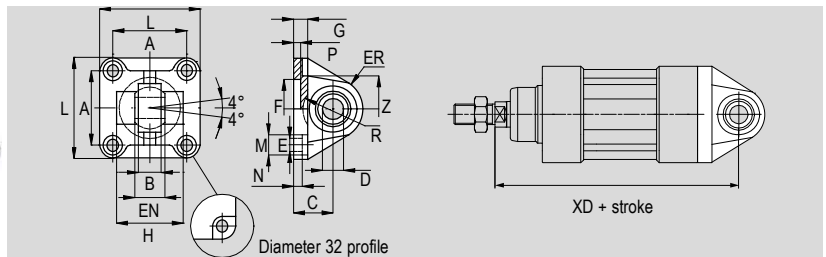

Technical data

Type	Description	Material	Treatment
CMS..AQIS+V	Mounting for cylinders in steel. Narrow rear eye with spherical bearing DIN 648K. Supplied with screws.	Steel A 105	Black cataphoresis

Dimensions

For cylinder Ø mm	Code	Item	A	B	C	D	EN	ER	F	G	E	L	M	N	P	H	R	Z	XD	Weight (g)
32	040531	CMS032AQIS+V	32,5	10,5	22	10	14	15	30	10	6,6	45	11	5,5	5	-	-	32,5	142	178
40	040532	CMS040AQIS+V	38	12	25	12	16	18	35	10	6,6	55	11	5,5	5	-	-	39	160	282
50	040533	CMS050AQIS+V	46,5	15	27	16	21	20	40	10	9	65	15	6,5	5	51	19	47	170	418
63	040534	CMS063AQIS+V	56,5	15	32	16	21	23	45	12	9	75	15	6,5	5	-	-	52	190	649
80	040535	CMS080AQIS+V	72	18	36	20	25	27	45	14	11	95	18	10	5	70	24	67	210	1224
100	040536	CMS100AQIS+V	89	18	41	20	25	30	55	16	11	115	18	10	5	-	-	77	230	1888
125	040537	CMS125AQIS+V	110	25	50	30	37	40	60	20	13,5	140	20	10	7	-	-	98	275	3643

Mounting accessories for cylinders

Mountings in steel for cylinders ISO 15552



Main features

32 ÷ 125 **ISO** ASV..AQIS
 Bores Ø AB7 Type
cetop
 RP 107P

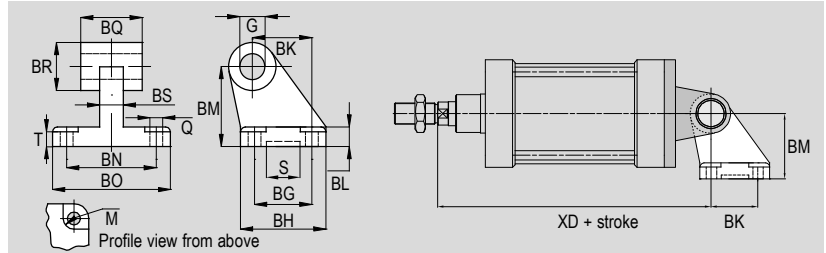

Technical data

Type	Description	Material	Treatment
ASV..AQIS	Mounting for cylinders in steel. Rear 90° hinge. For mounting with rear female clevis type CF. Mounting screws to be ordered separately, see page 1.101.1.	Steel A 105	Black cataphoresis

Dimensions

For cylinder Ø mm	Code	Item	Q	M	BG	BH	BK	BL	BM	BN	BO	BS	BR	G	T	S	BQ	XD	Weight (g)
32	040381	ASV032AQIS	6,6	11	18	31	21	8	32	38	51	10	20	10	6,5	20	26	142	184
40	040382	ASV040AQIS	6,6	11	22	35	24	10	36	41	54	10	22	12	8,5	20	28	160	264
50	040383	ASV050AQS	9	15	30	45	33	12	45	50	65	14	26	12	10,5	20	32	170	472
63	040384	ASV063AQIS	9	15	35	50	37	12	50	52	67	14	30	16	10,5	20	40	190	580
80	040385	ASV080AQIS	11	18	40	60	47	14	63	66	86	18	30	16	11,5	20	50	210	1157
100	040386	ASV100AQIS	11	18	50	70	55	15	71	76	96	20	36	20	12,5	20	60	230	1612
125	040387	ASV125AQIS	14	20	60	90	70	20	90	94	124	30	45	25	17	20	70	275	3293

Main features

32 ÷ 125 **ISO** ASS..AQIS
 Bores Ø CS7 Type

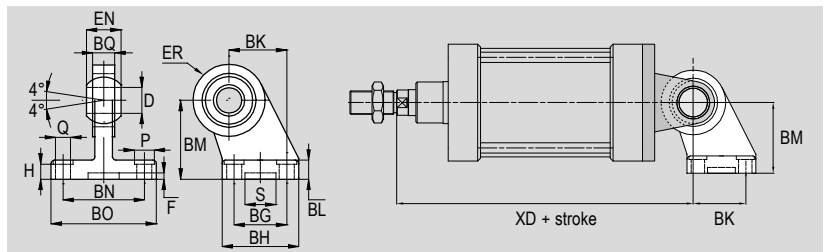

Technical data

Type	Description	Material	Treatment
ASS..AQIS	Mounting for cylinders in steel. Rear 90° hinge with spherical bearing DIN 648K. For mounting with rear female clevis type CFS. Mounting screws to be ordered separately see page 1.101.1.	Steel A 105	Black cataphoresis

Dimensions

For cylinder Ø mm	Code	Item	Q	P	BG	BH	BK	BL	BM	BN	BO	EN	ER	BQ	D	H	S	F	XD	Weight (g)
32	040551	ASS032AQIS	6,6	11	18	31	21	10	32	38	51	14	15	10,5	10	8,5	20	3	142	178
40	040552	ASS040AQIS	6,6	11	22	35	24	10	36	41	54	16	18	12	12	8,5	20	3	160	268
50	040553	ASS050AQS	9	15	30	45	33	12	45	50	65	21	20	15	16	10,5	20	3	170	458
63	040554	ASS063AQIS	9	15	35	50	37	12	50	52	67	21	23	15	16	10,5	20	3	190	550
80	040555	ASS080AQIS	11	18	40	60	47	14	63	66	86	25	27	18	20	11,5	20	3	210	970
100	040556	ASS100AQIS	11	18	50	70	55	15	71	76	96	25	30	18	20	12,5	20	3	230	1326
125	040557	ASS125AQIS	13,5	20	60	90	70	20	90	94	124	37	40	25	30	17	20	3	275	3000

Mounting accessories for cylinders

Mountings in steel for cylinders ISO 15552



1 - CYLINDERS

Main features

32 ÷ 320 **ISO** FLV..AQIS+V
 Bores Ø **VDMA** Type MF1/MF2

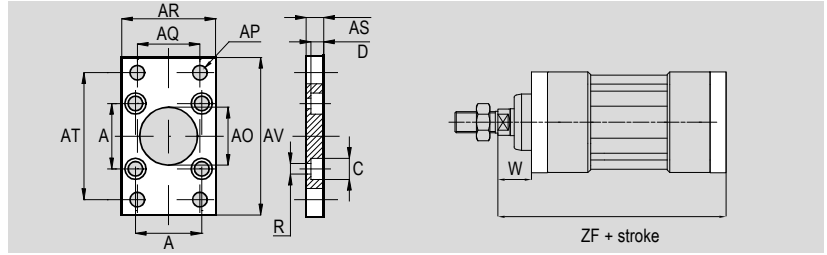

Technical data

Type	Description	Material	Treatment
FLV..AQIS+V	Mounting for cylinders in steel. Flange. For front or rear mounting. Supplied with screws.	Fe 37	White zinc plating

Dimensions

For cylinder Ø mm	Code	Item	A	ØAP	AO	R	AS	AR	AQ	AT	AV	C	D	ZF	W	Weight (g)
32	042119	FLV032AQIS+V	32,5	7	30	6,5	10	45	32	64	86	10,5	5	130	16	-
40	042120	FLV040AQIS+V	38	9	35	6,5	10	52	36	72	96	11	5	145	20	-
50	042121	FLV050AQIS+V	46,5	9	40	9	12	65	45	90	115	15	5,5	155	25	-
63	042122	FLV063AQIS+V	56,5	9	45	9	12	75	50	100	130	15	5,5	170	25	-
80	042123	FLV080AQIS+V	72	12	45	11	16	95	63	126	165	18	7	190	30	-
100	042124	FLV100AQIS+V	89	14	55	11	16	115	75	150	187	18	7	205	35	-
125	042125	FLV125AQIS+V	110	16	60	13	20	140	90	180	224	19	9,5	245	45	-
160	042126	FLV160AQIS+V	140	18	65	17	20	180	115	230	280	25	10,5	280	60	-
200	042127	FLV200AQIS+V	175	22	75	17	25	220	135	270	300	25	12,5	300	70	-
250	042128	FLV250AQIS+V	220	26	90	21	25	270	165	330	390	31	14,5	330	80	-
320	040683	FLV320AQIS+V	270	33	110	25	30	340	200	400	475	37	15	370	90	-

Main features

32 ÷ 320 **ISO** PB..AQIS+V
 Bores Ø **MS1** Type

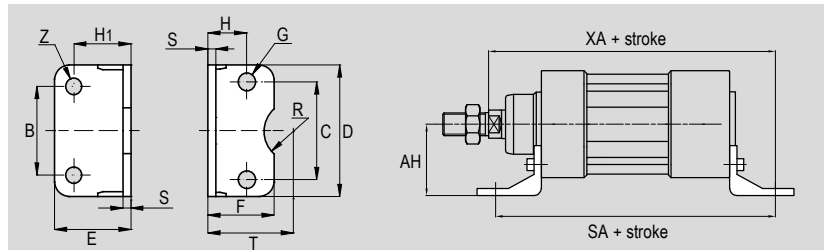

Technical data

Type	Description	Material	Treatment
PB..AQIS+V	Mounting for cylinders in steel. Low foot. For front or rear mounting. Supplied with screws. Supplied individually.	Fe 37	White zinc plating

Dimensions

For cylinder Ø mm	Code	Item	C	B	D	E	F	G	H	H ₁	S	T	R	Z	AH	XA	SA	Weight (g)
32	042129	PB032AQIS+V	32,5	32	45	35	30	7	15,75	24	4	32	15	7	32	144	142	-
40	042130	PB040AQIS+V	38	36	52	36	30	7	17	28	4	36	17,5	10	36	163	161	-
50	042131	PB050AQIS+V	46,5	45	65	47	36	9	21,75	32	5	45	20	10	45	175	170	-
63	042132	PB063AQIS+V	56,5	50	75	45	35	9	21,75	32	5	50	22,5	10	50	190	185	-
80	042133	PB080AQIS+V	72	63	95	55	47	11	27	41	6	63	22,5	12	63	215	210	-
100	042134	PB100AQIS+V	89	75	115	57	53	11	26,5	41	6	71	27,5	14,5	71	230	220	-
125	042135	PB125AQIS+V	110	90	140	65	55	12,5	35	45	8	90	30	16	-	270	250	-
160	042136	PB160AQIS+V	140	115	180	80	75	16,5	45	60	8	115	32,5	18	-	320	300	-
200	042137	PB200AQIS+V	175	135	220	100	90	16,5	47,5	70	9	135	37,5	22	-	345	320	-
250	042138	PB250AQIS+V	220	165	270	110	110	21	55	75	20	165	45	28	-	380	350	-
320	042139	PB320AQIS+V	270	200	350	125	100	24,5	50	85	23	185	50	35	-	425	390	-

Mounting accessories for cylinders

Mountings in steel for cylinders ISO 15552



Main features

32 ÷ 320



SEC..AQIS+SG

Bores Ø

AA4

Type

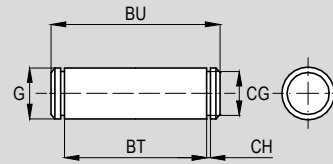

Technical data

Type	Description	Material
SEC..AQIS	Mounting for cylinders in steel. Pin. For rear female clevis ISO MP2. Supplied with two seeger.	Steel AVP

Dimensions

For cylinder Ø mm	Code	Item	G	BT	CG	CH	BU	Weight (g)
32	040261	SEC032AQIS+SG	10	46	9,6	1,1	53	32
40	040262	SEC040AQIS+SG	12	53	11,5	1,1	60	52
50	040263	SEC050AQIS+SG	12	61	11,5	1,1	68	60
63	040264	SEC063AQIS+SG	16	71	15,2	1,1	78	122
80	040265	SEC080AQIS+SG	16	91	15,2	1,1	98	152
100	040266	SEC100AQIS+SG	20	111	19	1,3	118	290
125	040267	SEC125AQIS+SG	25	132	23,9	1,3	139	530
160	040268	SEC160AQIS+SG	30	171,5	28,6	1,6	178	978
200	040269	SEC200AQIS+SG	30	171,5	28,6	1,6	178	978
250	040270	SEC250AQIS+SG	40	202	37,5	1,85	211	2100
320	040460	SEC320AQIS+SG	45	222	42,5	1,85	236	2950

Main features

32 ÷ 250



SEC..ARAQIS+SG

Bores Ø

AA6

Type

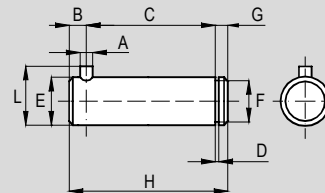

Technical data

Type	Description	Material
SEC..ARAQIS	Mounting for cylinders in steel. Anti-rotating pin. For narrow rear female clevis ISO AB6 (for bearing DIN 648K). Supplied with one seeger.	Steel AVP

Dimensions

For cylinder Ø mm	Code	Item	A	C	D	E	F	G	H	L	B	Weight (g)	
32	040571	SEC032ARAQIS+SG	3	32,5	1,1	10	9,6	4	41	14	4,5	0 -1	26
40	040572	SEC040ARAQIS+SG	4	38	1,1	12	11,5	4	48	16	6		42
50	040573	SEC050ARAQIS+SG	4	43	1,1	16	15,2	5	54	20	6		84
63	040574	SEC063ARAQIS+SG	4	49	1,1	16	15,2	5	60	20	6		94
80	040575	SEC080ARAQIS+SG	4	63	1,3	20	19	6	75	24	6		184
100	040576	SEC100ARAQIS+SG	4	73	1,3	20	19	6	85	24	6	208	
125	040577	SEC125ARAQIS+SG	6	94	1,6	30	28,6	7	110	36	9	606	
160	040578	SEC160ARAQIS+SG	6	119	1,6	35	33	7	135	41	9	972	
200	040579	SEC200ARAQIS+SG	6	119	1,6	35	33	7	135	41	9	972	
250	040600	SEC250ARAQIS+SG	8	121	1,85	40	37,5	7	140	48	12	1365	

Mounting accessories for cylinders

Mountings in steel for cylinders ISO 15552



1 - CYLINDERS

Main features

32 ÷ 200 CT..AQIS+GR
Bores Ø MT4 Type

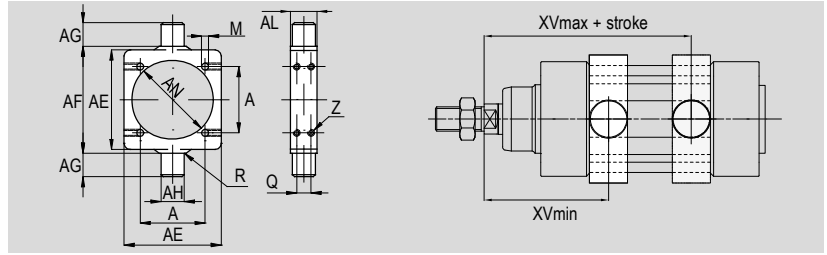

Technical data

Type	Description	Material	Treatment
CT..AQIS+GR	Mounting for cylinders in steel. Adjustable center trunnion (tie-rods). Supplied with grains. Compatible with cylinders type AMT and BMT. For trunnion mounted on the cylinder, please order together with the cylinder. Support type ST..AQIS to be ordered separately, see page 1.98.8	Steel A105	White zinc plating

Dimensions

For cylinder Ø mm	Code	Item	A	AE	AL	AH e9	AG h14	AF h14	AN	R	M	Q	Z	XVmin	XVmax	Weight (g)
32	040581	CT032AQIS+GR	32,5	46	15	12	12	50	37	1	6,25	7	M5	60	86	110
40	040582	CT040AQIS+GR	38	59	20	16	16	63	46	1,5	6,25	8	M5	69	96	290
50	040583	CT050AQIS+GR	46,5	69	20	16	16	75	56	1,6	8,25	8	M6	78	102	330
63	040584	CT063AQIS+GR	56,5	84	25	20	20	90	69	1,6	8,25	12	M6	82	113	650
80	040585	CT080AQIS+GR	72	102	25	20	20	110	87	1,6	10,25	12	M8	97	123	830
100	040586	CT100AQIS+GR	89	125	30	25	25	132	107	2	10,25	15	M8	107	133	1560
125	040587	CT125AQIS+GR	110	155	32	25	25	160	133	2	12,25	15	M10	126,5	163,5	2450
160	040588	CT160AQIS+GR	140	190	40	32	32	200	170	2,5	16,25	18	M12	150	190	4150
200	040589	CT200AQIS+GR	175	240	40	32	32	250	211	2,5	16,25	18	M12	165	205	7300

Main features

32 ÷ 125 CTS..AQIS+GR
Bores Ø MT4 Type

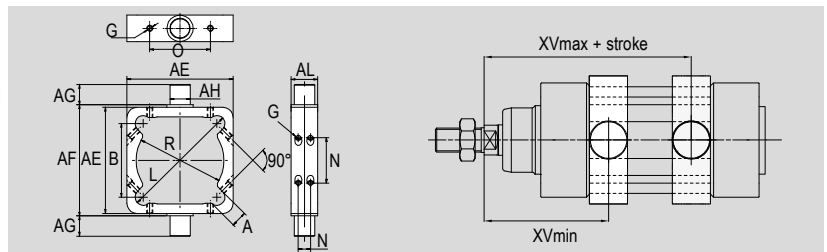

Technical data

Type	Description	Material	Treatment
CTS..AQIS+GR	Mounting for cylinders in steel. Center trunnion (profile barrel). Supplied with grains. Compatible with cylinders type AMA and BMA. For trunnion mounted on the cylinder, please order together with the cylinder. Support type ST..AQIS to be ordered separately, see page 1.98.8	Steel A105	White zinc plating

Dimensions

For cylinder Ø mm	Code	Item	B	AE	AL	AH e9	AG h14	AF h14	R	L	G	A	M	N	O	XVmin	XVmax	Weight (g)
32	040601	CTS032AQIS+GR	33	48.5	18	12	12	50	37	57	M5	11	15.5	7	-	60	86	104
40	040602	CTS040AQIS+GR	38	59	20	16	16	63	46	64	M6	11	20	8	-	69	96	234
50	040603	CTS050AQIS+GR	48	71	20	16	16	75	56	82	M6	14	22.5	8	-	78	102	300
63	040604	CTS063AQIS+GR	58	84	26	20	20	90	69	96	M6	14	30	12	-	82	113	577
80	040605	CTS080AQIS+GR	73	105	26	20	20	110	87	119	M6	16	45	12	58	97	123	858
100	040606	CTS100AQIS+GR	91	129	32	25	25	132	107	144.5	M8	17	60	15	74	107	133	1565
125	040607	CTS125AQIS+GR	116	154	33	25	25	160	133	181	M8	18	85.5	15	104	126,5	163,5	1932

Mounting accessories for cylinders

Mountings in steel for cylinders ISO 15552



Main features

32 ÷ 320  CTN..AQIS
Bores Ø MT4 Type

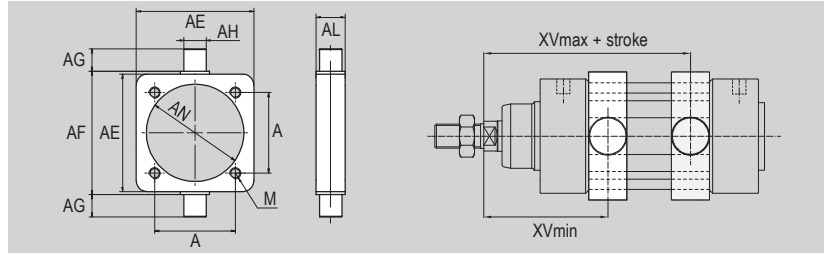

Technical data

Type	Description	Material	Treatment
CTN..AQIS	Mounting for cylinders in steel. Non adjustable center trunnion (threaded). Compatible with cylinders type AMT and BMT. For trunnion mounted on the cylinder, please order together with the cylinder, indicating the XV dimension (cannot be modified). Support type ST..AQIS to be ordered separately, see page 1.98.8	Steel A105	White zinc plating

Dimensions

For cylinder Ø mm	Code	Item	A	AE	AL	AH e9	AG h14	AF h14	AN	M	XVmin	XVmax	Weight (g)
32	040052	CTN032AQIS	32.5	46	15	12	12	50	37	M6	60	86	128
40	040053	CTN040AQIS	38	59	20	16	16	63	46	M6	69	96	308
50	048590	CTN050AQIS	46.5	69	20	16	16	75	56	M8	78	102	370
63	040564	CTN063AQIS	56.5	84	25	20	20	90	69	M8	82	113	690
80	040096	CTN080AQIS	72	102	25	20	20	110	87	M10	97	123	894
100	040097	CTN100AQIS	89	125	30	25	25	132	107	M10	107	133	1584
125	040098	CTN125AQIS	110	155	32	25	25	160	133,5	M12	126,5	163,5	2600
160	040099	CTN160AQIS	140	190	40	32	32	200	171	M16	150	190	4300
200	040100	CTN200AQIS	175	240	40	32	32	250	211	M16	165	205	7450
250	040110	CTN250AQIS	220	296	50	40	40	320	268	M20	185	225	13000
320	040590	CTN320AQIS	270	370	60	50	50	400	343	M24	207	253	22500

Main features

32 ÷ 200  CTA..AQIS+V
Bores Ø MT5/MT6 Type

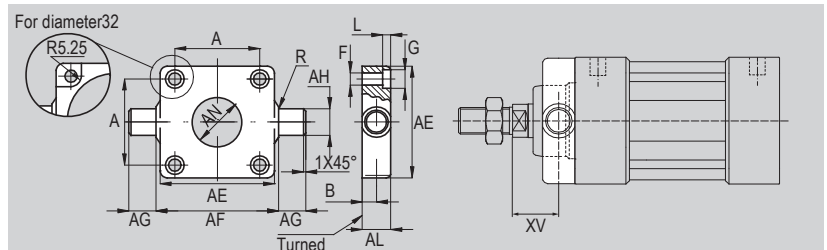

Technical data

Type	Description	Material	Treatment
CTA..AQIS+V	Mounting for cylinders in steel. Center trunnion for heads. For front or rear mounting. Supplied with screws. Compatible with cylinders type AMA, AMT, BMA and BMT. Support type ST..AQIS to be ordered separately, see page 1.98.8	Steel A105	White zinc plating

Dimensions

For cylinder Ø mm	Code	Item	AE	AL	AH e9	AG h14	AF h14	AN	A	B	F	G	L	R	XV	Weight (g)
32	040591	CTA032AQIS+V	46	14	12	12	50	30	32,5	6,5	6,5	-	6	1	19	137
40	040592	CTA040AQIS+V	59	19	16	16	63	35	38	9	6,5	10,5	6	1,6	20,5	385
50	040593	CTA050AQIS+V	69	19	16	16	75	40	46,5	9	8,5	13,5	8	1,6	27,5	513
63	040594	CTA063AQIS+V	84	24	20	20	90	45	56,5	11,5	8,5	13,5	8	1,6	25	1041
80	040595	CTA080AQIS+V	102	24	20	20	110	45	72	11,5	10,5	16,5	10	1,6	34	1567
100	040596	CTA100AQIS+V	125	29	25	25	132	55	89	14	10,5	16,5	10	2	36,5	2400
125	040598	CTA125AQIS+V	155	32	25	25	160	60	110	-	13,5	20	12	2	49	3000
160	040631	CTA160AQIS+V	190	40	32	32	200	65	140	-	17	25	16	2,5	60	4150
200	040632	CTA200AQIS+V	240	40	32	32	250	75	175	-	17	25	16	2,5	75	7350

Mounting accessories for cylinders

Mountings in steel for cylinders ISO 15552



Main features

32 ÷ 320  ST..AQIS
Bores Ø AT4 Type

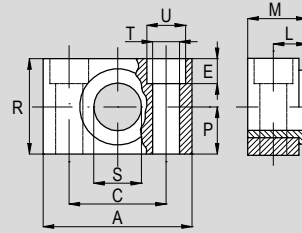

Technical data

Type	Description	Material	Treatment
ST..AQIS	Mounting for cylinders in steel. Support for center trunnion. Supplied individually.	Fe 37 - Bronze	Black cataphoresis

Dimensions

For cylinder Ø mm	Code	Item	A	M	R	P	C	S	L	U	T	E	Weight (g)
32	040681	ST032AQIS	46	18	30	15	32	12	10,5	11	6,6	7	100
40	040682	ST040/050AQIS	55	21	36	18	36	16	12	15	9	9	150
50													
63	040684	ST063/080AQIS	65	23	40	20	42	20	13	18	11	11	234
80													
100	040686	ST100/125AQIS	75	28,5	50	25	50	25	16	20	14	13	435
125													
160	040688	ST160/200AQIS	92	40	60	30	60	32	22,5	26	18	17	850
200													
250	040689	ST250AQIS	140	56	70	35	90	40	31	33	22	20	2750
320	040690	ST320AQIS	150	60	80	40	100	50	32,5	39	26	25,5	3520

Mounting accessories for cylinders

Mountings in aluminium for cylinders CNOMO



Main features

32 ÷ 200 **CNOMO** CF..ALCN
Bores Ø Type

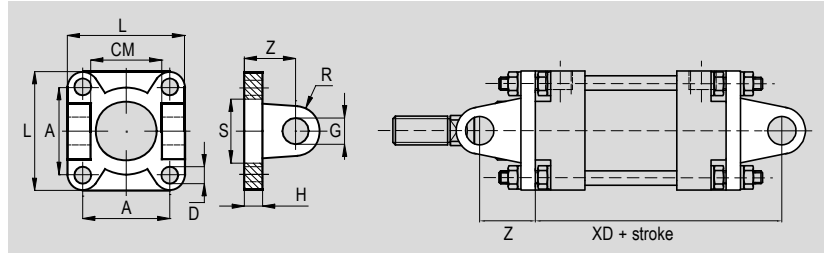

Technical data

Type	Description	Material	Treatment
CF..ALCN	Mounting for cylinders in aluminium. Rear clevis. For front or rear mounting. Pin type SEC..AQCN to be ordered separately, see page 1.99.51. Nuts and growers to be ordered separately, see page 1.101.20.	Die-cast aluminium	Sifting

Dimensions

For cylinder Ø mm	Code	Item	A	L	D	H	CM	S	R	Z	G	XD	Weight (g)
32	040401	CF032ALCN	33	45	7	8	26	25	8	18	8	98	38
40	040402	CF040ALCN	40	52	7	8	33	32	12	24	12	134	58
50	040403	CF050ALCN	49	65	9	10	33	32	12	26	12	138	118
63	040404	CF063ALCN	59	75	9	10	47	45	16	30	16	155	146
80	040405	CF080ALCN	75	95	11	12	47	45	16	32	16	157	324
100	040406	CF100ALCN	90	115	11	12	57	55	20	37	20	182	492
125	040407	CF125ALCN	110	140	14	16	57	55	21	41	20	186	978
160	040408	CF160ALCN	140	180	18	20	72	65	25	55	25	235	1872
200	040409	CF200ALCN	175	220	18	20	72	65	25	55	25	235	2800

Main features

32 ÷ 200 **CNOMO** AN..ALCN
Bores Ø Type

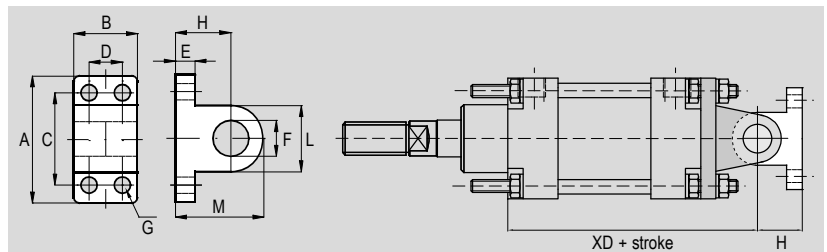

Technical data

Type	Description	Material	Treatment
AN..ALCN	Mounting for cylinders in aluminium. Rear standard hinge. For mounting with rear female clevis.	Die-cast aluminium	Sifting

Dimensions

For cylinder Ø mm	Code	Item	A	B	C	D	E	F	G	H	L	M	XD	Weight (g)
32	040281	AN032ALCN	40	25	28	-	8	8	7	18	16	26	98	26
40	040282	AN040/050ALCN	52	32	38	16	10	12	9	26	24	38	134	56
50													138	
63	040284	AN063/080ALCN	75	46	54	25	12	16	11	34	36	52	155	176
80													157	
100	040286	AN100/125ALCN	115	56	90	32	16	20	14	41	40	61	182	376
125													186	
160	040288	AN160/200ALCN	180	71	150	43	20	25	18	55	50	80	235	924
200														

Mounting accessories for cylinders

Mountings in aluminium for cylinders CNOMO



1 - CYLINDERS

Main features

32 ÷ 200 **CNOMO** AS..ALCN

Bores Ø

Type

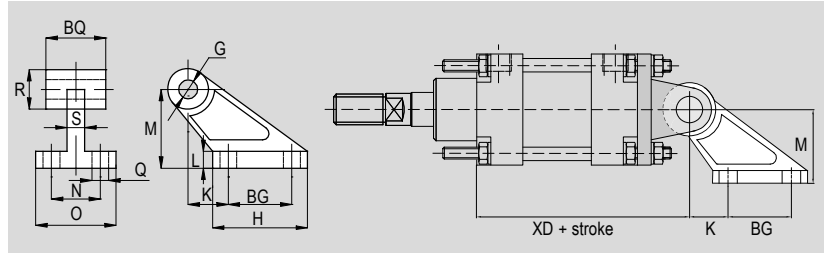

Technical data

Type	Description	Material	Treatment
AS..ALCN	Mounting for cylinders in aluminium. Rear 90° hinge. For mounting with rear female clevis. Nuts and growers to be ordered separately, see page 1.101.20.	Die-cast aluminium	Sifting

Dimensions

For cylinder Ø mm	Code	Item	Q	BG	H	K	L	M	N	O	S	R	BQ	G	XD	Weight (g)
32	040321	AS032ALCN	7	20	37	18	8	32	25	41	9	19,5	25	8	98	58
40	040322	AS040/050ALCN	9	32	54	25	10	45	32	52	14	26	32	12	134	144
50															138	
63	040324	AS063/080ALCN	11	50	75	32	13	63	40	63	14	32	46	16	155	300
80															157	
100	040326	AS100/125ALCN	14	70	103	40	17	90	50	80	22	42	56	20	182	694
125															186	
160	040328	AS160/200ALCN	18	110	154	50	20	140	63	111	26	54	70	25	235	1922
200																

Main features

25 ÷ 200 **CNOMO** P..ALCN

Bores Ø

Type

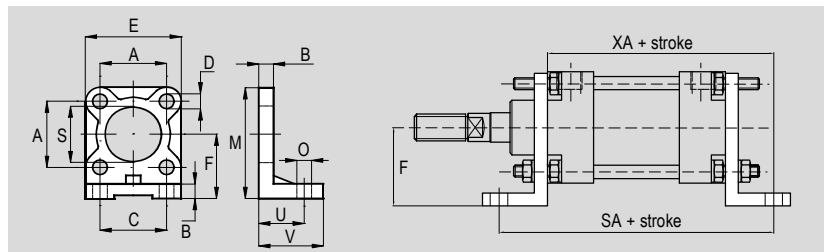

Technical data

Type	Description	Material	Treatment
P..ALCN	Mounting for cylinders in aluminium. High foot. For front or rear mounting. Supplied individually. Nuts and growers to be ordered separately, see page 1.101.20.	Die-cast aluminium	Sifting

Dimensions

For cylinder Ø mm	Code	Item	A	B	C	D	E	F	M	O	S	U	V	XA	SA	Weight (g)
25	040198	P025ALCN	28	8	24	7	40	30	50	9	25	27	35	107	134	40
32	040101	P032ALCN	33	8	28	7	45	32	54	9	25	27	35	107	134	54
40	040102	P040ALCN	40	8	36	7	52	36	62	9	32	27	35	137	164	70
50	040103	P050ALCN	49	10	45	9	65	45	77	11	32	35	45	145	180	150
63	040104	P063ALCN	59	10	55	9	75	50	87	11	45	35	45	160	195	170
80	040105	P080ALCN	75	12	70	11	95	63	110	14	45	43	55	168	211	354
100	040106	P100ALCN	90	12	90	11	115	73	130	14	55	43	55	188	231	470
125	040107	P125ALCN	110	16	110	14	140	91	161	18	55	52	68	197	249	918
160	040108	P160ALCN	140	20	130	18	180	115	205	22	65	62	82	242	304	2300
200	040109	P200ALCN	175	20	170	18	220	135	245	22	65	62	92	242	304	3450

Mounting accessories for cylinders

Mountings in steel for cylinders CNOMO



Main features

32 ÷ 200 **CNOMO** FL..AQCN
Bores Ø Type

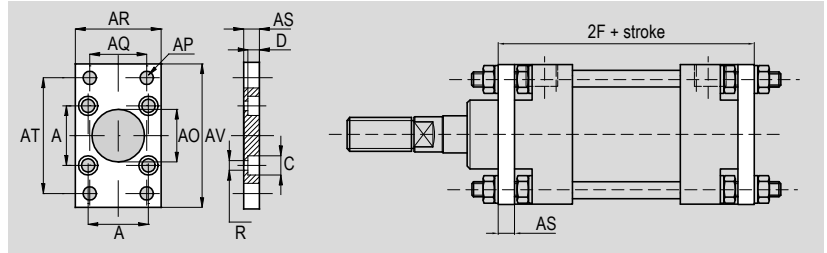

Technical data

Type	Description	Material	Treatment
FL..AQCN	Mounting for cylinders in steel. Counterbored flange. For front or rear mounting. Nuts and growers to be ordered separately, see page 1.101.20.	Fe 37	White zinc plating

Dimensions

For cylinder Ø mm	Code	Item	A	AP	AO	R	AS	AR	AQ	AT	AV	C	D	2F	Weight (g)
32	040621	FL032AQCN	33	9	25	6,5	8	45	33	69	80	10,5	6	96	158
40	040622	FL040AQCN	40	9	32	6,5	8	52	40	78	90	10,5	6	126	206
50	040623	FL050AQCN	49	11	32	9	10	65	49	94	110	13,5	8	130	424
63	040624	FL063AQCN	59	11	45	9	10	75	59	104	120	13,5	8	145	504
80	040625	FL080AQCN	75	14	45	10,5	12	95	75	130	150	16,5	10	149	1046
100	040626	FL100AQCN	90	14	55	10,5	12	115	90	150	170	16,5	10	169	1480
125	040627	FL125AQCN	110	18	55	13,5	16	140	110	180	205	19	12,5	175	3000
160	040628	FL160AQCN	140	22	65	16,5	20	180	140	228	260	24,5	16,5	220	6300
200	040629	FL200AQCN	175	22	65	16,5	20	220	175	268	300	24,5	16,5	220	9300

Main features

32 ÷ 200 **CNOMO** FLF..AQCN
Bores Ø Type

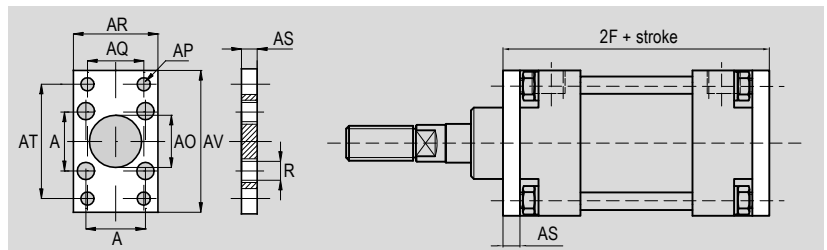

Technical data

Type	Description	Material	Treatment
FLF..AQCN	Mounting for cylinders in steel. Threaded flange. For front or rear mounting. Nuts and growers to be ordered separately, see page 1.101.20. With mounting this accessory, quote T of tie-rods (see page 1.14.21 or 1.14.41) will be 1 mm lower of the flange thickness (AS dimension), while on the opposite side, quote T is equal 0. The accessory necessarily has to be ordered with the cylinder.	Fe 37	White zinc plating

Dimensions

For cylinder Ø mm	Code	Item	A	AP	AO	R	AS	AR	AQ	AT	AV	2F	Weight (g)
32	040948	FLF032AQCN	33	9	25	M6	8	45	33	69	80	96	170
40	040949	FLF040AQCN	40	9	32	M6	8	52	40	78	90	126	220
50	040950	FLF050AQCN	49	11	32	M8	10	65	49	94	110	130	450
63	040951	FLF063AQCN	59	11	45	M8	10	75	59	104	120	145	532
80	040952	FLF080AQCN	75	14	45	M10	12	95	75	130	150	149	1100
100	040953	FLF100AQCN	90	14	55	M10	12	115	90	150	170	169	1536
125	040954	FLF125AQCN	110	18	55	M12	16	140	110	180	205	175	3100
160	040955	FLF160AQCN	140	22	65	M16	20	180	140	228	260	220	6500
200	040956	FLF200AQCN	175	22	65	M16	20	220	175	268	300	220	9500

Mounting accessories for cylinders

Mountings in steel for cylinders CNOMO



1 - CYLINDERS

Main features

32 ÷ 200 **CNOMO** PB..AQC�

Bores Ø

Type

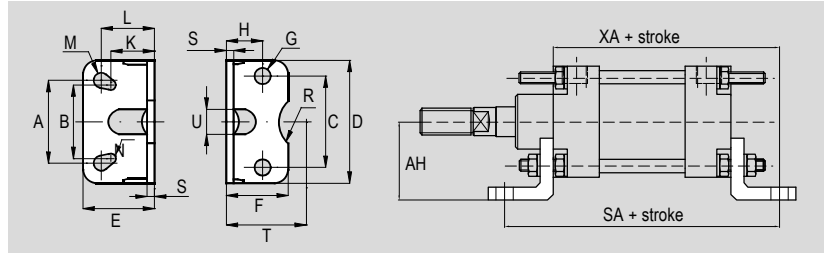

Technical data

Type	Description	Material	Treatment
PB..AQC�	Mounting for cylinders in steel. Low foot. For front or rear mounting. Supplied individually. Nuts and growers to be ordered separately, see page 1.101.20.	Fe 37	White zinc plating

Dimensions

For cylinder Ø mm	Code	Item	A	B	C	D	E	F	G	H	K	L	M	N	R	S	T	U	AH _{J13}	XA	SA	Weight (g)
32	040161	PB032AQC�	28	32	33	45	35	30	7	15,5	22	27	4,5	3,5	12,5	4	32	11	29,5	107	134	66
40	040162	PB040AQC�	36	36	40	52	36	30	7	16	26	27	4,5	4,5	16	4	36	15	32,5	137	164	78
50	040163	PB050AQC�	45	45	49	65	45	36	9	20,5	30	35	5,5	4,5	16	5	45	16	40,5	145	180	168
63	040164	PB063AQC�	55	50	59	75	45	35	9	20,5	30	35	5,5	4,5	22,5	5	50	18	45	160	195	190
80	040165	PB080AQC�	70	63	75	95	55	45	11	25,5	37	43	7	5,5	22,5	6	63	17	63	168	211	382
100	040166	PB100AQC�	90	75	90	115	56	44	11	27	37,5	43	7	6,5	27,5	6	73	24	72	188	231	452
125	040167	PB125AQC�	100	-	110	140	70	70	14	36	-	52	9	-	27,5	8	91	-	91	197	249	1150
160	040168	PB160AQC�	130	-	140	180	75	100	18	45	-	62	11	-	32,5	9	115	-	115	242	304	2000
200	040169	PB200AQC�	170	-	175	220	100	100	18	47	-	62	11	-	32,5	12	135	-	134,5	242	304	3800

Main features

32 ÷ 200 **CNOMO** SEC..AQC�

Bores Ø

Type

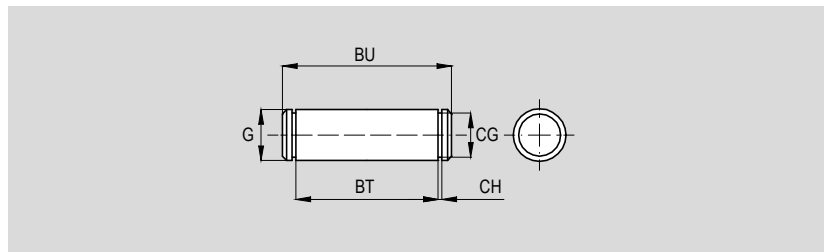

Technical data

Type	Description	Material	Treatment
SEC..AQC�	Mounting for cylinders in steel. Pin for female rear clevis. Supplied with two seeger.	AVP steel	White zinc plating

Dimensions

For cylinder Ø mm	Code	Item	G	BT	CG	CH	BU	Weight (g)
32	040221	SEC032AQC�	8	46	7,6	1,1	53	21
40	040222	SEC040AQC�	12	53	11,5	1,1	60	52
50	040223	SEC050AQC�	12	66	11,5	1,1	73	64
63	040224	SEC063AQC�	16	76	15,2	1,1	83	130
80	040225	SEC080AQC�	16	96	15,2	1,1	103	160
100	040226	SEC100AQC�	20	117	19	1,3	124	304
125	040227	SEC125AQC�	20	142	19	1,3	149	364
160	040228	SEC160AQC�	25	182	23,9	1,3	189	720
200	040229	SEC200AQC�	25	222	23,9	1,3	229	872

Mounting accessories for cylinders

Mountings in steel for cylinders CNOMO



Main features

32 ÷ 200 **CNOMO** CT..AQCN

Bores Ø

Type

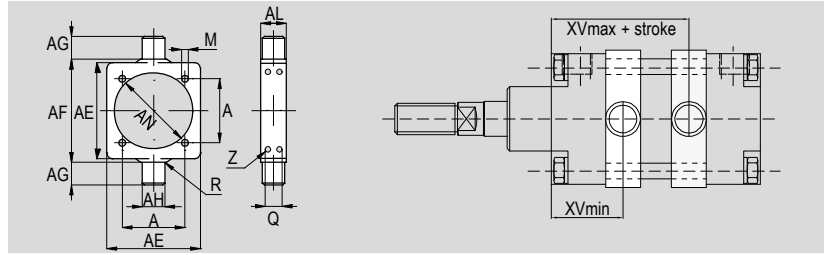

Technical data

Type	Description	Material	Treatment
CT..AQCN	Mounting for cylinders in steel. Adjustable center trunnion (tie-rods). Supplied with grains. With mounting this accessory, quote T of tie-rods (see page 1.14.21 o 1.14.41) is equal 0 in every bore. For trunnion mounted on the cylinder, please order together with the cylinder. Support type ST..AQIS to be ordered separately, see page 1.99.53	A105 steel	White zinc plating

Dimensions

For cylinder Ø mm	Code	Item	A	AE	AL	AH	AG	AF	AN	R	M	Q	Z	XV min.	XV max.	Weight (g)
32	040559	CT032AQCN	33	46	15	12	12	50	37	1	6,25	7	M5	32,5	47,5	110
40	040558	CT040AQCN	40	59	20	16	16	63	46	1,5	6,25	8	M5	41	69	290
50	040538	CT050AQCN	49	69	20	16	16	73	56	1,6	8,25	8	M6	45	65	330
63	040540	CT063AQCN	59	84	25	20	20	90	69	1,6	8,25	12	M6	52,5	72,5	650
80	040545R	CT080AQCN	75	102	25	20	20	108	87	1,6	10,25	12	M8	52,5	72,5	830
100	040546R	CT100AQCN	90	125	30	25	25	131	107	2	10,25	15	M8	57	88	1560
125	040580	CT125AQCN	110	155	32	25	25	160	133,5	2	12,25	15	M10	58	87	2450
160	040630	CT160AQCN	140	190	40	32	32	200	171	2,5	16,25	18	M12	67	113	4150
200	040597	CT200AQCN	175	240	40	32	32	250	211	2,5	16,25	18	M12	68	112	7300

Main features

32 ÷ 200 **CNOMO** CTN..AQCN

Bores Ø

Type

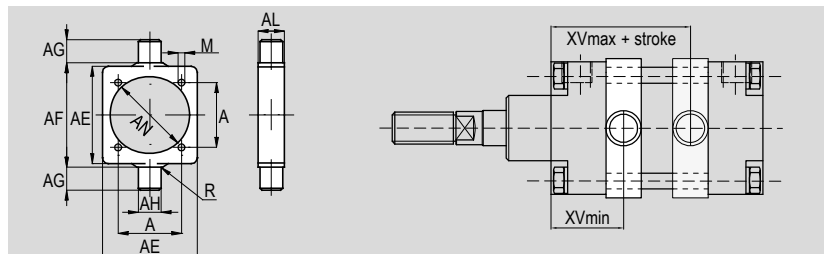

Technical data

Type	Description	Material	Treatment
CTN..AQCN	Mounting for cylinders in steel. Non adjustable center trunnion (threaded). With mounting this accessory, quote T of tie-rods (see page 1.14.21 o 1.14.41) is equal 0 in every bore. For trunnion mounted on the cylinder, please order together with the cylinder, indicating the XV dimension (cannot be modified). Support type ST..AQIS to be ordered separately, see page 1.99.53	A105 steel	White zinc plating

Dimensions

For cylinder Ø mm	Code	Item	A	AE	AL	AH	AG	AF	AN	R	M	XV min.	XV max.	Weight (g)
32	040541	CTN032AQCN	33	46	15	12	12	50	37	1	M6	32,5	47,5	130
40	040542	CTN040AQCN	40	59	20	16	16	63	46	1,5	M6	41	69	306
50	040543	CTN050AQCN	49	69	20	16	16	73	56	1,6	M8	45	65	370
63	040544	CTN063AQCN	59	84	25	20	20	90	69	1,6	M8	52,5	72,5	702
80	040545	CTN080AQCN	75	102	25	20	20	108	87	1,6	M10	52,5	72,5	894
100	040546	CTN100AQCN	90	125	30	25	25	131	107	2	M10	57	88	1590
125	040547	CTN125AQCN	110	155	32	25	25	160	133,5	2	M12	58	87	2600
160	040548	CTN160AQCN	140	190	40	32	32	200	171	2,5	M16	67	113	4300
200	040549	CTN200AQCN	175	240	40	32	32	250	211	2,5	M16	68	112	7450

Mounting accessories for cylinders

Mountings in steel for cylinders CNOMO



Main features

32 ÷ 200



ST..AQIS

Bores Ø

AT4

Type

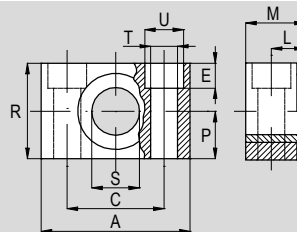

Technical data

Type	Description	Material	Treatment
ST..AQIS	Mounting for cylinders in steel. Support for center trunnion. Supplied individually.	Fe 37 - Bronze	Black cataphoresis

Dimensions

For cylinder Ø mm	Code	Item	A	M	R	P	C	S	L	U	T	E	Weight (g)
32	040681	ST032AQIS	46	18	30	15	32	12	10,5	11	6,6	7	100
40	040682	ST040/050AQIS	55	21	36	18	36	16	12	15	9	9	150
50													
63	040684	ST063/080AQIS	65	23	40	20	42	20	13	18	11	11	234
80													
100	040686	ST100/125AQIS	75	28,5	50	25	50	25	16	20	14	13	435
125													
160	040688	ST160/200AQIS	92	40	60	30	60	32	22,5	26	18	17	850
200													

Mounting accessories for cylinders

Mountings in aluminium for compact cylinders ISO 21287



Main features

32 ÷ 125 CF..ALIS+VP
Bores Ø MP2 Type

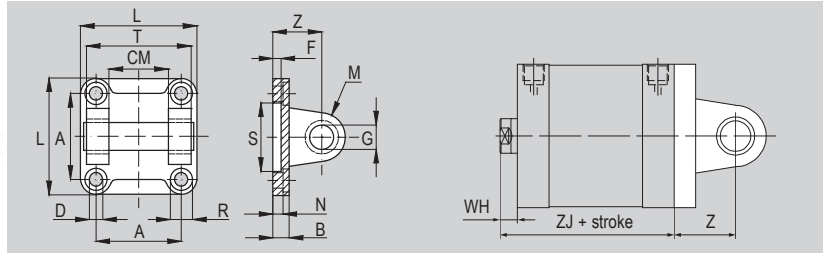

Technical data

Type	Description	Material	Treatment
CF..ALIS+VP	Mounting for cylinders in aluminium. Rear clevis. Supplied with screws and pin.	Die-cast aluminium	Sifting

Dimensions

For cylinder Ø mm	Code	Item	A	L	D	R	N	B	S	F	Z	G	M	CM	T	ZJ	WH	Weight (g)
32	042050	CF032ALIS+VP	32,5	45	6,6	11	5,5	9	30	5	22	10	10	26	45	51	7	-
40	042051	CF040ALIS+VP	38	52	6,6	11	5,5	9	35	5	25	12	12	28	52	52	7	-
50	042052	CF050ALIS+VP	46,5	65	9	15	6,5	11	40	5	27	12	12	32	60	53	8	-
63	042053	CF063ALIS+VP	56,5	75	9	15	6,5	11	45	5	32	16	16	40	70	57	8	-
80	042054	CF080ALIS+VP	72	95	11	18	10	14	45	5	36	16	16	50	90	64	10	-
100	042055	CF100ALIS+VP	89	115	11	18	10	14	55	5	41	20	20	60	110	77	10	-
125	042056	CF125ALIS+VP	110	140	14	20	10	20	60	7	50	25	25	70	130	92	11	-

Main features

32 ÷ 125 CF..ALIS+V
Bores Ø MP2 Type

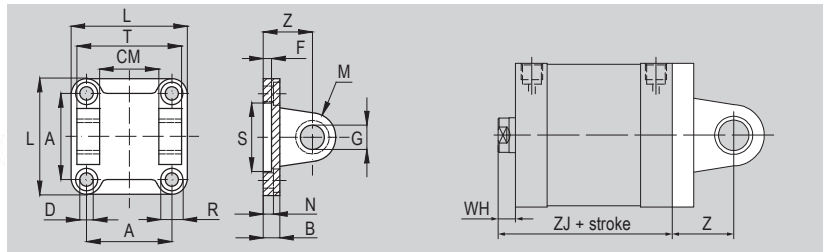

Technical data

Type	Description	Material	Treatment
CF..ALIS+V	Mounting for cylinders in aluminium. Rear clevis. Supplied with screws.	Die-cast aluminium	Sifting

Dimensions

For cylinder Ø mm	Code	Item	A	L	D	R	N	B	S	F	Z	G	M	CM	T	ZJ	WH	Weight (g)
32	040441	CF032ALIS+V	32,5	45	6,6	11	5,5	9	30	5	22	10	10	26	45	51	7	-
40	040442	CF040ALIS+V	38	52	6,6	11	5,5	9	35	5	25	12	12	28	52	52	7	-
50	040443	CF050ALIS+V	46,5	65	9	15	6,5	11	40	5	27	12	12	32	60	53	8	-
63	040444	CF063ALIS+V	56,5	75	9	15	6,5	11	45	5	32	16	16	40	70	57	8	-
80	040445	CF080ALIS+V	72	95	11	17	10	14	45	5	36	16	16	50	90	64	10	-
100	040446	CF100ALIS+V	89	115	11	18	10	14	55	5	41	20	20	60	110	77	10	-
125	040447	CF125ALIS+V	110	140	14	20	10	20	60	7	50	25	25	70	130	92	11	-

Mounting accessories for cylinders

Mountings in aluminium for compact cylinders ISO 21287



1 - CYLINDERS

Main features

32 ÷ 125 **ISO** CFS..ALIS+VP
Bores Ø AB6 Type

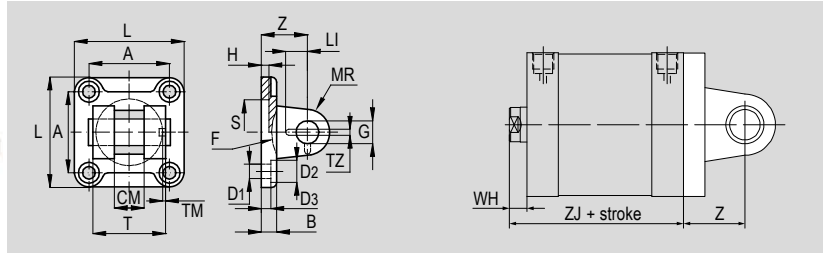

Technical data

Type	Description	Material	Treatment
CFS..ALIS+VP	Mounting for cylinders in aluminium. Narrow rear clevis. Supplied with screws and anti-rotating pin.	Die-cast aluminium	Sifting

Dimensions

For cylinder Ø mm	Code	Item	L	T	CM	A	Z	H	B	D ₃	S	G	MR	D ₁	D ₂	TM	TZ	LI	F	ZJ	WH	Weight (g)
32	042110	CFS032ALIS+VP	45	34	14	32,5	22	5	9	5,5	30	10	10	6,6	11	3	3,3	11,5	17	51	7	-
40	042111	CFS040ALIS+VP	52	40	16	38	25	5	9	5,5	35	12	12	6,6	11	4	4,3	12	20	52	7	-
50	042112	CFS050ALIS+VP	65	45	21	46,5	27	5	11	6,5	40	16	14	9	15	4	4,3	14	22	53	8	-
63	042113	CFS063ALIS+VP	75	51	21	56,5	32	5	11	6,5	45	16	18	9	15	4	4,3	14	25	57	8	-
80	042114	CFS080ALIS+VP	95	65	25	72	36	5	14	10	45	20	20	11	18	4	4,3	16	30	64	10	-
100	042115	CFS100ALIS+VP	115	75	25	89	41	5	14	10	55	20	22	11	18	4	6,3	16	32	77	10	-
125	042116	CFS125ALIS+VP	140	97	37	110	50	7	20	10	60	30	25	14	20	6	6,3	24	42	92	11	-

Main features

32 ÷ 125 **ISO** CFS..ALIS+V
Bores Ø AB6 Type

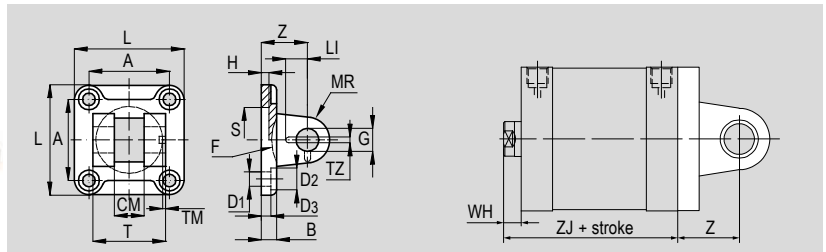

Technical data

Type	Description	Material	Treatment
CFS..ALIS+V	Mounting for cylinders in aluminium. Narrow rear clevis. Supplied with screws.	Die-cast aluminium	Sifting

Dimensions

For cylinder Ø mm	Code	Item	L	T	CM	A	Z	H	B	D ₃	S	G	MR	D ₁	D ₂	TM	TZ	LI	F	ZJ	WH	Weight (g)
32	040451	CFS032ALIS+V	45	34	14	32,5	22	5	9	5,5	30	10	10	6,6	11	3	3,3	11,5	17	51	7	-
40	040452	CFS040ALIS+V	52	40	16	38	25	5	9	5,5	35	12	12	6,6	11	4	4,3	12	20	52	7	-
50	040453	CFS050ALIS+V	65	45	21	46,5	27	5	11	6,5	40	16	14	9	15	4	4,3	14	22	53	8	-
63	040454	CFS063ALIS+V	75	51	21	56,5	32	5	11	6,5	45	16	18	9	15	4	4,3	14	25	57	8	-
80	040455	CFS080ALIS+V	95	65	25	72	36	5	14	10	45	20	20	11	18	4	4,3	16	30	64	10	-
100	040456	CFS100ALIS+V	115	75	25	89	41	5	14	10	55	20	22	11	18	4	6,3	16	32	77	10	-
125	040457	CFS125ALIS+V	140	97	37	110	50	7	20	10	60	30	25	14	20	6	6,3	24	42	92	11	-

Mounting accessories for cylinders

Mountings in aluminium for compact cylinders ISO 21287



Main features

16 ÷ 25



CM..ALUN

Bores Ø

Type

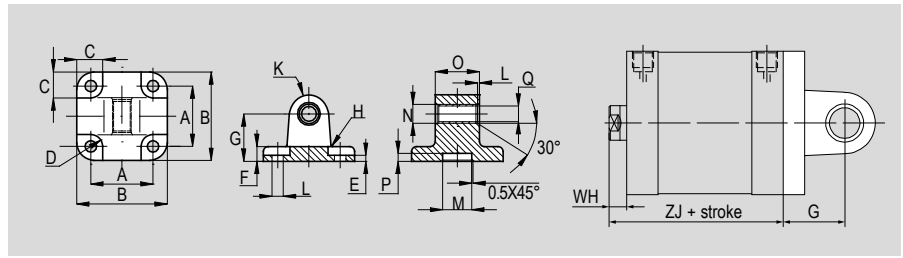

Technical data

Type	Description	Material	Treatment
CM..ALUN	Mounting for cylinders in aluminium. Rear eye. Mounting screws to be ordered separately, see page 1.101.30.	Die-cast aluminium	Sifting

Dimensions

For cylinder Ø mm	Code	Item	A	B	C	D	E	F	G	H	K	L	M	N	O	P	Q	V	ZJ	WH	Weight (g)
16	040701	CM012/016ALUN	18	27	10	4,5	2,6	6	16	2	6	4,5	10	8	12	3	6	10	39,5	4,5	17
20	040702	CM020ALUN	22	34	11	5	2,6	6	20	2	8	5,5	12	10	16	3	8	14	43	6	21
25	040703	CM025ALUN	26	38	11	5	2,6	6	20	2	8	5,5	12	10	16	3	8	14	45	6	27

Main features

32 ÷ 125



CM..ALIS+V

Bores Ø

MP4

Type

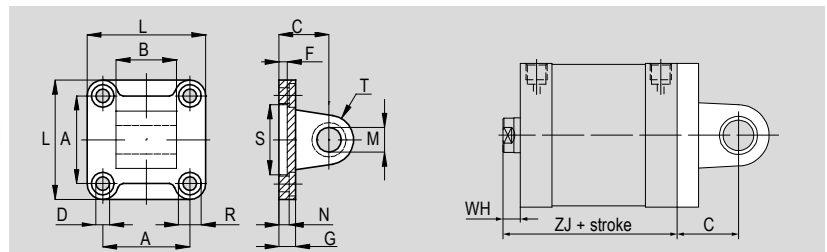

Technical data

Type	Description	Material	Treatment
CM..ALIS+V	Mounting for cylinders in aluminium. Rear eye. Supplied with screws.	Die-cast aluminium	Sifting

Dimensions

For cylinder Ø mm	Code	Item	A	L	D	R	N	G	S	F	C	M	T	B	ZJ	WH	Weight (g)	
32	042061	CM032ALIS+V	32,5	45	6,6	11	5,5	9	30	5	22	10	10	26	-0,2 -0,6	51	7	-
40	042062	CM040ALIS+V	38	52	6,6	11	5,5	9	35	5	25	12	12	28		52	7	-
50	042063	CM050ALIS+V	46,5	65	9	15	6,5	11	40	5	27	12	12	32	-0,5 -1,2	53	8	-
63	042064	CM063ALIS+V	56,5	75	9	15	6,5	11	45	5	32	16	16	40		57	8	-
80	042065	CM080ALIS+V	72	95	11	18	10	14	45	5	36	16	16	50		64	10	-
100	042066	CM100ALIS+V	89	115	11	18	10	14	55	5	41	20	20	60	77	10	-	
125	042067	CM125ALIS+V	110	140	14	20	10	20	60	7	50	25	25	70	92	11	-	

Mounting accessories for cylinders

Mountings in aluminium for compact cylinders ISO 21287



1 - CYLINDERS

Main features

32 ÷ 125 **ISO** CMS..ALIS+V
 Bores Ø MP6 Type

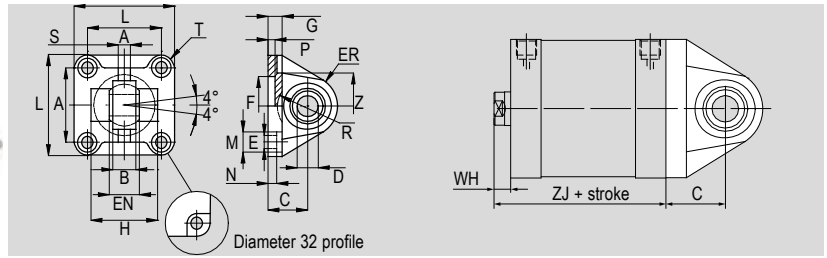

Technical data

Type	Description	Material	Treatment
CMS..ALIS+V	Mounting for cylinders in aluminium. Narrow rear eye with spherical bearing DIN 648K. Supplied with screws.	Die-cast aluminium	Sifting

Dimensions

For cylinder Ø mm	Code	Item	A	B	C	D	EN	ER	F	G	E	L	M	N	P	H	R	S	Z	T	ZJ	WH	Weight (g)
32	042101	CMS032ALIS+V	32,5	10,5	22	10	14	16	30	9	6,6	45	11	5,5	5	-	-	4	32,5	6,25	51	7	42
40	042102	CMS040ALIS+V	38	12	25	12	16	19	35	9	6,6	52	11	5,5	5	-	-	6	39	7	52	7	70
50	042103	CMS050ALIS+V	46,5	15	27	16	21	21	40	11	9	65	15	6,5	5	51	18	8	47	9,25	53	8	112
63	042104	CMS063ALIS+V	56,5	15	32	16	21	24	45	11	9	75	15	6,5	5	-	-	8	52	9,25	57	8	194
80	042105	CMS080ALIS+V	72	18	36	20	25	28,5	45	14	11	95	18	10	5	72	24	10	67	11,5	64	10	382
100	042106	CMS100ALIS+V	89	18	41	20	25	30	55	14	11	115	18	10	5	-	-	10	77	13	77	10	610
125	042107	CMS125ALIS+V	110	25	50	30	37	40	60	20	13,5	140	20	10	7	-	-	13	98	15	92	11	1100

Main features

32 ÷ 125 **ISO** ASV..ALIS+V
 Bores Ø AB7 Type
 RP 107P

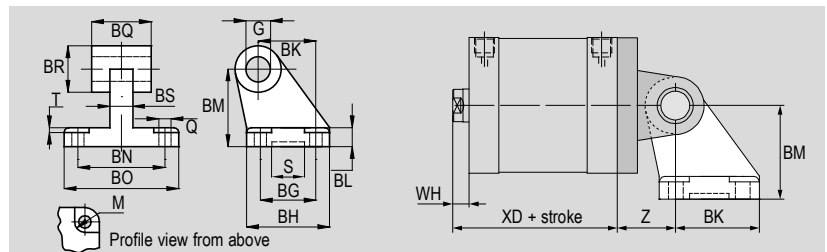

Technical data

Type	Description	Material	Treatment
ASV..ALIS+V	Mounting for cylinders in aluminium. Rear 90° hinge. For mounting with rear female clevis type CF. Supplied with screws.	Die-cast aluminium	Sifting

Dimensions

For cylinder Ø mm	Code	Item	Q	M	BG	BH	BK	BL	BM	BN	BO	BS	BR	G	T	S	BQ	Z	ZJ	WH	Weight (g)	
32	042081	ASV032ALIS+V	6,6	11	18	31	21	8	32	38	51	10	20	10	1,6	10,5	26	-0,2	22	51	7	-
40	042082	ASV040ALIS+V	6,6	11	22	35	24	10	36	41	54	15	22	12	1,6	10,5	28		25	52	7	-
50	042083	ASV050ALIS+V	9	15	30	45	33	12	45	50	65	16	26	12	1,6	10,5	32	-0,6	27	53	8	-
63	042084	ASV063ALIS+V	9	15	35	50	37	14	50	52	67	16	30	16	1,6	10,5	40		32	57	8	-
80	042085	ASV080ALIS+V	11	18	40	60	47	14	63	66	86	20	30	16	2,5	10,5	50	-0,5	36	64	10	-
100	042086	ASV100ALIS+V	11	18	50	70	55	17	71	76	96	20	38	20	2,5	10,5	60		41	77	10	-
125	042087	ASV125ALIS+V	14	20	60	90	70	20	90	94	124	30	45	25	3,2	10,5	70	-1,2	50	92	11	-

Mounting accessories for cylinders

Mountings in aluminium for compact cylinders ISO 21287



Main features

16 ÷ 25



FL..ALUN

Bores Ø

Type

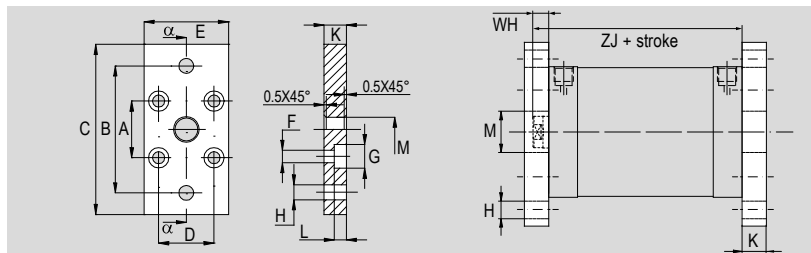

Technical data

Type	Description	Material	Treatment
FL..ALUN	Mounting for cylinders in aluminium. Flange. For front or rear mounting. Mounting screws to be ordered separately, see page 1.101.30.	Die-cast aluminium	Sifting

Dimensions

For cylinder Ø mm	Code	Item	A	B	C	D	E	F	G	H	I	L	M	ZJ	WH	Weight (g)
16	040721	FL012/016ALUN	18	43	55	18	29	4,5	9	5,5	10	5,4	10	39,5	4,5	34
20	040722	FL020ALUN	22	55	70	22	36	5,5	10	6,6	10	5,4	12	43	6	55
25	040723	FL025ALUN	26	60	76	26	40	5,5	10	6,6	10	5,4	12	45	6	68

Main features

32 ÷ 125



FLV..ALIS+V

Bores Ø



Type

MF1/MF2

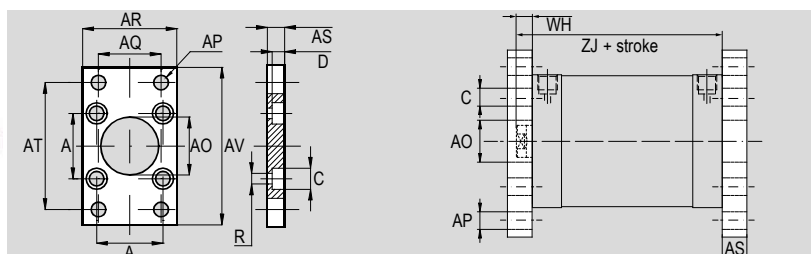

Technical data

Type	Description	Material	Treatment
FLV..ALIS+V	Mounting for cylinders in aluminium. Flange. For front or rear mounting. Supplied with screws.	Die-cast aluminium	Anodized

Dimensions

For cylinder Ø mm	Code	Item	A	ØAP	AO	R	AS	AR	AQ	AT	AV	C	D	ZJ	WH	Weight (g)
32	042150	FLV032ALIS+V	32,5	7	30	6,5	10	45	32	64	86	10,5	5	51	7	-
40	042151	FLV040ALIS+V	38	9	35	6,5	10	52	36	72	96	11	5	52	7	-
50	042152	FLV050ALIS+V	46,5	9	40	9	12	65	45	90	115	15	5,5	53	8	-
63	042153	FLV063ALIS+V	56,5	9	45	9	12	75	50	100	130	15	5,5	57	8	-
80	042154	FLV080ALIS+V	72	12	45	11	16	95	63	126	165	18	7	64	10	-
100	042155	FLV100ALIS+V	89	14	55	11	16	115	75	150	187	18	7	77	10	-
125	042156	FLV125ALIS+V	110	16	60	13	20	140	90	180	224	19	9,5	92	11	-

Mounting accessories for cylinders

Mountings in aluminium for compact cylinders ISO 21287



Main features

32 ÷ 125 **ISO** AS..ALIS
Bores Ø 6431 Type

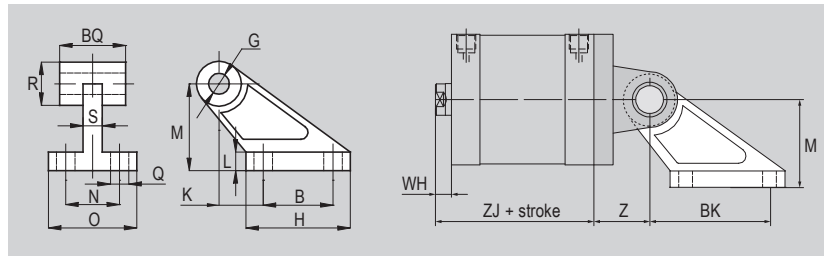

Technical data

Type	Description	Material	Treatment
AS..ALIS	Mountings for cylinders in aluminium. Rear 90° hinge. For mounting with rear female clevis type CF. Mounting screws to be ordered separately, see from page 1.101.1	Die-cast aluminium	Sifting

Dimensions

For cylinder Ø mm	Code	Item	Q	BG	H	I	L	M	N	O	S	R	BQ	G	Z	ZJ	WH	BK	Weight (g)
32	040361	AS032ALIS	7	20	37	18	8	32	25	41	9	19	26	10	22	51	7	38	54
40	040362	AS040ALIS	9	32	54	25	10	45	32	52	14	25,5	28	12	25	52	7	57	136
50	040363	AS050ALIS	9	32	54	25	10	45	32	52	14	25,5	32	12	27	53	8	57	140
63	040364	AS063ALIS	11	50	75	32	12	63	40	63	14	32	40	16	32	57	8	82	295
80	040365	AS080ALIS	11	50	75	32	12	63	40	63	14	32	50	16	36	64	10	82	313
100	040366	AS100ALIS	14	70	103	40	17	90	50	80	22	42	60	20	41	77	10	110	710
125	040367	AS125ALIS	14	70	103	40	17	90	50	80	22	46	70	25	50	92	11	110	820

Main features

32 ÷ 125 **ISO** P..ALIS
Bores Ø MS3 Type

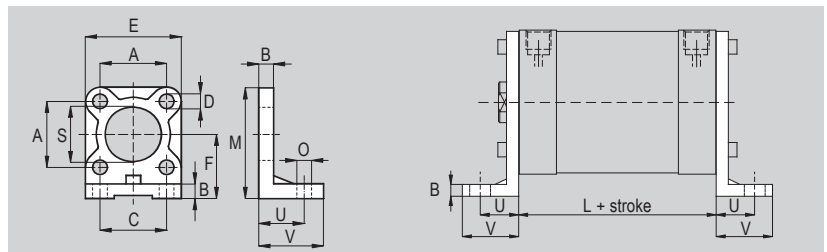

Technical data

Type	Description	Material	Treatment
P..ALIS	Mounting for cylinders in aluminium. Foot. For front or rear mounting. Supplied individually. Mounting screws to be ordered separately, see from page 1.101.1.	Die-cast aluminium	Sifting

Dimensions

For cylinder Ø mm	Code	Item	A	B	C	D	E	F	M	O	S	U	V	AH	XA	SA	Weight (g)
32	040141	P032ALIS	32,5	8	32	7	40	32	54,5	7	30	24	35	31,5	154	138	46
40	040142	P040ALIS	38	8	36	7	52	36	62	9	35	28	35	34	173	161	66
50	040143	P050ALIS	46,5	10	45	9	65	45	77,5	9	40	32	45	42,5	187	170	138
63	040144	P063ALIS	56,5	10	50	9	75	50	87,5	9	45	32	45	47,5	202	185	174
80	040145	P080ALIS	72	12	63	11	95	63	110,5	12	45	41	55	59,5	231	210	356
100	040146	P100ALIS	89	12	75	11	115	71	128	14	55	41	56	69,5	246	220	468
125	040147	P125ALIS	110	16	90	14	140	91	161	16	60	45	68	86	290	250	920

Mounting accessories for cylinders

Mountings in steel for compact cylinders ISO 21287



Main features

32 ÷ 125 **ISO** CF..AQIS+V

Bores Ø MP2 Type

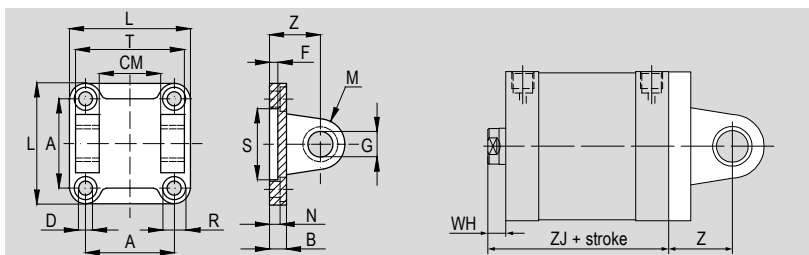

Technical data

Type	Description	Material	Treatment
CF..AQIS+V	Mounting for cylinders in steel. Rear clevis. Supplied with screws. Pin type SEC..AQIS to be ordered separately, see page 1.100.56	A105 steel	Black cataphoresis

Dimensions

For cylinder Ø mm	Code	Item	A	L	D	R	N	B	S	F	Z	G	M	CM	T	ZJ	WH	Weight (g)
32	040461	CF032AQIS+V	32,5	45	6,6	11	5,5	10	30	5	22	10	10	26	45	51	7	164
40	040462	CF040AQIS+V	38	55	6,6	11	5,5	10	35	5	25	12	12	28	52	52	7	256
50	040463	CF050AQIS+V	46,5	65	9	15	6,5	10	40	5	27	12	12	32	60	53	8	392
63	040464	CF063AQIS+V	56,5	75	9	15	6,5	12	45	5	32	16	16	40	70	57	8	594
80	040465	CF080AQIS+V	72	95	11	18	10	14	45	-	36	16	16	50	90	64	10	1102
100	040466	CF100AQIS+V	89	115	11	18	10	16	55	-	41	20	20	60	110	77	10	1802
125	040467	CF125AQIS+V	110	140	14	20	10	20	60	-	50	25	25	70	130	92	11	3493

Main features

32 ÷ 125 **ISO** CFS..AQIS+V

Bores Ø AB6 Type

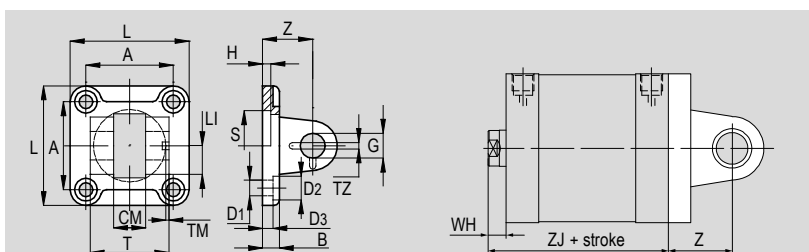

Technical data

Type	Description	Material	Treatment
CFS..AQIS+V	Mounting for cylinders in steel. Narrow rear clevis. Supplied with screws. Anti-rotation pin type SEC..ARAQIS to be ordered separately, see page 1.100.56	A105 steel	Black cataphoresis

Dimensions

For cylinder Ø mm	Code	Item	L	T	CM	A	Z	H	B	D ₃	S	G	D ₁	D ₂	TM	TZ	LI	ZJ	WH	Weight (g)
32	040491	CFS032AQIS+V	45	34	14	32,5	22	5	10	5,5	30	10	6,6	11	3	3,3	11,5	51	7	166
40	040492	CFS040AQIS+V	55	40	16	38	25	5	10	5,5	35	12	6,6	11	4	4,3	12	52	7	256
50	040493	CFS050AQIS+V	65	45	21	46,5	27	5	10	6,5	40	16	9	15	4	4,3	14	53	8	390
63	040494	CFS063AQIS+V	75	51	21	56,5	32	5	12	6,5	45	16	9	15	4	4,3	14	57	8	600
80	040495	CFS080AQIS+V	95	65	25	72	36	5	14	10	45	20	11	18	4	4,3	16	64	10	1292
100	040496	CFS100AQIS+V	115	75	25	89	41	5	16	10	55	20	11	18	4	6,3	16	77	10	1942
125	040497	CFS125AQIS+V	140	97	37	110	50	7	20	10	60	30	14	20	6	6,3	24	92	11	3693

Mounting accessories for cylinders

Mountings in steel for compact cylinders ISO 21287



1 - CYLINDERS

Main features

20 ÷ 25



CM..AQUN

Bores Ø

Type

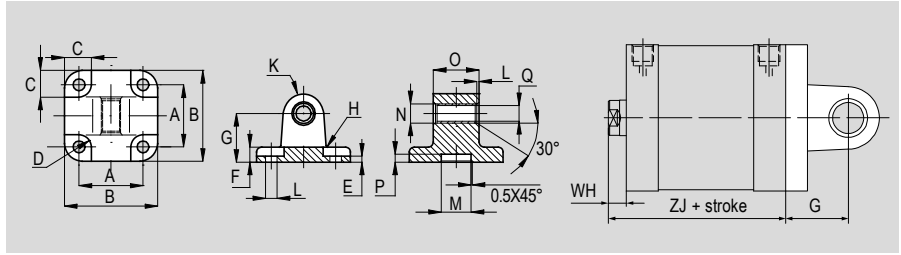

Technical data

Type	Description	Material	Treatment
CM..AQUN	Mounting for cylinders in steel. Rear eye. Screws to be ordered separately, see page 1.101.30	A105 steel	Black cataphoresis

Dimensions

For cylinder Ø mm	Code	Item	A	B	C	D	E	F	G	H	K	L	M	N	O	P	Q	V	ZJ	WH	Weight (g)
20	040732	CM020AQUN	22	34	11	5	2,6	6	20	2	8	5,5	12	10	16	3	8	14	43	6	64
25	040733	CM025AQUN	26	38	11	5	2,6	6	20	2	8	5,5	12	10	16	3	8	14	45	6	80

Main features

32 ÷ 125



CM..AQIS+V

Bores Ø

MP4

Type

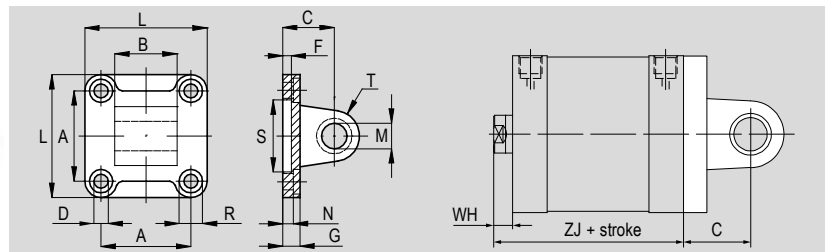

Technical data

Type	Description	Material	Treatment
CM..AQIS+V	Mounting for cylinders in steel. Rear eye. Supplied with screws.	A105 steel	Black cataphoresis

Dimensions

For cylinder Ø mm	Code	Item	A	L	D	R	N	G	S	F	C	M	T	B	ZJ	WH	Weight (g)	
32	040521	CM032AQIS+V	32,5	45	6,6	11	5,5	10	30	5	22	10	10	26	-0,2 -0,6	51	7	202
40	040522	CM040AQIS+V	38	55	6,6	11	5,5	10	35	5	25	12	12	28		52	7	300
50	040523	CM050AQIS+V	46,5	65	9	15	6,5	10	40	5	27	12	12	32		53	8	422
63	040524	CM063AQIS+V	56,5	75	9	15	6,5	12	45	5	32	16	16	40		57	8	736
80	040525	CM080AQIS+V	72	95	11	18	10	14	45	5	36	16	16	50		64	10	1298
100	040526	CM100AQIS+V	89	115	11	18	10	16	55	5	41	20	20	60	77	10	2202	
125	040527	CM125AQIS+V	110	140	14	20	10	20	60	7	50	25	25	70	-0,5 -1,2	92	11	3883

Mounting accessories for cylinders

Mountings in steel for compact cylinders ISO 21287



Main features

32 ÷ 125 **ISO** CMS..AQIS+V

Bores Ø MP6 Type

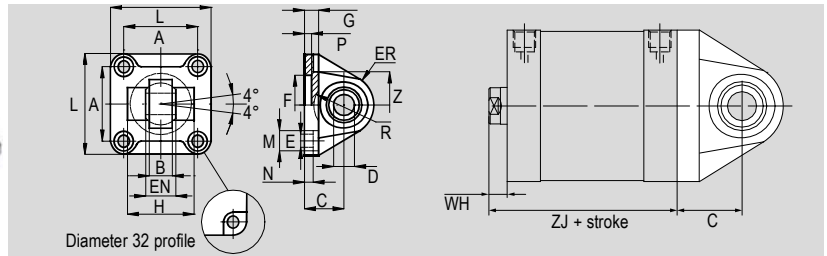

Technical data

Type	Description	Material	Treatment
CMS..AQIS+V	Mounting for cylinders in steel. Narrow rear eye with spherical bearing DIN 648K. Supplied with screws.	A 105 steel	Black cataphoresis

Dimensions

For cylinder Ø mm	Code	Item	A	B	C	D	EN	ER	F	G	E	L	M	N	P	H	R	Z	ZJ	WH	Weight (g)
32	040531	CMS032AQIS+V	32,5	10,5	22	10	14	15	30	10	6,6	45	11	5,5	5	-	-	32,5	51	7	178
40	040532	CMS040AQIS+V	38	12	25	12	16	18	35	10	6,6	55	11	5,5	5	-	-	39	52	7	282
50	040533	CMS050AQIS+V	46,5	15	27	16	21	20	40	10	9	65	15	6,5	5	51	19	47	53	8	418
63	040534	CMS063AQIS+V	56,5	15	32	16	21	23	45	12	9	75	15	6,5	5	-	-	52	57	8	645
80	040535	CMS080AQIS+V	72	18	36	20	25	27	45	14	11	95	18	10	5	70	24	67	64	10	1224
100	040536	CMS100AQIS+V	89	18	41	20	25	30	55	16	11	115	18	10	5	-	-	77	77	10	1888
125	040537	CMS125AQIS+V	110	25	50	30	37	40	60	20	13,5	140	20	10	7	-	-	98	92	11	3643

Main features

32 ÷ 125 **ISO** ASS..AQIS

Bores Ø CS7 Type

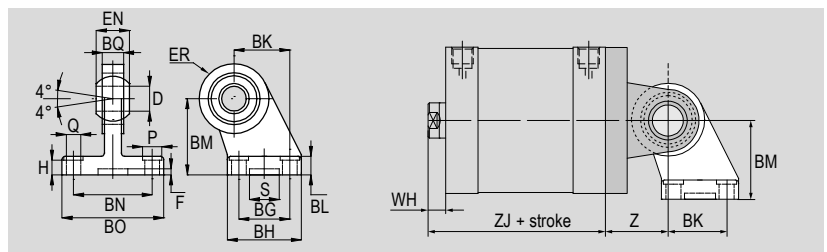

Technical data

Type	Description	Material	Treatment
ASS..AQIS	Mounting for cylinders in steel. Rear 90° hinge with spherical bearing DIN 648K. For mounting with narrow rear female clevis. Mounting screws to be ordered separately, see page 1.101.30.	A 105 steel	Black cataphoresis

Dimensions

For cylinder Ø mm	Code	Item	Q	P	BG	BH	BI	BL	BM	BN	BD	EN	ER	BQ	D	H	S	F	Z	ZJ	WH	Weight (g)
32	040551	ASS032AQIS	6,6	11	18	31	21	10	32	38	51	14	15	10,5	10	8,5	20	3	22	51	7	178
40	040552	ASS040AQIS	6,6	11	22	35	24	10	36	41	54	16	18	12	12	8,5	20	3	25	52	7	268
50	040553	ASS050AQS	9	15	30	45	33	12	45	50	65	21	20	15	16	10,5	20	3	27	53	8	458
63	040554	ASS063AQIS	9	15	35	50	37	12	50	52	67	21	23	15	16	10,5	20	3	32	57	8	550
80	040555	ASS080AQIS	11	18	40	60	47	14	63	66	86	25	27	18	20	11,5	20	3	36	64	10	970
100	040556	ASS100AQIS	11	18	50	70	55	15	71	76	96	25	30	18	20	12,5	20	3	41	77	10	1326
125	040557	ASS125AQIS	13,5	20	60	90	70	20	90	94	124	37	40	25	30	17	20	3	50	92	11	3000

Mounting accessories for cylinders

Mountings in steel for compact cylinders ISO 21287



1 - CYLINDERS

Main features

16 ÷ 25



CF

Bores Ø

MP3

Type

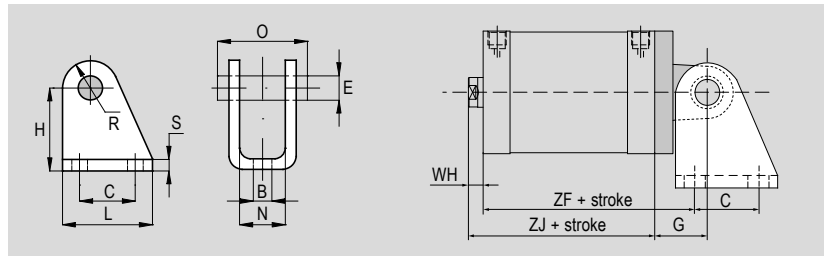

Technical data

Type	Description	Material	Treatment
CF..	Mounting for cylinders in steel. Rear 90° hinge. For mounting with male rear eye type CM. Supplied with pin e two seeger.	Steel	White zinc plating

Dimensions

For cylinder Ø mm	Code	Item	B	E	C	H	L	N	O	R	S	ZF	ZJ	WH	G	Weight (g)
16	040049	CF12-16+P	5,5	6	15	27	25	12,1	23	7	3	35	39,5	4,5	16	75
20	040050	CF20-25+P	6,6	8	20	30	32	16,1	29,5	10	4	37	43	6	20	78
25												39	45			

Main features

32 ÷ 125



ASV..AQIS

Bores Ø

AB7

Type



RP 107P

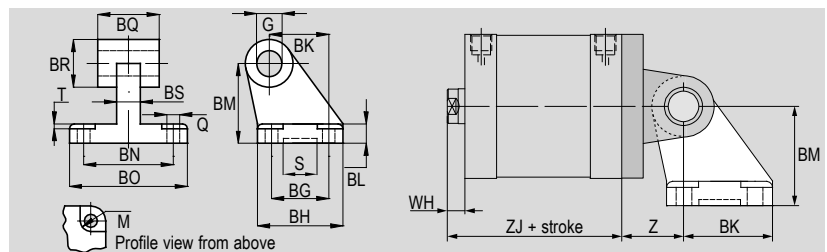

Technical data

Type	Description	Material	Treatment
ASV..AQIS	Mounting for cylinders in steel. Rear 90° hinge. For mounting with female rear clevis type CF. Mounting screws to be ordered separately, see page 1.101.30.	Steel A 105	Black cataphoresis

Dimensions

For cylinder Ø mm	Code	Item	Q	M	BG	BH	BK	BL	BM	BN	BO	BS	BR	G	T	S	BQ	Z	ZJ	WH	Weight (g)
32	040381	ASV032AQIS	6,6	11	18	31	21	8	32	38	51	10	20	10	6,5	20	26	22	51	7	184
40	040382	ASV040AQIS	6,6	11	22	35	24	10	36	41	54	10	22	12	8,5	20	28	25	52	7	264
50	040383	ASV050AQIS	9	15	30	45	33	12	45	50	65	14	26	12	10,5	20	32	27	53	8	472
63	040384	ASV063AQIS	9	15	35	50	37	12	50	52	67	14	30	16	10,5	20	40	32	57	8	580
80	040385	ASV080AQIS	11	18	40	60	47	14	63	66	86	18	30	16	11,5	20	50	36	64	10	1157
100	040386	ASV100AQIS	11	18	50	70	55	15	71	76	96	20	36	20	12,5	20	60	41	77	10	1612
125	040387	ASV125AQIS	14	20	60	90	70	20	90	94	124	30	45	25	17	20	70	50	92	11	3293

Mounting accessories for cylinders

Mountings in steel for compact cylinders ISO 21287



Main features

16 ÷ 25



FL..AQUN

Bores Ø

Type

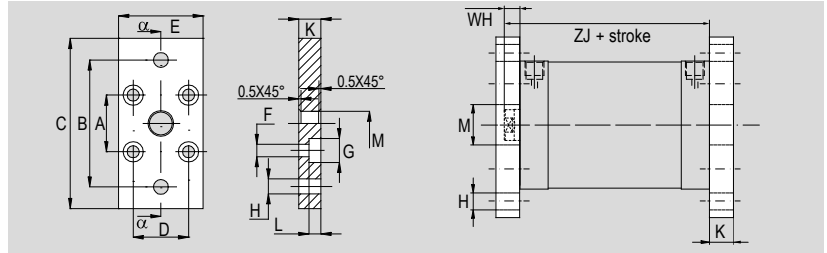

Technical data

Type	Description	Material	Treatment
FL..AQUN	Mounting for cylinders in steel. Flange. For front or rear mounting. Mounting screws to be ordered separately, see page 1.101.30.	Fe 37	White zinc plating

Dimensions

For cylinder Ø mm	Code	Item	A	B	C	D	E	F	G	H	I	L	M	ZJ	WH	Weight (g)
16	040751	FL012016AQUN	18	43	55	18	29	4,5	9	5,5	10	5,4	10	39,5	4,5	34
20	040752	FL020AQUN	22	55	70	22	36	5,5	10	6,6	10	5,4	12	43	6	55
25	040753	FL025AQUN	26	60	76	26	40	5,5	10	6,6	10	5,4	12	45	6	68

Main features

32 ÷ 125



FLV..AQIS+V

Bores Ø



Type

MF1/MF2

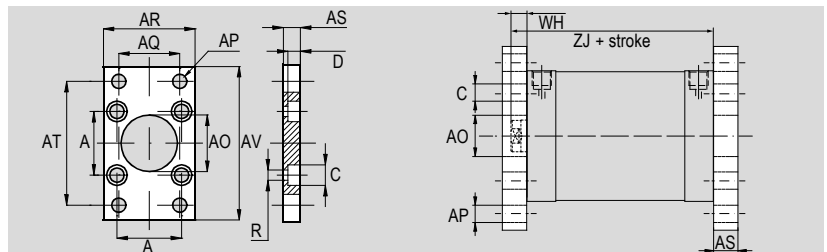

Technical data

Type	Description	Material	Treatment
FLV..AQIS+V	Mounting for cylinders in steel. Flange. For front or rear mounting. Supplied with screws.	Fe 37	White zinc plating

Dimensions

For cylinder Ø mm	Code	Item	A	ØAP	AO	R	AS	AR	AQ	AT	AV	C	D	ZJ	WH	Weight (g)
32	042119	FLV032AQIS+V	32,5	7	30	6,5	10	45	32	64	86	10,5	5	51	7	-
40	042120	FLV040AQIS+V	38	9	35	6,5	10	52	36	72	96	11	5	52	7	-
50	042121	FLV050AQIS+V	46,5	9	40	9	12	65	45	90	115	15	5,5	53	8	-
63	042122	FLV063AQIS+V	56,5	9	45	9	12	75	50	100	130	15	5,5	57	8	-
80	042123	FLV080AQIS+V	72	12	45	11	16	95	63	126	165	18	7	64	10	-
100	042124	FLV100AQIS+V	89	14	55	11	16	115	75	150	187	18	7	77	10	-
125	042125	FLV125AQIS+V	110	16	60	13	20	140	90	180	224	19	9,5	92	11	-

Mounting accessories for cylinders

Mountings in steel for compact cylinders ISO 21287



1 - CYLINDERS

Main features

16 ÷ 25



PB..AQUN

Bores Ø

Type

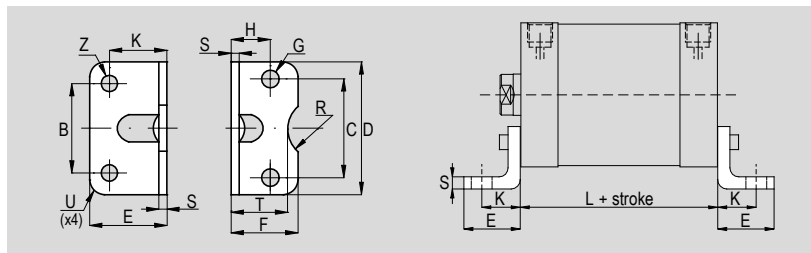

Technical data

Type	Description	Material	Treatment
PB..AQUN	Mounting for cylinders in steel. Low foot. For front or rear mounting. Supplied individually. Mounting screws to be ordered separately, see page 1.101.30.	Fe 37	White zinc plating

Dimensions

For cylinder Ø mm	Code	Item	C	B	D	E	F	G	H	K	S	T	R	U	Z	L	Weight (g)
16	040761	PB012/016AQUN	18	18	30	17,5	17,5	4,4	13	13	3	15	9	2	5,5	35	20
20	040762	PB20AQUN	22	22	36	22	22	5,4	16	16	4	17	10	2	6,6	37	32
25	040763	PB25AQUN	26	26	40	22	23	5,4	17	16	4	19	11	2	6,6	39	38

Main features

32 ÷ 125



PB..AQIS+V

Bores Ø

MS1

Type

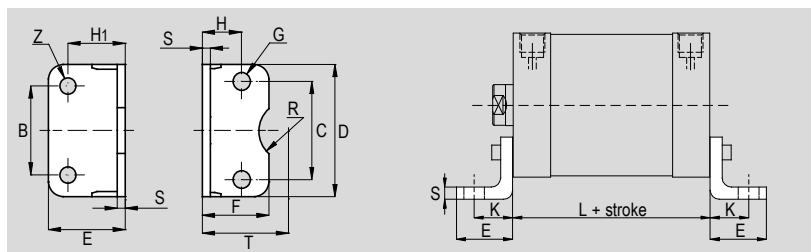

Technical data

Type	Description	Material	Treatment
PB..AQIS+V	Mounting for cylinders in steel. Low foot. For front or rear mounting. Supplied with screws. Supplied individually.	Fe 37	White zinc plating

Dimensions

For cylinder Ø mm	Code	Item	C	B	D	E	F	G	H	H ₁	S	T	R	Z	AH	XA	SA	Weight (g)
32	042129	PB032AQIS+V	32,5	32	45	35	30	7	15,75	24	4	32	15	7	32	144	142	-
40	042130	PB040AQIS+V	38	36	52	36	30	7	17	28	4	36	17,5	10	36	163	161	-
50	042131	PB050AQIS+V	46,5	45	65	47	36	9	21,75	32	5	45	20	10	45	175	170	-
63	042132	PB063AQIS+V	56,5	50	75	45	35	9	21,75	32	5	50	22,5	10	50	190	185	-
80	042133	PB080AQIS+V	72	63	95	55	47	11	27	41	6	63	22,5	12	63	215	210	-
100	042134	PB100AQIS+V	89	75	115	57	53	11	26,5	41	6	71	27,5	14,5	71	230	220	-
125	042135	PB125AQIS+V	110	90	140	65	55	12,5	35	45	8	90	30	16	-	270	250	-

Mounting accessories for cylinders

Mountings in steel for compact cylinders ISO 21287



Main features

32 ÷ 125



SEC..AQIS+SG

Bores Ø

AA4

Type

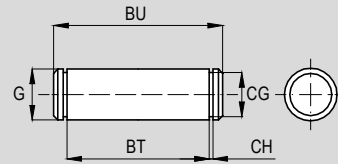

Technical data

Type	Description	Material
SEC..AQIS	Mounting for cylinders in steel. Pin. For rear female clevis ISO MP2. Supplied with two seeger.	Steel AVP

Dimensions

For cylinder Ø mm	Code	Item	G	BT	CG	CH	BU	Weight (g)
32	040261	SEC032AQIS+SG	10	46	9,6	1,1	53	32
40	040262	SEC040AQIS+SG	12	53	11,5	1,1	60	52
50	040263	SEC050AQIS+SG	12	61	11,5	1,1	68	60
63	040264	SEC063AQIS+SG	16	71	15,2	1,1	78	122
80	040265	SEC080AQIS+SG	16	91	15,2	1,1	98	152
100	040266	SEC100AQIS+SG	20	111	19	1,3	118	290
125	040267	SEC125AQIS+SG	25	132	23,9	1,3	139	530

Main features

32 ÷ 125



SEC..ARAQIS+SG

Bores Ø

AA6

Type

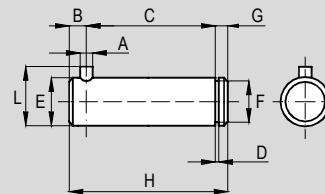

Technical data

Type	Description	Material
SEC..ARAQIS	Mounting for cylinders in steel. Anti-rotating pin. Per narrow rear female clevis ISO AB6 with bearing DIN 648K. Supplied with one seeger.	Steel AVP

Dimensions

For cylinder Ø mm	Code	Item	A	C	D	E	F	G	H	L	B	Weight (g)	
32	040571	SEC032ARAQIS+SG	3	32,5	1,1	10	9,6	4	41	14	4,5	0 -1	26
40	040572	SEC040ARAQIS+SG	4	38	1,1	12	11,5	4	48	16	6		42
50	040573	SEC050ARAQIS+SG	4	43	1,1	16	15,2	5	54	20	6		84
63	040574	SEC063ARAQIS+SG	4	49	1,1	16	15,2	5	60	20	6		94
80	040575	SEC080ARAQIS+SG	4	63	1,3	20	19	6	75	24	6		184
100	040576	SEC100ARAQIS+SG	4	73	1,3	20	19	6	85	24	6		208
125	040577	SEC125ARAQIS+SG	6	94	1,6	30	28,6	7	110	36	9	0 -2	606

Mounting accessories for cylinders

Mountings in steel for compact cylinders ISO 21287



Main features

32 ÷ 125 **ISO** CTA..AQIS+V
Bores Ø MT5/MT6 Type

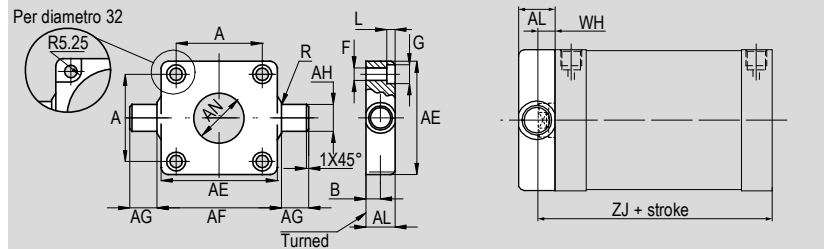

Technical data

Type	Description	Material	Treatment
CTA..AQIS+GR	Mounting for cylinders in steel. Center trunnion for heads. For front or rear mounting. Supplied with screws. Support type ST..AQIS to be ordered separately, see page 1.100.57	Steel A105	White zinc plating

Dimensions

For cylinder Ø mm	Code	Item	AE	AL	AH e9	AG h14	AF h14	AN	A	B	F	G	L	R	ZJ	WH	Weight (g)
32	040591	CTA032AQIS+V	46	14	12	12	50	30	32,5	6,5	6,5	-	6	1	51	7	137
40	040592	CTA040AQIS+V	59	19	16	16	63	35	38	9	6,5	10,5	6	1,6	54,5	7	385
50	040593	CTA050AQIS+V	69	19	16	16	75	40	46,5	9	8,5	13,5	8	1,6	54,5	8	513
63	040594	CTA063AQIS+V	84	24	20	20	90	45	56,5	11,5	8,5	13,5	8	1,6	61	8	1041
80	040595	CTA080AQIS+V	102	24	20	20	110	45	72	11,5	10,5	16,5	10	1,6	66	10	1567
100	040596	CTA100AQIS+V	125	29	25	25	132	55	89	14	10,5	16,5	10	2	81,5	10	3000
125	040598	CTA125AQIS+V	155	32	25	25	160	133	110	-	13,5	20	12	2	97	11	2400

Main features

32 ÷ 125 **ISO** ST..AQIS
Bores Ø AT4 Type

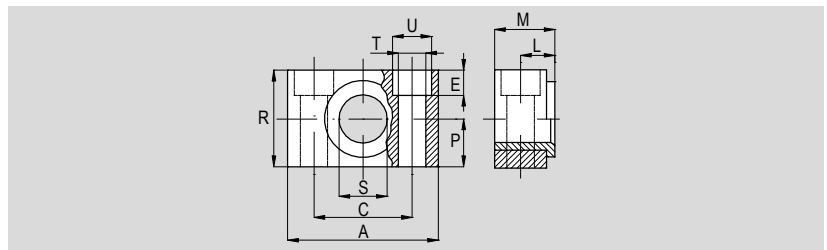

Technical data

Type	Description	Material	Treatment
ST..AQIS	Mounting for cylinders in steel. Support for center trunnion. Supplied individually.	Fe 37 - Bronze	Black cataphoresis

Dimensions

For cylinder Ø mm	Code	Item	A	M	R	P	C	S	L	U	T	E	Weight (g)
32	040681	ST032AQIS	46	18	30	15	32	12	10,5	11	6,6	7	100
40-50	040682	ST040/050AQIS	55	21	36	18	36	16	12	15	9	9	150
63-80	040684	ST063/080AQIS	65	23	40	20	42	20	13	18	11	11	234
100-125	040686	ST100/125AQIS	75	28,5	50	25	50	25	16	20	14	13	435

Mounting accessories for cylinders

Mountings in aluminium for compact cylinders UNITOP



Main features

32 ÷ 100



CF..ALUN



Bores Ø

Type

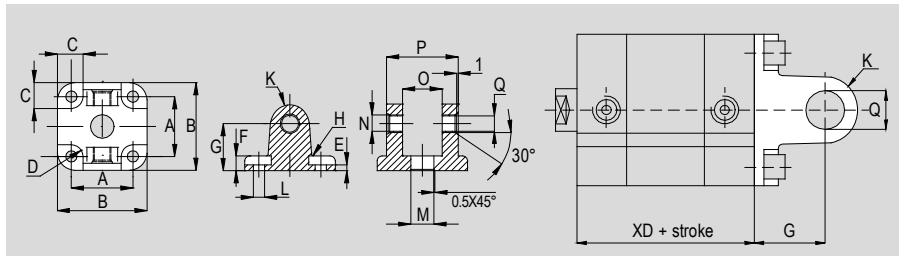

Technical data

Type	Description	Material	Treatment
CF..ALUN	Mounting for cylinders in aluminium. Rear clevis. Pin type SEC..AQIS to be ordered separately, see page 1.98.5. Mounting screws to be ordered separately, see page 1.101.40.	Die-cast aluminium	Sifting

Dimensions

For cylinder Ø mm	Code	Item	A	B	C	D	E	F	G	H	K	L	M	N	O	P	Q	XD	Weight (g)
32	040711	CF032ALUN	32	48	13,5	5,5	5,5	9	22	2,5	10	6,6	14	12	26	45	10	44,5	60
40	040712	CF040ALUN	42	58	13,5	5,5	5,5	9	25	2,5	12,5	6,6	14	14	28	52	12	45,5	104
50	040713	CF050ALUN	50	66	15,5	7,5	6,5	11	27	2,5	12,5	9	18	14	32	60	12	45,5	142
63	040714	CF063ALUN	62	83	18	7,5	6,5	11	32	4	15	9	18	18	40	70	16	50	240
80	040715	CF080ALUN	82	102	19	9	10	13	36	4	15	11	23	18	50	90	16	56	420
100	040716	CF100ALUN	103	123	19	9	10	15	41	4	20	11	28	23	60	110	20	66,5	721

Main features

12 ÷ 25



CM..ALUN



Bores Ø

Type

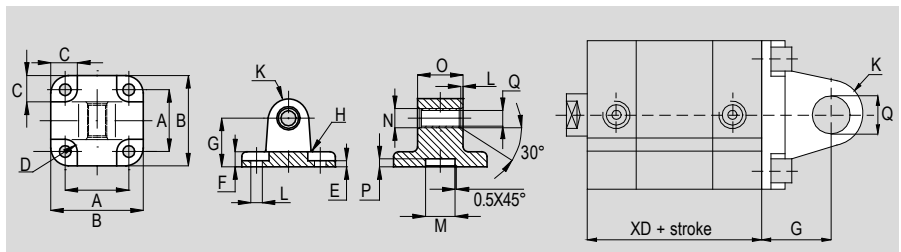

Technical data

Type	Description	Material	Treatment
CM..ALUN	Mounting for cylinders in aluminium. Rear eye. Mounting screws to be ordered separately, see page 1.101.40.	Die-cast aluminium	Sifting

Dimensions

For cylinder Ø mm	Code	Item	A	B	C	D	E	F	G	H	K	L	M	N	O	P	Q	XD	Weight (g)
12	040701	CM012/016ALUN	18	27	10	4,5	2,6	6	16	2	6	4,5	10	8	12	3	6	38	17
16																			
20	040702	CM020ALUN	22	34	11	5	2,6	6	20	2	8	5,5	12	10	16	3	8	38	21
25	040703	CM025ALUN	26	38	11	5	2,6	6	20	2	8	5,5	12	10	16	3	8	39,5	27

Mounting accessories for cylinders

Mountings in aluminium for compact cylinders UNITOP



1 - CYLINDERS

Main features

12 ÷ 25



FL..ALUN

Type

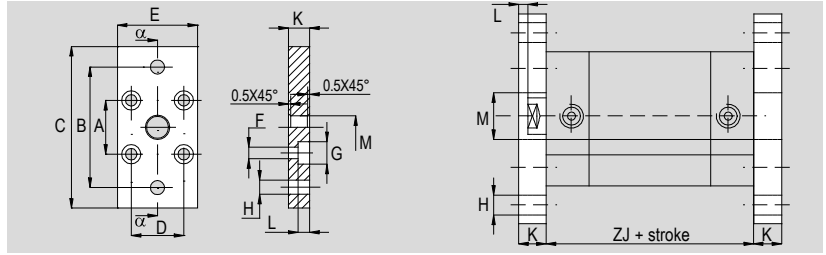

Technical data

Type	Description	Material	Treatment
FL..ALUN	Mounting for cylinders in aluminium. Flange. For front or rear mounting. Mounting screws to be ordered separately, see page 1.101.40.	Die-cast aluminium	Anodized

Dimensions

For cylinder Ø mm	Code	Item	A	B	C	D	E	F	G	H	K	L	M	XD	Weight (g)
12	040721	FL012/016ALUN	18	43	55	18	29	4,5	9	5,5	10	5,4	10	38	34
16															
20	040722	FL020ALUN	22	55	70	22	36	5,5	10	6,6	10	5,4	12	38	55
25	040723	FL025ALUN	26	60	76	26	40	5,5	10	6,6	10	5,4	12	39,5	68

Main features

32 ÷ 100



FL..ALUN

Type

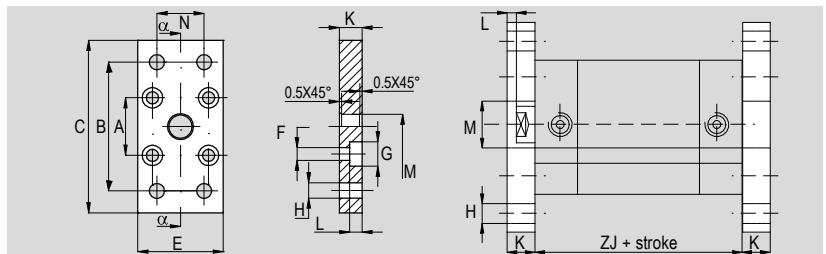

Technical data

Type	Description	Material	Treatment
FL..ALUN	Mounting for cylinders in aluminium. Flange. For front or rear mounting. Mounting screws to be ordered separately, see page 1.101.40.	Die-cast aluminium	Anodized

Dimensions

For cylinder Ø mm	Code	Item	A	B	C	D	E	F	G	H	K	L	M	N	XD	Weight (g)
32	040724	FL032ALUN	32	65	80	32	50	6,6	11	7	10	6,4	14	32	44,5	88
40	040725	FL040ALUN	42	82	102	42	60	6,6	11	9	10	6,4	14	36	45,5	143
50	040726	FL050ALUN	50	90	110	50	68	9	15	9	12	8,6	18	45	45,5	204
63	040727	FL063ALUN	62	110	130	62	87	9	15	9	15	8,6	18	50	50	411
80	040728	FL080ALUN	82	135	160	82	107	11	18	12	15	10,6	23	63	56	616
100	040729	FL100ALUN	103	163	190	103	128	11	18	14	15	10,6	28	75	66,5	890

Mounting accessories for cylinders

Mountings in aluminium for compact cylinders UNITOP



Main features

32 ÷ 100



ASV..ALIS+V

Bores Ø

AB7

Type



RP 107P

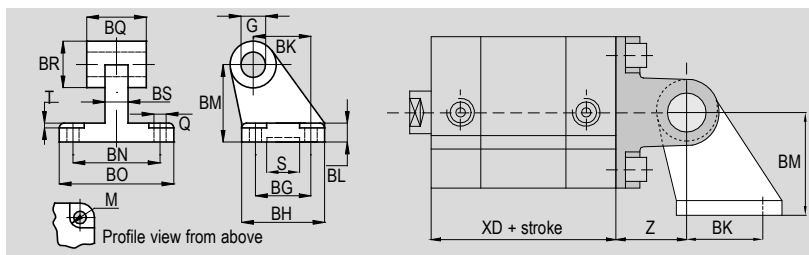

Technical data

Type	Description	Material	Treatment
ASV..ALIS+V	Mounting for cylinders in aluminium. Rear 90° hinge. For mounting with rear female clevis type CF. Supplied with screws.	Die-cast aluminium	Sifting

Dimensions

For cylinder Ø mm	Code	Item	Q	M	BG	BH	BK	BL	BM	BN	BO	BS	BR	G	T	S	BQ	XD	Z	Weight (g)	
32	042081	ASV032ALIS+V	6,6	11	18	31	21	8	32	38	51	10	20	10	1,6	10,5	26	-0,2 -0,6	44,5	22	-
40	042082	ASV040ALIS+V	6,6	11	22	35	24	10	36	41	54	15	22	12	1,6	10,5	28		45,5	25	-
50	042083	ASV050ALIS+V	9	15	30	45	33	12	45	50	65	16	26	12	1,6	10,5	32		45,5	27	-
63	042084	ASV063ALIS+V	9	15	35	50	37	14	50	52	67	16	30	16	1,6	10,5	40		50	32	-
80	042085	ASV080ALIS+V	11	18	40	60	47	14	63	66	86	20	30	16	2,5	10,5	50		56	36	-
100	042086	ASV100ALIS+V	11	18	50	70	55	17	71	76	96	20	38	20	2,5	10,5	60		66,5	41	-

Main features

32 ÷ 100



CM..ALIS+V

Bores Ø

MP4

Type

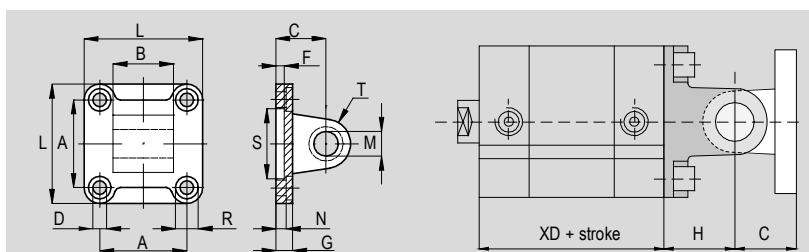

Technical data

Type	Description	Material	Treatment
CM..ALIS+V	Mounting for cylinders in aluminium. Rear eye. For mounting with rear female clevis type CF. Supplied with screws.	Die-cast aluminium	Sifting

Dimensions

For cylinder Ø mm	Code	Item	A	L	D	R	N	G	S	F	C	M	T	B	XD	H	Weight (g)	
32	042061	CM032ALIS+V	32,5	45	6,6	11	5,5	9	30	5	22	10	10	26	-0,2 -0,6	44,5	22	-
40	042062	CM040ALIS+V	38	52	6,6	11	5,5	9	35	5	25	12	12	28		45,5	25	-
50	042063	CM050ALIS+V	46,5	65	9	15	6,5	11	40	5	27	12	12	32		45,5	27	-
63	042064	CM063ALIS+V	56,5	75	9	15	6,5	11	45	5	32	16	16	40		50	32	-
80	042065	CM080ALIS+V	72	95	11	18	10	14	45	5	36	16	16	50		56	36	-
100	042066	CM100ALIS+V	89	115	11	18	10	14	55	5	41	20	20	60		66,5	41	-

Mounting accessories for cylinders

Mountings in steel for compact cylinders UNITOP



1 - CYLINDERS

Main features

32 ÷ 100



CF..AQUN



Bores Ø

Type

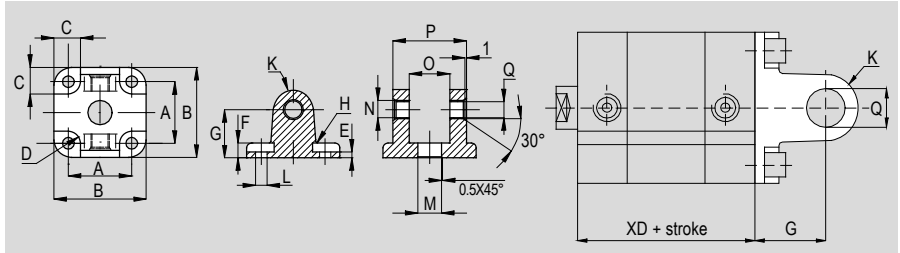

Technical data

Type	Description	Material	Treatment
CF..AQUN	Mounting for cylinders in steel. Rear clevis. Pin type SEC..AQIS to be ordered separately, see page 1.98.5. Mounting screws to be ordered separately, see page 1.101.40.	Steel A105	Black cataphoresis

Dimensions

For cylinder Ø mm	Code	Item	A	B	C	D	E	F	G	H	K	L	M	N	O	P	Q	XD	Weight (g)
32	040741	CF032AQUN	32	48	-	11	5,5	9	22	2,5	10	6,6	14	12	26	45	10	44,5	178
40	040742	CF040AQUN	42	58	-	11	5,5	9	25	2,5	12,5	6,6	14	14	28	52	12	45,5	313
50	040743	CF050AQUN	50	66	15,5	7,5	6,5	11	27	2,5	12,5	9	18	14	32	60	12	45,5	431
63	040744	CF063AQUN	62	83	-	15	6,5	11	32	4	15	9	18	18	40	70	16	50	707
80	040745	CF080AQUN	82	102	19	9	10	13	36	4	15	11	23	18	50	90	16	56	1213
100	040746	CF100AQUN	103	123	19	9	10	15	41	4	20	11	28	23	60	110	20	66,5	2200

Main features

20 ÷ 25



CM..AQUN



Bores Ø

Type

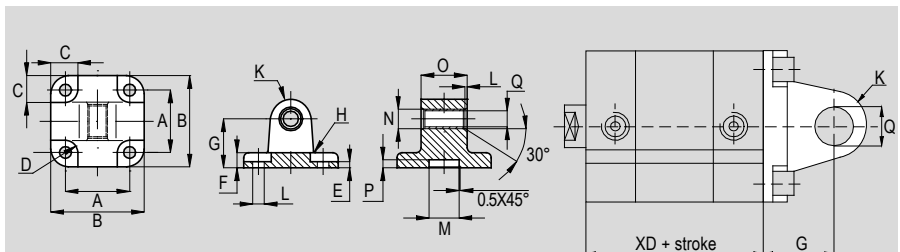

Technical data

Type	Description	Material	Treatment
CM..AQUN	Mounting for cylinders in steel. Rear eye. Mounting screws to be ordered separately, see page 1.101.40.	Steel A105	Black cataphoresis

Dimensions

For cylinder Ø mm	Code	Item	A	B	C	D	E	F	G	H	K	L	M	N	O	P	Q	XD	Weight (g)
20	040732	CM020AQUN	22	34	11	5	2,6	6	20	2	8	5,5	12	10	16	3	8	38	64
25	040733	CM025AQUN	26	38	11	5	2,6	6	20	2	8	5,5	12	10	16	3	8	39,5	80

Mounting accessories for cylinders

Mountings in steel for compact cylinders UNITOP



Main features

12 ÷ 25



FL..AQUN

Type

Bores Ø

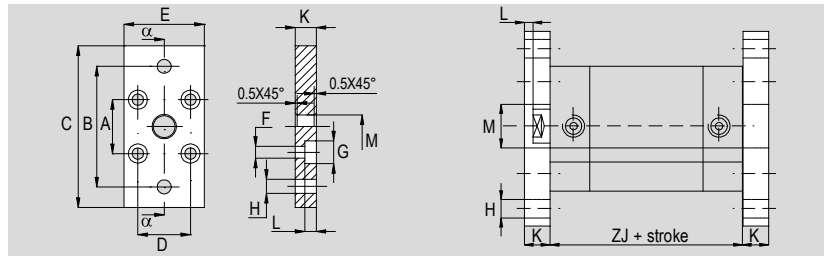

Technical data

Type	Description	Material	Treatment
FL..AQUN	Mounting for cylinders in steel. Flange. For front or rear mounting. Mounting screws to be ordered separately, see page 1.101.40.	Fe 37	White zinc plating

Dimensions

For cylinder Ø mm	Code	Item	A	B	C	D	E	F	G	H	K	L	M	XD	Weight (g)
12	040751	FL012016AQUN	18	43	55	18	29	4,5	9	5,5	10	5,4	10	38	34
16															
20	040752	FL020AQUN	22	55	70	22	36	5,5	10	6,6	10	5,4	12	38	55
25	040753	FL025AQUN	26	60	76	26	40	5,5	10	6,6	10	5,4	12	39,5	68

Main features

32 ÷ 100



FL..AQUN

Type

Bores Ø

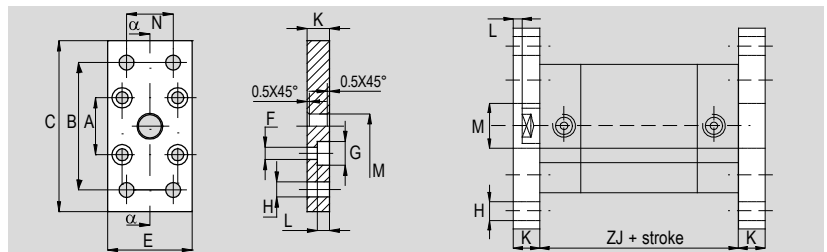

Technical data

Type	Description	Material	Treatment
FL..AQUN	Mounting for cylinders in steel. Flange. For front or rear mounting. Mounting screws to be ordered separately, see page 1.101.40.	Fe 37	White zinc plating

Dimensions

For cylinder Ø mm	Code	Item	A	B	C	D	E	F	G	H	K	L	M	N	XD	Weight (g)
32	040754	FL032AQUN	32	65	80	32	50	6,6	11	7	10	6,4	14	32	44,5	260
40	040755	FL040AQUN	42	82	102	42	60	6,6	11	9	10	6,4	14	36	45,5	420
50	040756	FL050AQUN	50	90	110	50	68	9	15	9	12	8,6	18	45	45,5	600
63	040757	FL063AQUN	62	110	130	62	87	9	15	9	15	8,6	18	50	50	1200
80	040758	FL080AQUN	82	135	160	82	107	11	18	12	15	10,6	23	63	56	1800
100	040759	FL100AQUN	103	163	190	103	128	11	18	14	15	10,6	28	75	66,5	2550

Mounting accessories for cylinders

Mountings in steel for compact cylinders UNITOP



1 - CYLINDERS

Main features

16 ÷ 32



PB..AQUN

Bores Ø

Type

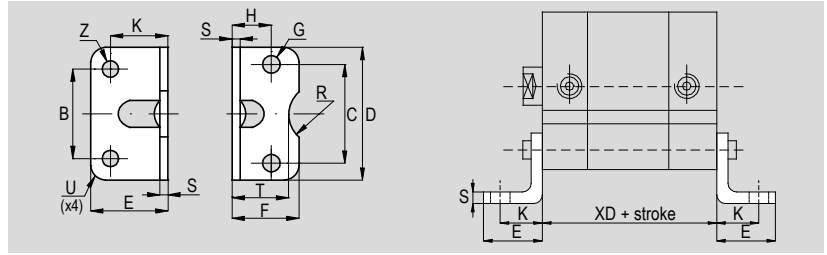

Technical data

Type	Description	Material	Treatment
PB..AQUN	Mounting for cylinders in steel. Low foot. For front or rear mounting. Supplied individually. Mounting screws to be ordered separately, see page 1.101.40.	Fe 37	White zinc plating

Dimensions

For cylinder Ø mm	Code	Item	C	B	D	E	F	G	H	K	S	T	R	U	Z	XD	Weight (g)
12	040761	PB012/016AQUN	18	18	30	17,5	17,5	4,4	13	13	3	15	9	2	5,5	38	20
16																	
20	040762	PB20AQUN	22	22	36	22	22	5,4	16	16	4	17	10	2	6,6	38	32
25	040763	PB25AQUN	26	26	40	22	23	5,4	17	16	4	19	11	2	6,6	39,5	38
32	040764	PB32AQUN	32	32	50	26	24	6,6	16	18	5	20	12	2	6,6	44,5	66

Main features

40 ÷ 100



PB..AQUN

Bores Ø

Type

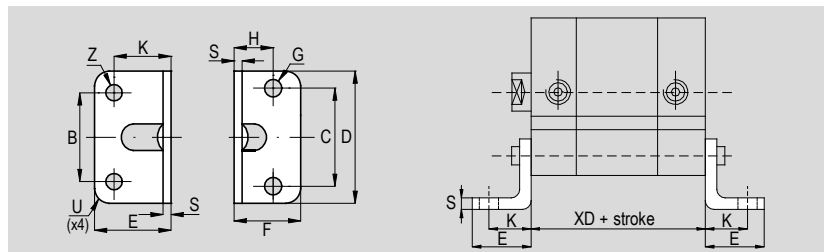

Technical data

Type	Description	Material	Treatment
PB..AQUN	Mounting for cylinders in steel. Low foot. For front or rear mounting. Supplied individually. Mounting screws to be ordered separately, see page 1.101.40.	Fe 37	White zinc plating

Dimensions

For cylinder Ø mm	Code	Item	C	B	D	E	F	G	H	K	S	U	Z	XD	Weight (g)
40	040765	PB040AQUN	42	42	60	28	29,5	6,6	21,5	20	5	5	9	45,5	100
50	040766	PB050AQUN	50	50	68	32	30	9	22	24	6	5	9	45,5	150
63	040767	PB063AQUN	62	62	84	39	39	9	28,5	27	6	5	11	50	250
80	040768	PB080AQUN	82	82	102	42	36,5	11	24,5	30	8	5	11	56	380
100	040769	PB100AQUN	103	103	123	45	38,5	11	26,5	33	8	5	13,5	66,5	500

Mounting accessories for cylinders

Mountings in steel for compact cylinders UNITOP



Main features

12 ÷ 25



CF

Bores Ø

MP3

Type

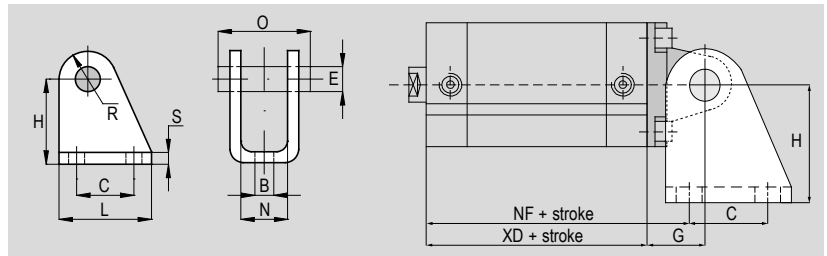

Technical data

Type	Description	Material	Treatment
CF..	Mounting for cylinders in steel. Rear 90° hinge. For mounting with rear eye. Supplied with pin and two seeger.	Steel	White zinc plating

Dimensions

For cylinder Ø mm	Code	Item	B	E	C	H	L	N	O	R	S	NF	XD	G	Weight (g)
12	040049	CF12-16+P	5,5	6	15	27	25	12,1	23	7	3	73	38	16	75
16															
20	040050	CF20-25+P	6,6	8	20	30	32	16,1	29,5	10	4	91	38	20	78
25												100	39,5		

Main features

32 ÷ 100



ASV..AQIS

Bores Ø

AB7

Type



RP 107P

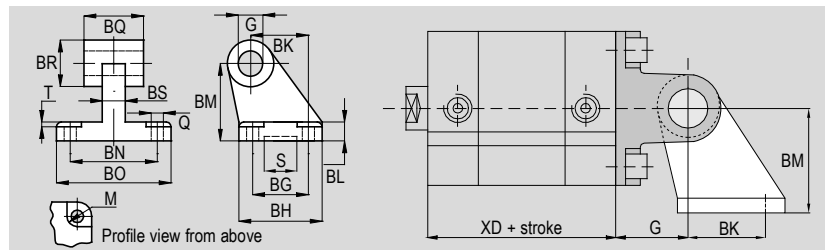

Technical data

Type	Description	Material	Treatment
ASV..AQIS	Mounting for cylinders in steel. Rear 90° hinge. For mounting with rear female clevis CF. Mounting screws to be ordered separately, see page 1.101.30.	Steel A 105	Black cataphoresis

Dimensions

For cylinder Ø mm	Code	Item	Q	M	BG	BH	BK	BL	BM	BN	BO	BS	BR	G	T	S	BQ	XD	Z	Weight (g)
32	040381	ASV032AQIS	6,6	11	18	31	21	8	32	38	51	10	20	10	6,5	20	26	44,5	22	184
40	040382	ASV040AQIS	6,6	11	22	35	24	10	36	41	54	10	22	12	8,5	20	28	45,5	25	265
50	040383	ASV050AQIS	9	15	30	45	33	12	45	50	65	14	26	12	10,5	20	32	45,5	27	472
63	040384	ASV063AQIS	9	15	35	50	37	12	50	52	67	14	30	16	10,5	20	40	50	32	580
80	040385	ASV080AQIS	11	18	40	60	47	14	63	66	86	18	30	16	12,5	20	50	56	36	1157
100	040386	ASV100AQIS	11	18	50	70	55	15	71	76	96	20	36	20	12,5	20	60	66,5	41	1612

Mounting accessories for cylinders

Mountings in steel for compact cylinders UNITOP



Main features

32 ÷ 100 **ISO** CM..AQIS+V

Bores Ø

MP4

Type

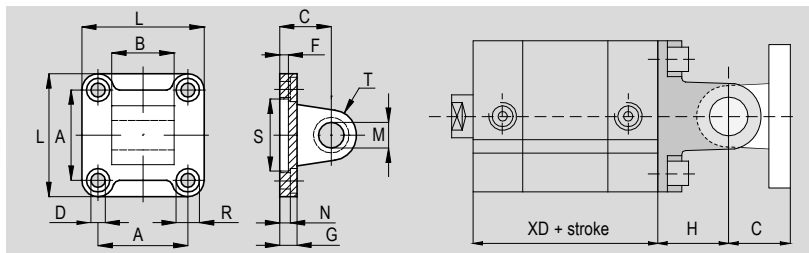

Technical data

Type	Description	Material	Treatment
CM..AQIS+V	Mounting for cylinders in steel. Rear eye. For mounting with rear female clevis type CF. Supplied with screws.	Steel A 105	Black cataphoresis

Dimensions

For cylinder Ø mm	Code	Item	A	L	D	R	N	G	S	F	C	M	T	B	XD	H	Weight (g)	
32	040521	CM032AQIS+V	32,5	45	6,6	11	5,5	10	30	5	22	10	10	26	-0,2 -0,6	51	7	202
40	040522	CM040AQIS+V	38	55	6,6	11	5,5	10	35	5	25	12	12	28		52	7	300
50	040523	CM050AQIS+V	46,5	65	9	15	6,5	10	40	5	27	12	12	32		53	8	422
63	040524	CM063AQIS+V	56,5	75	9	15	6,5	12	45	5	32	16	16	40		57	8	736
80	040525	CM080AQIS+V	72	95	11	18	10	14	45	5	36	16	16	50		64	10	1298
100	040526	CM100AQIS+V	89	115	11	18	10	16	55	5	41	20	20	60		77	10	2202

1 - CYLINDERS

Mounting accessories for cylinders

Mountings in aluminium for short stroke cylinders



Main features

16 ÷ 63

P..ALB

Bores Ø

Type

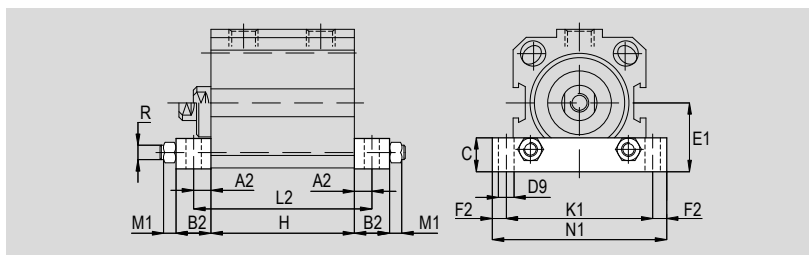

Technical data

Type	Description	Material
P..ALB	Mounting for cylinders in aluminium. Feet. For rear and front mounting. The accessory require tie rods, to be ordered separately. The kit include two feet.	Aluminium

Dimensions

For cylinder Ø mm	Code	Item	A ₂	B ₂	C	ØD ₉	E ₁	F ₂	K ₁	L ₂	M ₁	N ₁	ØR	Weight (g)
16	040087	P16ALB	5	10	10	3,5	17	5	30	H*+10	2,4	40	M3	-
20	040088	P20ALB	5	10	10	5,5	18	5	40	H*+10	4	50	M5	-
25	040095	P25ALB	6	12	12	5,5	20	7,5	45	H*+12	4	60	M5	-
32	040089	P32ALB	6	12	12	5,5	24	5	50	H*+12	4	60	M5	-
40	040090	P40ALB	6	12	12	5,5	27,5	5	60	H*+12	4	70	M5	-
50	040091	P50ALB	7,5	15	15	6,5	32,5	5	70	H*+15	5	80	M6	-
63	040092	P63ALB	7,5	15	15	8,5	40	7,5	85	H*+15	6,5	100	M8	-

* Quote H is depending by stroke and bore of the cylinder.

Main features

80 ÷ 100

P..ALB

Bores Ø

Type

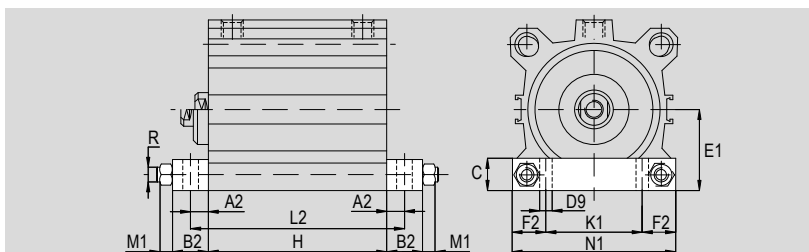

Technical data

Type	Description	Material
P..ALB	Mounting for cylinders in aluminium. Feet. For rear and front mounting. The accessory require tie rods, to be ordered separately. The kit include two feet.	Aluminium

Dimensions

For cylinder Ø mm	Code	Item	A ₂	B ₂	C	ØD ₉	E ₁	F ₂	K ₁	L ₂	M ₁	N ₁	ØR	Weight (g)
80	040093	P80ALB	10	20	20	8,5	50	20	60	H*+20	6,5	100	M8	-
100	040094	P100ALB	10	20	20	10,5	62	22	80	H*+20	8	124	M10	-

* Quote H is depending by stroke and bore of the cylinder.

Mounting accessories for cylinders

Mountings in aluminium for short stroke cylinders



Main features

16 ÷ 100 **CM..ALB**

Bores Ø

Type

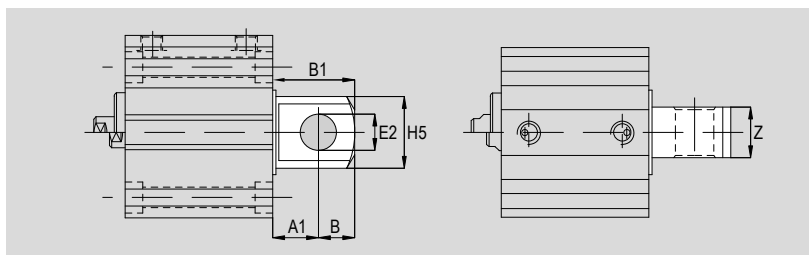

Technical data

Type	Description	Material
CM..ALB	Mounting for cylinders in aluminium. Back head with integrated rear eye. The accessory necessarily has to be ordered with the cylinder.	Aluminium

Dimensions

For cylinder Ø mm	Code	Item	A ₁	B	ØE ₂ h8	ØH ₅	Z	B ₁	Weight (g)
16	040070	CM16ALB	8	6	6	12	7	14	-
20	040071	CM20ALB	10	8	8	16	9	18	-
25	040072	CM25ALB	10	8	8	16	9	18	-
32	040073	CM32ALB	13	10	10	20	14	23	-
40	040074	CM40ALB	15	12	12	24	16	27	-
50	040075	CM50ALB	15	12	12	24	17	27	-
63	040076	CM63ALB	19	16	16	32	22	35	-
80	040077	CM80ALB	19	16	16	32	22	35	-
100	040078	CM100ALB	23	20	20	40	26	43	-

Mounting accessories for cylinders

Mountings in aluminium for rodless cylinders



Main features

18 ÷ 63

CL..S

Bores Ø

Type

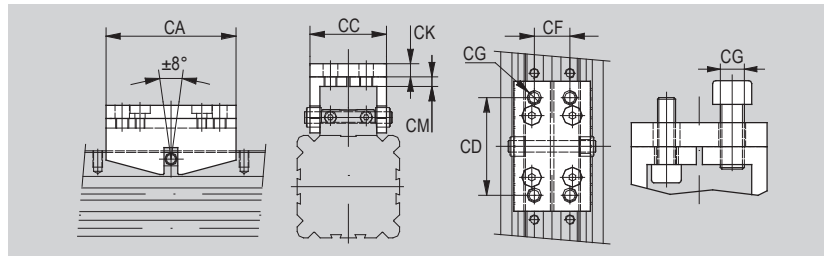

Technical data

Type	Description	Material
CL..S	Mounting for cylinders in aluminium. Light flexible coupling. Can be mounted if one guide should be connected to an existing rodless cylinder. Allow effortless transfer of action. The kit include: 1 coupling, 1 pin, 1 seeger, 2 spacers. Matching with type S1 (without option B mounted) and S2 only.	Anodised aluminium

Dimensions

For cylinder Ø mm	Code	Item	CA	CC	CD	CF	CG	CK	CM	Weight (g)
18	559038	CL18S	50	25,5	30	9	M5	4	4	-
25	559037	CL25S	60	30	40	14	M5	4	4	-
32	559032	CL32S	70	37	50	16	M6	6	6	-
40	559033	CL40S	80	47	60	22	M8	8	8	-
50	559034	CL50S	90	56	70	30	M8	8	8	-
63	559035	CL63S	100	73	80	40	M10	8	8	-

Main features

18 ÷ 63

C..S

Bores Ø

Type

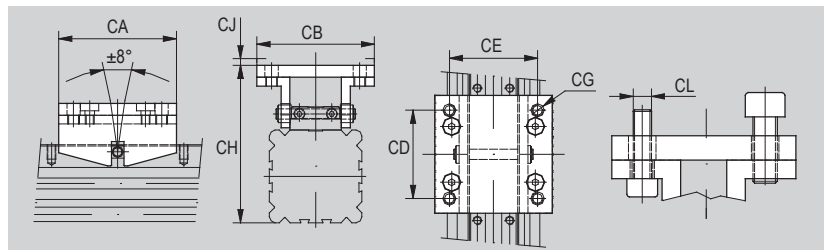

Technical data

Type	Description	Material
C..S	Mounting for cylinders in aluminium. Heavy flexible coupling. Can be mounted if one guide should be connected to an existing rodless cylinder. Allow effortless transfer of action. Compared with the light flexible coupling, this accessory should be used in case the forces are higher. The kit include: 1 coupling, 1 pin, 1 seeger, 2 spacers. Matching with type S1 (without option B mounted) and S2 only.	Anodised aluminium

Dimensions

For cylinder Ø mm	Code	Item	CA	CB	CD	CE	CG	CH	CJ	CL	Weight (g)
18	559001	C18S	50	41,5	30	34	M5	54	2,5	M4	-
25	559002	C25S	60	50	40	38	M5	70	3	M4	-
32	559003	C32S	70	60	50	48	M6	86	3,5	M5	-
40	559004	C40S	80	80	60	60	M8	107	4,5	M6	-
50	559005	C50S	90	95	70	70	M8	123	4,5	M6	-
63	559006	C63S	100	120	80	90	M10	145,5	5	M8	-

Mounting accessories for cylinders

Mountings in aluminium for rodless cylinders



1 - CYLINDERS

Main features

18 ÷ 63 **SID..S**
Bores Ø Type

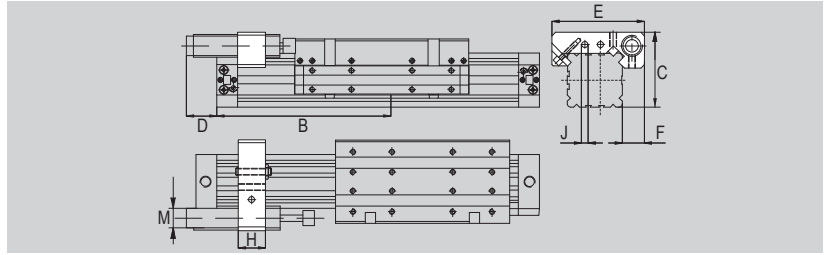

Technical data

Type	Description	Material
SID..S	Mounting for cylinders in aluminium. Mid support for shock absorbers. Matching with type S3, S5 and S6 only. Shock absorbers to be ordered separately, see page 1.105.1	Anodised aluminium

Dimensions

For cylinder Ø mm	Code	Item	B		F	D max	E	C	M	J	H	Weight (g)
			S3-S6	S5								
18	559060	SID18S	111,5	89	13	25	62	43	M10x1	-	15	-
25	559061	SID25S	140	107,5	15	60	75	56	M14x1,5	M8X1	20	-
32	559062	SID32S	160	117,5	18	60	84	69	M14x1,5	M8X1	20	-
40	559063	SID40S	203	148	23	96	105	86	M25x1,5	M8X1	30	-
50	559064	SID50S	223	158	24	96	126	104	M25x1,5	M8X1	30	-
63	559065	SID63S	284	194	25	80	140	116	M25x1,5	M8X1	40	-

Main features

18 ÷ 63 **STD..S**
Bores Ø Type

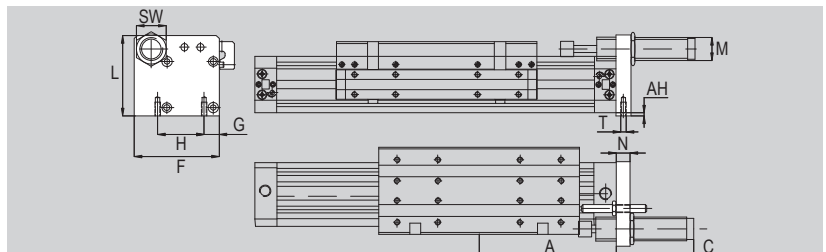

Technical data

Type	Description	Material
STD..S	Mounting for cylinders in aluminium. End support for shock absorbers with adjustable mechanical stop. Matching with type S3, S5 and S6 only. Shock absorbers to be ordered separately, see page 1.105.1	Anodised aluminium

Dimensions

For cylinder Ø mm	Code	Item	A		AH	C	F	G	H	M	N	SW	L	T	Weight (g)
			S3-S6	S5											
18	559070	STD18S	80	57,5	2	32	43.5	8	23.5	M10x1	8	13	45	M3x10	-
25	559071	STD25S	100	67,5	2	65	57	12,5	33	M14x1,5	10	17	58	M4x10	-
32	559072	STD32S	120	77,5	3	70	70	14,5	41	M14x1,5	10	17	71,5	M5x12	-
40	559073	STD40S	150	95	3	78	93	16	51	M25x1,5	15	32	89	M6x15	-
50	559074	STD50S	180	105	3	80	102	22,5	63	M25x1,5	15	32	105	M8x20	-
63	559075	STD63S	215	125	4,5	80	118.5	20	78	M25x1,5	15	32	122	M8x20	-

Mounting accessories for cylinders

Mountings in aluminium for rodless cylinders



Main features

18 ÷ 63

SI..S

Bores Ø

Type

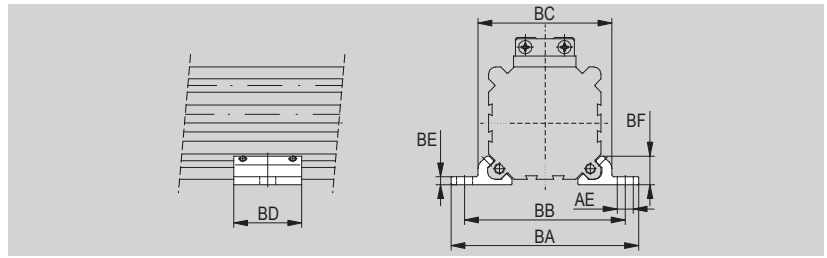

Technical data

Type	Description	Material
SI..S	Mounting for cylinders in aluminium. Light mid support. The kit include: 2 light mid supports and 8 mounting screws. The mid supports are to be used as a basket in case of barrel bending. It is recommended to install the stand at the end of the barrel and for avoid sliding, to secure it with two coarse-headed front screws. Matching with type S1 (without option B mounted), S2 and S4 only.	Anodised aluminium

Dimensions

For cylinder Ø mm	Code	Item	ØAE	BA	BB	BC	BD	BE	BF	Weight (g)
18	559020	SI18S	6	56	46	36,5	23	2,5	8,25	-
25	559021	SI25S	6	70	60	50	28	3,5	11	-
32	559022	SI32S	7	85	73	61,5	33	4	13,8	-
40	559023	SI40S	9	105	90	75	38	4,5	16	-
50	559024	SI50S	9	122	106	91	43	5	19	-
63	559025	SI63S	11	144	125	107	48	6	22	-

Main features

18 ÷ 63

SIP..S

Bores Ø

Type

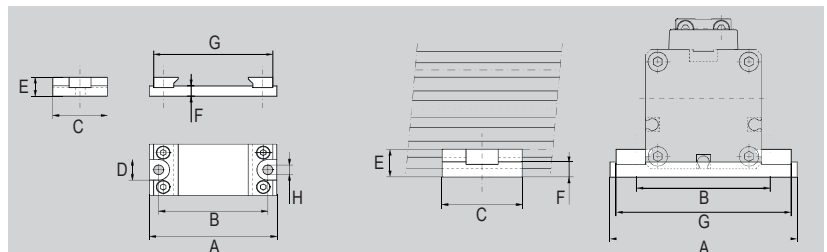

Technical data

Type	Description	Material
SIP..S	Mounting for cylinders in aluminium. Heavy mid support. The kit include: 2 heavy mid supports and 8 mounting screws. The mid supports are to be used as a basket in case of barrel bending. It is recommended to install the stand at the end of the barrel and for avoid sliding, to secure it with two coarse-headed front screws. Matching with type S1 (without option B mounted), S2 and S4 only.	Anodised aluminium

Dimensions

For cylinder Ø mm	Code	Item	ØA	B	C	D	E	F	G	ØH	Weight (g)
18	559102	SIP18S	56	46	30	12	11	6	50.6	5.5	-
25	559103	SIP25S	70	60	30	12	13	6	65.5	5.5	-
32	559104	SIP32S	85	73	40	12.5	15	6	77.5	6.6	-
40	559105	SIP40S	105	90.5	40	16	18	8	90.5	9	-
50	559106	SIP50S	122	105	40	16	20.5	8	107.5	9	-
63	559107	SIP63S	144	125	50	19	21.5	8	122.5	11	-

Mounting accessories for cylinders

Mountings in aluminium for rodless cylinders



1 - CYLINDERS

Main features

18 ÷ 63

P..S

Bores Ø

Type

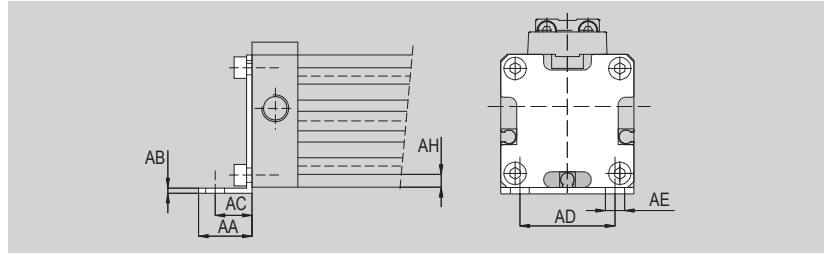

Technical data

Type	Description	Material
P..S	Mounting for cylinders in aluminium. Light foot. For mounting on rodless cylinder in four possible positions. The kit include: 2 light feet e 8 mounting screws. Matching with type S1, S2, S3, S4, S5 and S6.	Anodised aluminium

Dimensions

For cylinder Ø mm	Code	Item	AA	AB	AC	AD	ØAE	AH	Weight (g)
18	559010	P18S	15	2	10	20	6	2	-
25	559011	P25S	18	2	12,5	30	6	2	-
32	559012	P32S	20	2,5	13,5	40	7	3	-
40	559013	P40S	30	3	17,5	50	9	3,5	-
50	559014	P50S	28	3	20	60	9	3	-
63	559015	P63S	30	3	21	75	11	4,5	-

Main features

18 ÷ 63

PP..S

Bores Ø

Type

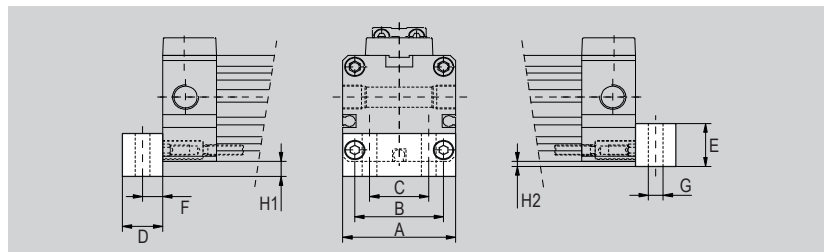

Technical data

Type	Description	Material
PP..S	Mounting for cylinders in aluminium. Heavy foot. For mounting on rodless cylinder in four possible positions. The kit include: 2 heavy feet e 4 mounting screws. Matching with type S1, S2, S3, S4, S5 and S6	Anodised aluminium

Dimensions

For cylinder Ø mm	Code	Item	A	B	C	D	E	F	ØG	H1	H2	Weight (g)
18	559096	PP18S	30	23.5	14	10	14.5	5	4.5	6	2	-
25	559097	PP25S	42	33	22	15	17	7.5	5.5	6	2	-
32	559098	PP32S	52	41	23.5	15	20	7.5	7	6	3	-
40	559099	PP40S	63	51	30	15	23	7.5	9	8	3	-
50	559100	PP50S	78	63	39	16	26	8	9	8	3	-
63	559101	PP63S	93	78	52	20	27.5	10	11	8	4.5	-

Mounting accessories for cylinders

Mountings for hand grips



Main features

10 ÷ 32

PM

Bores Ø

Type

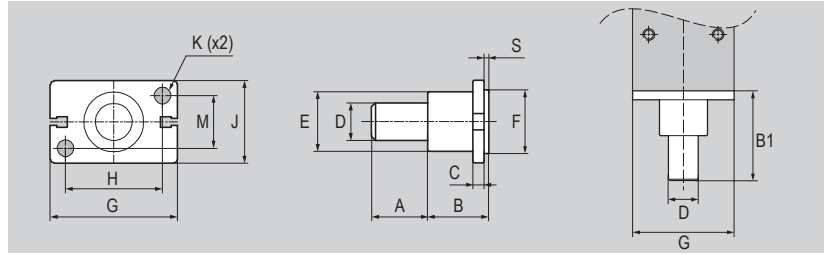

Technical data

Type	Description	Material
..PM	Mounting for hand grips in aluminium. Mounting with male pin. Compatible with types PAB - PAC - PPB.	Aluminium

Dimensions

For cylinder Ø mm	Code	Item	A	B	B1	C	ØD	ØE	ØF	G	H	M	J	ØK	S	Weight (g)
10	170655	10PM	10	10	18,7	2	8	12	11	23	17	10	16	3,5	1,3	-
12	170665	12PM	10	10	18,7	2	8	12	13	27	20	10	16	3,5	1,3	-
16	075058	16PM	15	15	28,7	3	10	16	17	34	26	14	22	4,5	1,3	-
20	075059	20PM	15	15	28,7	3	10	18	21	45	35	16	26	5,5	1,3	-
25	075064	25PM	25	17	40,7	5	14	26	26	52	40	20	32	6,5	1,3	-
32	075065	32PM	25	20	43,7	6	16	30	34	60	46	26	40	6,6	1,3	-

Main features

10 ÷ 32

PF

Bores Ø

Type

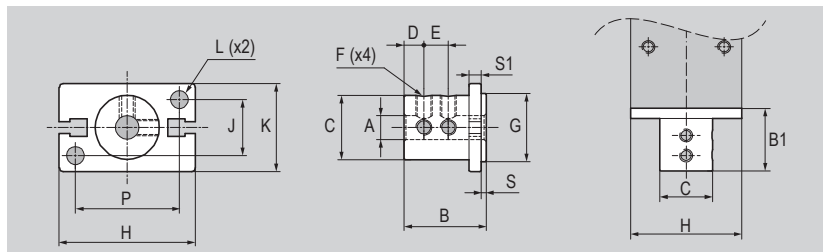

Technical data

Type	Description	Material
..PF	Mounting for hand grips in aluminium. Mounting with female pin. Compatible with types PAB - PAC - PPB - PPC.	Aluminium

Dimensions

For cylinder Ø mm	Code	Item	ØA	B	B1	ØC	D	E	F	ØG	H	P	J	K	ØL	S	S1	Weight (g)
10	170656	10PF	4	15	13,7	10	5	-	M3x0,5p	11	23	17	10	16	3,5	1,3	3	-
12	170666	12PF	4	15	13,7	12	5	-	M3x0,5p	13	27	20	10	16	3,5	1,3	3	-
16	075066	16PF	6	20,5	19,2	16	5	6	M4x0,7p	17	34	26	14	22	4,5	1,3	3	-
20	075067	20PF	8	20,5	19,2	20	7	7	M4x0,7p	21	45	35	16	26	5,5	1,3	3	-
25	075068	25PF	10	30,5	29,2	25	8	10	M4x0,7p	26	52	40	20	32	6,5	1,3	3	-
32	075069	32PF	12	40,5	39,2	32	10	15	M4x0,7p	34	60	46	26	40	6,5	1,3	3	-

Mounting accessories for cylinders

Mountings for hand grips



Main features

25 ÷ 100

PTD

Bores Ø

Type

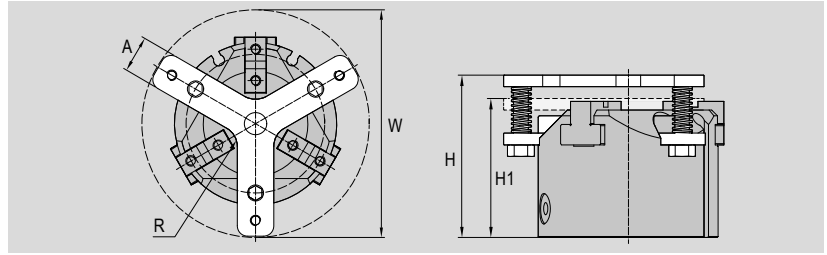
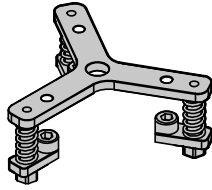

Technical data

Type	Description	Material
..PTD	Mounting for hand grips in stainless steel. Mounting plate. Supplied with screws and nuts. Compatible with type PPE.	Stainless Steel

Dimensions

For cylinder Ø mm	Code	Item	A	R	W	H	H ₁	Weight (g)
25	170657	25PTD	9	6	70	46.5	40	-
32	170658	32PTD	10	6	79	51	45	-
40	170659	40PTD	13	8	87	56	48	-
50	170660	50PTD	14	8	96	64	56	-
63	170661	63PTD	16	8	121	77	67	-
80	170662	80PTD	20	10	140	92	82	-
100	170663	100PTD	25	15	171	110	95	-

Mounting accessories for cylinders

Connecting bracket for slide units



Main features

32 ÷ 100

scsg

Bores Ø

Type

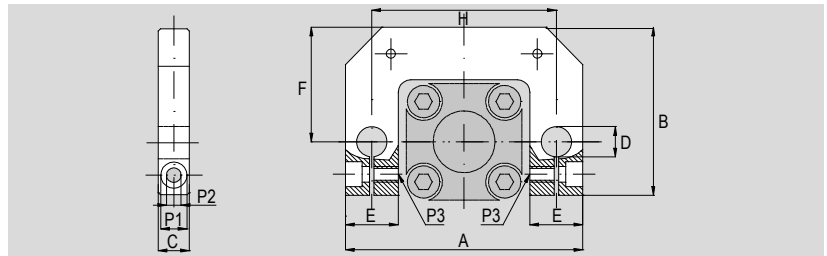

Technical data

Type	Description	Material
SCSG..	Connecting bracket for slide units. For mounting on slide units for cylinders ISO 15552. Supplied with screws.	Anodised aluminium

Dimensions

For cylinder Ø mm	Code	Item	A	B	C	ØD	E	F	H	P ₁	P ₂	P ₃	Weight (g)
32	077901	SCSG032	95	68	12	12	21	46	74	10,5	6,5	M6	-
40	077902	SCSG040	113	78	15	15	26	56	87	10,5	6,5	M6	-
50	077903	SCSG050	135	98	17	20	30	66	104	10,5	6,5	M6	-
63	077904	SCSG063	149	118	17	20	31	78	119	13,5	8,5	M8	-
80	077905	SCSG080	187	142	20	25	39	99	148	13,5	8,5	M8	-
100	077906	SCSG100	211	163	20	25	39	114	172	13,5	8,5	M8	-

Mounting accessories for cylinders

Mounting screws for cylinders ISO 15552



Main features

32 ÷ 320



VTCEI

Hexagon socket flat head screws, conforming to UNI 5931 standards, in steel, suitable for mounting accessory of cylinders ISO 15552.



Bores Ø

5931

Type

32 ÷ 320



VBTR

Flat head allen screw, conforming to DIN 6912 standards, in steel, suitable for mounting accessory of cylinders ISO 15552.



Bores Ø

6912

Type

Technical data, matching and codes of screws in steel type VTCEI and type VBTR

For cylinder Ø mm	Code	Item	Compliance	Matching with mounting accessories							
				CF	CM	CFS	CMS	FLV	PB	CFA	CTA
Ø 32	040771	VTCEIM6x18	UNI 5931	●	●	●	●	-	●	-	-
	040782	VBTRM6x18	DIN 6912	-	-	-	-	●	-	-	-
	040691	VTCEIM6x20	UNI 5931	-	-	-	-	-	-	●	●
Ø 40	040771	VTCEIM6x18	UNI 5931	●	●	●	●	-	●	-	-
	040782	VBTRM6x18	DIN 6912	-	-	-	-	●	-	-	-
	040691	VTCEIM6x20	UNI 5931	-	-	-	-	-	-	●	●
	880174	VTCEIM6x25	UNI 5931	-	-	-	-	-	-	-	●
Ø 50	881144	VTCEIM8x16	UNI 5931	-	-	-	-	-	●	-	-
	040772	VTCEIM8x20	UNI 5931	●	●	●	●	-	-	●	-
	040783	VBTRM8x20	DIN 6912	-	-	-	-	●	-	-	-
	040692	VTCEIM8x25	UNI 5931	-	-	-	-	-	-	-	●
Ø 63	881144	VTCEIM8x16	UNI 5931	-	-	-	-	-	●	-	-
	040772	VTCEIM8x20	UNI 5931	●	●	●	●	-	-	-	-
	040783	VBTRM8x20	DIN 6912	-	-	-	-	●	-	-	-
	040692	VTCEIM8x25	UNI 5931	-	-	-	-	-	-	●	-
	880824	VTCEIM8x30	UNI 5931	-	-	-	-	-	-	-	●
Ø 80	040773	VTCEIM10x20	UNI 5931	-	-	-	-	-	●	-	-
	040784	VBTRM10x20	DIN 6912	-	-	-	-	●	-	-	-
	881228	VTCEIM10x25	UNI 5931	●	●	●	●	-	-	-	-
	040693	VTCEIM10x30	UNI 5931	-	-	-	-	-	-	-	●
Ø 100	040773	VTCEIM10x20	UNI 5931	-	-	-	-	-	●	-	-
	040784	VBTRM10x20	DIN 6912	-	-	-	-	●	-	-	-
	881228	VTCEIM10x25	UNI 5931	●	●	●	●	-	-	-	-
	040693	VTCEIM10x30	UNI 5931	-	-	-	-	-	-	●	-
	883537	VTCEIM10x35	UNI 5931	-	-	-	-	-	-	-	●
Ø 125	040774	VTCEIM12x25	UNI 5931	-	-	-	-	-	●	-	-
	883538	VTCEIM12x30	UNI 5931	●	●	●	●	-	-	-	-
	883539	VBTRM12x30	DIN 6912	-	-	-	-	●	-	-	-
Ø 160	040775	VTCEIM16x30	UNI 5931	●	●	●	●	-	●	-	-
	883540	VBTRM16x30	DIN 6912	-	-	-	-	●	-	-	-
	040695	VTCEIM16x40	UNI 5931	-	-	-	-	-	-	-	-
Ø 200	040775	VTCEIM16x30	UNI 5931	●	●	●	●	-	●	-	-
	883540	VBTRM16x30	DIN 6912	-	-	-	-	●	-	-	-
Ø 250	883542	VTCEIM20x35	UNI 5931	●	●	-	-	-	●	-	-
	883543	VBTRM20x35	DIN 6912	-	-	-	-	●	-	-	-
Ø 320	883544	VTCEIM24x40	UNI 5931	●	●	-	-	-	-	-	-
	883545	VBTRM24x40	DIN 6912	-	-	-	-	●	-	-	-

Key

● allowed matching; - not allowed matching

Mounting accessories for cylinders

Mounting nuts e growers for cylinders CNOMO



Main features

25 ÷ 200 **UNI DIN** D
Bores Ø 5589 936 Type

Nuts conforming to UNI 5589 and DIN 936 standards, in steel, suitable for mounting accessory of cylinders CNOMO.



Technical data, matching and codes of nuts in steel type D

For cylinder Ø mm	Code	Item	Compliance	Matching with mounting accessories				
				CF	AN	P	FL	PB
Ø 25 ÷ 40	041450	D6x1	UNI 5589	●	●	●	●	●
Ø 50 ÷ 63	041451	D8x1,25	UNI 5589	●	●	●	●	●
Ø 80 ÷ 100	041453	D10x1,5	UNI 5589	●	●	●	●	●
Ø 125	041460	D12x1,75	UNI 5589	●	●	●	●	●
Ø 160 ÷ 200	880207	D16x2	UNI 5589	●	●	●	●	●

Key

● allowed matching; - not allowed matching

Main features

25 ÷ 200 **DIN** M
Bores Ø 127 B Type

Grower conforming to DIN 127 B standards in steel, suitable for mounting accessory of cylinders CNOMO.



Technical data, matching and codes of grower in steel type M

For cylinder Ø mm	Code	Item	Compliance	Matching with mounting accessories				
				CF	AN	P	FL	PB
Ø 25 ÷ 40	880166	M6ZB	DIN 127 B	●	●	●	●	●
Ø 50 ÷ 63	880066	M8ZB	DIN 127 B	●	●	●	●	●
Ø 80 ÷ 100	078384	M10ZB	DIN 127 B	●	●	●	●	●
Ø 125	880784	M12ZB	DIN 127 B	●	●	●	●	●
Ø 160 ÷ 200	078401	M16ZB	DIN 127 B	●	●	●	●	●

Key

● allowed matching; - not allowed matching

Mounting accessories for cylinders

Mounting screws for compact cylinders ISO 21287



Main features

16 ÷ 125		VTCEI	Hexagon socket flat head screws, conforming to UNI 5931 standards, in steel, suitable for mounting accessory of compact cylinders ISO 21287.
Bores Ø	5931	Type	
16 ÷ 125		VBTR	Flat head allen screw, conforming to DIN 6912 standards, in steel, suitable for mounting accessory of compact cylinders ISO 21287.
Bores Ø	6912	Type	



Technical data, matching and codes of screws in steel type VTCEI and type VBTR

For cylinder Ø mm	Code	Item	Compliance	Matching with mounting accessories						
				CF	CM	CFS	CMS	FLV	PB	CTA
Ø 16	880220	VTCEIM4x12	UNI 5931	-	●	-	-	-	●	-
	880842	VTCEIM4x16	UNI 5931	-	-	-	-	●	-	-
Ø 20 ÷ 25	880517	VTCEIM5x14	UNI 5931	-	●	-	-	●	-	-
	880164	VTCEIM5x20	UNI 5931	-	-	-	-	-	●	-
Ø 32	040771	VTCEIM6x18	UNI 5931	●	●	●	●	-	●	-
	040782	VBTRM6x18	DIN 6912	-	-	-	-	●	-	-
	040691	VTCEIM6x20	UNI 5931	-	-	-	-	-	-	●
Ø 40	040771	VTCEIM6x18	UNI 5931	●	●	●	●	-	●	-
	040782	VBTRM6x18	DIN 6912	-	-	-	-	●	-	-
	040691	VTCEIM6x20	UNI 5931	-	-	-	-	-	-	●
	880174	VTCEIM6x25	UNI 5931	-	-	-	-	-	●	-
Ø 50	881144	VTCEIM8x16	UNI 5931	-	-	-	-	-	●	-
	040772	VTCEIM8x20	UNI 5931	●	●	●	●	-	-	-
	040783	VBTRM8x20	DIN 6912	-	-	-	-	●	-	-
	040692	VTCEIM8x25	UNI 5931	-	-	-	-	-	-	●
Ø 63	881144	VTCEIM8x16	UNI 5931	-	-	-	-	-	●	-
	040772	VTCEIM8x20	UNI 5931	●	●	●	●	-	-	-
	040783	VBTRM8x20	DIN 6912	-	-	-	-	●	-	-
	880824	VTCEIM8x30	UNI 5931	-	-	-	-	-	-	●
Ø 80	040773	VTCEIM10x20	UNI 5931	-	-	-	-	-	●	-
	040784	VBTRM10x20	DIN 6912	-	-	-	-	●	-	-
	881228	VTCEIM10x25	UNI 5931	●	●	●	●	-	-	-
	040693	VTCEIM10x30	UNI 5931	-	-	-	-	-	-	●
Ø 100	040773	VTCEIM10x20	UNI 5931	-	-	-	-	-	●	-
	040784	VBTRM10x20	DIN 6912	-	-	-	-	●	-	-
	881228	VTCEIM10x25	UNI 5931	●	●	●	●	-	-	-
	883537	VTCEIM10x35	UNI 5931	-	-	-	-	-	-	●
Ø 125	040774	VTCEIM12x25	UNI 5931	-	-	-	-	-	●	-
	883538	VTCEIM12x30	UNI 5931	●	●	●	●	-	-	-
	883539	VBTRM12x30	DIN 6912	-	-	-	-	●	-	-

Key
● allowed matching; - not allowed matching

Mounting accessories for cylinders

Mounting screws for compact cylinders UNITOP



Main features

12 ÷ 100



VTCEI

Hexagon socket flat head screws, conforming to UNI 5931 standards, in steel, suitable for mounting accessory of compact cylinders UNITOP.



Bores Ø

5931

Type

Technical data, matching and codes of screws in steel type VTCEI

For cylinder Ø mm	Code	Item	Compliance	Matching with mounting accessories			
				CF	CM	FL	PB
Ø 12 ÷ 16	880220	VTCEIM4x12	UNI 5931	-	●	-	●
	880842	VTCEIM4x16	UNI 5931	-	-	●	-
Ø 20 ÷ 25	880517	VTCEIM5x14	UNI 5931	-	●	●	-
	880164	VTCEIM5x20	UNI 5931	-	-	-	●
Ø 32 ÷ 40	880179	VTCEIM6x16	UNI 5931	-	-	●	-
	040771	VTCEIM6x18	UNI 5931	●	-	-	●
Ø 50	881144	VTCEIM8x16	UNI 5931	-	-	●	-
	040772	VTCEIM8x20	UNI 5931	●	-	-	●
Ø 63 ÷ 100	881228	VTCEIM10x25	UNI 5931	●	-	●	●

Key

● allowed matching; - not allowed matching

ADJUSTABLE

shock absorbers



Find out our
key products



Solution for most applications



Easy and intuitive choice



Excellent value for money



Wide availability



Fast delivery



Characteristics

Series of adjustable hydraulic shock absorbers de-energising the impact on the rod by the displacement of oil from one chamber to another. This displacement is controlled by a valve and a throttling mechanism according to the adjustment brought in. The adjustment is carried out by a nut set in the rear end. The adjusting field is from 0 to 9 and the nut is provided with a stopper grub screw. The optimal cushion is obtained moving the nut towards 9 if the cushion is too high at the beginning of the stroke; while moving the nut towards 0 if the cushion is too high near the end of the stroke. The best choice of the shock absorber could be done easily following the instructions on the side page. Supplied as standard in compliance with Reach and RoHS directives.



Type DR

from page 1.105.10



Adjustable hydraulic shock absorbers without mechanical stop. Is recommended an external mechanical stopper at 0,5 - 1 mm, before the end of the stroke.

Type DRF

from page 1.105.10



Adjustable hydraulic shock absorbers with mechanical stopper included.

How to choose

1. Precisely determine the data of the problem, that is the calculation factors m , v , F , x , s , in the table below.
2. Calculate the kinetic energy of the mass:

$$W_1 = 0,5 \cdot m \cdot v_2 \text{ (Nm)}$$
 Choose a cushioning with a capacity per cycle higher than the calculated value. The cushion length chosen must be used at point 3).
3. If there is an external motion force (hydraulic or pneumatic cylinder, motor, gravity, etc.) calculate the work done:

$$W_2 = F \cdot s \text{ (Nm)}$$
4. Calculate the total energy that must be dissipated per cycle:

$$W_3 = W_1 + W_2 \text{ (Nm)}$$
 Check that the value obtained is within the capacity limits of the chosen cushioning. Otherwise you must consider a cushioning with higher cushion length or diameter and in case calculate W_2 and W_3 again.
 It can be necessary to compare cushionings with different cushion lengths and calculate again each time.
5. It is better to choose a cushioning with a capacity 25 per cent higher than the required one in order to:
 - a) let following possible increases of the impact energy;
 - b) Work with safe margins when velocities are not easily valuable;
 - c) make sure that the cushioning lasts long, especially when working in dusty or contaminated environments.

6. Calculate the efficiency measurement:

$$ME = \frac{W_3 \cdot 2}{V_2} \text{ (Kg)}$$

Check that the value obtained is within the limits indicated for the chosen cushioning and this to get a linear and progressive cushion.

7. Were the "ME" out of the limits, you should choose a cushioning with a different capacity of efficiency measurement.
8. Varying the cushion length you can change the "ME"; however, at each variation of the cushion length you must remember to calculate the propelling energy of the point 3 again.
 Check whether the cushioning is condition to dissipate the energy generated by work frequency per hour into heat:

$$W_4 = W_3 \cdot X \text{ (Nm/h)}$$
9. Were the cushioning not in condition to dissipate it, you should choose among:
 - a) use of a cushioning with a higher capacity per hour taking care of calculating the point 3 again (were the cushion length different);
 - b) Use of a system with recirculation or external air/oil tank, both characterised by a higher capacity per hour;
 - c) cooling of the cushioning by air blow or another refrigerating fluid.

Factors

Symbol

W1	= Kinetic energy per cycle	(Nm)
W2	= Motion energy per cycle	(Nm)
W3	= Total energy per cycle	(Nm)
W4	= Total energy per hour	(Nm/h)
F	= Motion force	(N)
x	= Number of cycles per hour	(1/h)
s	= Cushioning length	(m)
v	= Mass speed	(m/s)
m	= Cushioned mass	(Kg)
ME	= Efficiency measurement	(Kg)

The shock absorbers are selected according to their energy absorbing capacity. The capacity values identify both the mass that can be cushioned and the energy that can be absorbed per cycle and hour.
 So the required performances must be compared with the table of the cushionings capacities to make sure that the energy can be absorbed, converted into heat and dissipated in the atmosphere.

Energy

The factors that must be considered at the moment of selection are:

- Kinetic energy (W_1): it is the energy generated by the weight and the velocity of the mass that must be cushioned.
- Motion energy (W_2): it is the work, produced by the motion force acting on the mass that must be cushioned, multiplied by the cushion length.
- Total energy per cycle (W_3): it is the sum of the 2 preceding values and is the energy that must be dissipated every cycle.
- Total energy per hour (W_4): it is the product of the total energy per cycle by the number of cycles per hour; so it is the energy the cushioning must dissipate every hour.
- Efficiency measurement (**ME**): it is the mass (theoretical), which, without motion force and at the same velocity of the real mass, would have a kinetic energy equal to the total energy per cycle (W_3) of the real application. It is not the mass that must be cushioned; it doesn't indicate the power supported by the cushioning.

Code key

Type	Shock absorber thread	Shock absorber stroke
DR	12	10
<div style="border: 1px solid black; padding: 5px; margin-bottom: 5px;">DR</div> <div style="border: 1px solid black; padding: 5px;">DRF</div>	<div style="border: 1px solid black; padding: 5px; text-align: center;">10x1 ÷ 25x1,5</div>	<div style="border: 1px solid black; padding: 5px; text-align: center;">8 mm ÷ 40 mm</div>

How to order

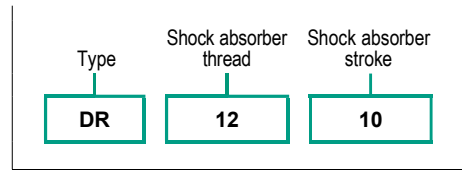

Standard materials

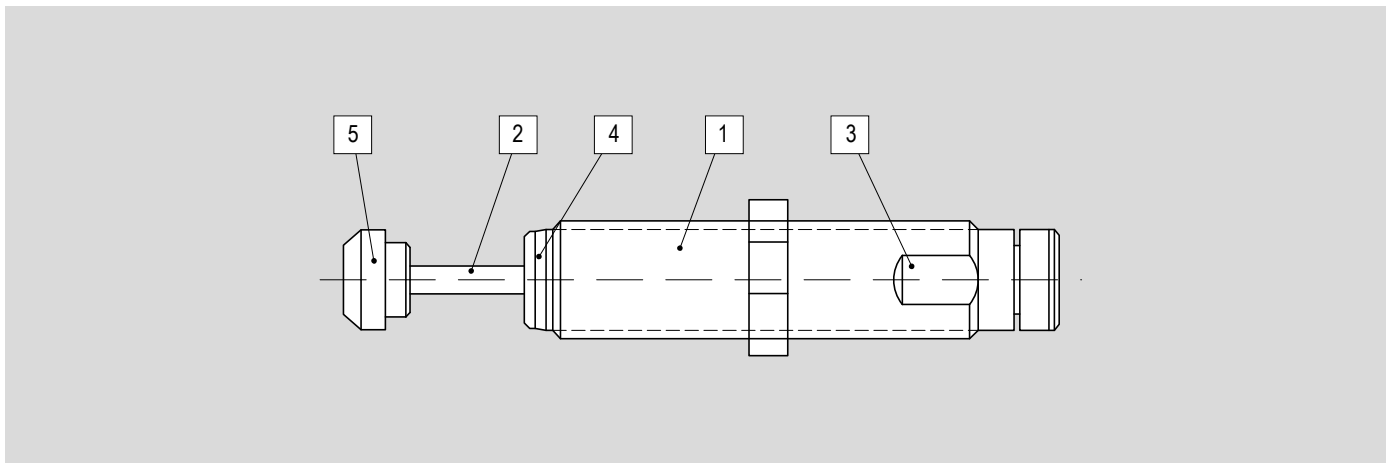

Position	Description	Materiale
1	Body	Burnished steel
2	Rod	Stainless Steel
3	Spring	Steel
4	Seals	NBR - Polyurethane (PU) - Elastomer
5	Absorber	Polymer

Main features

8 ÷ 10

Strokes mm

DR

Type



12,5 ÷ 40

Strokes mm

DRF

Type



Technical data

Type	DR	DRF
Description	Adjustable hydraulic shock absorbers without mechanical stopper	Adjustable hydraulic shock absorbers with mechanical stopper included
Temperature range	+5°C ÷ +70°C	+12°C ÷ +90°C
Strokes	8 - 10 mm	12,5 - 19,1 - 25,4 - 40 mm
Maximum impact speed	4 m/s	

Dimensions

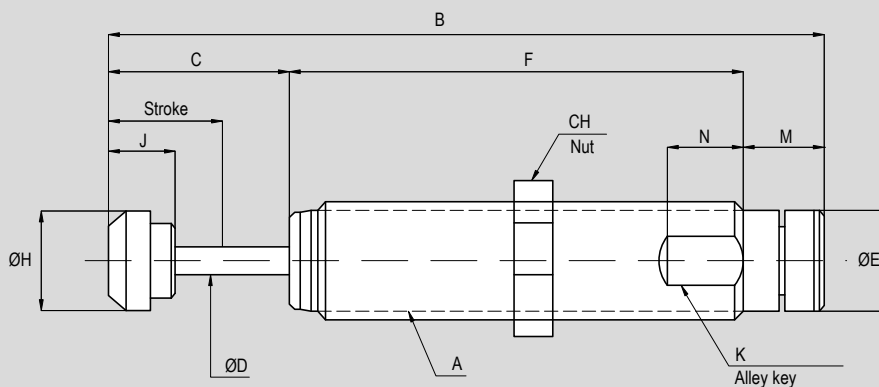

Code	Item	Stroke	A (thread)	B	C	ØD	ØE	F	N	ØH	K	J	M	CH	Maximum absorbing capacity (Nm)		Efficiency measurement		Weight (g)
															Per cycle (W ₃)	Per hour (W ₄)	min. (Kg.)	max. (Kg.)	
041801	DR1008	8	10x1	66,5	14,5	2,5	8,8	40	-	6	-	6,5	12	13	1,8	3600	0,2	10	26
041802	DR1210	10	12x1	84	18	3,5	10,8	60	-	8	-	8	6	14	4	6000	0,9	57	43
041803	DRF1412	12,5	14x1,5	87	17,5	8	12	61	12	12	12	10	8,5	17	17	35000	0,6	90	60
041804	DRF2019	19,1	20x1,5	117,9	30	4,8	16,8	74,7	12,7	16,8	18	11	13,2	24	25	45000	2,3	226	130
041805	DRF2525	25,4	25x1,5	142,6	36,3	6,3	22,4	89,7	12,7	22,9	23	11	16,6	30	88	68000	9	1360	310
041806	DRF2540	40	25x1,5	189	51,1	6,3	22,4	121,3	12,7	22,9	23	11	16,6	30	100	90000	14	2040	400

MAGNETIC

Reed Switches and Brackets



Find out our
key products



Solution for most applications



Easy and intuitive choice



Excellent value for money



Wide availability



Fast delivery



Features and certifications

The magnetic reed switches are magnetic sensors responding to the presence of a magnetic field. When mounted on a cylinder tube they detect the presence of the magnetic field generated by the magnet set on the piston. This information is used to signal electrical circuits as required. In this chapter is also possible to find cables with M8 connector and brackets for mountings of the magnetic reed switches on the cylinders. The magnetic reed switches are supplied conforming to CE and UKCA standards (series MK supplied according to 2014/34/EU ATEX Directive), the cables are marked cURus, while all products are supplied as standard in compliance with Reach and RoHS Directives.



Series ASV

from page 1.110.10



Series of magnetic reed switches for cylinders, for direct mounting in the suitable housings ("T" grooves) or through brackets.

Series ASC

from page 1.110.30



Series of magnetic reed switches for cylinders, for direct mounting in the suitable housings ("C" grooves).

Series ASH

from page 1.111.1



Series of high-temperatures magnetic reed switches for cylinders, for mounting through brackets.

Series MK

from page 1.113.1



Series of magnetic reed switches for cylinders, according to 2014/34/EU ATEX Directive, for direct mounting in the suitable housings ("T" grooves) or through brackets.

Series CAV

from page 1.115.1



Series of cables with M8 connector, for magnetic reed switch with matching outlet.

Series AFM - AFR - AS..

from page 1.120.1



Series of brackets which allow the mounting on cylinders of the magnetic reed switches type "T".

Matching switches/cylinders

Magnetic switches	Matching with magnetic cylinders																	See page
	MSM MDM MDMA MDMX MDMAX	AMA BMA	AMT BMT AMX	CM	RDM RDMA RDMX RDMAX RXD	CI CIS CS CD	CIX CIXS	DUM	BSM BDM CLS CLD	CLB	GEDB GEDS GPB GPS	GSB GSS	S Ø18	S Ø25+63	CRTH CRTHD CRTF	ARTM..C ARC.. ARP..	PAB PAC PPB PPD PPE PPC	
ASV..	■	● ■	■	■	■	●	■	-	■	●	-	●	■	●	■	-	-	1.110.10
ASC..	-	●	-	-	-	-	-	●	-	-	●	-	-	-	-	●	●	1.110.30
ASH..	-	■	■	■	-	-	-	-	-	-	-	-	-	-	-	-	-	1.111.1
MK500A	■	●	■	■	■	●	■	-	■	●	-	-	-	-	-	-	-	1.113.1
MK502A	■	●	■	■	■	●	■	-	■	●	-	-	-	-	-	-	-	

Key
 ● direct mounting allowed
 ■ mounting through bracket allowed (for matching switches/brackets please see the table below, for matching cylinders/brackets please see the table at page 1.110.4)
 - not allowed matching

Matching switches/accessories

Magnetic switches	Matching with accessories									See page
	AFM..	AFR..	AS101 ÷ AS106 AS110	AS108	AS109	AS112 ÷ AS121	CAV20M8	CAV50M8	CAV1KM8	
ASV1C525	●	●	●	●	●	-	-	-	-	1.110.10
ASV1C550	●	●	●	●	●	-	-	-	-	
ASV1C51K	●	●	●	●	●	-	-	-	-	
ASV1C5M8	●	●	●	●	●	-	●	●	●	
ASV4D225	●	●	●	●	●	-	-	-	-	1.110.11
ASV4D2M8	●	●	●	●	●	-	●	●	●	
ASV7N225	●	●	●	●	●	-	-	-	-	1.110.12
ASV7N2M8	●	●	●	●	●	-	●	●	●	
ASV7M2M8	●	●	●	●	●	-	●	●	●	1.110.13
ASV1H525	●	●	●	●	●	-	-	-	-	
ASC1C525	-	-	-	-	-	-	-	-	-	1.110.30
ASC7N2M8	-	-	-	-	-	-	●	●	●	
ASC7M2M8	-	-	-	-	-	-	●	●	●	1.110.31
ASH6C550	-	-	-	-	-	●	-	-	-	1.111.1
MK500A	●	●	●	●	●	-	-	-	-	1.113.1
MK502A	●	●	●	●	●	-	-	-	-	

Key
 ● allowed matching; - not allowed matching

Matching brackets/cylinders

1 - CYLINDERS

Baskets		Matchig with cylinders														
Item	Code	MSM MDM Ø 8	MSM MDM Ø 10	MSM MDM Ø 12	MSM MDM MDMA MDMX Ø 16	MSM MDM MDMA MDMX Ø 20	MSM MDM MDMA MDMX Ø 25	MSM MDM MDMA RDM RDMX Ø 32+63	CIX CIXS Ø 10+63	AMA* BMA* Ø 32+40	AMA* BMA* Ø 50+63	AMA* BMA* Ø 80	AMA* BMA* Ø 100	AMA* BMA* Ø 125	AMT BMT CM Ø 25+40	AMT BMT CM Ø 50+63
AFM8	072901	●	-	-	-	-	-	-	-	-	-	-	-	-	-	-
AFM10	072902	-	●	-	-	-	-	-	-	-	-	-	-	-	-	-
AFM12	072903	-	-	●	-	-	-	-	-	-	-	-	-	-	-	-
AFM16	072904	-	-	-	●	-	-	-	-	-	-	-	-	-	-	-
AFM20	072905	-	-	-	-	●	-	-	-	-	-	-	-	-	-	-
AFM25	072906	-	-	-	-	-	●	-	-	-	-	-	-	-	-	-
AFR1063	072907	-	-	-	-	-	-	●	●	-	-	-	-	-	-	-
AS101	072908	-	-	-	-	-	-	-	-	●	-	-	-	-	-	-
AS102	072909	-	-	-	-	-	-	-	-	-	●	-	-	-	-	-
AS103	072910	-	-	-	-	-	-	-	-	-	-	●	●	-	-	-
AS104	072911	-	-	-	-	-	-	-	-	-	-	-	-	●	-	-
AS105	072912	-	-	-	-	-	-	-	-	-	-	-	-	-	●	-
AS106	072913	-	-	-	-	-	-	-	-	-	-	-	-	-	-	●
AS108	072915	-	-	-	-	-	-	-	-	-	-	-	-	-	-	-
AS109	072916	-	-	-	-	-	-	-	-	-	-	-	-	-	-	-
AS110	072917	-	-	-	-	-	-	-	-	-	-	-	-	-	-	-
AS112	077838	-	-	-	-	-	-	-	-	-	-	●	-	-	-	-
AS113	077651	-	-	-	-	-	-	-	-	-	●	-	-	-	-	-
AS114	074055	-	-	-	-	-	-	-	-	●	-	-	-	-	-	-
AS115	077839	-	-	-	-	-	-	-	-	-	-	-	●	-	-	-
AS116	074007	-	-	-	-	-	-	-	-	-	-	-	-	●	-	-
AS117	074041	-	-	-	-	-	-	-	-	-	-	-	-	-	●	-
AS118	074043	-	-	-	-	-	-	-	-	-	-	-	-	-	-	●
AS119	074087	-	-	-	-	-	-	-	-	-	-	-	-	-	-	-
AS120	074155	-	-	-	-	-	-	-	-	-	-	-	-	-	-	-
AS121	074169	-	-	-	-	-	-	-	-	-	-	-	-	-	-	-

Key

● allowed matching; - not allowed matching

*Magnetic reed switches can also fit in grooves; **In larger bores the magnetic reed switches fit in grooves.

Magnetic Reed Switches and Brackets

Magnetic reed switches series ASV



Symbol

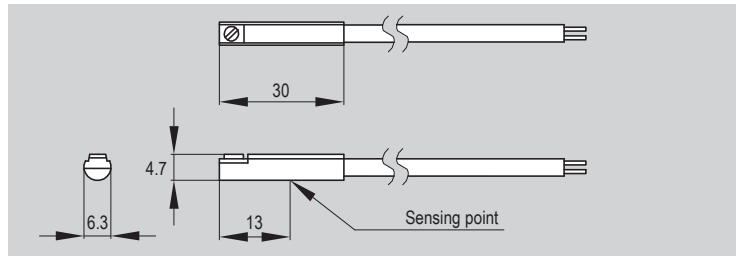
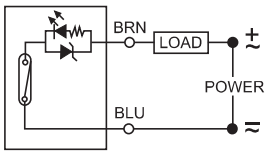

Main features

Code	Item	Description
070946	ASV1C525	Magnetic reed switches for direct mounting in T groove (or through bracket). Reed 2 poles normally open circuit, with flying lead.
071863	ASV1C550	
071864	ASV1C51K	

Technical data

Type	ASV1C525	ASV1C550	ASV1C51K
Circuit	Reed		
Poles	2 poles		
Switching	Normally Open		
Voltage	5+240 V DC/AC		
Switching current	100 mA max		
Contact rating	10 W		
Voltage drop	3,5 V max		
LED	Red		
Electrical connection	Flying lead		
Cable	Gray polyurethane, Ø 3,3		
Cable length	2,5 mt.	5 mt.	10 mt.
Temperature range	-10°C ÷ +70°C		
Protection class	IEC 529 IP67		

Symbol

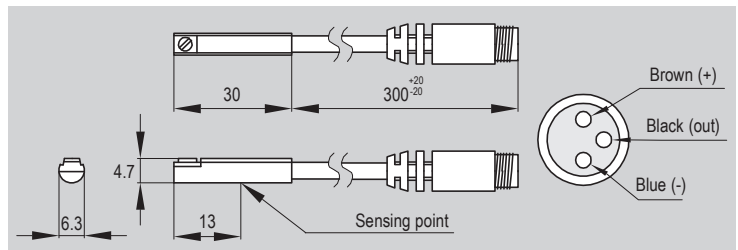
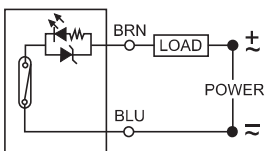

Main features

Code	Item	Description
071189	ASV1C5M8	Magnetic reed switches for direct mounting in T groove (or through bracket). Reed 2 poles normally open circuit, with M8 connector.

Technical data

Type	ASV1C5M8
Circuit	Reed
Poles	2 poles
Switching	Normally Open
Voltage	5+240 V DC/AC
Switching current	100 mA max
Contact rating	10 W
Voltage drop	3,5 V max
LED	Red
Electrical connection	M8 male connector
Cable	Gray polyurethane, Ø 3,3
Cable length	-
Temperature range	-10°C ÷ +70°C
Protection class	IEC 529 IP67

Magnetic Reed Switches and Brackets

Magnetic reed switches series ASV



1 - CYLINDERS

Symbol

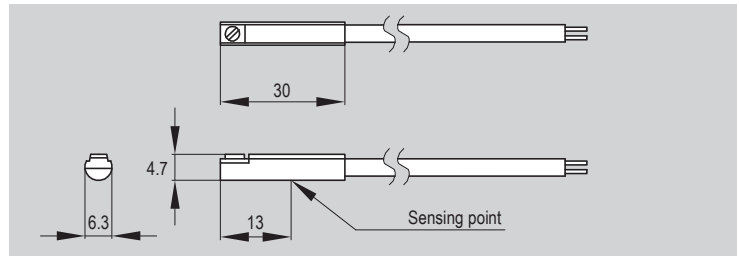
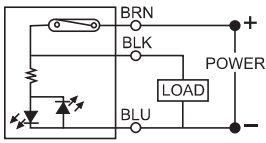

Main features

Code	Item	Description
073639	ASV4D225	Magnetic reed switches for direct mounting in T groove (or through bracket). Reed PNP 3 poles normally open circuit, with flying lead.

Technical data

Type	ASV4D225
Circuit	Reed, PNP
Poles	3 poles
Switching	Normally Open
Voltage	10÷30 V DC
Switching current	500 mA max
Contact rating	10 W @ 100 mA max
Voltage drop	0,1 V max
LED	Yellow
Electrical connection	Flying lead
Cable	Gray polyurethane, Ø 3,3
Cable length	2,5 mt.
Temperature range	-10°C ÷ +70°C
Protection class	IEC 529 IP67

Symbol

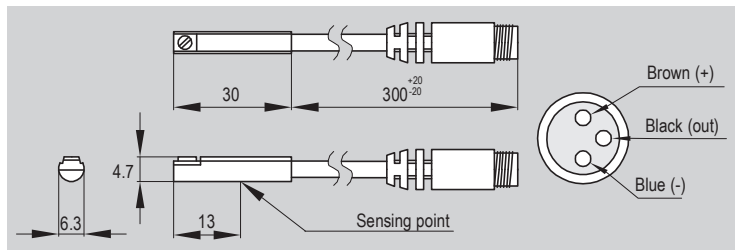
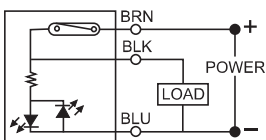

Main features

Code	Item	Description
070246	ASV4D2M8	Magnetic reed switches for direct mounting in T groove (or through bracket). Reed PNP 3 poles normally open circuit, with M8 connector.

Technical data

Type	ASV4D2M8
Circuit	Reed, PNP
Poles	3 poles
Switching	Normally Open
Voltage	10÷30 V DC
Switching current	500 mA max
Contact rating	10 W max
Voltage drop	0,1 V @ 100 mA max
LED	Yellow
Electrical connection	M8 male connector
Cable	Black polyurethane, Ø 3,3
Cable length	-
Temperature range	-10°C ÷ +70°C
Protection class	IEC 529 IP67

Magnetic Reed Switches and Brackets

Magnetic reed switches series ASV



Symbol

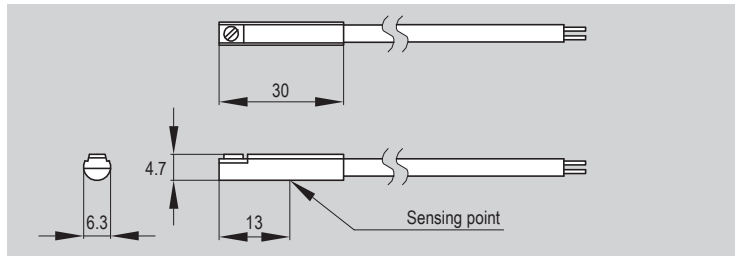
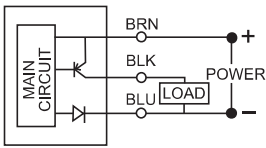

Main features

Code	Item	Description
074900	ASV7N225	Magnetic reed switches for direct mounting in T groove (or through bracket). Reed-Hall PNP 3 poles normally open circuit, with flying lead.

Technical data

Type	ASV7N225
Circuit	Reed-Hall, PNP
Poles	3 poles
Switching	Normally Open solid state output
Voltage	10÷30 V DC
Switching current	200 mA max
Contact rating	6 W max
Voltage drop	1,5 V max
LED	Yellow
Electrical connection	Flying lead
Cable	Gray polyurethane, Ø 3,3
Cable length	2,5 mt.
Temperature range	-10°C ÷ +70°C
Protection class	IEC 529 IP67

Symbol

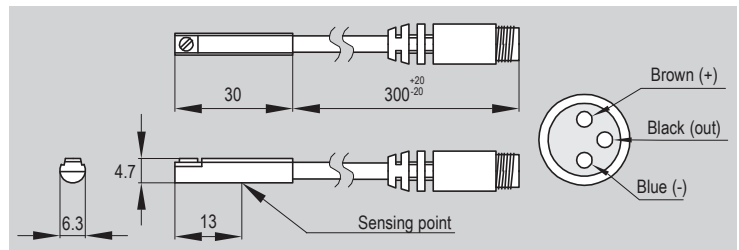
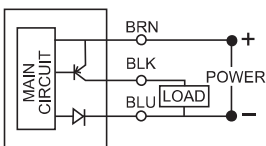

Main features

Code	Item	Description
070247	ASV7N2M8	Magnetic reed switches for direct mounting in T groove (or through bracket). Reed-Hall PNP 3 poles normally open circuit (solid state output), with M8 connector.

Technical data

Type	ASV7N2M8
Circuit	Reed-Hall, PNP
Poles	3 poles
Switching	Normally Open solid state output
Voltage	10÷30 V DC
Switching current	200 mA max
Contact rating	6 W max
Voltage drop	1,5 V max
LED	Yellow
Electrical connection	M8 male connector
Cable	Gray polyurethane, Ø 3,3
Cable length	-
Temperature range	-10°C ÷ +70°C
Protection class	IEC 529 IP67

Magnetic Reed Switches and Brackets

Magnetic reed switches series ASV



1 - CYLINDERS

Symbol

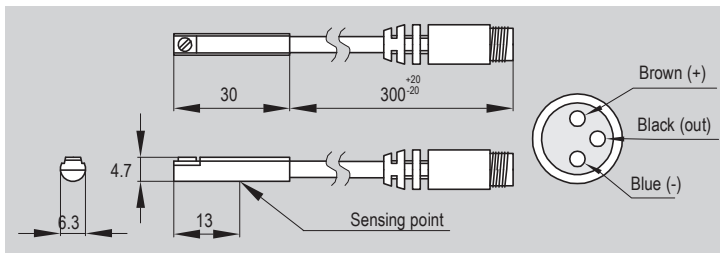
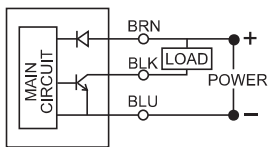

Main features

Code	Item	Description
070372	ASV7M2M8	Magnetic reed switches for direct mounting in T groove (or through bracket). Reed-Hall NPN 3 poles normally open circuit (solid state output), with M8 connector.

Technical data

Type	ASV7M2M8
Circuit	Reed-Hall, NPN
Poles	3 poles
Switching	Normally Open solid state output
Voltage	10÷30 V DC
Switching current	200 mA max
Contact rating	6 W max
Voltage drop	1,5 V max
LED	Red
Electrical connection	M8 male connector
Cable	Gray polyurethane, Ø 3,3
Cable length	-
Temperature range	-10°C ÷ +70°C
Protection class	IEC 529 IP67

Symbol

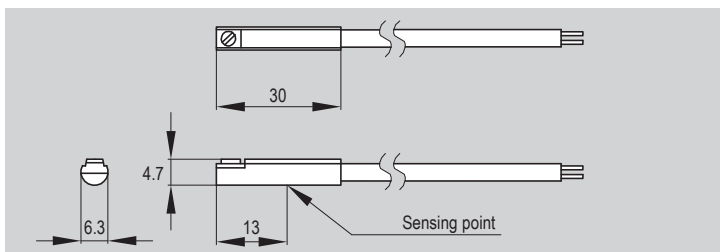
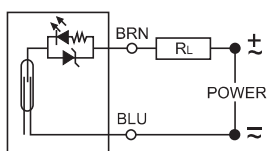

Main features

Code	Item	Description
072918	ASV1H525	Magnetic reed switches for direct mounting in T groove (or through bracket). Reed 2 poles normally closed circuit, with flying lead.

Technical data

Type	ASV1H525
Circuit	Reed
Poles	2 poles
Switching	Normally Closed
Voltage	5÷240 V DC/AC
Switching current	100 mA max
Contact rating	10 W
Voltage drop	3,5 V max
LED	Red
Electrical connection	Flying lead
Cable	Gray polyurethane, Ø 3,3
Cable length	2,5 mt.
Temperature range	-10°C ÷ +70°C
Protection class	IEC 529 IP67

Magnetic Reed Switches and Brackets

Magnetic reed switches series ASC



Symbol

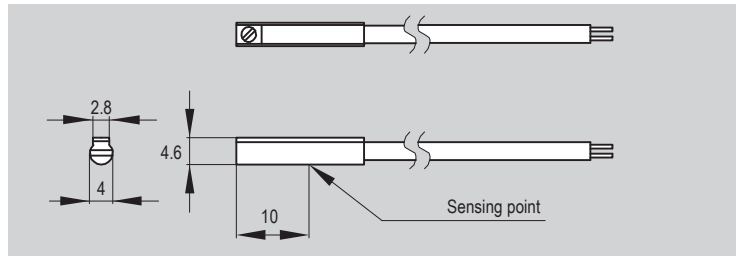
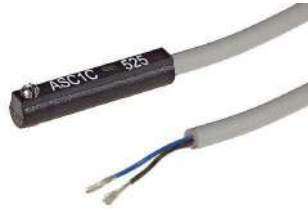
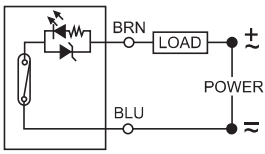

Main features

Code	Item	Description
070248	ASC1C525	Magnetic reed switches for direct mounting in C groove. Reed 2 poles normally open circuit (SPST), with flying lead.

Technical data

Type	ASC1C525
Circuit	Reed
Poles	2 poles
Switching	Normally Open - SPST
Voltage	5÷120 V DC/AC
Switching current	100 mA max
Contact rating	6 W max
Voltage drop	3,5 V max
LED	Red
Electrical connection	Flying lead
Cable	Gray polyurethane, Ø 2,8
Cable length	2,5 mt.
Temperature range	-10°C ÷ +70°C
Protection class	IEC 529 IP67
Electrical protection	-

Symbol

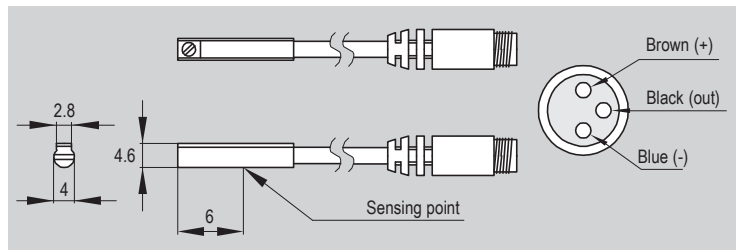
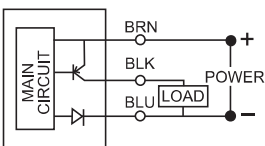

Main features

Code	Item	Description
070249	ASC7N2M8	Magnetic reed switches for direct mounting in C groove. Reed-Hall PNP 3 poles normally open circuit (solid state output), with M8 connector.

Technical data

Type	ASC7N2M8
Circuit	Reed-Hall, PNP
Poles	3 poles
Switching	Normally Open solid state output
Voltage	5÷28 V DC
Switching current	100 mA max
Contact rating	3 W max
Voltage drop	0,5 V max (50 mA)
LED	Green
Electrical connection	M8 male connector
Cable	Black PVC, Ø 2,8
Cable length	-
Temperature range	-10°C ÷ +70°C
Protection class	IEC 529 IP67
Electrical protection	Reverse polarity - Source suppression

Magnetic Reed Switches and Brackets

Magnetic reed switches series ASC



Symbol

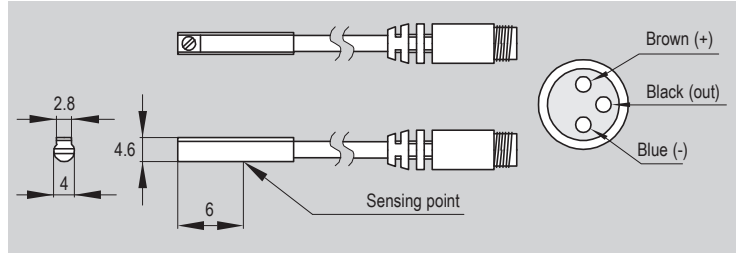
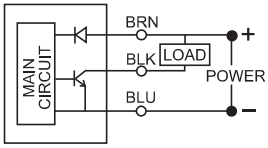

Main features

Code	Item	Description
070382	ASC7M2M8	Magnetic reed switches for direct mounting in C groove. Reed-Hall NPN 3 poles normally open circuit (solid state output), with M8 connector.

Technical data

Type	ASC7M2M8
Circuit	Reed-Hall, NPN
Poles	3 poles
Switching	Normally Open solid state output
Voltage	5÷28 V DC
Switching current	100 mA max
Contact rating	3 W max
Voltage drop	0,5 V max (50 mA)
LED	Red
Electrical connection	M8 male connector
Cable	Black PVC, Ø 2,8
Cable length	-
Temperature range	-10°C ÷ +70°C
Protection class	IEC 529 IP67
Electical protection	Reverse polarity - Source suppression

Magnetic Reed Switches and Brackets

High-temperatures magnetic reed switches series ASH



Symbol

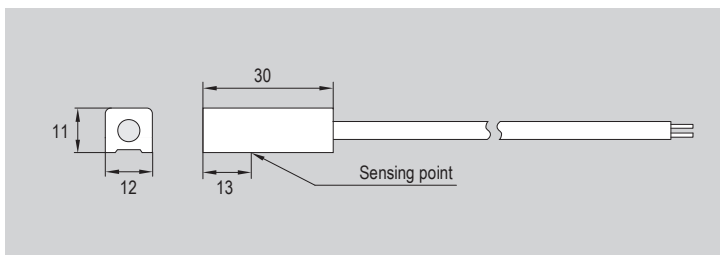
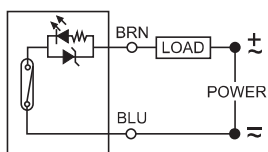

Main features

Code	Item	Description
074047	ASH6C550	High-temperatures magnetic reed switches for mounting through bracket. Reed 2 poles normally open circuit, with flying lead.

Technical data

Type	ASH6C550
Circuit	Reed
Poles	2 poles
Switching	Normally Open
Voltage	5 ÷ 240 V DC/AC
Switching current	500 mA max
Contact rating	10 W
Voltage drop	0,5 V max
Electrical connection	Flying lead
Cable	Black PTFE, Ø 3, 2C
Cable length	5 mt.
Temperature range	-10 °C ÷ +140°C
Protection class	IEC 529 IP67

Magnetic Reed Switches and Brackets

ATEX magnetic reed switches series MK



1 - CYLINDERS

Symbol

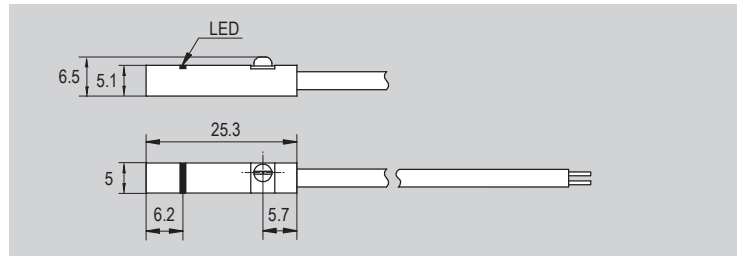
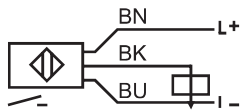

Main features

Code	Item	Description
071120	MK500A	Magnetic reed switches conforming to 2014/34/UE ATEX Directive, for direct mounting in T groove (or through bracket). PNP 3 poles circuit, with reverse polarity protection, short-circuit protection and overload-resistant, with flying lead.

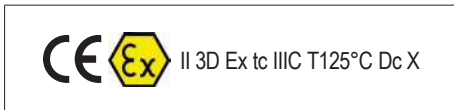

For further information on the ATEX 2014/34/EU Directive, on classifications and protections, see from page III.1

Technical data

Type	MK500A
Electrical design	PNP
Operating voltage	10 ± 30 V DC
Current consumption	≤ 10 mA
Protection class	III
Power-on delay time	< 30 ms
Voltage drop	< 2,5 V
Current rating	100 mA
Switching frequency	10000 Hz
Magnetic sensitivity	2,8 mT
Travel speed	> 10 m/s
Hysteresis	< 1,5 mm
Repeatability	< 0,2 mm
Temperature range	-25°C ÷ +60°C
Protection	IP65 / IP67
LED	Yellow
Cable	Black PVC, Ø 3x0.14mm ²
Cable length	2 mt.
Weight	59,4 g

Symbol

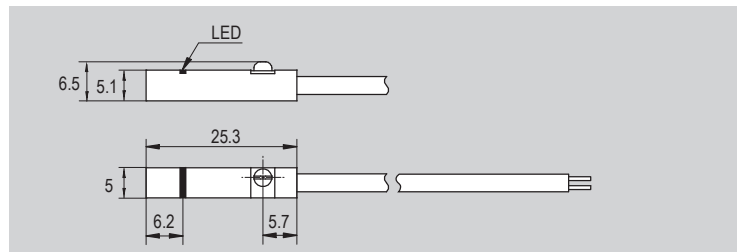
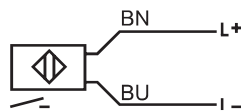

Main features

Code	Item	Description
071108	MK502A	Magnetic reed switches conforming to 2014/34/UE ATEX Directive, for direct mounting in T groove (or through bracket). 2 poles circuit, certified connection to intrinsically safe electrical circuits, with flying lead.

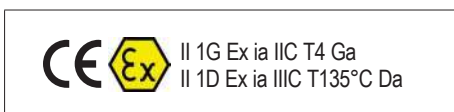

For further information on the ATEX 2014/34/EU Directive, on classifications and protections, see from page III.1

Technical data

Type	MK502A
Electrical design	NAMUR
Operating voltage	8,2 V DC
Current consumption	≥ 2,2 mA
Protection class	III
Switching frequency	2000 Hz
Magnetic sensitivity	2 mT
Travel speed	> 10 m/s
Hysteresis	< 1 mm
Repeatability	< 0,2 mm
Temperature range	-25°C ÷ +70°C
Protection	IP65 / IP67
LED	Yellow
Cable	Blue PVC, Ø 3x0.14mm ²
Cable length	2 mt.
Weight	93,9 g

Magnetic Reed Switches and Brackets

Cables with M8 connector series CAV



Compliance



CAV

Type

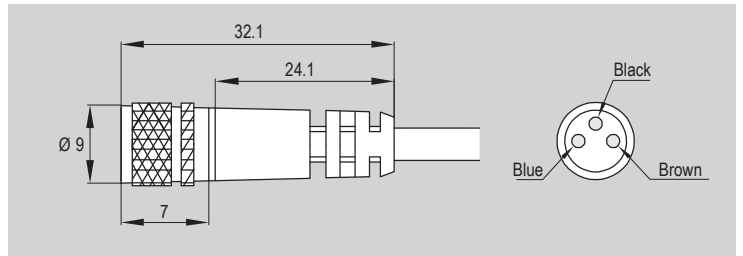

Main features

Code	Item	Description
070269	CAV20M8	Cable, 2 mt. with M8 connector
070250	CAV50M8	Cable, 5 mt. with M8 connector
070298	CAV1KM8	Cable, 10 mt. with M8 connector

Technical data

Type	CAV20M8	CAV50M8	CAV1KM8
Cable	3 x 24 AWG / 0,22 mm ² flexible, spatter resistant, oil resistant		
Cable insulation	300 V		
Cable length	2 mt.	5 mt.	10 mt.
Electrical connection	M8 female connector		
Temperature range	-20°C ÷ +80°C		
Protection class	IP 67		

Materials

Description	Material
Cable	Black PVC
Connector body	Polypropylene
Connector contacts	Gilded brass
Connector nut	Nickel-plated brass

Magnetic Reed Switches and Brackets

Brackets for magnetic reed switches



1 - CYLINDERS

Main features

8 ÷ 25 **AFM**
Bores Ø Type

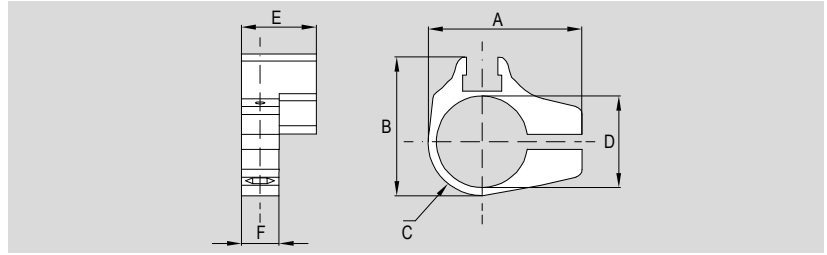

Technical data

Type	Description	Material
AFM..	Locking band for mounting magnetic reed switches type "T" on cylinders ISO 6432 in aluminium and Stainless Steel. Mounting screw included.	Polyamide, aluminium

Dimensions

For cylinder Ø mm	Code	Item	A	B	C	ØD	E	F
8	072901	AFM8	21,4	18,9	6,45	9,3	18	9
10	072902	AFM10	23,4	20,9	7,45	11,3	18	9
12	072903	AFM12	25,4	22,9	8,45	13,3	18	9
16	072904	AFM16	29,4	26,9	10,45	17,3	18	9
20	072905	AFM20	33,4	30,9	12,45	21,3	18	9
25	072906	AFM25	38,4	35,9	14,95	26,3	18	9

Main features

10 ÷ 63 **AFR**
Bores Ø Type

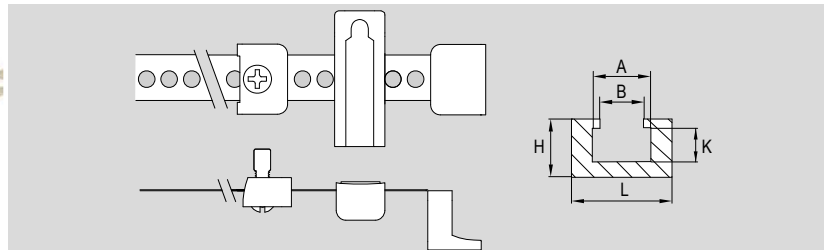

Technical data

Type	Description	Material
AFR..	Locking band for mounting magnetic reed switches type "T" on round cylinders in aluminium or Stainless Steel and on Stainless Steel compact cylinders ISO 21287. Universal metal band, screw and adapter included in kit.	Polyamide, aluminium

Dimensions

For cylinder Ø mm	Code	Item	A	B	H	K	L	Weight (g)
10 ÷ 63	072907	AFR1063	6,5	5,6	8	3,3	10	-

Magnetic Reed Switches and Brackets

Brackets for magnetic reed switches



Main features

12 ÷ 100 **AS108**

Bores Ø Type

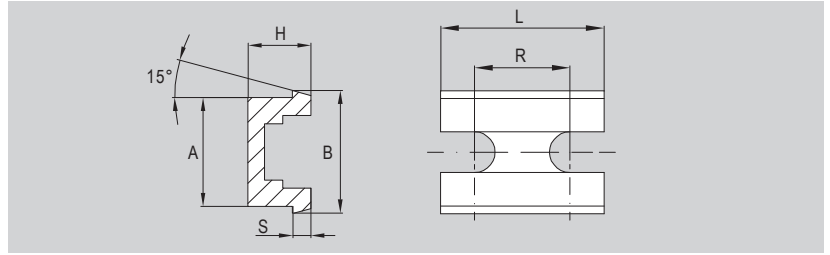

Technical data

Type	Description	Material
AS108	Bracket for mounting magnetic reed switches type "T" on short stroke cylinders.	Polyamide

Dimensions

For cylinder Ø mm	Code	Item	A	B	H	S	L	R
12 ÷ 100	072915	AS108	12	13,5	6,9	2	18	10,5

Main features

18 **AS109**

Bores Ø Type

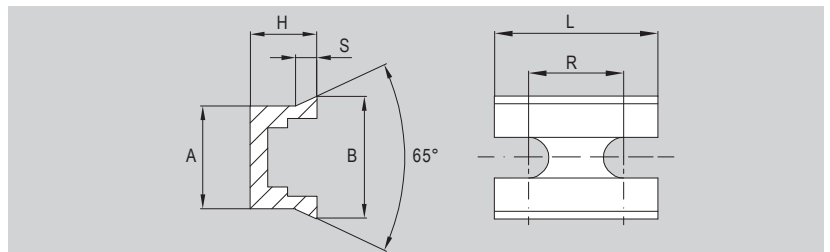

Technical data

Type	Description	Material
AS109	Bracket for mounting magnetic reed switches type "T" on rodless cylinders. In bores larger than Ø 18, the switches fit in grooves .	Polyamide

Dimensions

For cylinder Ø mm	Code	Item	A	B	H	S	L	R
18	072916	AS109	10,1	12,9	6,95	2,2	18	12,5

Magnetic Reed Switches and Brackets

Brackets for magnetic reed switches



Main features

25 ÷ 320

AS..

Bores Ø

Type

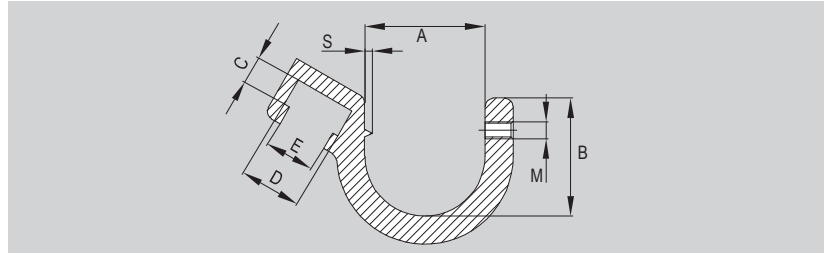

Technical data

Type	Description	Material
AS101 ÷ AS106; AS110	Bracket for mounting magnetic reed switches type "T" on cylinders ISO 15552 , cylinders CNOMO and short stroke cylinders with bores larger than Ø 100. Mounting screw included.	Aluminium

Dimensions

For cylinder type Ø mm					Code	Item	A	B	C	D	E	S	M
AMA BMA	AMT BMT CNOMO	CLSM CLDM	CRTH CRTHD CRTF	AMX									
32 ÷ 40	-	125	40	80 ÷ 100	072908	AS101	11,5	11	3,4	6,7	5,4	0,5	M4
50 ÷ 63	125	160	63	125	072909	AS102	14,5	14	3,4	6,7	5,4	0,5	M4
80 ÷ 100	160 ÷ 200	200	80	160 ÷ 200	072910	AS103	16,5	20	3,4	6,7	5,4	0,5	M4
125	-	250	-	-	072911	AS104	17,5	24	3,4	6,7	5,4	0,5	M4
-	25 ÷ 40	-	-	32 ÷ 40	072912	AS105	7	8	3,4	6,7	5,4	0,5	M4
-	50 ÷ 100	-	-	50 ÷ 63	072913	AS106	10	14	3,4	6,7	5,4	0,5	M4
-	250 ÷ 320	-	-	-	072917	AS110	24,5	21	3,4	6,7	5,4	0,5	M4

Main features

8 ÷ 10

Strokes mm

DR

Type



12,5 ÷ 40

Strokes mm

DRF

Type



Technical data

Type	DR	DRF
Description	Adjustable hydraulic shock absorbers without mechanical stopper	Adjustable hydraulic shock absorbers with mechanical stopper included
Temperature range	+5°C ÷ +70°C	+12°C ÷ +90°C
Strokes	8 - 10 mm	12,5 - 19,1 - 25,4 - 40 mm
Maximum impact speed	4 m/s	

Dimensions

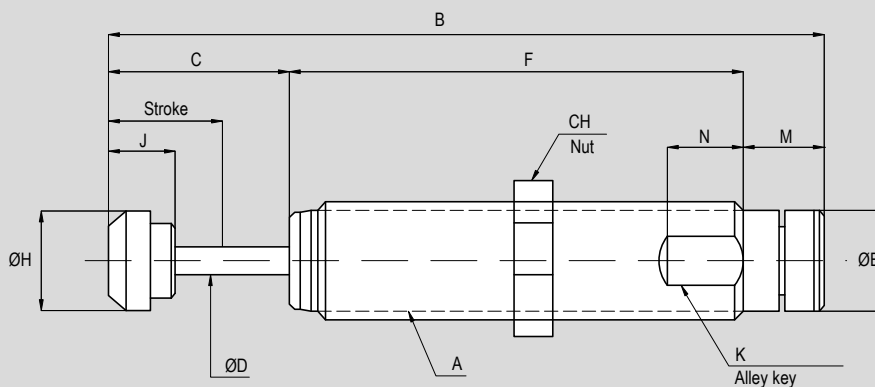

Code	Item	Stroke	A (thread)	B	C	ØD	ØE	F	N	ØH	K	J	M	CH	Maximum absorbing capacity (Nm)		Efficiency measurement		Weight (g)
															Per cycle (W ₃)	Per hour (W ₄)	min. (Kg.)	max. (Kg.)	
041801	DR1008	8	10x1	66,5	14,5	2,5	8,8	40	-	6	-	6,5	12	13	1,8	3600	0,2	10	26
041802	DR1210	10	12x1	84	18	3,5	10,8	60	-	8	-	8	6	14	4	6000	0,9	57	43
041803	DRF1412	12,5	14x1,5	87	17,5	8	12	61	12	12	12	10	8,5	17	17	35000	0,6	90	60
041804	DRF2019	19,1	20x1,5	117,9	30	4,8	16,8	74,7	12,7	16,8	18	11	13,2	24	25	45000	2,3	226	130
041805	DRF2525	25,4	25x1,5	142,6	36,3	6,3	22,4	89,7	12,7	22,9	23	11	16,6	30	88	68000	9	1360	310
041806	DRF2540	40	25x1,5	189	51,1	6,3	22,4	121,3	12,7	22,9	23	11	16,6	30	100	90000	14	2040	400

MAGNETIC

Reed Switches and Brackets



Find out our
key products



Solution for most applications



Easy and intuitive choice



Excellent value for money



Wide availability



Fast delivery



Features and certifications

The magnetic reed switches are magnetic sensors responding to the presence of a magnetic field. When mounted on a cylinder tube they detect the presence of the magnetic field generated by the magnet set on the piston. This information is used to signal electrical circuits as required.

In this chapter is also possible to find cables with M8 connector and brackets for mountings of the magnetic reed switches on the cylinders.

The magnetic reed switches are supplied conforming to CE and UKCA standards (series MK supplied according to 2014/34/EU ATEX Directive), the cables are marked cURus, while all products are supplied as standard in compliance with Reach and RoHS Directives.



Series ASV

from page 1.110.10



Series of magnetic reed switches for cylinders, for direct mounting in the suitable housings ("T" grooves) or through brackets.

Series ASC

from page 1.110.30



Series of magnetic reed switches for cylinders, for direct mounting in the suitable housings ("C" grooves).

Series ASH

from page 1.111.1



Series of high-temperatures magnetic reed switches for cylinders, for mounting through brackets.

Series MK

from page 1.113.1



Series of magnetic reed switches for cylinders, according to 2014/34/EU ATEX Directive, for direct mounting in the suitable housings ("T" grooves) or through brackets.

Series CAV

from page 1.115.1



Series of cables with M8 connector, for magnetic reed switch with matching outlet.

Series AFM - AFR - AS..

from page 1.120.1



Series of brackets which allow the mounting on cylinders of the magnetic reed switches type "T".

Matching switches/cylinders

Magnetic switches	Matching with magnetic cylinders																	See page
	MSM MDM MDMA MDMX MDMAX	AMA BMA	AMT BMT AMX	CM	RDM RDMA RDMX RDMAX RXD	CI CIS CS CD	CIX CIXS	DUM	BSM BDM CLS CLD	CLB	GEDB GEDS GPB GPS	GSB GSS	S Ø18	S Ø25+63	CRTH CRTHD CRTF	ARTM..C ARC.. ARP..	PAB PAC PPB PPD PPE PPC	
ASV..	■	● ■	■	■	■	●	■	-	■	●	-	●	■	●	■	-	-	1.110.10
ASC..	-	●	-	-	-	-	-	●	-	-	●	-	-	-	-	●	●	1.110.30
ASH..	-	■	■	■	-	-	-	-	-	-	-	-	-	-	-	-	-	1.111.1
MK500A	■	●	■	■	■	●	■	-	■	●	-	-	-	-	-	-	-	1.113.1
MK502A	■	●	■	■	■	●	■	-	■	●	-	-	-	-	-	-	-	

Key
 ● direct mounting allowed
 ■ mounting through bracket allowed (for matching switches/brackets please see the table below, for matching cylinders/brackets please see the table at page 1.110.4)
 - not allowed matching

Matching switches/accessories

Magnetic switches	Matching with accessories									See page
	AFM..	AFR..	AS101 ÷ AS106 AS110	AS108	AS109	AS112 ÷ AS121	CAV20M8	CAV50M8	CAV1KM8	
ASV1C525	●	●	●	●	●	-	-	-	-	1.110.10
ASV1C550	●	●	●	●	●	-	-	-	-	
ASV1C51K	●	●	●	●	●	-	-	-	-	
ASV1C5M8	●	●	●	●	●	-	●	●	●	
ASV4D225	●	●	●	●	●	-	-	-	-	1.110.11
ASV4D2M8	●	●	●	●	●	-	●	●	●	
ASV7N225	●	●	●	●	●	-	-	-	-	1.110.12
ASV7N2M8	●	●	●	●	●	-	●	●	●	
ASV7M2M8	●	●	●	●	●	-	●	●	●	1.110.13
ASV1H525	●	●	●	●	●	-	-	-	-	
ASC1C525	-	-	-	-	-	-	-	-	-	1.110.30
ASC7N2M8	-	-	-	-	-	-	●	●	●	
ASC7M2M8	-	-	-	-	-	-	●	●	●	1.110.31
ASH6C550	-	-	-	-	-	●	-	-	-	1.111.1
MK500A	●	●	●	●	●	-	-	-	-	1.113.1
MK502A	●	●	●	●	●	-	-	-	-	

Key
 ● allowed matching; - not allowed matching

Matching brackets/cylinders

1 - CYLINDERS

Baskets		Matchig with cylinders														
Item	Code	MSM MDM Ø 8	MSM MDM Ø 10	MSM MDM Ø 12	MSM MDM MDMA MDMX Ø 16	MSM MDM MDMA MDMX Ø 20	MSM MDM MDMA MDMX Ø 25	MSM MDM MDMA RDM RDMX Ø 32+63	CIX CIXS Ø 10+63	AMA* BMA* Ø 32+40	AMA* BMA* Ø 50+63	AMA* BMA* Ø 80	AMA* BMA* Ø 100	AMA* BMA* Ø 125	AMT BMT CM Ø 25+40	AMT BMT CM Ø 50+63
AFM8	072901	●	-	-	-	-	-	-	-	-	-	-	-	-	-	-
AFM10	072902	-	●	-	-	-	-	-	-	-	-	-	-	-	-	-
AFM12	072903	-	-	●	-	-	-	-	-	-	-	-	-	-	-	-
AFM16	072904	-	-	-	●	-	-	-	-	-	-	-	-	-	-	-
AFM20	072905	-	-	-	-	●	-	-	-	-	-	-	-	-	-	-
AFM25	072906	-	-	-	-	-	●	-	-	-	-	-	-	-	-	-
AFR1063	072907	-	-	-	-	-	-	●	●	-	-	-	-	-	-	-
AS101	072908	-	-	-	-	-	-	-	-	●	-	-	-	-	-	-
AS102	072909	-	-	-	-	-	-	-	-	-	●	-	-	-	-	-
AS103	072910	-	-	-	-	-	-	-	-	-	-	●	●	-	-	-
AS104	072911	-	-	-	-	-	-	-	-	-	-	-	-	●	-	-
AS105	072912	-	-	-	-	-	-	-	-	-	-	-	-	-	●	-
AS106	072913	-	-	-	-	-	-	-	-	-	-	-	-	-	-	●
AS108	072915	-	-	-	-	-	-	-	-	-	-	-	-	-	-	-
AS109	072916	-	-	-	-	-	-	-	-	-	-	-	-	-	-	-
AS110	072917	-	-	-	-	-	-	-	-	-	-	-	-	-	-	-
AS112	077838	-	-	-	-	-	-	-	-	-	-	●	-	-	-	-
AS113	077651	-	-	-	-	-	-	-	-	-	●	-	-	-	-	-
AS114	074055	-	-	-	-	-	-	-	-	●	-	-	-	-	-	-
AS115	077839	-	-	-	-	-	-	-	-	-	-	-	●	-	-	-
AS116	074007	-	-	-	-	-	-	-	-	-	-	-	-	●	-	-
AS117	074041	-	-	-	-	-	-	-	-	-	-	-	-	-	●	-
AS118	074043	-	-	-	-	-	-	-	-	-	-	-	-	-	-	●
AS119	074087	-	-	-	-	-	-	-	-	-	-	-	-	-	-	-
AS120	074155	-	-	-	-	-	-	-	-	-	-	-	-	-	-	-
AS121	074169	-	-	-	-	-	-	-	-	-	-	-	-	-	-	-

Key

● allowed matching; - not allowed matching

*Magnetic reed switches can also fit in grooves; **In larger bores the magnetic reed switches fit in grooves.

Matchig with cylinders

AMT BMT CM Ø 80+100	AMT BMT CM Ø 125	AMT BMT CM Ø 160+200	AMT BMT Ø 250+320	AMX Ø 32+40	AMX Ø 50+63	AMX Ø 80+100	AMX Ø 125	AMX Ø 160+200	BSM BDM Ø 12+100	CLS CLD Ø 125	CLS CLD Ø 160	CLS CLD Ø 200	CLD Ø 250	S Ø 18**	CRTH CRTHD CRTF Ø 40	CRTH CRTHD CRTF Ø 63	CRTH CRTHD CRTF Ø 80
-	-	-	-	-	-	-	-	-	-	-	-	-	-	-	-	-	-
-	-	-	-	-	-	-	-	-	-	-	-	-	-	-	-	-	-
-	-	-	-	-	-	-	-	-	-	-	-	-	-	-	-	-	-
-	-	-	-	-	-	-	-	-	-	-	-	-	-	-	-	-	-
-	-	-	-	-	-	-	-	-	-	-	-	-	-	-	-	-	-
-	-	-	-	-	-	-	-	-	-	-	-	-	-	-	-	-	-
-	-	-	-	-	-	-	-	-	-	-	-	-	-	-	-	-	-
-	-	-	-	-	-	•	-	-	-	•	-	-	-	-	•	-	-
-	•	-	-	-	-	-	•	-	-	-	•	-	-	-	-	•	-
-	-	•	-	-	-	-	-	•	-	-	-	•	-	-	-	-	•
-	-	-	-	-	-	-	-	-	-	-	-	-	•	-	-	-	-
-	-	-	-	•	-	-	-	-	-	-	-	-	-	-	-	-	-
•	-	-	-	-	•	-	-	-	-	-	-	-	-	-	-	-	-
-	-	-	-	-	-	-	-	-	•	-	-	-	-	-	-	-	-
-	-	-	-	-	-	-	-	-	-	-	-	-	-	•	-	-	-
-	-	-	-	-	-	-	-	-	-	-	-	-	-	-	-	-	-
-	-	-	-	-	-	-	-	-	-	-	-	-	-	-	-	-	-
-	-	-	-	-	-	-	-	-	-	-	-	-	-	-	-	-	-
-	-	-	-	-	-	-	-	-	-	-	-	-	-	-	-	-	-
-	-	-	-	-	-	-	-	-	-	-	-	-	-	-	-	-	-
-	-	-	-	-	-	-	-	-	-	-	-	-	-	-	-	-	-
-	-	-	-	-	-	-	-	-	-	-	-	-	-	-	-	-	-
-	-	-	-	-	-	-	-	-	-	-	-	-	-	-	-	-	-
-	-	-	-	-	-	-	-	-	-	-	-	-	-	-	-	-	-
-	-	-	-	-	-	-	-	-	-	-	-	-	-	-	-	-	-
-	-	-	-	-	-	-	-	-	-	-	-	-	-	-	-	-	-
-	-	-	-	-	-	-	-	-	-	-	-	-	-	-	-	-	-
•	-	-	-	-	-	•	-	-	-	-	-	-	-	-	-	-	-
-	•	-	-	-	-	-	•	-	-	-	-	-	-	-	-	-	-
-	-	•	-	-	-	-	-	•	-	-	-	-	-	-	-	-	-

1 - CYLINDERS

Magnetic Reed Switches and Brackets

Magnetic reed switches series ASV



Symbol

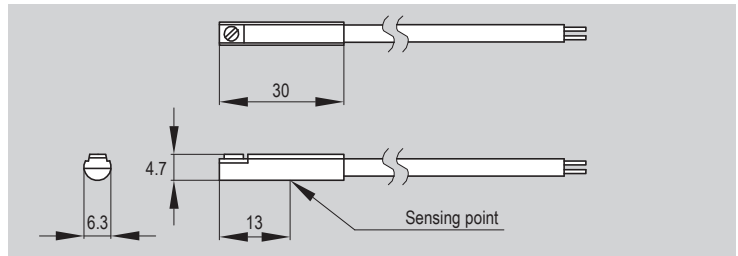
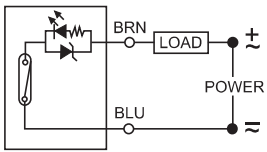

Main features

Code	Item	Description
070946	ASV1C525	Magnetic reed switches for direct mounting in T groove (or through bracket). Reed 2 poles normally open circuit, with flying lead.
071863	ASV1C550	
071864	ASV1C51K	

Technical data

Type	ASV1C525	ASV1C550	ASV1C51K
Circuit	Reed		
Poles	2 poles		
Switching	Normally Open		
Voltage	5+240 V DC/AC		
Switching current	100 mA max		
Contact rating	10 W		
Voltage drop	3,5 V max		
LED	Red		
Electrical connection	Flying lead		
Cable	Gray polyurethane, Ø 3,3		
Cable length	2,5 mt.	5 mt.	10 mt.
Temperature range	-10°C ÷ +70°C		
Protection class	IEC 529 IP67		

Symbol

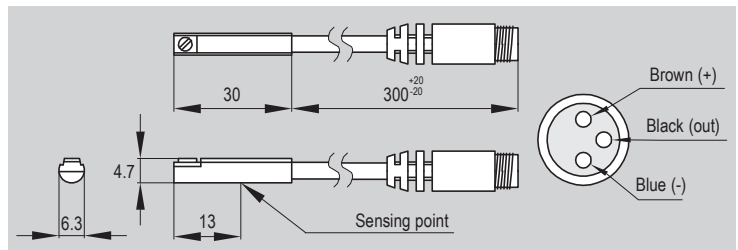
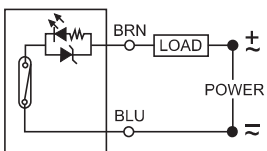

Main features

Code	Item	Description
071189	ASV1C5M8	Magnetic reed switches for direct mounting in T groove (or through bracket). Reed 2 poles normally open circuit, with M8 connector.

Technical data

Type	ASV1C5M8
Circuit	Reed
Poles	2 poles
Switching	Normally Open
Voltage	5+240 V DC/AC
Switching current	100 mA max
Contact rating	10 W
Voltage drop	3,5 V max
LED	Red
Electrical connection	M8 male connector
Cable	Gray polyurethane, Ø 3,3
Cable length	-
Temperature range	-10°C ÷ +70°C
Protection class	IEC 529 IP67

Magnetic Reed Switches and Brackets

Magnetic reed switches series ASV



1 - CYLINDERS

Symbol

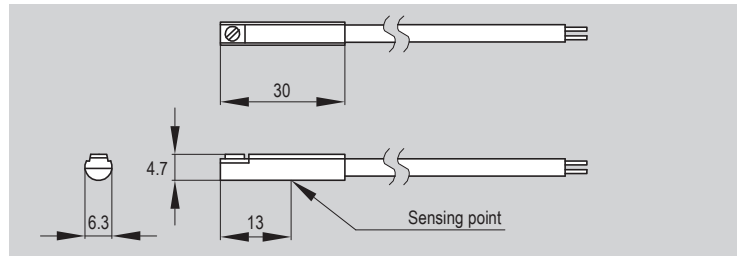
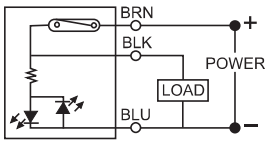

Main features

Code	Item	Description
073639	ASV4D225	Magnetic reed switches for direct mounting in T groove (or through bracket). Reed PNP 3 poles normally open circuit, with flying lead.

Technical data

Type	ASV4D225
Circuit	Reed, PNP
Poles	3 poles
Switching	Normally Open
Voltage	10÷30 V DC
Switching current	500 mA max
Contact rating	10 W @ 100 mA max
Voltage drop	0,1 V max
LED	Yellow
Electrical connection	Flying lead
Cable	Gray polyurethane, Ø 3,3
Cable length	2,5 mt.
Temperature range	-10°C ÷ +70°C
Protection class	IEC 529 IP67

Symbol

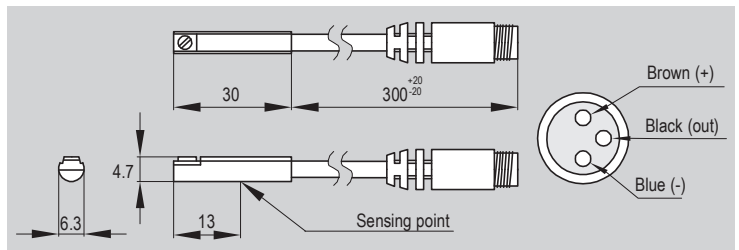
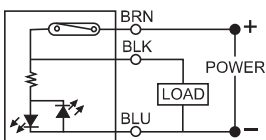

Main features

Code	Item	Description
070246	ASV4D2M8	Magnetic reed switches for direct mounting in T groove (or through bracket). Reed PNP 3 poles normally open circuit, with M8 connector.

Technical data

Type	ASV4D2M8
Circuit	Reed, PNP
Poles	3 poles
Switching	Normally Open
Voltage	10÷30 V DC
Switching current	500 mA max
Contact rating	10 W max
Voltage drop	0,1 V @ 100 mA max
LED	Yellow
Electrical connection	M8 male connector
Cable	Black polyurethane, Ø 3,3
Cable length	-
Temperature range	-10°C ÷ +70°C
Protection class	IEC 529 IP67

Magnetic Reed Switches and Brackets

Magnetic reed switches series ASV



Symbol

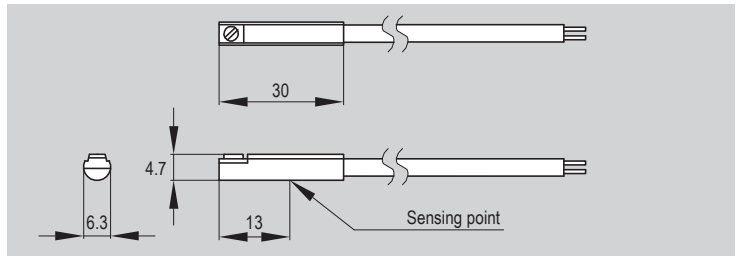
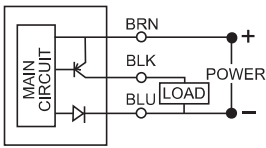

Main features

Code	Item	Description
074900	ASV7N225	Magnetic reed switches for direct mounting in T groove (or through bracket). Reed-Hall PNP 3 poles normally open circuit, with flying lead.

Technical data

Type	ASV7N225
Circuit	Reed-Hall, PNP
Poles	3 poles
Switching	Normally Open solid state output
Voltage	10÷30 V DC
Switching current	200 mA max
Contact rating	6 W max
Voltage drop	1,5 V max
LED	Yellow
Electrical connection	Flying lead
Cable	Gray polyurethane, Ø 3,3
Cable length	2,5 mt.
Temperature range	-10°C ÷ +70°C
Protection class	IEC 529 IP67

Symbol

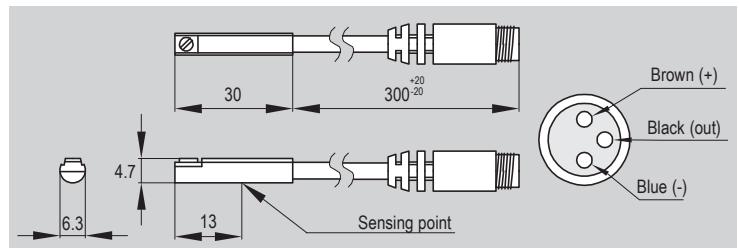
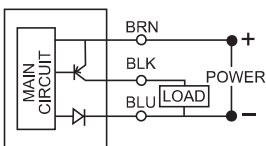

Main features

Code	Item	Description
070247	ASV7N2M8	Magnetic reed switches for direct mounting in T groove (or through bracket). Reed-Hall PNP 3 poles normally open circuit (solid state output), with M8 connector.

Technical data

Type	ASV7N2M8
Circuit	Reed-Hall, PNP
Poles	3 poles
Switching	Normally Open solid state output
Voltage	10÷30 V DC
Switching current	200 mA max
Contact rating	6 W max
Voltage drop	1,5 V max
LED	Yellow
Electrical connection	M8 male connector
Cable	Gray polyurethane, Ø 3,3
Cable length	-
Temperature range	-10°C ÷ +70°C
Protection class	IEC 529 IP67

Magnetic Reed Switches and Brackets

Magnetic reed switches series ASV



1 - CYLINDERS

Symbol

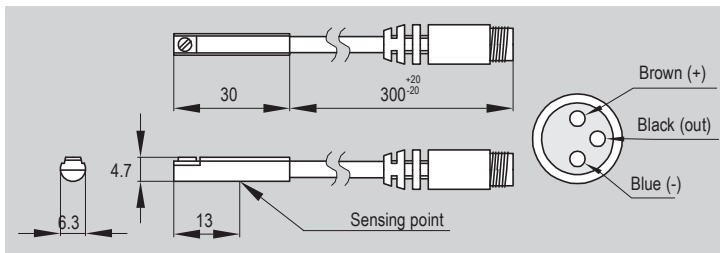
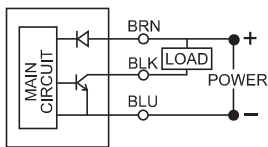

Main features

Code	Item	Description
070372	ASV7M2M8	Magnetic reed switches for direct mounting in T groove (or through bracket). Reed-Hall NPN 3 poles normally open circuit (solid state output), with M8 connector.

Technical data

Type	ASV7M2M8
Circuit	Reed-Hall, NPN
Poles	3 poles
Switching	Normally Open solid state output
Voltage	10÷30 V DC
Switching current	200 mA max
Contact rating	6 W max
Voltage drop	1,5 V max
LED	Red
Electrical connection	M8 male connector
Cable	Gray polyurethane, Ø 3,3
Cable length	-
Temperature range	-10°C ÷ +70°C
Protection class	IEC 529 IP67

Symbol

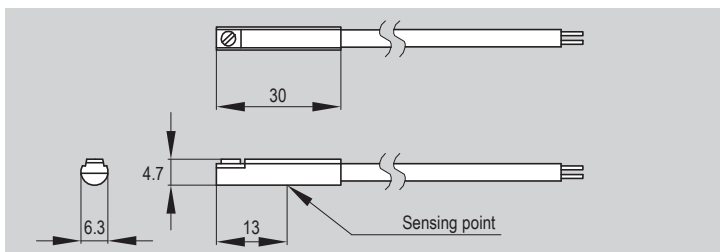
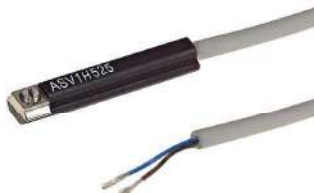
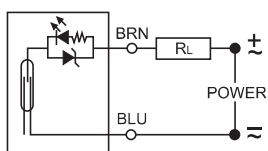

Main features

Code	Item	Description
072918	ASV1H525	Magnetic reed switches for direct mounting in T groove (or through bracket). Reed 2 poles normally closed circuit, with flying lead.

Technical data

Type	ASV1H525
Circuit	Reed
Poles	2 poles
Switching	Normally Closed
Voltage	5÷240 V DC/AC
Switching current	100 mA max
Contact rating	10 W
Voltage drop	3,5 V max
LED	Red
Electrical connection	Flying lead
Cable	Gray polyurethane, Ø 3,3
Cable length	2,5 mt.
Temperature range	-10°C ÷ +70°C
Protection class	IEC 529 IP67

Magnetic Reed Switches and Brackets

Magnetic reed switches series ASC



Symbol

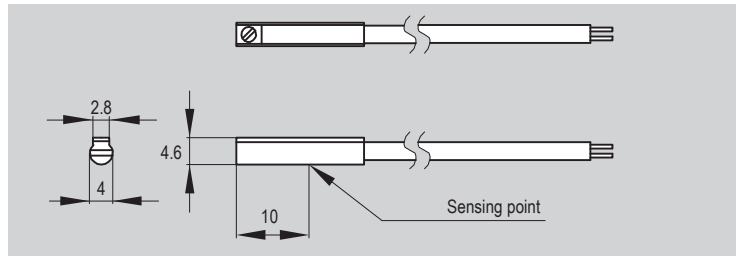
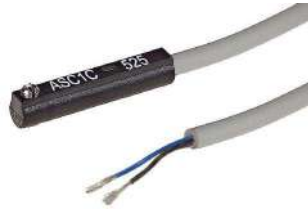
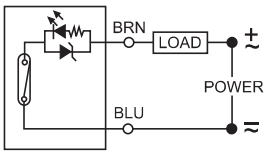

Main features

Code	Item	Description
070248	ASC1C525	Magnetic reed switches for direct mounting in C groove. Reed 2 poles normally open circuit (SPST), with flying lead.

Technical data

Type	ASC1C525
Circuit	Reed
Poles	2 poles
Switching	Normally Open - SPST
Voltage	5÷120 V DC/AC
Switching current	100 mA max
Contact rating	6 W max
Voltage drop	3,5 V max
LED	Red
Electrical connection	Flying lead
Cable	Gray polyurethane, Ø 2,8
Cable length	2,5 mt.
Temperature range	-10°C ÷ +70°C
Protection class	IEC 529 IP67
Electrical protection	-

Symbol

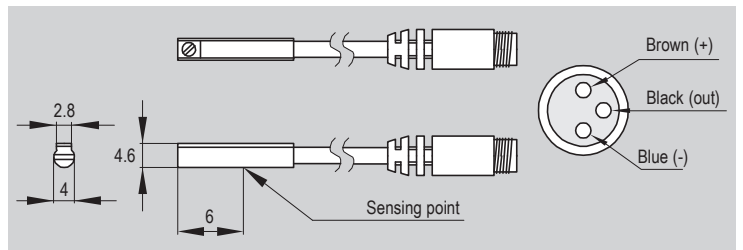
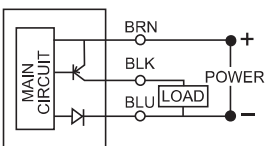

Main features

Code	Item	Description
070249	ASC7N2M8	Magnetic reed switches for direct mounting in C groove. Reed-Hall PNP 3 poles normally open circuit (solid state output), with M8 connector.

Technical data

Type	ASC7N2M8
Circuit	Reed-Hall, PNP
Poles	3 poles
Switching	Normally Open solid state output
Voltage	5÷28 V DC
Switching current	100 mA max
Contact rating	3 W max
Voltage drop	0,5 V max (50 mA)
LED	Green
Electrical connection	M8 male connector
Cable	Black PVC, Ø 2,8
Cable length	-
Temperature range	-10°C ÷ +70°C
Protection class	IEC 529 IP67
Electrical protection	Reverse polarity - Source suppression

Magnetic Reed Switches and Brackets

Magnetic reed switches series ASC



Symbol

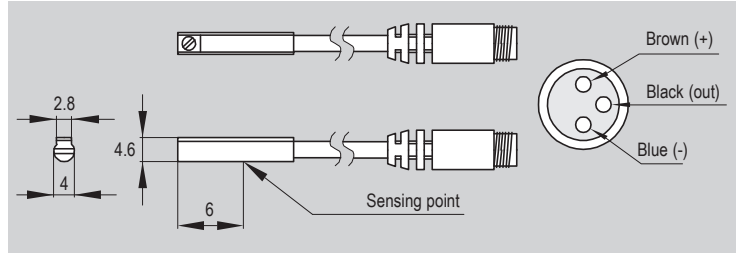
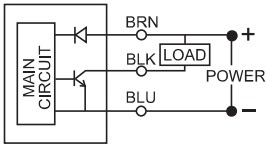

Main features

Code	Item	Description
070382	ASC7M2M8	Magnetic reed switches for direct mounting in C groove. Reed-Hall NPN 3 poles normally open circuit (solid state output), with M8 connector.

Technical data

Type	ASC7M2M8
Circuit	Reed-Hall, NPN
Poles	3 poles
Switching	Normally Open solid state output
Voltage	5÷28 V DC
Switching current	100 mA max
Contact rating	3 W max
Voltage drop	0,5 V max (50 mA)
LED	Red
Electrical connection	M8 male connector
Cable	Black PVC, Ø 2,8
Cable length	-
Temperature range	-10°C ÷ +70°C
Protection class	IEC 529 IP67
Electical protection	Reverse polarity - Source suppression

Magnetic Reed Switches and Brackets

High-temperatures magnetic reed switches series ASH



Symbol

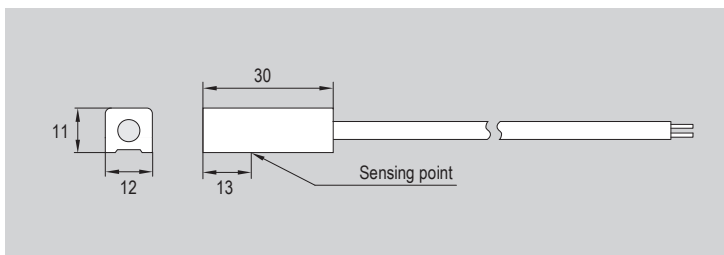
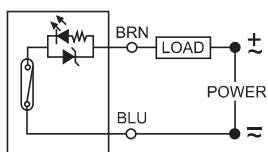

Main features

Code	Item	Description
074047	ASH6C550	High-temperatures magnetic reed switches for mounting through bracket. Reed 2 poles normally open circuit, with flying lead.

Technical data

Type	ASH6C550
Circuit	Reed
Poles	2 poles
Switching	Normally Open
Voltage	5 ÷ 240 V DC/AC
Switching current	500 mA max
Contact rating	10 W
Voltage drop	0,5 V max
Electrical connection	Flying lead
Cable	Black PTFE, Ø 3, 2C
Cable length	5 mt.
Temperature range	-10 °C ÷ +140°C
Protection class	IEC 529 IP67

Magnetic Reed Switches and Brackets

ATEX magnetic reed switches series MK



1 - CYLINDERS

Symbol

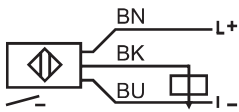

Main features

Code	Item	Description
071120	MK500A	Magnetic reed switches conforming to 2014/34/UE ATEX Directive, for direct mounting in T groove (or through bracket). PNP 3 poles circuit, with reverse polarity protection, short-circuit protection and overload-resistant, with flying lead.

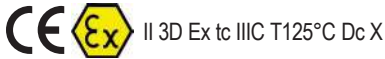

For further information on the ATEX 2014/34/EU Directive, on classifications and protections, see from page III.1

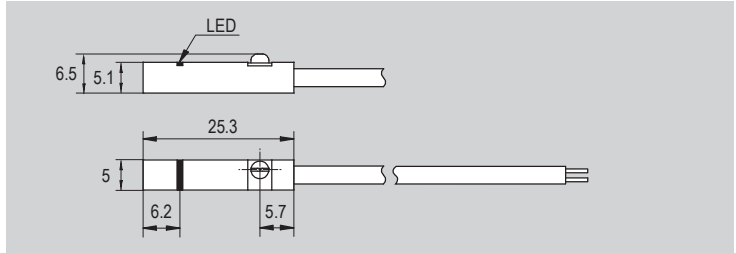

Technical data

Type	MK500A
Electrical design	PNP
Operating voltage	10 ± 30 V DC
Current consumption	≤ 10 mA
Protection class	III
Power-on delay time	< 30 ms
Voltage drop	< 2,5 V
Current rating	100 mA
Switching frequency	10000 Hz
Magnetic sensitivity	2,8 mT
Travel speed	> 10 m/s
Hysteresis	< 1,5 mm
Repeatability	< 0,2 mm
Temperature range	-25°C ÷ +60°C
Protection	IP65 / IP67
LED	Yellow
Cable	Black PVC, Ø 3x0.14mm ²
Cable length	2 mt.
Weight	59,4 g

Symbol

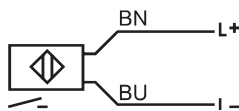

Main features

Code	Item	Description
071108	MK502A	Magnetic reed switches conforming to 2014/34/UE ATEX Directive, for direct mounting in T groove (or through bracket). 2 poles circuit, certified connection to intrinsically safe electrical circuits, with flying lead.

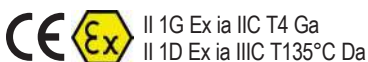

For further information on the ATEX 2014/34/EU Directive, on classifications and protections, see from page III.1

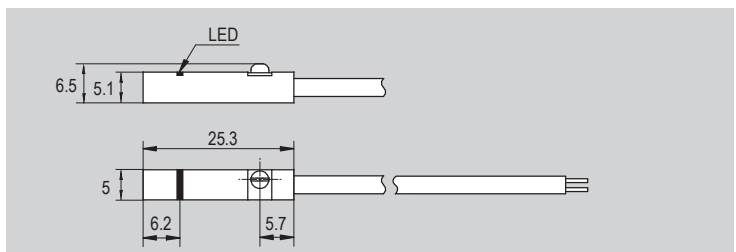

Technical data

Type	MK502A
Electrical design	NAMUR
Operating voltage	8,2 V DC
Current consumption	≥ 2,2 mA
Protection class	III
Switching frequency	2000 Hz
Magnetic sensitivity	2 mT
Travel speed	> 10 m/s
Hysteresis	< 1 mm
Repeatability	< 0,2 mm
Temperature range	-25°C ÷ +70°C
Protection	IP65 / IP67
LED	Yellow
Cable	Blue PVC, Ø 3x0.14mm ²
Cable length	2 mt.
Weight	93,9 g

Magnetic Reed Switches and Brackets

Cables with M8 connector series CAV



Compliance



CAV

Type

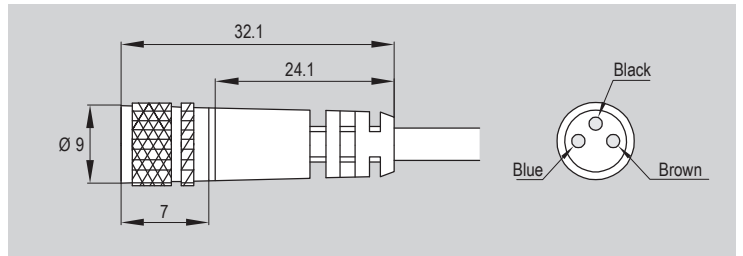

Main features

Code	Item	Description
070269	CAV20M8	Cable, 2 mt. with M8 connector
070250	CAV50M8	Cable, 5 mt. with M8 connector
070298	CAV1KM8	Cable, 10 mt. with M8 connector

Technical data

Type	CAV20M8	CAV50M8	CAV1KM8
Cable	3 x 24 AWG / 0,22 mm ² flexible, spatter resistant, oil resistant		
Cable insulation	300 V		
Cable length	2 mt.	5 mt.	10 mt.
Electrical connection	M8 female connector		
Temperature range	-20°C ÷ +80°C		
Protection class	IP 67		

Materials

Description	Material
Cable	Black PVC
Connector body	Polypropylene
Connector contacts	Gilded brass
Connector nut	Nickel-plated brass

Magnetic Reed Switches and Brackets

Brackets for magnetic reed switches



1 - CYLINDERS

Main features

8 ÷ 25 **AFM**
Bores Ø Type

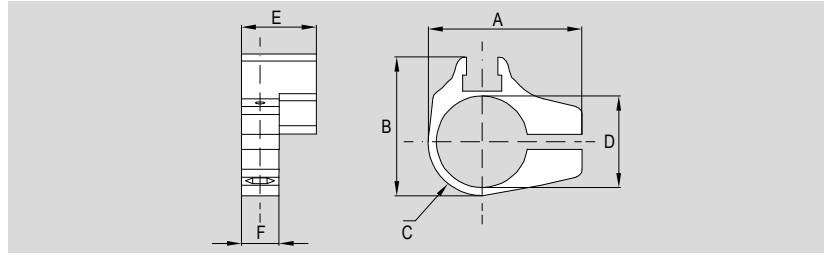

Technical data

Type	Description	Material
AFM..	Locking band for mounting magnetic reed switches type "T" on cylinders ISO 6432 in aluminium and Stainless Steel. Mounting screw included.	Polyamide, aluminium

Dimensions

For cylinder Ø mm	Code	Item	A	B	C	ØD	E	F
8	072901	AFM8	21,4	18,9	6,45	9,3	18	9
10	072902	AFM10	23,4	20,9	7,45	11,3	18	9
12	072903	AFM12	25,4	22,9	8,45	13,3	18	9
16	072904	AFM16	29,4	26,9	10,45	17,3	18	9
20	072905	AFM20	33,4	30,9	12,45	21,3	18	9
25	072906	AFM25	38,4	35,9	14,95	26,3	18	9

Main features

10 ÷ 63 **AFR**
Bores Ø Type

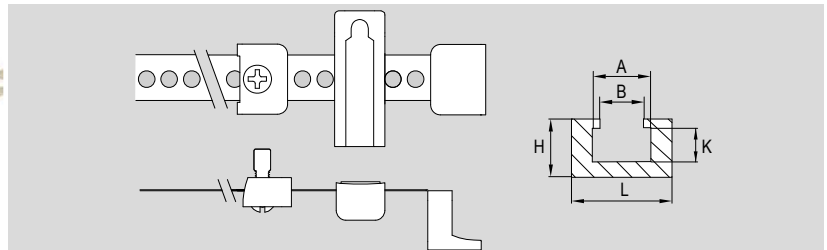

Technical data

Type	Description	Material
AFR..	Locking band for mounting magnetic reed switches type "T" on round cylinders in aluminium or Stainless Steel and on Stainless Steel compact cylinders ISO 21287. Universal metal band, screw and adapter included in kit.	Polyamide, aluminium

Dimensions

For cylinder Ø mm	Code	Item	A	B	H	K	L	Weight (g)
10 ÷ 63	072907	AFR1063	6,5	5,6	8	3,3	10	-

Magnetic Reed Switches and Brackets

Brackets for magnetic reed switches



Main features

12 ÷ 100 **AS108**

Bores Ø Type

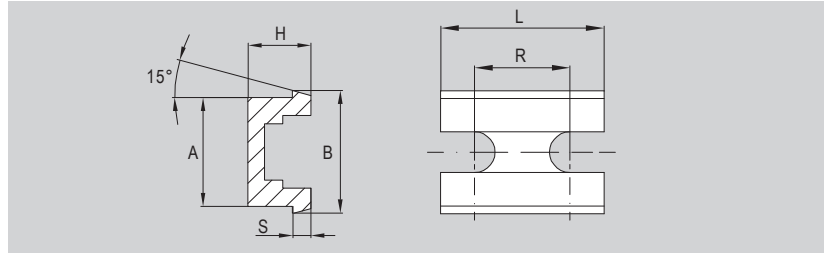

Technical data

Type	Description	Material
AS108	Bracket for mounting magnetic reed switches type "T" on short stroke cylinders.	Polyamide

Dimensions

For cylinder Ø mm	Code	Item	A	B	H	S	L	R
12 ÷ 100	072915	AS108	12	13,5	6,9	2	18	10,5

Main features

18 **AS109**

Bores Ø Type

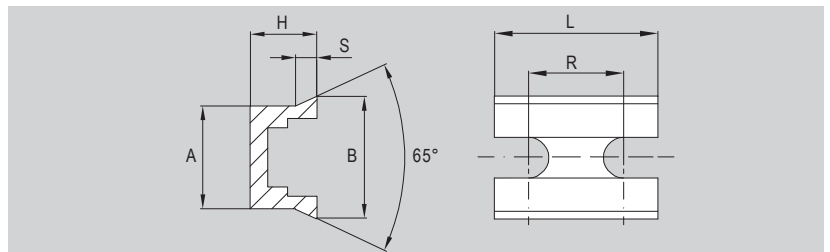

Technical data

Type	Description	Material
AS109	Bracket for mounting magnetic reed switches type "T" on rodless cylinders. In bores larger than Ø 18, the switches fit in grooves .	Polyamide

Dimensions

For cylinder Ø mm	Code	Item	A	B	H	S	L	R
18	072916	AS109	10,1	12,9	6,95	2,2	18	12,5

Magnetic Reed Switches and Brackets

Brackets for magnetic reed switches



Main features

25 ÷ 320

AS..

Bores Ø

Type

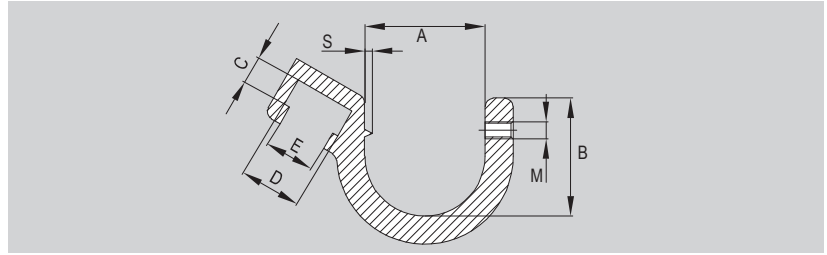

Technical data

Type	Description	Material
AS101 ÷ AS106; AS110	Bracket for mounting magnetic reed switches type "T" on cylinders ISO 15552 , cylinders CNOMO and short stroke cylinders with bores larger than Ø 100. Mounting screw included.	Aluminium

Dimensions

For cylinder type Ø mm					Code	Item	A	B	C	D	E	S	M
AMA BMA	AMT BMT CNOMO	CLSM CLDM	CRTH CRTHD CRTF	AMX									
32 ÷ 40	-	125	40	80 ÷ 100	072908	AS101	11,5	11	3,4	6,7	5,4	0,5	M4
50 ÷ 63	125	160	63	125	072909	AS102	14,5	14	3,4	6,7	5,4	0,5	M4
80 ÷ 100	160 ÷ 200	200	80	160 ÷ 200	072910	AS103	16,5	20	3,4	6,7	5,4	0,5	M4
125	-	250	-	-	072911	AS104	17,5	24	3,4	6,7	5,4	0,5	M4
-	25 ÷ 40	-	-	32 ÷ 40	072912	AS105	7	8	3,4	6,7	5,4	0,5	M4
-	50 ÷ 100	-	-	50 ÷ 63	072913	AS106	10	14	3,4	6,7	5,4	0,5	M4
-	250 ÷ 320	-	-	-	072917	AS110	24,5	21	3,4	6,7	5,4	0,5	M4

Magnetic Reed Switches and Brackets

Brackets for magnetic reed switches



Main features

32 ÷ 100

AS..

Bores Ø

Type

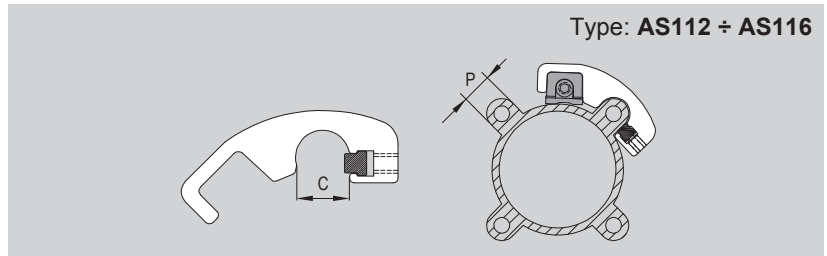

25 ÷ 200

AS..

Bores Ø

Type

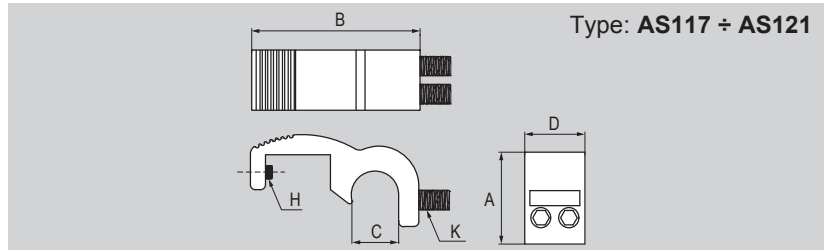

Technical data

Type	Description	Material
AS112 ÷ AS116	Bracket for mounting high temperatures magnetic reed switches on cylinders with profiled barrel.	Aluminium
AS117 ÷ AS121	Bracket for mounting high temperatures magnetic reed switches on cylinders with tube and tie-rods.	Aluminium

Dimensions

For cylinder type Ø mm			Code	Item	A	B	C	D	P	H	K
AMA BMA	AMT BMT CNOMO	AMX									
32 ÷ 40	-	-	077838	AS114	-	-	10,9	-	10,4	-	-
50 ÷ 63	-	-	077651	AS113	-	-	14,1	-	13,5	-	-
80	-	-	074055	AS112	-	-	15,45	-	15	-	-
100	-	-	077839	AS115	-	-	16,3	-	16	-	-
125	-	-	074007	AS116	-	-	19,8	-	18,7	-	-
-	25 ÷ 40	32 ÷ 40	074041	AS117	19,1	31,8	7,3	12	-	M2,6	M4x10
-	50 ÷ 63	50 ÷ 63	074043	AS118	18,4	33,7	9,3	12	-	M2,6	M4x10
-	80 ÷ 100	80 ÷ 100	074087	AS119	16,7	35,9	11,2	12	-	M2,6	M4x10
-	125	125	074155	AS120	24	38	13,5	12	-	M2,6	M4x10
-	160 ÷ 200	-	074169	AS121	24	40	15,5	12	-	M2,6	M4x10