

HOT WATER AND STEAM VALVES



Steam



Water

2/2

Actuation	Body	Function	Port Size	Orifice (mm)	Flow Factor Kv(l/min)	MOPD (bar)	Max Fluid Temp. (°C)	Page Parker Valves	Page Parker LUCIFER® Valves
Direct Operated	Brass/Pipe mounting	Normally Closed	1/8"	2.5	3.2	30	140	126	-
			1/4"	2.5 to 5	11	30	180	126	128
			3/8"	6	12	5	140	-	128
			1/2"	8.5 to 11	36	4	120	-	128
	303 Stainless St./Pipe mounting	Normally Closed	1/4"	1.5 to 5	10	100	180	-	130
Magnalift	Brass/Pipe mounting	Normally Closed	3/8"	15	65	10	140	-	132
			1/2"	15	65	10	140	-	132
			3/4"	15	80	10	140	-	132
			1"	15	80	10	140	-	132
Pilot Operated	Brass/Pipe mounting	Normally Closed	3/8"	10 to 16	78	16	180	134	-
			1/2"	10 to 16	78	16	180	134	138
			3/4"	18 to 27	193	14	180	136	-
			1"	18 to 27	193	14	180	136	-

2/2

HOT WATER AND STEAM VALVES DIRECT OPERATED



Commercial Equipment



Industrial Equipment



Medical / Instrumentation

BRASS PIPE MOUNTING

NORMALLY CLOSED

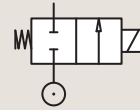

Port size	Orifice Ø	Flow factors			Operating Pressure Differential			Fluid Temp.		Seat Seal	Parker Valves			Power		Coil Group	Dwg. No.
		Kv	KV	Qn	Min	Max(MOPD)	Min	Max	Valve Order Number		Valve Type	Coil Type	AC W	DC W			
BSP	mm	l/min	m³/h	m³/h	bar	AC bar	DC bar	°C	°C								
1/8"	2.5	3.2	0.20	-	0	30	-	-30	140	Ruby	362496J	PM140IR	ZB09	9	-	20.1/20.2	027
	2.5	3.2	0.20	-	0	-	17	-30	140	Ruby	362496J	PM140IR	ZB12	-	12	20.1/20.2	027
	2.5	3.2	0.20	-	0	30	-	-30	140	Ruby	362518J ₁	PM140CR	ZB09	9	-	20.1/20.2	026
	2.5	3.2	0.20	-	0	-	17	-30	140	Ruby	362518J ₁	PM140CR	ZB12	-	12	20.1/20.2	026
	2.5	3.2	0.20	-	0	30	-	-30	140	Ruby	362518J ₁	PM140CR	ZH14	14	-	20.1/20.2	026
	2.5	3.2	0.20	-	0	-	17	-30	140	Ruby	362518J ₁	PM140CR	ZH16	-	16	20.1/20.2	026
1/4"	3	4.2	0.25	-	0	10	-	-10	140	EPDM	360470 ₂	PM126YH	ZB09	9	-	20.1/20.2	008
	3	4.2	0.25	-	0	-	6	-10	140	EPDM	360470 ₂	PM126YH	ZB12	-	12	20.1/20.2	008
	3	4.2	0.25	-	0	10	-	-10	140	EPDM	360470 ₂	PM126YH	ZH14	14	-	20.1/20.2	008
	3	4.2	0.25	-	0	-	6	-10	140	EPDM	360470 ₂	PM126YH	ZH16	-	16	20.1/20.2	008
	3	4.2	0.25	-	0	10	-	-10	180	PTFE	360475 ₂	PM126YT	ZH14	14	-	20.1/20.2	008
	3	4.2	0.25	-	0	-	10	-10	180	PTFE	360475 ₂	PM126YT	ZH16	-	16	20.1/20.2	008
	3	4	0.24	-	0	30	-	-30	140	Ruby	362524J	PM140DR	ZB09	9	-	20.1/20.2	026
	3	4	0.24	-	0	-	12	-30	140	Ruby	362524J	PM140DR	ZB12	-	12	20.1/20.2	026
	3	4	0.24	-	0	30	-	-30	140	Ruby	362524J	PM140DR	ZH14	14	-	20.1/20.2	026
	3	4	0.24	-	0	-	12	-30	140	Ruby	362524J	PM140DR	ZH16	-	16	20.1/20.2	026
	3	3.3	0.2	-	0	10	-	-10	140	EPDM	364880J ₂	PM158IH	ZH14	14	-	20.2	042
	3	3.3	0.2	-	0	-	4	-10	140	EPDM	364880J ₂	PM158IH	ZH16	-	16	20.2	042
	3	3.3	0.2	-	0	10	-	-10	180	PTFE	364884J ₂	PM158IT	ZH14	14	-	20.2	042
	3	3.3	0.2	-	0	-	10	-10	180	PTFE	364884J ₂	PM158IT	ZH16	-	16	20.2	042

Notes:

1. DIN-EN-ISO 23553-1 (2009-10) approved for oil burners
2. Maximum pressure for steam: 4 Bar (140°C)



For this page	Port size	Orifice (mm)	Kv (l/min)	MOPD (bar)	Fluid Temp (°C)	Amb Temp (°C)
From	1/8"	2.5	3.2	4	-30	-10
To	1/4"	3	4.2	30	180	50

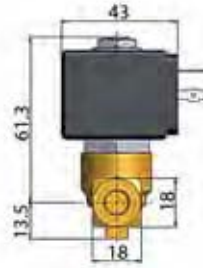
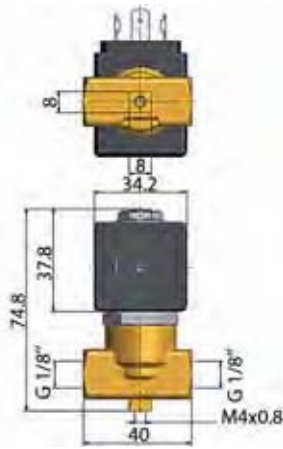

Drawing 027

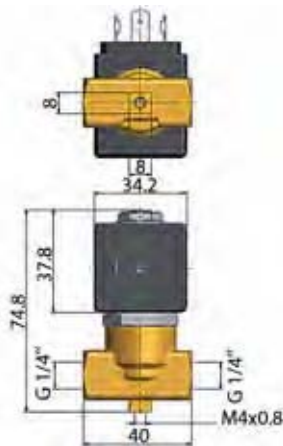

Drawing 026

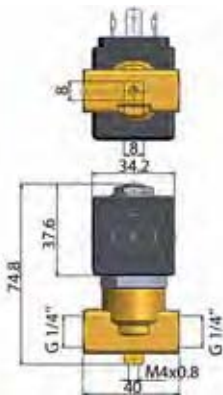

Drawing 008

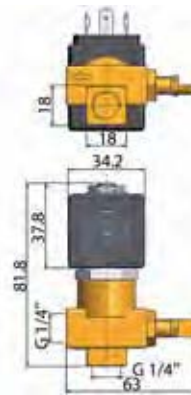

Drawing 042

2/2

HOT WATER AND STEAM VALVES

DIRECT OPERATED

BRASS

PIPE MOUNTING

NORMALLY CLOSED

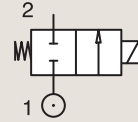

Port size	Orifice Ø	Flow factors			Operating Pressure Differential			Fluid Temp.		Seat Seal	Parker LUCIFER® Valves			Power		Coil Group	Dwg. No.
		Kv l/min	KV m³/h	Qn l/min	Min bar	Max(MOPD) AC bar	DC bar	Min °C	Max °C		Valve Ref.	Housing Ref.	Coil Ref.	AC W	DC W		
1/4"	3	4.5	0.27	-	0	10	7	0	100	EPDM	121K0323	2995	481865	8	9	2.0	3510
	3	4.5	0.27	-	0	10	8.5	0	120	EPDM	121K0323	4270	481000	8	8	2.0	3510
	3	4.5	0.27	-	0	10	10	0	120	EPDM	121K0323	4270	486265	14	14	2.0	3510
	3	4.5	0.27	-	0	10	10	0	120	EPDM	121K0323	2995	492425	14	14	2.0	3510
	5	11	0.66	750	0	7	2	0	100	EPDM	121K0103	2995	481865	8	9	2.0	3510
	5	11	0.66	750	0	7	2.8	0	120	EPDM	121K0103	4270	481000	8	8	2.0	3510
	5	11	0.66	750	0	7	5	0	120	EPDM	121K0103	4270	486265	14	14	2.0	3510
	5	11	0.66	750	0	4	3.5	0	120	EPDM	121K0103	2995	492425	14	14	2.0	3510
3/8"	5	11	0.66	750	0	7	2	0	100	EPDM	121K0113	2995	481865	8	9	2.0	3510
	6	12	0.72	1100	0	5	1.1	0	100	EPDM	121K3303	2995	481865	8	9	2.0	3551
	6	12	0.72	1100	0	5	1.5	0	120	EPDM	121K3303	4270	481000	8	8	2.0	3551
	6	12	0.72	1100	0	4	4	0	120	EPDM	121K3303	4270	486265	14	14	2.0	3551
1/2"	6	12	0.72	1100	0	4	4	0	140	EPDM	121K3303	2995	492425	14	14	2.0	3551
	8.5	25	1.5	-	0	2.2	0.5	0	120	EPDM	E121K4603	4270	481000	8	8	2.0	3427
	8.5	25	1.5	-	0	4	1.2	0	120	EPDM	E121K4603	4270	486265	14	14	2.0	3427
	8.5	25	1.5	-	0	4	1	0	120	EPDM	E121K4603	2995	492425	14	14	2.0	3427
	11	36	2.16	-	0	1.2	0.35	0	120	EPDM	E121K4503	4270	481000	8	8	2.0	3427
	11	36	2.16	-	0	2.5	0.7	0	120	EPDM	E121K4503	4270	486265	14	14	2.0	3427
11	36	2.16	-	0	2.5	0.5	0	120	EPDM	E121K4503	2995	492425	14	14	2.0	3427	



For this page	Port size	Orifice (mm)	Kv (l/min)	MOPD (bar)	Fluid Temp (°C)	Amb Temp (°C)
From	1/4"	3	4.5	0.4	0	-10
To	1/2"	11	36	10	140	50

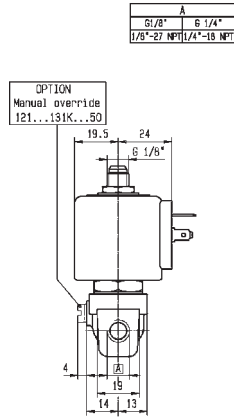
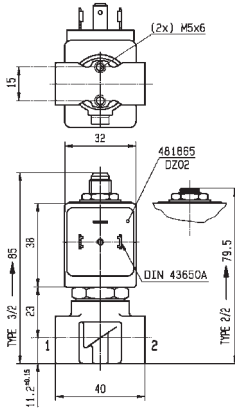

Drawing 3510

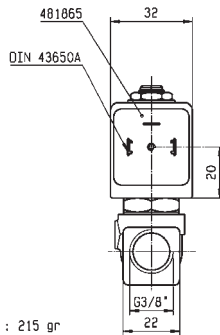
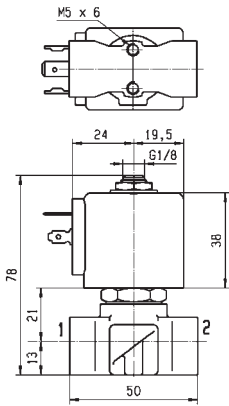

WEIGHT : 215 gr



Drawing 3551

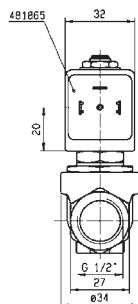
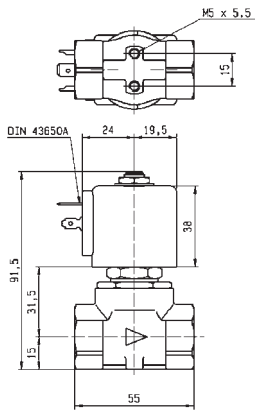

Drawing 3427

2/2

HOT WATER AND STEAM VALVES

DIRECT OPERATED

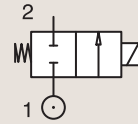
303 STAINLESS ST.
PIPE MOUNTING

NORMALLY CLOSED

Port size	Orifice Ø	Flow factors			Operating Pressure Differential			Fluid Temp.		Seat Seal	Parker LUCIFER® Valves			Power		Coil Group	Dwg. No.
		Kv l/min	KV m³/h	Qn l/min	Min bar	Max(MOPD) AC bar	DC bar	Min °C	Max °C		Valve Ref.	Housing Ref.	Coil Ref.	AC W	DC W		
1/4"	1.5	1.5	0.09	80	0	60	25	0	100	Ruby	121V5463	2995	481865	8	9	2.0	8116
	1.5	1.5	0.09	80	0	75	30	0	130	Ruby	121V5463	4270	481000	8	8	2.0	8116
	1.5	1.5	0.09	80	0	100	55	0	140	Ruby	121V5463	4270	486265	14	14	2.0	8116
	2.5	3.5	0.21	220	0	28	10	0	100	Ruby	121V5763	2995	481865	8	9	2.0	8116
	2.5	3.5	0.21	220	0	34	12	0	130	Ruby	121V5763	4270	481000	8	8	2.0	8116
	2.5	3.5	0.21	220	0	50	22	0	140	Ruby	121V5763	4270	486265	14	14	2.0	8116
	3	4.5	0.27	315	0	20	7	0	100	Ruby	121V5363	2995	481865	8	9	2.0	8116
	3	4.5	0.27	315	0	25	8.5	0	130	Ruby	121V5363	4270	481000	8	8	2.0	8116
	3	4.5	0.27	315	0	36	15	0	140	Ruby	121V5363	4270	486265	14	14	2.0	8116
	4	7	0.42	450	0	12	4	0	100	Ruby	121V5263	2995	481865	8	9	2.0	8116
	4	7	0.42	450	0	15	5	0	130	Ruby	121V5263	4270	481000	8	8	2.0	8116
	4	7	0.42	450	0	22	10	0	180	Ruby	121V5263	4270	486265	14	14	2.0	8116
	5	10	0.6	750	0	8.5	2	0	100	Ruby	121V5163	2995	481865	8	9	2.0	8116
	5	10	0.6	750	0	10	3.5	0	130	Ruby	121V5163	4270	481000	8	8	2.0	8116
5	10	0.6	750	0	14	6.5	0	140	Ruby	121V5163	4270	486265	14	14	2.0	8116	



For this page	Port size	Orifice (mm)	Kv (l/min)	MOPD (bar)	Fluid Temp (°C)	Amb Temp (°C)
From	1/4"	1.5	1.5	2	0	-10
To	1/4"	5	10	100	180	50

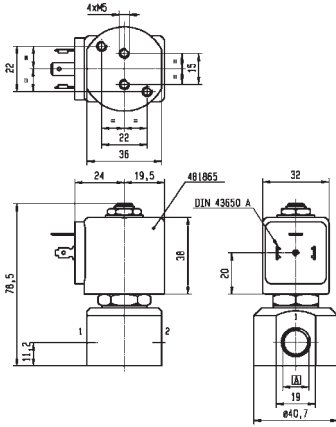

A	G 1/8"
	G 1/4"



Drawing 8116

2/2

HOT WATER AND STEAM VALVES
MAGNALIFT

Commercial Equipment



Industrial Equipment



Medical / Instrumentation

BRASS
PIPE MOUNTING

NORMALLY CLOSED

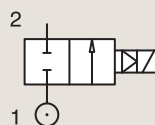

Port size	Orifice Ø	Flow factors			Operating Pressure Differential			Fluid Temp.		Seat Seal	Parker LUCIFER® Valves			Power		Coil Group	Dwg. No.
		Kv l/min	KV m³/h	Qn l/min	Min bar	Max(MOPD) AC bar	DC bar	Min °C	Max °C		Valve Ref.	Housing Ref.	Coil Ref.	AC W	DC W		
3/8"	15	65	3.9	-	0	10	-	0	100	EPDM	221G1303	2995	481865	8	-	2.0	3732
	15	65	3.9	-	0	10	-	0	120	EPDM	221G1303	4270	481000	8	-	2.0	3732
	15	65	3.9	-	0	4	4	0	140	EPDM	221G1303	4270	486265	14	14	2.0	3732
	15	65	3.9	4500	0	10	10	-10	100	FKM	221G1330 ₁	2995	481865	8	9	2.1	3732
	15	65	3.9	4500	0	10	10	-10	120	FKM	221G1330 ₁	-	492070	9	8	2.1	3732
	15	65	3.9	4500	0	10	10	-10	120	FKM	221G1330 ₁	-	492190	11	9	2.1	3732
1/2"	15	65	3.9	-	0	10	-	0	100	EPDM	221G1503	2995	481865	8	-	2.0	3732
	15	65	3.9	-	0	10	-	0	120	EPDM	221G1503	4270	481000	8	-	2.0	3732
	15	65	3.9	-	0	10	7	0	140	EPDM	221G1503	4270	486265	14	14	2.0	3732
3/4"	15	80	4.8	-	0	10	-	0	100	EPDM	221G1603	2995	481865	8	-	2.0	3444
	15	80	4.8	-	0	10	-	0	120	EPDM	221G1603	4270	481000	8	-	2.0	3444
	15	80	4.8	-	0	4	4	0	140	EPDM	221G1603	4270	486265	14	14	2.0	3444
1"	15	80	4.8	-	0	10	-	0	100	EPDM	221G1703	2995	481865	8	-	2.0	3445
	15	80	4.8	-	0	10	-	0	120	EPDM	221G1703	4270	481000	8	-	2.0	3445
	15	80	4.8	-	0	10	10	0	140	EPDM	221G1703	4270	486265	14	14	2.0	3445

Notes:

1. Valves with model number ending in 30 or 31 are only compatible with explosion proof electrical parts shown, or with group 2.1 coils only in DC voltage.



For this page	Port size	Orifice (mm)	Kv (l/min)	MOPD (bar)	Fluid Temp (°C)	Amb Temp (°C)
From	3/8"	15	65	4	-10	-10
To	1"	15	80	10	140	50

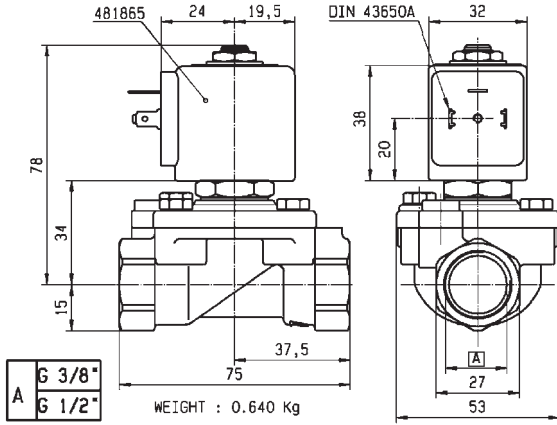

Drawing 3732

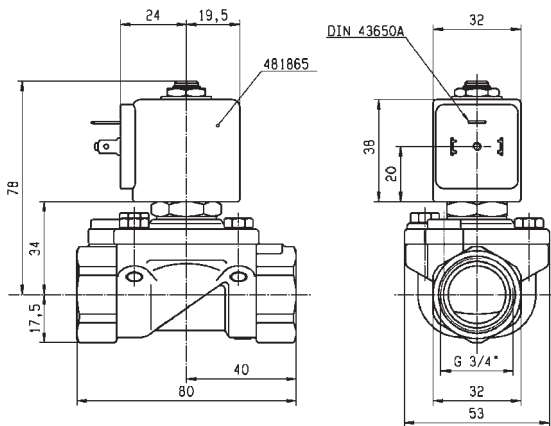

Drawing 3444

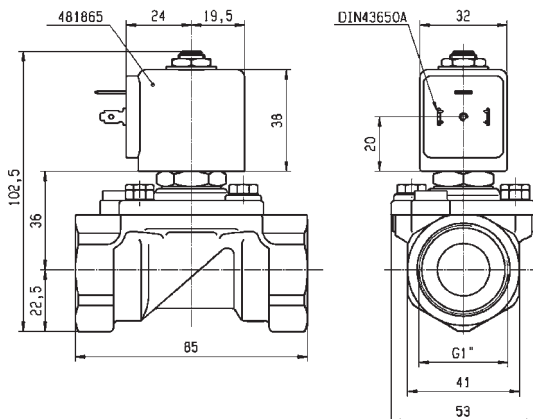

Drawing 3445

2/2

HOT WATER AND STEAM VALVES PILOT OPERATED



Commercial Equipment



Industrial Equipment



Medical / Instrumentation

BRASS PIPE MOUNTING

NORMALLY CLOSED

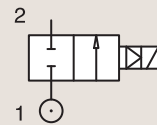

Port size	Orifice Ø	Flow factors			Operating Pressure Differential			Fluid Temp.		Seat Seal	Parker Valves			Power		Coil Group	Dwg. No.
		Kv l/min	KV m³/h	Qn m³/h	Min bar	Max(MOPD) AC bar	DC bar	Min °C	Max °C		Valve Order Number	Valve Type	Coil Type	AC W	DC W		
3/8"	10	22	1.32	-	0.5	16	-	-30	160	PTFE	364520 ¹	PM156.2IR	ZB09	9	-	20.1	041
	16	78	4.7	-	0.5	10	-	-30	180	PTFE	362262	PM135IT	ZH14	14	-	20.2	017
	16	78	4.7	-	0.5	-	10	-30	180	PTFE	362262	PM135IT	ZH16	-	16	20.2	017
1/2"	16	78	4.7	-	0.5	10	-	-30	180	PTFE	362263	PM135AT	ZH14	14	-	20.2	016
	16	78	4.7	-	0.5	-	10	-30	180	PTFE	362263	PM135AT	ZH16	-	16	20.2	016

Notes:

1. Maximum pressure for steam: 6.5 Bar (160°C)



For this page	Port size	Orifice (mm)	Kv (l/min)	MOPD (bar)	Fluid Temp (°C)	Amb Temp (°C)
From	3/8"	10	22	10	-30	-10
To	1/2"	16	78	16	180	50

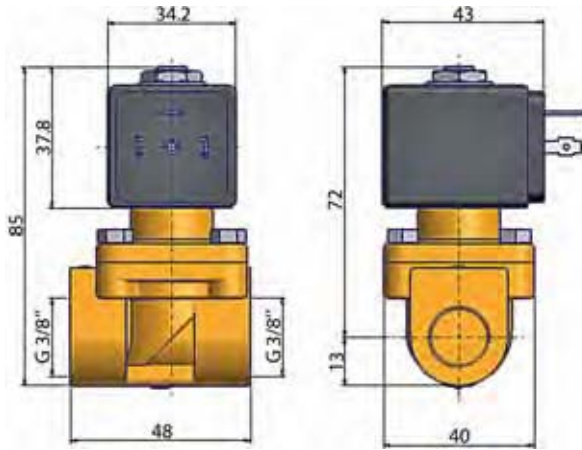

Drawing 041

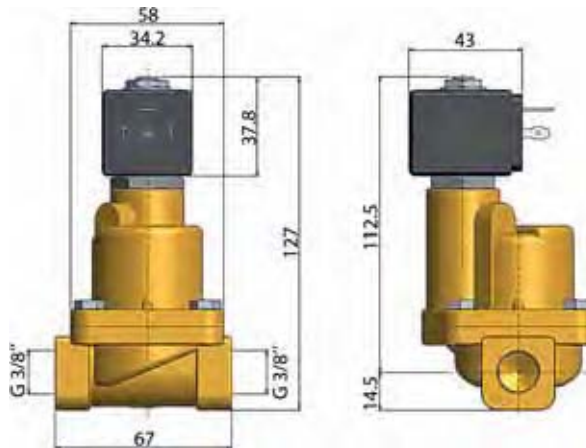

Drawing 017

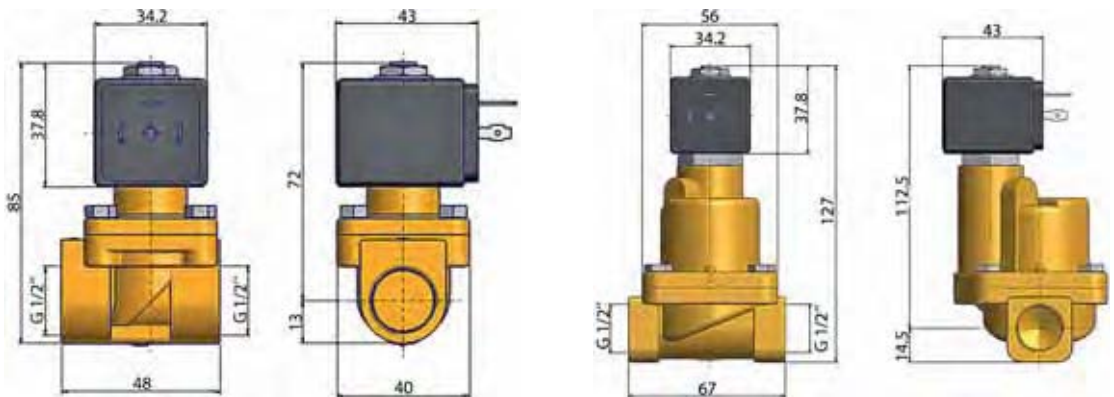

Drawing 038

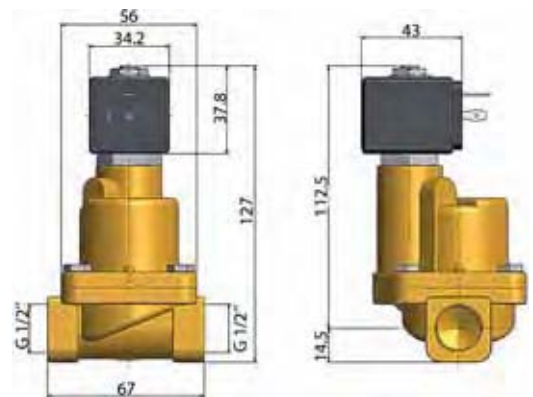

Drawing 016

2/2

HOT WATER AND STEAM VALVES
PILOT OPERATED

BRASS

PIPE MOUNTING

NORMALLY CLOSED

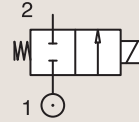

Port size	Orifice Ø	Flow factors			Operating Pressure Differential			Fluid Temp.		Seat Seal	Parker Valves			Power		Coil Group	Dwg. No.
		Kv l/min	KV m³/h	Qn m³/h	Min bar	Max(MOPD) AC bar	DC bar	Min °C	Max °C		Valve Order Number	Valve Type	Coil Type	AC W	DC W		
3/4"	18	37	2.22	-	0.5	14	-	-30	160	PTFE	364530 ₁	PM156.2CR	ZB09	9	-	20.1	039
	27	193	11.6	-	0.5	10	-	-30	180	PTFE	362264	PM135CT	ZH14	14	-	20.2	018
	27	193	11.6	-	0.5	-	10	-30	180	PTFE	362264	PM135CT	ZH16	-	16	20.2	018
1"	18	42	2.52	-	0.5	14	-	-30	160	PTFE	364535 ₁	PM156.2DR	ZB09	9	-	20.1	040
	27	193	11.6	-	0.5	10	-	-30	180	PTFE	362265	PM135DT	ZH14	14	-	20.2	019
	27	193	11.6	-	0.5	-	10	-30	180	PTFE	362265	PM135DT	ZH16	-	16	20.2	019

Notes:

1. Maximum pressure for steam: 6.5 Bar (160°C)



For this page	Port size	Orifice (mm)	Kv (l/min)	MOPD (bar)	Fluid Temp (°C)	Amb Temp (°C)
From	3/4"	18	37	10	-30	-10
To	1"	27	193	14	180	50

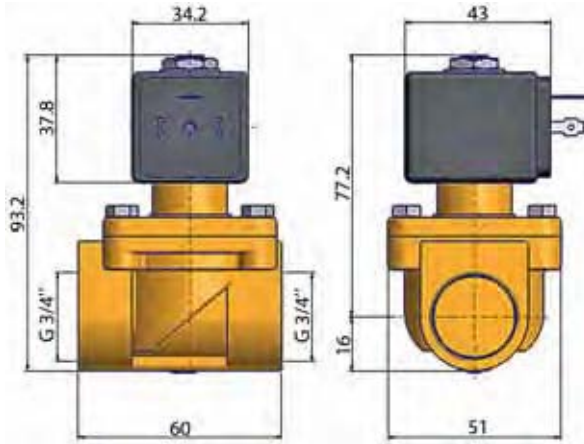

Drawing 039

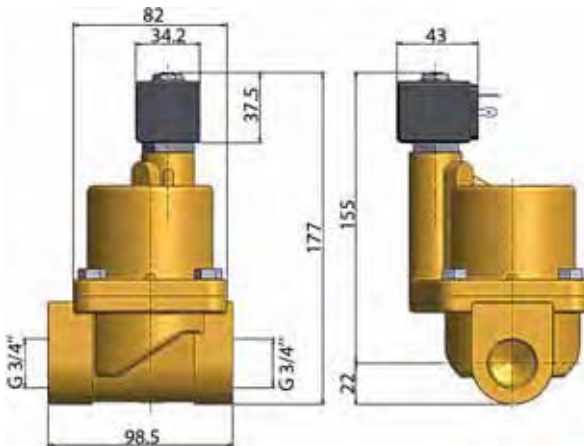

Drawing 018

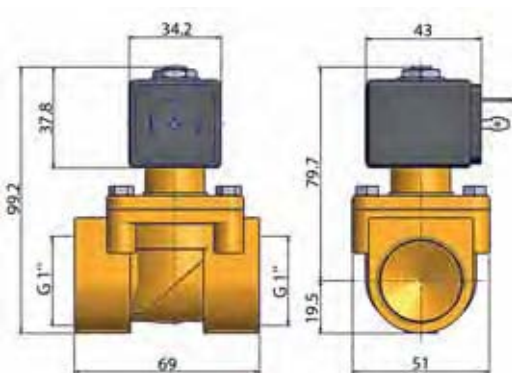

Drawing 040

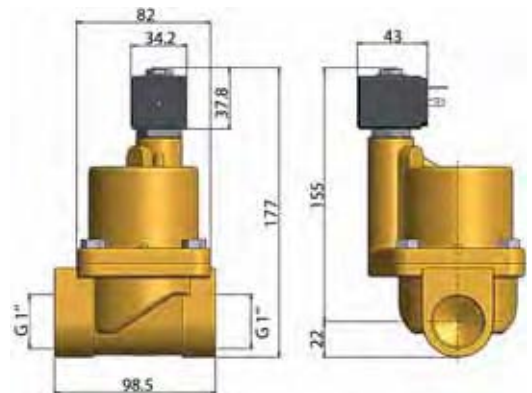

Drawing 019

2/2

HOT WATER AND STEAM VALVES PILOT OPERATED

BRASS

PIPE MOUNTING

NORMALLY CLOSED

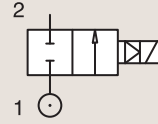

Port size	Orifice Ø	Flow factors			Operating Pressure Differential			Fluid Temp.		Seat Seal	Parker LUCIFER® Valves			Power		Coil Group	Dwg. No.
		Kv l/min	KV m³/h	Qn l/min	Min bar	Max(MOPD) AC bar	DC bar	Min °C	Max °C		Valve Ref.	Housing Ref.	Coil Ref.	AC W	DC W		
BSP	mm																
1/2"	11	36	2.16	-	0.2	10	4	0	120	EPDM	E321K1503	4270	481000	8	8	2.0	3427
	11	36	2.16	-	0.2	10	-	0	100	EPDM	E321K1503	4270	483520	9	-	2.0	3427
	11	36	2.16	-	0.2	10	-	0	120	EPDM	E321K1503	4270	486992	10	-	2.0	3427



For this page	Port size	Orifice (mm)	Kv (l/min)	MOPD (bar)	Fluid Temp (°C)	Amb Temp (°C)
From	1/2"	11	36	4	0	-10
To	1/2"	11	36	10	120	50

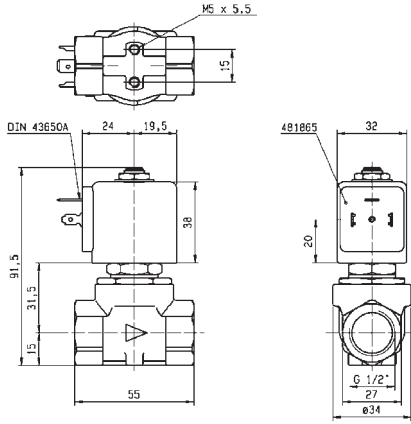

Drawing 3427

2 WAY VALVES

